

- Dual channel
- AC 120 V supply voltage
- Selectable mode of operation
- Optional lead breakage monitoring (LB)
- 1 Signal output with 1 Form 'C' relay per channel
- Hazardous area field circuit EEx ia IIC and Class I, Div 1, Groups A-G

**Use standard model  
KFA5-SR2-Ex2.W with new  
systems**

This device is a dual channel, galvanically isolated intrinsic safety barrier that transfers discrete signals (NAMUR sensors/mechanical contacts) from a hazardous area to a safe area. The proximity sensor or switch controls a Form 'C' relay contact for the safe area load. The barrier output changes state when the input signal does. The output state can be reversed by the position of an external jumper. See the Mode of Operation Chart on page 184 for details.

Lead breakage (LB) monitoring can be selected by placing an external resistor across the mechanical contact and positioning the external jumper in the proper location. NAMUR proximity sensors, however, are designed with the LB function making external resistors unnecessary. If a LB fault occurs, the output relay reverts to the de-energized state.

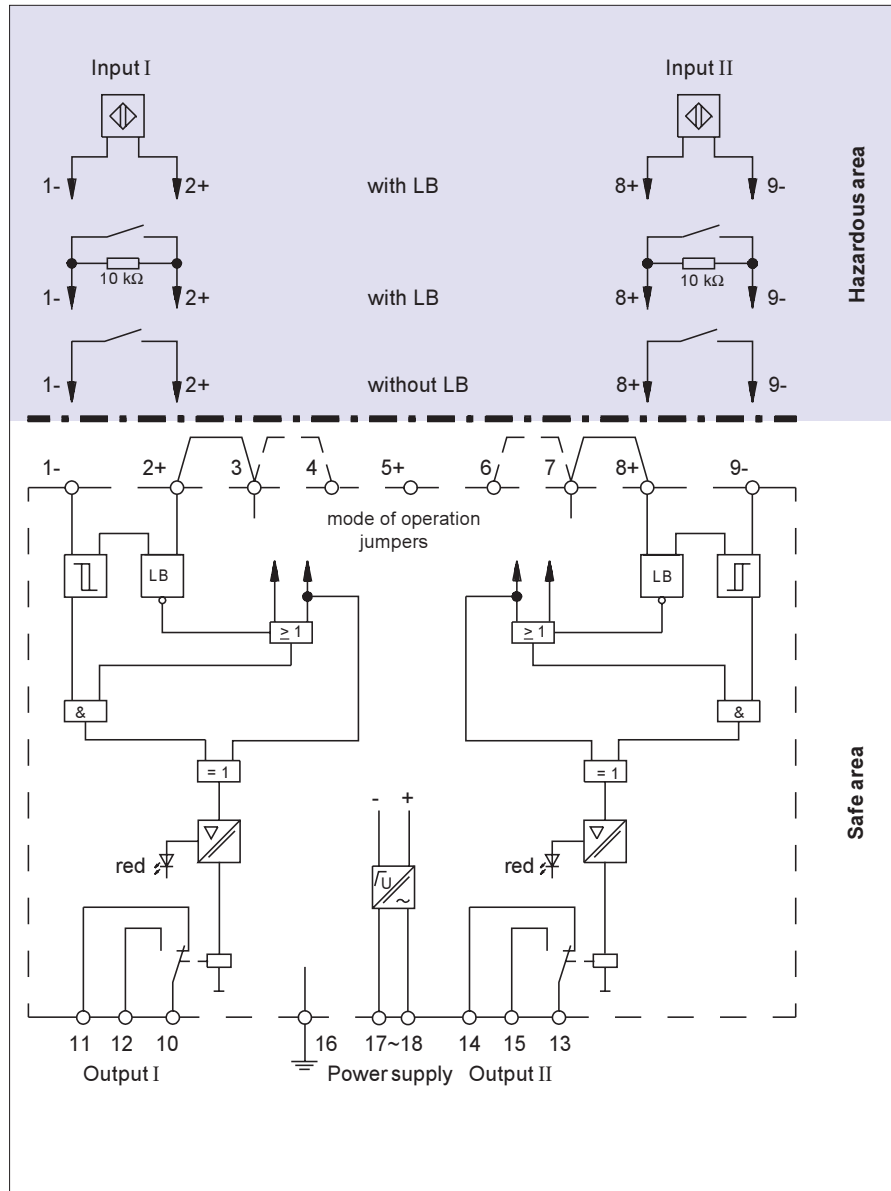

**Front View**

Housing type W2  
see page 428

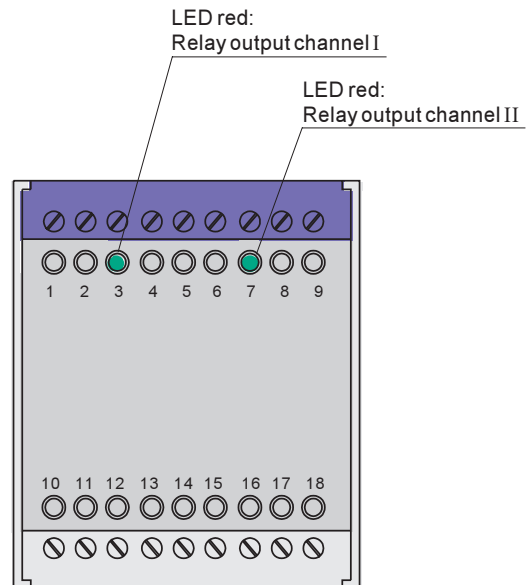



<b>Technical data</b> <b>Power supply</b> Nominal voltage Power consumption	AC 102 V ... 126 V, 45 Hz ... 60 Hz ≈ 3.5 VA	Terminals 17, 18
<b>Input (Intrinsically safe)</b> Nominal data Input pulse length / Input pulse interval Lead breakage (LB) monitoring	per DIN 19 234 or NAMUR, ≈ DC 8 V / ≈ 8 mA ≥ 0.5 ms / ≥ 0.5 ms Breakage J ≤ 0.1 mA	Terminals 1-, 2+; 8+, 9-
<b>Certificate of Conformity Peak Values</b> $U_0 / I_0 / P_0$ <b>Allowable circuit values</b> <b>Ignition protection method, category</b> Explosion group Max. external capacitance Max. external inductance	<b>PTB Nr. Ex-79/2043X</b> DC 13.5 V / 62 mA / 125 mW	for additional international approvals see page 430
<b>Output (Not intrinsically safe)</b> <b>Output:</b> Contact load Mechanical life Energizing delay / De-energizing delay	AC: 250 V / 4 A / 500 VA / $\cos \varphi = 0.7$ ; DC: 220 V / 0.1 A; 60 V / 0.6 A; 24 V / 4 A 10 <sup>7</sup> operations ≈ 10 ms / ≈ 20 ms	Terminals 10, 11, 12; 13, 14, 15
<b>Transfer characteristics</b> Switching frequency	< 10 Hz	
<b>Certificate</b> PTB (Germany) GL (Germany) ASEV (Switzerland) BASEEFA (GB) LCIE (France) FM (USA) CSA (Canada) SAA (Australia)	Nr. Ex.-79/2043X 94945 HH 9/80 Nr. 90.102719X No. Ex 80244X N° 79.2074X J.I.OFOA6.AX (3610) LR 36087-4 No. Ex 607	
<b>Weight</b> <b>Ambient temperature</b>	≈ 410 g (≈ 14.5 oz) -25 °C ... +60 °C (-13 °F ... 140 °F)	
<b>Mode of Operation</b>  (jumper location)	A-mode(standard): Output energizes with input resistance low (jumper on Terminals 2,3 and 7,8)  R-mode: Output energizes with input resistance high (jumper on Terminals 3,4 and 7,8)  RS-mode: R-mode with lead breakage(LB) monitoring of the input (no jumpers)	