

CTM 10-MAG - Magazine

2838610

<https://www.phoenixcontact.com/fr/produits/2838610>



Please be informed that the data shown in this PDF document is generated from our online catalog. Please find the complete data in the user documentation. Our general terms of use for downloads are valid.



Magazine with a grounding rail to accommodate up to 10 LSA-PLUS protective plugs (COMTRAB CTM), to insert in CT-TERMIBLOCK or LSA-PLUS disconnect strip

Your advantages

- Space-saving due to compact design
- Flexible fields of application with modular protective plug
- Can be used in LSA-PLUS disconnect and control strips or CT-TERMIBLOCK via adapted connection technology

Commercial data

Item number	2838610
Packing unit	5 pc
Minimum order quantity	5 pc
Sales key	CL321Z
Product key	CL321Z
Catalog page	Page 193 (C-4-2019)
GTIN	4017918819620
Weight per piece (including packing)	23.79 g
Weight per piece (excluding packing)	23.59 g
Customs tariff number	85363010
Country of origin	DE

Technical data

Product properties

Product type	Magazine
Product family	COMTRAB
Type	LSA-PLUS module
Surge protection fault message	none

Connection data

Connection method	can be plugged into COMTRAB-TERMIBLOCK and LSA-PLUS disconnect and switching strips
-------------------	---

Dimensions

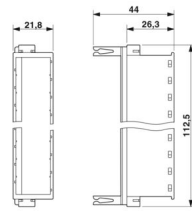
Dimensional drawing	
Width	112.5 mm
Height	21.8 mm
Depth	44 mm

Material specifications

Color	black (RAL 9005)
	Copper
Flammability rating according to UL 94	V-0
Housing material	PA

Mechanical properties

Mechanical data

Open side panel	No
-----------------	----

Protective circuit

Surge protection fault message	none
--------------------------------	------

Environmental and real-life conditions

Ambient conditions

Degree of protection	IP20
Ambient temperature (operation)	-25 °C ... 75 °C

Mounting

Mounting type	On CT-TERMIBLOCK and LSA-PLUS disconnect strip
---------------	--

CTM 10-MAG - Magazine

2838610

<https://www.phoenixcontact.com/fr/produits/2838610>



Drawings

Dimensional drawing

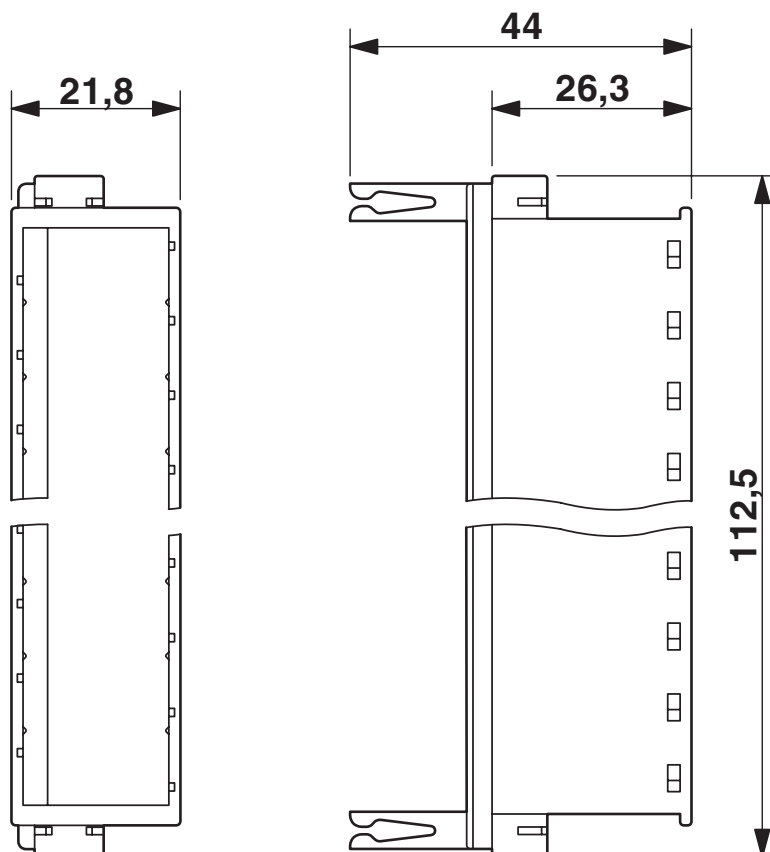

2838610

<https://www.phoenixcontact.com/fr/produits/2838610>

Approvals

 To download certificates, visit the product detail page: <https://www.phoenixcontact.com/fr/produits/2838610>



EAC

Approval ID: EAC-Zulassung



EAC

Approval ID: RU C-DE.*09.B.00169



UL Listed

Approval ID: FILE E 138168

Classifications

ECLASS

ECLASS-11.0	27130815
ECLASS-13.0	27171503

ETIM

ETIM 9.0	EC001466
----------	----------

UNSPSC

UNSPSC 21.0	39121600
-------------	----------

Environmental product compliance

EU RoHS

Fulfills EU RoHS substance requirements	Yes, No exemptions
---	--------------------

China RoHS

Environment friendly use period (EFUP)	EFUP-E
	No hazardous substances above the limits

EU REACH SVHC

REACH candidate substance (CAS No.)	No substance above 0.1 wt%
-------------------------------------	----------------------------

Phoenix Contact 2024 © - all rights reserved
<https://www.phoenixcontact.com>

PHOENIX CONTACT SAS
52 Boulevard de Beaubourg Emerainville
77436 Marne La Vallée Cedex 2 France
+33 (0) 1 60 17 98 98
documentation@phoenixcontact.fr