

## RB 2 Roller Track

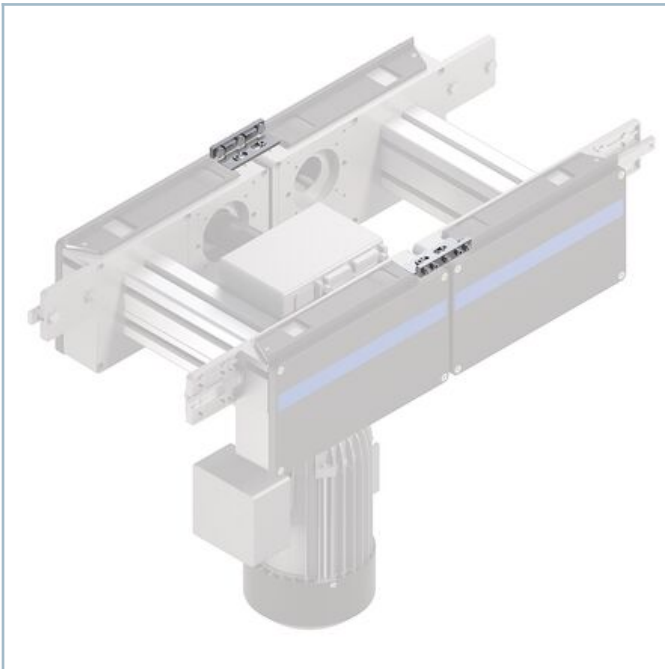

- It is used to support the workpiece pallets at the transition point between a conveyor unit and another adjacent conveyor unit. Necessary for workpiece pallets with  $l_{WT} < 320$  mm workpiece pallets
- Universal design

[PDF](#) Assembly instructions

# Technical data

No.		3842532822
ESD		yes
Material entry		Roller carrier: Aluminum Rollers: Steel, hardened

## Dimensions

### Roller track RB 2 / roller track set RB 2/UM 2

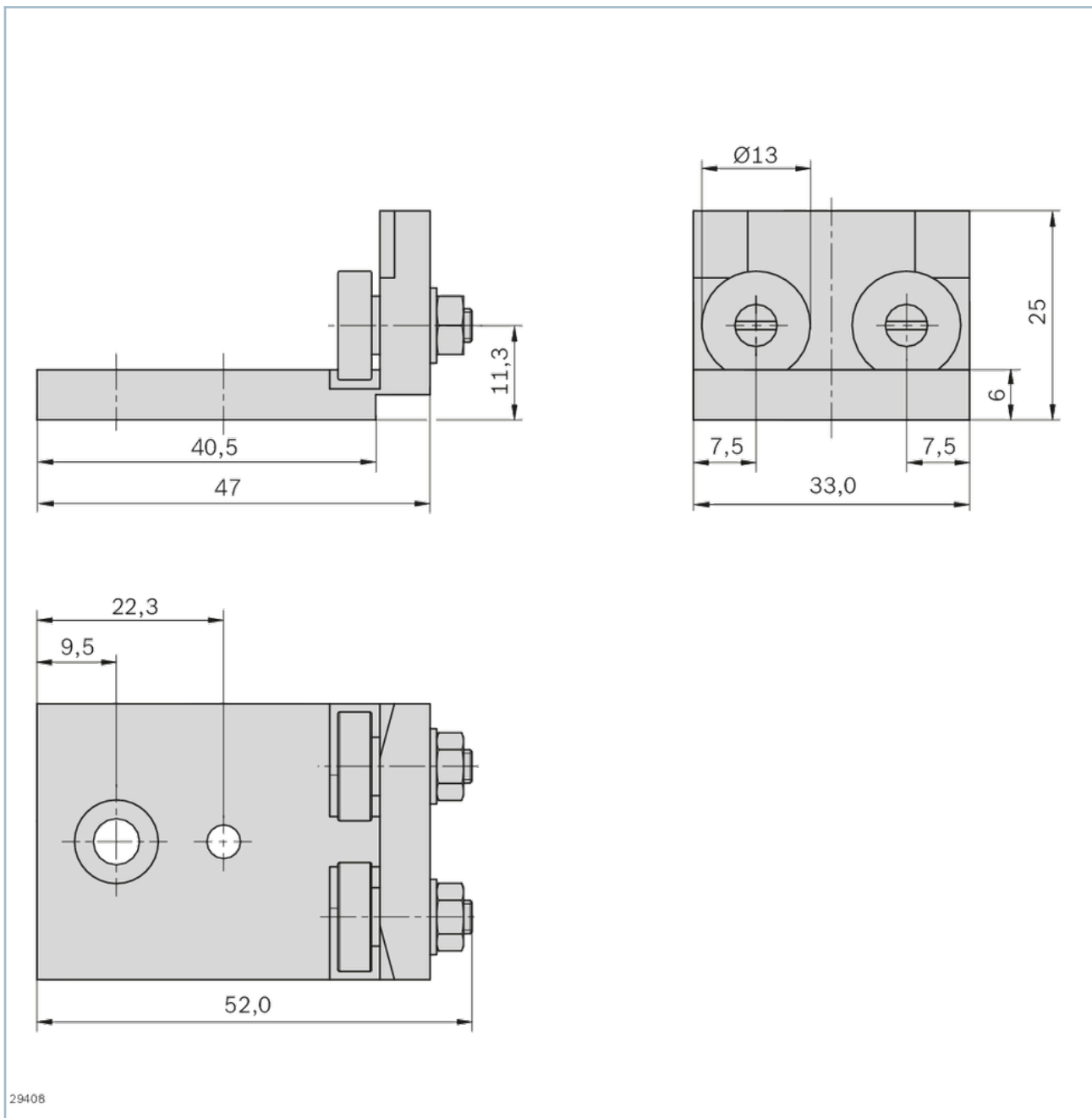

## Ordering codes

		No.
RB 2 Roller Track	2	3842532822