



VE 2/RS Return Stop



- Spring-loaded safety catch
- Can be used on the left or right

- Use for one direction of transport, reversible operation not permitted

Product description

The return stop prevents the workpiece pallet rebounding off the stop gate. The use of the VE 2/RS return stop is especially recommended when using an accumulation roller chain as the conveyor medium in conjunction with undamped stop gates. In normal condition, the stop gate is moved into the lock position by a spring and the workpiece pallet runs over the VE 2/RS in the direction of transport and is stopped against the direction of transport. Mounted inside the tracks, directly on the conveyor section.

Technical data

No.			3842531696
Max. total weight of workpiece pallet	m_G	kg	250
Mass	m	kg	3
Operating temperature ¹⁾	T	°C	0 ... +60
Material specification			Housing: PA 6 Lug cam: PA 66

1) High-temperature stop gate on request

Dimensions

VE 2/RS Return Stop

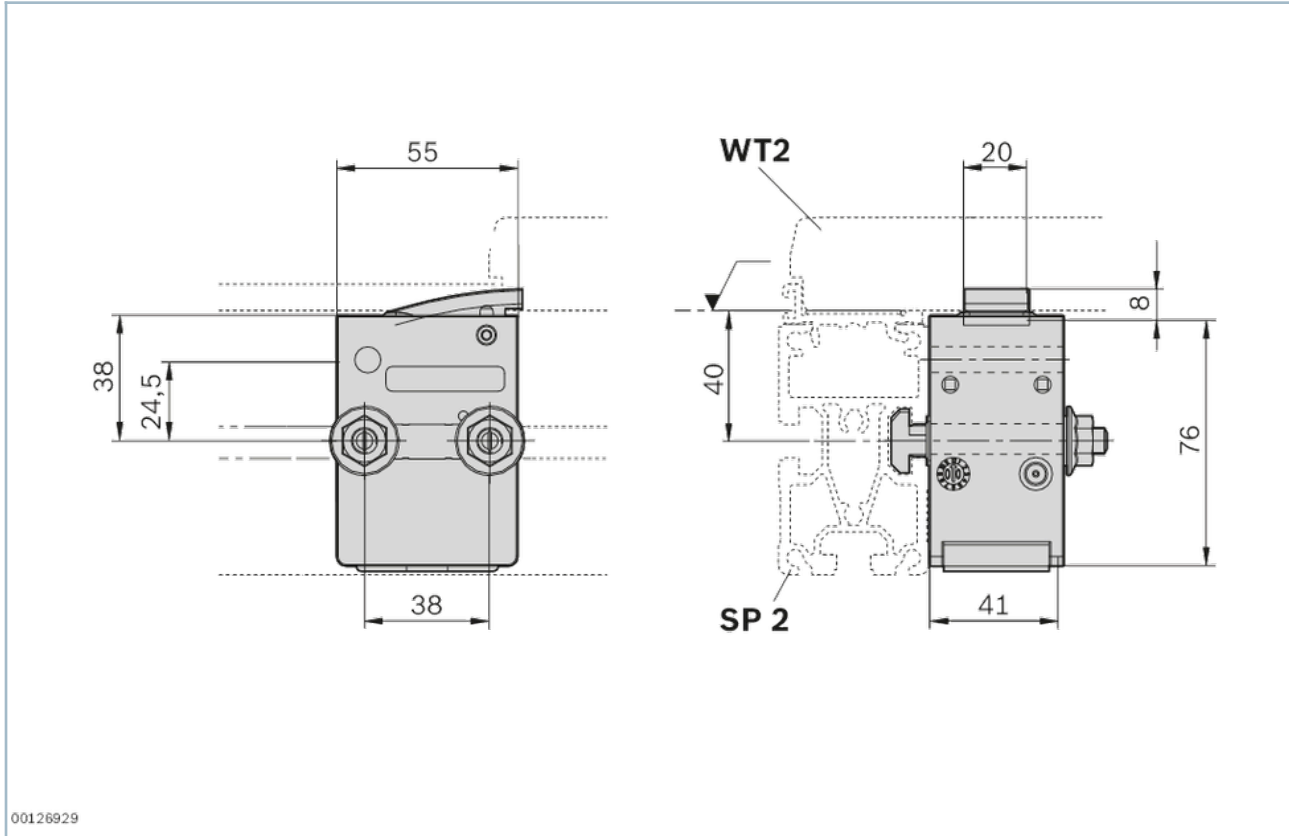

00126929

Information

Note: The VE 2/RS return stop can only be installed outside the workpiece pallet surface when using the WT 2/H and WT 2/F-H.

Delivery notes

Condition of Delivery

Fully assembled

Scope of delivery

Incl. all fastening material to mount on ST 2/... conveyor section

Ordering codes

	No.
VE 2/RS Return Stop	3842531696