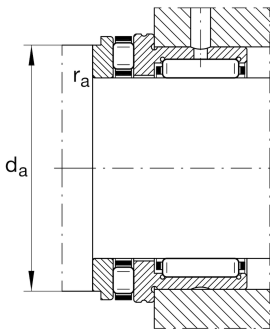
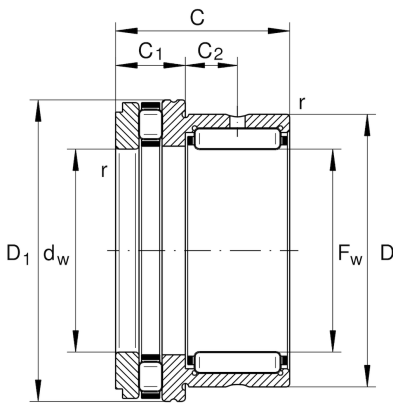
**NKXR20-XL**

Needle roller/axial cylindrical roller bearing

Needle roller/axial cylindrical roller bearings NKXR, axial component, single direction, to DIN 5429, without end cap, for oil lubrication

X-life

Technical information

**Main Dimensions & Performance Data**

F_w	20 mm	Bore diameter
D	30 mm	Outside diameter
C	30 mm	Height
C_r	18.600 N	Basic dynamic load rating, radial
C_{0r}	23.800 N	Basic static load rating, radial
C_a	25.000 N	Basic dynamic load rating, axial
C_{0a}	53.000 N	Basic static load rating, axial
C_{ur}	4.200 N	Fatigue load limit, radial
C_{ua}	7.500 N	Fatigue load limit, axial
n_G	10.000 1/min	Limiting speed
n_{gr}	4.200 1/min	Reference speed
$\approx m$	79,39 g	Weight

Mounting dimensions

d_a	30,7 mm	Mounting dimension shaft shoulder
$r_{a \max}$	0,3 mm	Maximum recess radius

Dimensions

$D_{1 \max}$	35,1 mm	Maximum outside diameter flange
C_1	10 mm	Width of the axial bearing component
C_2	10,5 mm	Distance to lubrication hole
d_w	20 mm	Bore diameter of shaft washer
r_{\min}	0,3 mm	Minimum chamfer dimension

Temperature range

T_{\min}	-30 °C	Operating temperature min.
T_{\max}	120 °C	Operating temperature max.



[View product details on medias](#)

11.04.2024, 13:44:07 CEST

SCHAEFFLER

Additional information

IR17X20X20-XL

Suitable inner rings IR