



### Main

Range of product	Modicon STB distributed I/O solution
Product or component type	Basic digital input module
Discrete input number	16
Discrete input voltage	24 V
Discrete input voltage type	DC

### Complementary

Input voltage limits	-3...5 V at state 0 11...30 V at state 1
Permissible voltage	30 V
Discrete input current	4.5 mA
Input current limits	<= 1.5 mA at state 0 >= 2 mA at state 1
Discrete input logic	Positive
Response time	2 ms on-to-off 2 ms off-to-on
Protection type	Power protection integrated fuse on PDM time lag 5 A Input protection resistor-limited Reverse polarity protection
Insulation between channels and logic bus	1500 V for 1 minute
Cold swapping	Yes
Hot swapping	Yes for basic NIMs
Product compatibility	I/O base STBXBA3000 Power distribution module STBPDT3100/3105
[Us] rated supply voltage	24 V DC
Supply	Power distribution module
Current consumption	100 mA 5 V DC logic bus
Marking	CE
Overvoltage category	II
Status LED	1 LED per channel green channel status (IN1 to IN16) 1 LED green module status (RDY)
Depth	65.1 mm
Height	18.4 mm
Width	125 mm
Product weight	0.086 kg

### Environment

Standards	EN/IEC 61131-2 type 3
Product certifications	CSA FM Class 1 Division 2 UL
Pollution degree	2 IEC 60664-1
Operating altitude	<= 2000 m
IP degree of protection	IP20 EN 61131-2 class 1

Ambient air temperature for operation	-25...70 °C without derating
Ambient air temperature for operation	32...140 °F without
Ambient air temperature for storage	-40...85 °C without
Ambient air temperature for storage	-40...185 °F without
Relative humidity	95 % 60 °C without condensation
Vibration resistance	5 gn 58...150 Hz 35 x 15 mm symmetrical DIN rail 3 gn 58...150 Hz 35 x 7.5 mm symmetrical DIN rail +/-0.35 mm 10...58 Hz
Shock resistance	30 gn 11 ms IEC 88 reference 2-27

Dimensions

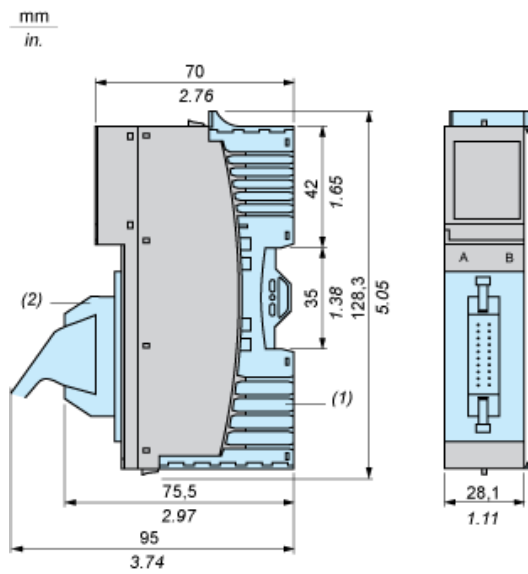

- (1) STBXBA3000 base (to be ordered separately)
- (2) STBXTS5510/5610/6510/6610 connector (to be ordered separately)

Wiring Diagrams

Examples

16 two-wire sensors

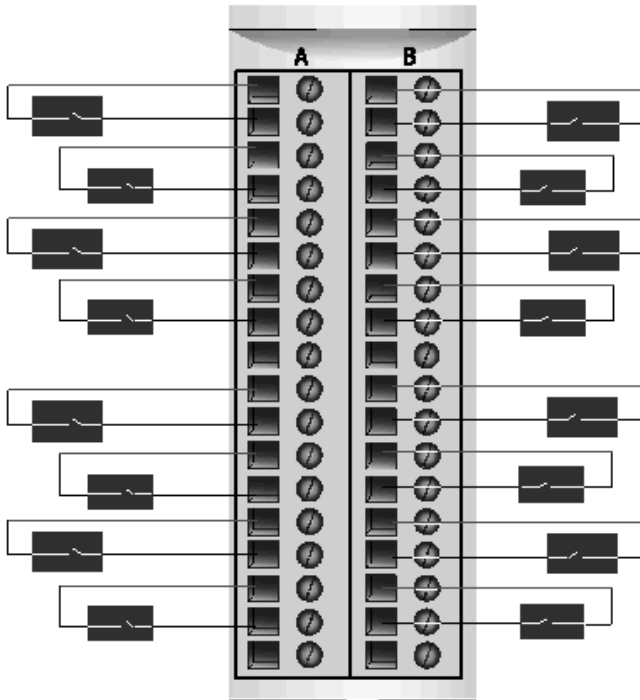

1 three-wire sensor per input group

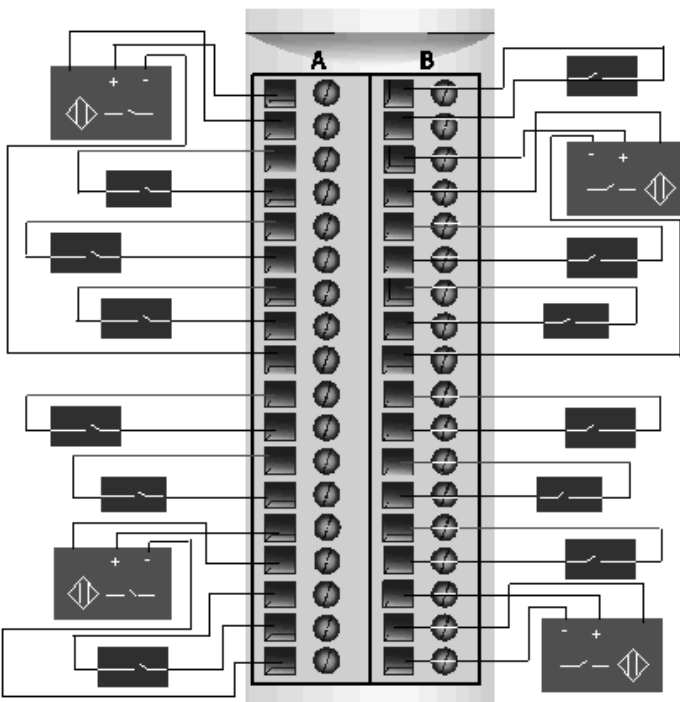

Pin	Left Connector	Right Connector
1	Sensor power group 1 (+)	Sensor power group 3 (+)
2	Input from Sensor 1	Input from Sensor 9

Pin	Left Connector	Right Connector
3	Sensor power group 1 (+)	Sensor power group 3 (+)
4	Input from Sensor 2	Input from Sensor 10
5	Sensor power group 1 (+)	Sensor power group 3 (+)
6	Input from Sensor 3	Input from Sensor 11
7	Sensor power group 1 (+)	Sensor power group 3 (+)
8	Input from Sensor 4	Input from Sensor 12
9	Sensor power (-) for a 3-wire sensor (PDM-)	Sensor power (-) for a 3-wire sensor (PDM-)
10	Sensor power group 2 (+)	Sensor power group 4 (+)
11	Input from Sensor 5	Input from Sensor 13
12	Sensor power group 2 (+)	Sensor power group 4 (+)
13	Input from Sensor 6	Input from Sensor 14
14	Sensor power group 2 (+)	Sensor power group 4 (+)
15	Input from Sensor 7	Input from Sensor 15
16	Sensor power group 2 (+)	Sensor power group 4 (+)
17	Input from Sensor 8	Input from Sensor 16
18	Sensor power (-) for a 3-wire sensor (PDM-)	Sensor power (-) for a 3-wire sensor (PDM-)