



SLC 500™ RTD/Resistance Input Module

(Catalog Number 1746-NR4)

Inside.....	page
Hazardous Location Considerations	2
Environnements dangereux	2
Overview	3
Required Tools and Equipment	4
Electrostatic Damage.....	5
NR4 Power Requirements.....	5
Modular Chassis Considerations.....	5
Fixed Expansion Chassis Considerations.....	6
General Considerations	6
Module Installation and Removal.....	7
Terminal Block Wiring and Removal	8
Wiring Considerations	9
Wiring Resistance Devices (Potentiometers) to the NR4 Module	12
Wiring Input Devices to the NR4 Module	14
Module Addressing.....	15
Channel Configuration	16
Specifications	18
For More Information.....	24

Hazardous Location Considerations

This equipment is suitable for use in Class I, Division 2, Groups A, B, C, D or non-hazardous locations only. The following WARNING statement applies to use in hazardous locations.

WARNING



EXPLOSION HAZARD

- Substitution of components may impair suitability for Class I, Division 2.
 - Do not replace components or disconnect equipment unless power has been switched off or the area is known to be non-hazardous.
 - Do not connect or disconnect components unless power has been switched off or the area is known to be non-hazardous.
 - All wiring must comply with N.E.C. article 501-4(b).
-

Environnements dangereux

Cet équipement est conçu pour être utilisé dans des environnements de Classe I, Division 2, Groupes A, B, C, D ou non dangereux. La mise en garde suivante s'applique à une utilisation dans des environnements dangereux.

WARNING



DANGER D'EXPLOSION

- La substitution de composants peut rendre cet équipement impropre à une utilisation en environnement de Classe I, Division 2.
 - Ne pas remplacer de composants ou déconnecter l'équipement sans s'être assuré que l'alimentation est coupée.
 - Ne pas connecter ou déconnecter des composants sans s'être assuré que l'alimentation est coupée.
-

Overview

The RTD module receives and stores digitally converted analog data from RTDs or other resistance inputs such as potentiometers into its image table for retrieval by all fixed and modular SLC 500 processors. An RTD consists of a temperature-sensing element connected by 2, 3 or 4 wires that provide input to the RTD module. The module supports connections from any combination of up to four RTDs of various types (for example: platinum, nickel, copper, or nickel-iron) or other resistance inputs. See the input specifications beginning on page 20 for RTD types, their associated temperature ranges, and the analog input signal ranges that each 1746-NR4 channel will support. Each input channel is individually configurable for a specific input device. Broken sensor detection (open- or short-circuit) is provided for each input channel. In addition, the module provides indication if the input signal is out-of-range.

The module contains a removable terminal block providing connection for any mix of four RTD sensors or resistance input devices. There are no output channels on the module. Module configuration is done via the user program. There are no DIP switches.

Channel Status LEDs

Channel status LEDs indicate the status for channels 0 through 3. Related error information is contained in the channel status word. This includes conditions such as:

- normal operation
- channel-related configuration errors
- open circuit errors
- out-of-range errors

All channel errors are recoverable errors.

Module Status LED

The module status LED shows diagnostic or operating errors related to the module. These non-recoverable errors may be detected during power up or during operation. Once an error has been detected, the module no longer communicates with the SLC processor. Channel states are disabled, and data words are cleared (0). Failure of any diagnostic test results in a non-recoverable error and requires the assistance of your local distributor or Rockwell Automation.

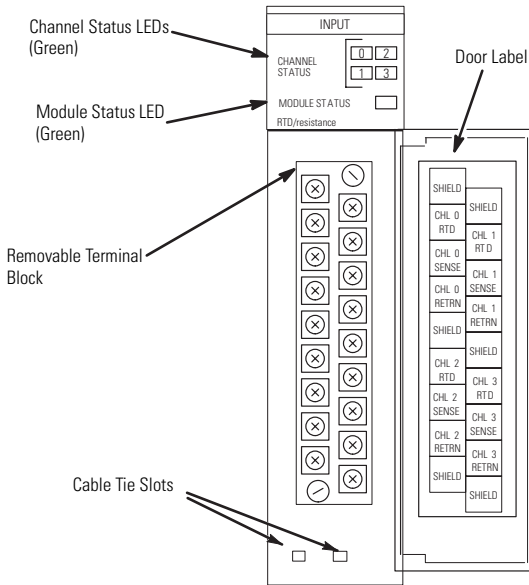

Required Tools and Equipment

Have the following tools and equipment ready

- medium blade screwdriver
- medium cross-head screwdriver
- RTD module (1746-NR4)
- RTD sensor or resistance input
- appropriate cable (if needed)
- programming equipment

Electrostatic Damage

Electrostatic discharge can damage semiconductor devices inside this module if you touch backplane connector pins or other sensitive areas. Guard against electrostatic damage by observing the following precautions.

ATTENTION

Electrostatic discharge can degrade performance or cause permanent damage. Handle the module as stated below.



- Wear an approved wrist strap grounding device when handling the module.
- Touch a grounded object to rid yourself of electrostatic charge before handling the module.
- Handle the module from the front, away from the backplane connector. Do not touch backplane connector pins.
- Keep the module in its static-shield bag when not in use, or during shipment.

NR4 Power Requirements

The RTD module receives its power through the SLC 500 chassis backplane from the fixed or modular +5V dc/+24V dc chassis power supply. The maximum current drawn by the module is shown in the table below.

5V dc Amps	24V dc Amps
0.050	0.050

When you are using a *modular system* configuration, add the values shown in the table above to the requirements of all other modules in the SLC chassis to prevent overloading the chassis power supply.

When you are using a *fixed system* controller, refer to the important note about module compatibility in a 2-slot fixed expansion chassis on page 6.

Modular Chassis Considerations

Place your RTD module in any slot of an SLC 500 modular chassis (except slot 0) or a modular expansion chassis. Slot 0 is reserved for the modular processor or adapter modules.

Fixed Expansion Chassis Considerations

IMPORTANT

The 2-slot, SLC 500 fixed I/O expansion chassis (1746-A2) supports many combinations of modules. The combinations that are *not* supported by the fixed expansion chassis are shown in the table below. For a complete listing of valid combinations using the RTD module in a 2-slot expansion chassis with another SLC I/O or communication module, refer to the table in the *SLC 500™ RTD/Resistance Input Module User Manual*, publication 1746-6.7.

Invalid Combinations Using the RTD Module in a Fixed Expansion Chassis	5V dc (Amps)	24V dc (Amps)
OW16	0.170	0.180
OB32	0.452	-
OB32	0.452	-

General Considerations

Most applications require installation in an industrial enclosure to reduce the effects of electrical interference. RTD inputs are susceptible to electrical noises due to the small amplitudes of their signal.

Group your modules to minimize adverse effects from radiated electrical noise and heat. Consider the following conditions when selecting a slot for the RTD module. Position the module:

- in a slot away from power lines, load lines and other sources of electrical noise such as hard-contact switches, relays, and AC motor drives
- away from modules which generate significant radiated heat, such as the 32-point I/O modules

Module Installation and Removal

When installing the module in a chassis, it is not necessary to remove the terminal block from the module.

Module Installation Procedure

1. Align the circuit board of the RTD module with the card guides located at the top and bottom of the chassis.
2. Slide the module into the chassis until both top and bottom retaining clips are secured. Apply firm even pressure on the module to attach it to its backplane connector. Never force the module into the slot.
3. Cover all unused slots with the Card Slot Filler, Catalog Number 1746-N2.

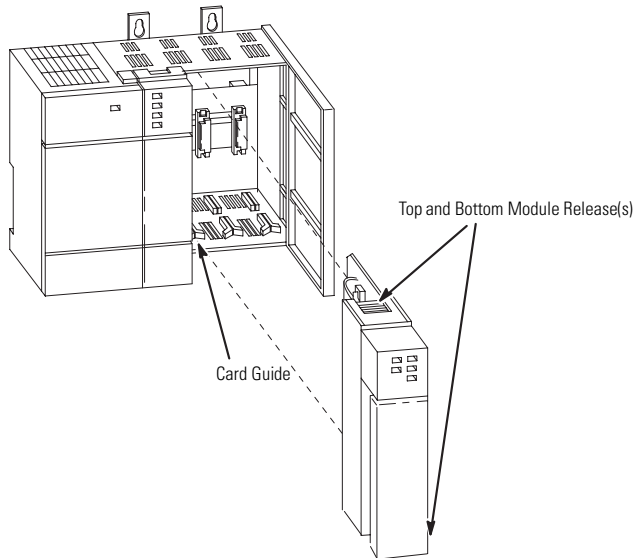

Module Removal Procedure

1. Press the releases at the top and bottom of the module and slide the module out of the chassis slot.
2. Cover all unused slots with the Card Slot Filler, Catalog Number 1746-N2.

Terminal Block Wiring and Removal

The RTD module contains an 18-position, removable terminal block. The terminal pin-out is shown below.



ATTENTION

Disconnect power to the SLC before attempting to install, remove, or wire the removable terminal wiring block. To avoid cracking the removable terminal block, alternate the removal of the terminal block release screws.

Terminal Wiring

Terminal screws accept a maximum of two #14 AWG (2 mm²) wires. Tighten terminal screws only tight enough to immobilize wires. Maximum torque on terminal screws is 0.7 to 0.9 Nm (6 to 8 in-lb.).

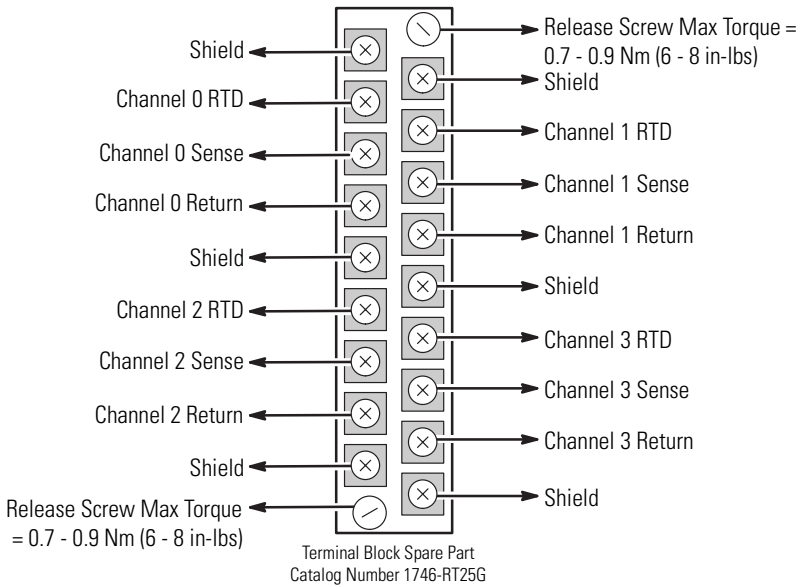

Terminal Block Removal

If the terminal block is removed, use the write-on label located on the side of the terminal block to identify the module location and type.

To remove the terminal block:

1. Loosen the two terminal block release screws.
2. Grasp the terminal block at the top and bottom and pull outward and down.

Wiring Considerations

Follow the guidelines below when planning your system wiring.

Since the operating principle of the RTD module is based on the measurement of resistance, take special care in selecting your input cable. For 2-wire or 3-wire configuration, select a cable that has a consistent impedance throughout its entire length.

Configuration	Recommended Cable
2-wire	Belden™ #9501 or equivalent
3-wire less than 30.48 m (100 ft.)	Belden #9533 or equivalent
3-wire greater than 30.48 m (100 ft.) or high humidity conditions	Belden #83503 or equivalent

For a 3-wire configuration, the module can compensate for a maximum cable length associated with an overall cable impedance of 25 ohms.

As shown in the figure on the next page, three configurations of RTDs can be connected to the RTD module:

- 2-wire RTD, which is composed of 2 RTD lead wires (RTD and Return)
- 3-wire RTD, which is composed of a Sense and 2 RTD lead wires (RTD and Return)
- 4-wire RTD, which is composed of 2 Sense and 2 RTD lead wires (RTD and Return). The second sense wire of a 4-wire RTD is left open. It does not matter which sense wire is left open.

2-Wire RTD Interconnection

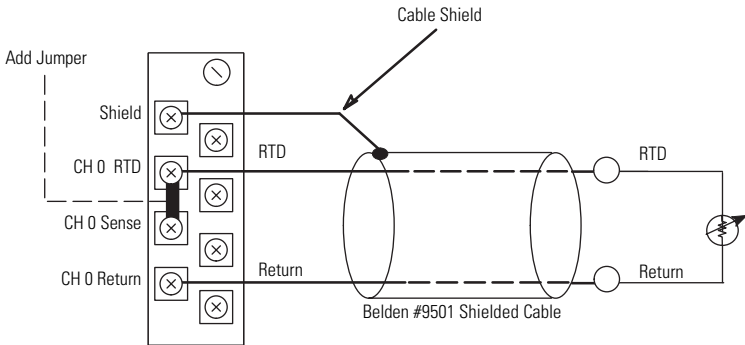

3-Wire RTD Interconnection

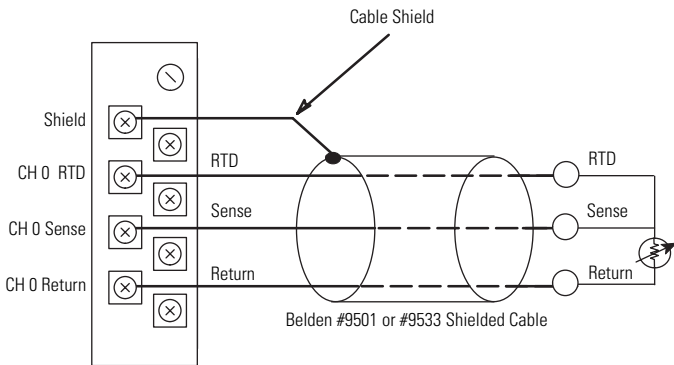

4-Wire RTD Interconnection

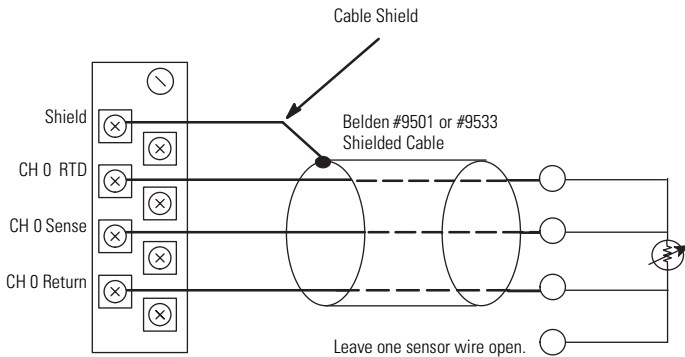

IMPORTANT

The RTD module requires three wires to compensate for lead resistance error. We recommend that you *do not* use 2-wire RTDs if long cable runs are required, as it will reduce the accuracy of the system. However, if a 2-wire configuration is required, reduce the effect of the lead wire resistance by using a lower gauge wire for the cable (for example, use AWG #16 instead of AWG #24). Also, use cable that has a lower resistance per foot of wire. The module's terminal block accepts two AWG #14 gauge wires.

- To limit overall cable impedance, keep input cables as short as possible. Locate your I/O chassis as near the RTD sensors as your application will permit.
- Ground the shield drain wire at one end only. The preferred location is at the RTD module. Refer to IEEE Std. 518, Section 6.4.2.7 or contact your sensor manufacturer for additional details.
- Each input channel has a shield connection screw terminal that provides a connection to chassis ground. All shields are internally connected, so any shield terminal can be used with channels 0 to 3.
- Route RTD/resistance input wiring away from any high-voltage I/O wiring, power lines, and load lines.
- Tighten terminal screws using a flat or cross-head screwdriver. Each screw should be turned tight enough to immobilize the wire's end. Excessive tightening can strip the terminal screw. The torque applied to each screw should not exceed 0.7 to 0.9 Nm (6 to 8 in-lb.) for each terminal.
- Follow system grounding and wiring guidelines found in your *SLC 500 Modular Hardware Style User Manual*, publication 1747-6.2.

When using a 3-wire configuration, the module compensates for resistance error due to lead wire length. For example, in a 3-wire configuration, the module reads the resistance due to the length of one of the wires and assumes that the resistance of the other wire is equal. If the resistances of the individual lead wires are much different, an error may exist. The closer the resistance values are to each other, the greater the amount of error that is eliminated.

IMPORTANT

To ensure temperature or resistance value accuracy, the resistance difference of the cable lead wires must be equal to or less than 0.01Ω.

There are several ways to insure that the lead values match as closely as possible. They are as follows:

- Keep lead resistance as small as possible and less than 25Ω.
- Use quality cable that has a small tolerance impedance rating.
- Use a heavy-gauge lead wire which has less resistance per foot.

Wiring Resistance Devices (Potentiometers) to the NR4 Module

Potentiometer wiring requires the same type of cable as that for the RTD described on page 9. Potentiometers can be connected to the RTD module as a 2-wire interconnection or a 3-wire interconnection as shown on the following pages.

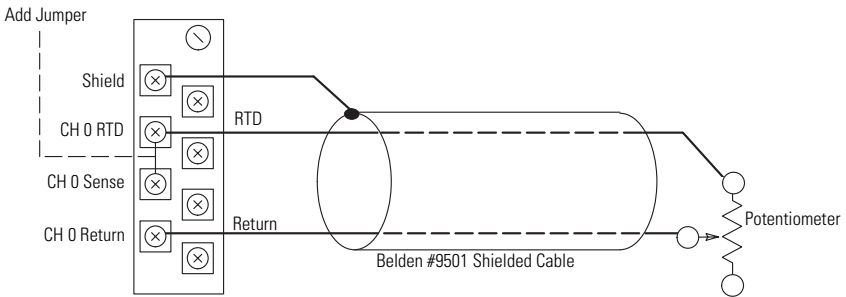
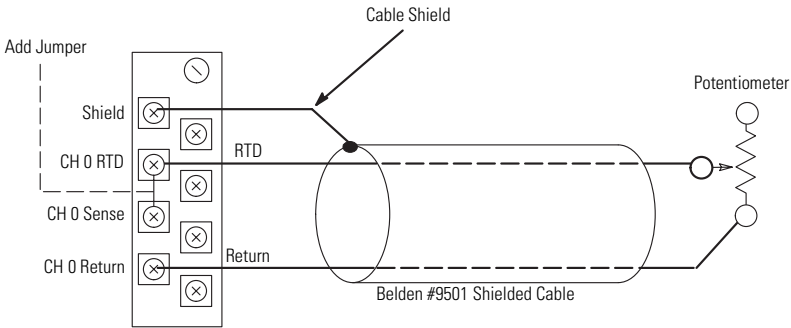

TIP



Potentiometer wiper arm can be connected to either the RTD or Return terminal, depending on whether you want increasing or decreasing resistance.

3-Wire Potentiometer Interconnection

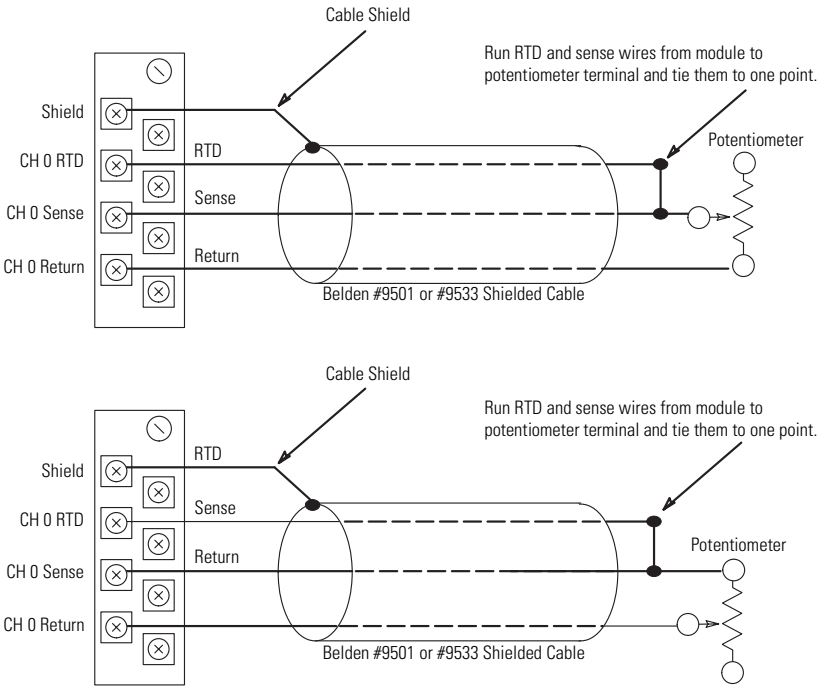

TIP

Potentiometer wiper arm can be connected to either the RTD or Return terminal, depending on whether you want increasing or decreasing resistance.

Wiring Input Devices to the NR4 Module

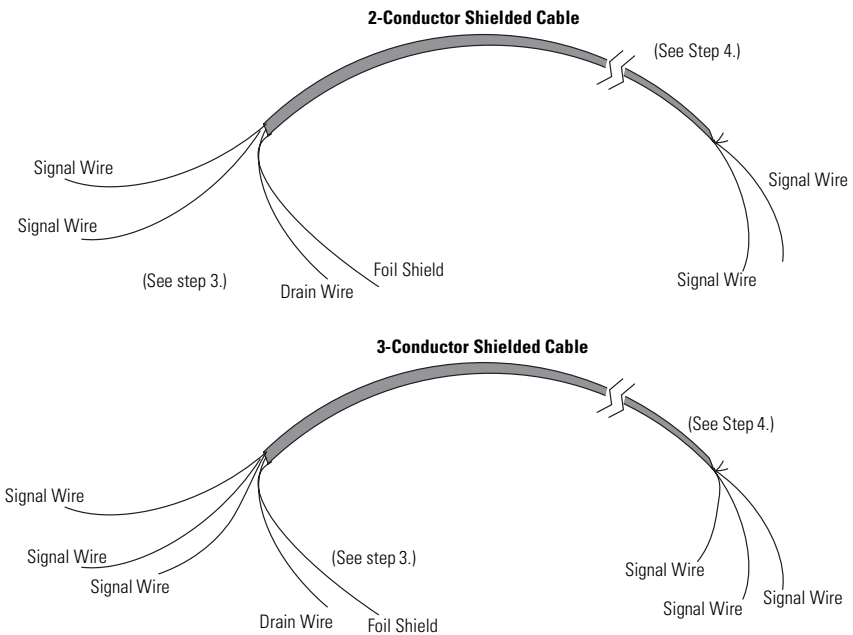

To wire your NR4 module, follow these steps.

1. At each end of the cable, strip some casing to expose the individual wires.
2. Trim the signal wires to 5.08 cm (2 in.) lengths. Strip about 4.76 mm (3/16 in.) of insulation away to expose the end of the wire.
3. At one end of the cable twist the drain wire and foil shield together, bend them away from the cable, and apply shrink wrap. Then earth ground at the shield terminal.
4. At the other end of the cable, cut the drain wire and foil shield back to the cable and apply shrink wrap.
5. Connect the signal wires and cable shield to the NR4 terminal block and the input.
6. Repeat steps 1 through 5 for each channel on the NR4 module.

Module Addressing

The following memory map shows you how the output and input image tables are defined for the RTD module.

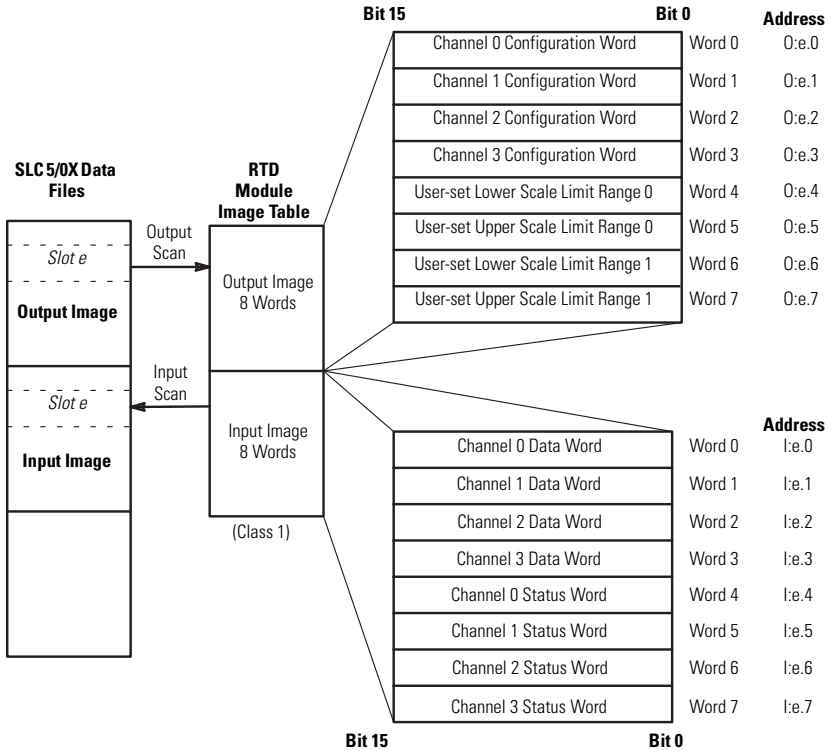

Channel Configuration

Once the module is installed, each channel can be configured to establish the way the channel will operate. You configure the channel by entering bit values into the configuration word using your programming software. Channels 0 through 3 on the NR4 are configured by entering bit values into output words 0 through 3 respectively. Output words 4 through 7 are used to further define the channel configuration to allow you to choose a scaling format other than the module default when using the proportional counts format. You can use words 4 and 5 to define one user-set range. Use words 6 and 7 to define a second range. See the table below for a bit-by-bit examination of the configuration word.

To Select		Make these bit settings															
		15	14	13	12	11	10	9	8	7	6	5	4	3	2	1	0
Input Type	100Ω Pt 385												0	0	0	0	
	200Ω Pt 385												0	0	0	1	
	500Ω Pt 385												0	0	1	0	
	1000Ω Pt 385												0	0	1	1	
	100Ω Pt 3916												0	1	0	0	
	200Ω Pt 3916												0	1	0	1	
	500Ω Pt 3916												0	1	1	0	
	1000Ω Pt 3916												0	1	1	1	
	10Ω Cu 426 ⁽¹⁾												1	0	0	0	
	120Ω Ni 618 ⁽²⁾												1	0	0	1	
	120Ω Ni 672												1	0	1	0	
	604Ω NiFe 518												1	0	1	1	
	150Ω												1	1	0	0	
	500Ω												1	1	0	1	
	1000Ω												1	1	1	0	
3000Ω												1	1	1	1		
Data Format	Engineering Units 1 ⁽³⁾											0	0				
	Engineering Units 10 ⁽⁴⁾											0	1				
	Scaled-for-PID											1	0				
	Raw/Proportional											1	1				
Broken Input	Set to Zero											0	0				
	Set to Upscale											0	1				
	Set to Downscale											1	0				
	Invalid											1	1				
Temperature Units ⁽⁵⁾	°C										0						
	°F										1						

To Select		Make these bit settings															
		15	14	13	12	11	10	9	8	7	6	5	4	3	2	1	0
Filter Frequency	10 Hz						0	0									
	50 Hz						0	1									
	60 Hz						1	0									
	250Hz						1	1									
Enable Channel	Enable					1											
	Disable					0											
Excitation Current	2.0 mA				0												
	0.5 mA				1												
Scaling	Default		0	0													
	User-set (Range 0) ⁽⁶⁾		0	1													
	User-set (Range 1) ⁽⁶⁾		1	0													
	Invalid		1	1													
Unused		0															

(1) Actual value at 0°C is 9.042Ω per SAMA standard RC21-4-1966.

(2) Actual value at 0°C is 100Ω per DIN standard.

(3) Values are in 0.1 degree/step or 0.1Ω/step for all resistance input types, except 150Ω. For the 150Ω resistance type, the values are in 0.01Ω/step.

(4) Values are in 1 degree/step or 1Ω/step for all resistance input types, except 150Ω. For the 150Ω resistance input type, the values are in 0.1Ω/step.

(5) This bit is ignored when a resistance device is selected.

(6) Applies to proportional counts data format selected using bits 4 and 5.

TIP

Ensure that unused bit 15 is always set to zero.



Specifications

Electrical Specifications

Backplane Current Consumption	50 mA at 5V dc 50 mA at 24V dc
Backplane Power Consumption	1.5W maximum (0.3 W at 5V dc, 1.2 W at 24V dc)
External Power Supply Requirements	None
Number of Channels	4 (backplane isolated)
I/O Chassis Location	Any I/O module slot except slot 0
A/D Conversion Method	Sigma-Delta Modulation
Input Filtering	Low pass digital filter with programmable notch (filter) frequencies
Common Mode Rejection (between inputs and chassis ground)	> 150 dB at 50 Hz (10 Hz and 50 Hz filter frequencies) > 150 dB at 60 Hz (10 Hz and 60 Hz filter frequencies)
Normal Mode Rejection (between [+] input and [-] input)	Greater than 100 dB at 50 Hz (10 Hz, 50 Hz filter frequencies) Greater than 100 dB at 60 Hz (10 Hz, 60 Hz filter frequencies)
Max. common mode voltage	± 1 volt
Max. allowed permanent overload ⁽¹⁾	Volts = ± 5V dc; Current = ± 5 mA
Input Filter Cut-Off Frequencies	2.62 Hz at 10 Hz filter frequency 13.1 Hz at 50 Hz filter frequency 15.72 Hz at 60 Hz filter frequency 65.5 Hz at 250 Hz filter frequency
Calibration	Module autocalibrates when a channel is enabled or when a change is made to its input type, filter frequency or excitation current.
Isolation (optical)	500V dc for 1 min. between inputs and chassis ground, and between inputs and backplane
Isolation Between Inputs	None

(1) Do not apply a voltage or current to the module.

Physical Specifications

LED Indicators	5 green status indicators, one for each of 4 channels and one for module status
Module ID Code	3513
Maximum Termination Wire Size	Two 14 AWG wire per terminal
Maximum Cable Impedance	25 ohms maximum impedance for 3-wire RTD configuration (see Cable Specifications)
Terminal Block	Removable, Allen-Bradley spare part Cat. No. 1746-RT25G

Module Environmental Specifications

Operating Temperature	0°C to +60°C (+32°F to +140°F)
Storage Temperature	-40°C to +85°C (-40°F to +185°F)
Relative Humidity	5% to 95% (without condensation)
Hazardous Environment Classification	Class I, Division 2 Hazardous Environment
Agency Certification (when product or packaging is marked)	<ul style="list-style-type: none"> • UL /CSA Class I, Division 2 Groups A, B, C, D certified • CE compliant for all applicable directives

Input Specifications

RTD Types	platinum, nickel, nickel iron, copper (For additional information on RTD types, see page 21.)
Temperature Scale (Selectable)	°C or °F and 0.1°C or 0.1°F
Resistance Scale (Selectable)	1Ω or 0.1Ω for all resistance ranges; or 0.1Ω or 0.01Ω for 150Ω potentiometer.
Input Step Response	Refer to the <i>SLC 500™ RTD/Resistance Input Module User Manual</i> , 1746-6.7.
Channel Turn-On Time	Requires up to one module update time <i>plus</i> one of the following: <ul style="list-style-type: none"> • 250 Hz Filter = 388 milliseconds • 60 Hz Filter = 1,300 milliseconds • 50 Hz Filter = 1,540 milliseconds • 10 Hz Filter = 7,300 milliseconds
Channel Turn-Off Time	Requires up to one module update time.
Reconfiguration Time	Requires up to one module update time <i>plus</i> one of the following: <ul style="list-style-type: none"> • 250 Hz Filter = 124 milliseconds • 60 Hz Filter = 504 milliseconds • 50 Hz Filter = 604 milliseconds • 10 Hz Filter = 3,004 milliseconds
RTD Excitation Current	Two current values are user-selectable: <ul style="list-style-type: none"> • 0.5 mA - Recommended for use with higher resistance ranges for both RTDs and direct resistance inputs (1000Ω RTDs and 3000Ω resistance input). Refer to RTD manufacturer for recommendations. Cannot use for 10Ω Copper RTD. • 2.0 mA - Must use for 10Ω Copper RTD. Recommended for use for all other RTD and direct resistance inputs, except 1000Ω RTDs and 3000Ω resistance input ranges are limited. Refer to RTD manufacturer for recommendations.

RTD Temperature Ranges, Resolution, and Repeatability

RTD Type		Temp. Range (0.5 mA Excitation) ⁽⁴⁾	Temp. Range (2.0 mA Excitation)	Resolution	Repeatability
Platinum (385) ⁽¹⁾	100Ω	-200 °C to +850 °C (-328 °F to +1562 °F)	-200 °C to +850 °C (-328 °F to +1562 °F)	0.1 °C (0.2 °F)	±0.2 °C (± 0.4 °F)
	200Ω	-200 °C to +850 °C (-328 °F to +1562 °F)	-200 °C to +850 °C (-328 °F to +1562 °F)	0.1 °C (0.2 °F)	± 0.2 °C (± 0.4 °F)
	500Ω	-200 °C to +850 °C (-328 °F to +1562 °F)	-200 °C to +850 °C (-328 °F to +1562 °F)	0.1 °C (0.2 °F)	± 0.2 °C (± 0.4 °F)
	1000Ω	-200 °C to +850 °C (-328 °F to +1562 °F)	-200 °C to +240 °C (-328 °F to +464 °F)	0.1 °C (0.2 °F)	± 0.2 °C (±0.4 °F)
Platinum (3916) ⁽¹⁾	100Ω	-200 °C to +630 °C (-328 °F to +1166 °F)	-200 °C to +630 °C (-328 °F to +1166 °F)	0.1 °C (0.2 °F)	± 0.2 °C (± 0.4 °F)
	200Ω	-200 °C to +630 °C (-328 °F to +1166 °F)	-200 °C to +630 °C (-328 °F to +1166 °F)	0.1 °C (0.2 °F)	± 0.2 °C (± 0.4 °F)
	500Ω	-200 °C to +630 °C (-328 °F to +1166 °F)	-200 °C to +630 °C (-328 °F to +1166 °F)	0.1 °C (0.2 °F)	± 0.2 °C (± 0.4 °F)
	1000Ω	-200 °C to +630 °C (-328 °F to +1166 °F)	-200 °C to +230 °C (-328 °F to +446 °F)	0.1 °C (0.2 °F)	± 0.2 °C (± 0.4 °F)
Copper (426) ⁽¹⁾⁽²⁾	10Ω	Not allowed. ⁽⁵⁾	-100 °C to +260 °C (-148 °F to +500 °F)	0.1 °C (0.2 °F)	± 0.2 °C (± 0.4 °F)
Nickel (618) ⁽¹⁾⁽³⁾	120Ω	-100 °C to +260 °C (-148 °F to +500 °F)	-100 °C to +260 °C (-148 °F to +500 °F)	0.1 °C (0.2 °F)	± 0.1 °C (± 0.2 °F)
Nickel (672)	120Ω	-80 °C to +260 °C (-112 °F to +500 °F)	-80 °C to +260 °C (-112 °F to +500 °F)	0.1 °C (0.2 °F)	± 0.1 °C (± 0.2 °F)
Nickel Iron (518)	604Ω	-100 °C to +200 °C (-148 °F to +392 °F)	-100 °C to +200 °C (-148 °F to +392 °F)	0.1 °C (0.2 °F)	± 0.1 °C (± 0.2 °F)

(1) The digits following the RTD type represent the temperature coefficient of resistance (α), which is defined as the resistance change per ohm per °C. For instance, Platinum 385 refers to a platinum RTD with $\alpha = 0.00385$ ohms/ohm - °C or simply 0.00385/°C.

(2) Actual value at 0°C is 9.042Ω per SAMA standard RC21-4-1966.

(3) Actual value at 0°C is 100Ω per DIN standard.

(4) The temperature range for the 1000Ω RTD is dependent on the excitation current.

(5) To maximize the relatively small RTD signal, only 2 mA excitation current is allowed.

RTD Accuracy and Temperature Drift Specifications

RTD Type		Accuracy ⁽⁴⁾ (0.5 mA Excitation)	Accuracy ⁽⁴⁾ (2.0 mA Excitation)	Temperature Drift ⁽⁶⁾ (0.5 mA Excitation)	Temperature Drift ⁽⁶⁾ (2.0 mA Excitation)
Platinum (385) ⁽¹⁾	100Ω	± 1.0 °C (± 2.0 °F)	± 0.5 °C (± 0.9 °F)	± 0.034 °C/°C (± 0.061 °F/°F)	± 0.014 °C/°C (± 0.025 °F/°F)
	200Ω	± 1.0 °C (± 2.0 °F)	± 0.5 °C (± 0.9 °F)	± 0.034 °C/°C (± 0.061 °F/°F)	± 0.014 °C/°C (± 0.025 °F/°F)
	500Ω	± 0.6 °C (± 1.1 °F)	± 0.5 °C (± 0.9 °F)	± 0.017 °C/°C (± 0.031 °F/°F)	± 0.014 °C/°C (± 0.025 °F/°F)
	1000Ω	± 0.6 °C (± 1.1 °F)	± 0.5 °C (± 0.9 °F)	± 0.017 °C/°C (± 0.031 °F/°F)	± 0.014 °C/°C (± 0.025 °F/°F)
Platinum (3916) ⁽¹⁾	100Ω	± 1.0 °C (± 2.0 °F)	± 0.4 °C (± 0.7 °F)	± 0.034 °C/°C (± 0.061 °F/°F)	± 0.011 °C/°C (± 0.020 °F/°F)
	200Ω	± 1.0 °C (± 2.0 °F)	± 0.4 °C (± 0.7 °F)	± 0.034 °C/°C (± 0.061 °F/°F)	± 0.011 °C/°C (± 0.020 °F/°F)
	500Ω	± 0.5 °C (± 0.9 °F)	± 0.4 °C (± 0.7 °F)	± 0.014 °C/°C (± 0.025 °F/°F)	± 0.011 °C/°C (± 0.020 °F/°F)
	1000Ω	± 0.5 °C (± 0.9 °F)	± 0.4 °C (± 0.7 °F)	± 0.014 °C/°C (± 0.025 °F/°F)	± 0.011 °C/°C (± 0.020 °F/°F)
Copper (426) ⁽¹⁾⁽²⁾	10Ω	Not allowed. ⁽⁵⁾	± 0.6 °C (± 1.1 °F)	Not allowed. ⁽⁵⁾	± 0.017 °C/°C (± 0.031 °F/°F)
Nickel (618) ⁽¹⁾⁽³⁾	120Ω	± 0.2 °C (± 0.4 °F)	± 0.2 °C (± 0.4 °F)	± 0.008 °C/°C (± 0.014 °F/°F)	± 0.008 °C/°C (± 0.014 °F/°F)
Nickel (672) ⁽¹⁾	120Ω	± 0.2 °C (± 0.4 °F)	± 0.2 °C (± 0.4 °F)	± 0.008 °C/°C (± 0.014 °F/°F)	± 0.008 °C/°C (± 0.014 °F/°F)
Nickel Iron (518) ⁽¹⁾	604Ω	± 0.3 °C (± 0.5 °F)	± 0.3 °C (± 0.5 °F)	± 0.010 °C/°C (± 0.018 °F/°F)	± 0.010 °C/°C (± 0.018 °F/°F)

(1) The digits following the RTD type represent the temperature coefficient of resistance (α), which is defined as the resistance change per ohm per °C. For instance, Platinum 385 refers to a platinum RTD with $\alpha = 0.00385$ ohms/ohm - °C or simply 0.00385/°C.

(2) Actual value at 0°C is 9.042Ω per SAMA standard RC21-4-1966.

(3) Actual value at 0°C is 100Ω per DIN standard.

(4) The accuracy values assume that the module was calibrated within the specified temperature range of 0°C to 60°C (32°F to 140°F).

(5) To maximize the relatively small RTD signal, only 2 mA excitation current is allowed.

(6) Temperature drift specifications apply to a module that has not been calibrated.

When you are using 100Ω or 200Ω platinum RTDs with 0.5 mA excitation current, refer to the important note on the next page about module accuracy.

IMPORTANT

Module accuracy, using 100 Ω or 200 Ω platinum RTDs with 0.5 mA excitation current, depends on the following criteria:

- Module accuracy is $\pm 0.6^{\circ}\text{C}$ after you apply power to the module or perform an autocalibration at 25 $^{\circ}\text{C}$ ambient with module operating temperature at 25 $^{\circ}\text{C}$.
- Module accuracy is $\pm (0.6^{\circ}\text{C} + \text{DT} \times 0.034^{\circ}\text{C}/^{\circ}\text{C})$ after you apply power to the module or perform an autocalibration at 25 $^{\circ}\text{C}$ ambient with the module operating temperature between 0 $^{\circ}$ to 60 $^{\circ}\text{C}$.
 - where DT is the temperature difference between the actual operating temperature of the module and 25 $^{\circ}\text{C}$ and 0.034 $^{\circ}\text{C}/^{\circ}\text{C}$ is the temperature drift shown in the table on page 22 for 100 Ω or 200 Ω platinum RTDs.
- Module accuracy is $\pm 1.0^{\circ}\text{C}$ after you apply power to the module or perform an autocalibration at 60 $^{\circ}\text{C}$ ambient with module operating temperature at 60 $^{\circ}\text{C}$.

For More Information

For	Refer to this Document	Pub. No.
A more detailed description on how to install and use your RTD/Resistance Input Module.	SLC 500 RTD/Resistance Input Module User Manual	1746-6.7
A more detailed description on how to install and use your modular SLC 500 system.	SLC 500 Module Hardware Style User Manual	1747-6.2
A more detailed description on how to install and use your fixed SLC 500 system.	SLC 500 Fixed Hardware Style Installation and Operation Manual	1747-6.21
A reference manual that contains status file data, instruction set, and troubleshooting information.	SLC 500 Instruction Set Reference Manual	1747-RM001

You can view or download publications at <http://literature.rockwellautomation.com>.

Rockwell Automation, Allen-Bradley, SLC 500, and MicroLogix are trademarks of Rockwell Automation, Inc.

Trademarks not belonging to Rockwell Automation are property of their respective companies.

www.rockwellautomation.com

Power, Control and Information Solutions Headquarters

Americas: Rockwell Automation, 1201 South Second Street, Milwaukee, WI 53204-2496 USA, Tel: (1) 414.382.2000, Fax: (1) 414.382.4444

Europe/Middle East/Africa: Rockwell Automation, Vorstlaan/Boulevard du Souverain 36, 1170 Brussels, Belgium, Tel: (32) 2 663 0600, Fax: (32) 2 663 0640

Asia Pacific: Rockwell Automation, Level 14, Core F, Cyberport 3, 100 Cyberport Road, Hong Kong, Tel: (852) 2887 4788, Fax: (852) 2508 1846

Publication 1746-IN012B-EN-P - May 2001

PN 40071-133-01(B)

Supersedes Publication 1747-5.17 - July 1999

Copyright © 2007 Rockwell Automation, Inc. All rights reserved. Printed in Singapore.