

Section 1 ■ Installation

Section 2 ■ After installation

Section 3 ■ Facts about VLT

Section 1

Section 2

Section 3



Section 1

Installation has been written for personnel who will unpack the VLT frequency converter and carry out mechanical and electrical installation.

Installation makes it easy and safe for you to install the VLT frequency converter, just follow the instructions on the next pages.

Section 2

After Installation has been written for personnel who are to set up the VLT frequency converter, when it is to be commissioned. The VLT has a number of factory settings. You can choose the settings to match your plant (application). The initial settings are described in chapter 1.

When you start your setting the mechanical and electrical installation has been done. If you want to check the electrical installation you can do that on the basis of the survey of terminals.

To go on with the settings you must know the values of the different parameters. Typically it is the planning engineer or technician who determines the values on the basis of the information given in the section Facts about VLT.

Section 3

Facts about VLT is written for users of VLT frequency converters for large plants.

In Facts about VLT you can read how to size a plant, how to select the right VLT on the basis of the technical data, how to carry out the electrical installation, the mechanical installation, etc.

It will also appear what standards the VLT frequency converter complies with and what safety measures you should take before you start.

Facts about VLT is your work of reference, so do keep it within reach.

When you read the manual please note the following symbols:



General warning



Pay special attention here.

-  The frequency converter contains dangerous voltages when connected to the mains. Improper connection of the motor or the frequency converter may cause equipment failure, serious injury or death.

Therefore follow the directions in this manual, as well as local and national safety rules.

Touching the electrical parts, even when the power supply has been switched off, can cause serious injury or death.

Wait at least 4 minutes after switching off before touching any electrical parts.

■ These rules concern your safety

1. When repairs are undertaken the power supply to the frequency converter must be disconnected.
2. The “Stop/Reset” key on the keyboard of the frequency converter does not disconnect the power supply and may therefore not be used as a safety switch.
3. The unit must be properly grounded, the user must be protected against supply voltage and the motor against overload according to national and local codes.
4. The leakage currents to ground are higher than 3 mA.
5. The factory setting does not incorporate protection against motor overload. For this function parameter 315 is set to data value *Trip* [2] or data value *Warning* [1]. Note: This function is initialised at 1.16 x rated motor current and rated motor frequency (see page 63).
6. Do not remove the motor and mains terminals, when the unit is connected to the mains. Ensure that the power supply has been switched off, before you remove the motor and mains terminals.

■ Warning against improper start

1. The motor can be stopped using digital commands, bus commands, references or local stop, while the frequency converter is connected to the mains. If personal safety requires elimination of any possibility of unintended start, these stops will not be sufficient.
2. The motor can start during parameter operation. Therefore always activate the “Stop/Reset” key before changing data.
3. A stopped motor can start if a fault occurs in the electronics of the frequency converter or after a temporary overload, mains fault or faulty motor connection.

■ For the North American market

CAUTION: It is the responsibility of the user or person installing the drive to provide proper grounding and branch circuit protection for incoming power and motor overload according to National Electrical Codes (NEC) and local codes.

The Electronic Thermal Relay (ETR) in UL listed VLTs provides class 20 motor overload protection in accordance with NEC in single motor applications, when parameter 315 is set to *Trip* [2] and parameter 107 is set to nominal motor (nameplate) current.

Chapter 1

- Before you start Page 6
- Mechanical installation Page 6
- Electrical installation Page 6
- EMC-correct installation Page 9
- General Page 9
- Instructions for installation Page 9
- For further information Page 11
- Installation guide
 - VLT 2000 with built-in compact RFI filter ... Page 12
- Technical data
 - VLT 2000 with built-in compact RFI-filter ... Page 12

■ **Before you start**

Read the safety rules on **page 4** before you start.

■ **Mechanical installation**

Item 1 *Drilling template (enclosed in box)*

That I have done

For sizing and drilling of holes you can use the enclosed Drilling Template.



Ensure min. 100 mm (10 cm) free air space above and below the VLT frequency converter. This also applies when a module has been mounted. Make sure that the ambient temperature does not exceed 40°C.

Item 2 *Side by side mounting*

VLT frequency converters can be mounted side by side, without any space between them.

Item 3 *Module*

If you want to use a module (to be placed underneath) you must take the physical dimensions into account.

■ **Electrical installation**

Item 1 *Prefuses*

Choose the right prefuses:

That I have done

Mains supply 1 x 220/230/240 V
3 x 208/220/230/240 V

Mains supply 3 x 380-460 V

VLT 2010	Max. 10A
VLT 2015	Max. 16 A
VLT 2020	Max. 20 A
VLT 2030	Max. 20 A
VLT 2040	Max. 20 A
VLT 2050	Max. 25 A

VLT 2020	Max. 16 A
VLT 2025	Max. 16 A
VLT 2030	Max. 16 A
VLT 2040	Max. 16 A
VLT 2050	Max. 16 A
VLT 2060	Max. 20 A

See Special conditions: Cut-in current

■ Electrical installation (continued)

Item 2 Extra protection

If you want extra protection, pay attention to the following:

As extra protection, error voltage relays or neutral grounding can be used. However, the installation must comply with local health and safety standards. An earth fault can introduce a direct current in the discharge current. Any ELGB relay used must comply with local regulations. The relays must be suitable to protect three-phase equipment with bridge rectifier and short discharge on power-up.

Item 3 Motor, mains and brake cables

To comply with the stated EMC emission specifications, screened motor cable must not be used. However, a precondition is that an RFI filter module is installed to comply with the EMC emission specifications.

Observe the following max. cross sections for motor, mains and brake cables:

That I have done

Mains supply 1 x 220/230/240 V
3 x 208/220/230/240 V

VLT 2010	Max. 4 mm ²
VLT 2015	Max. 4 mm ²
VLT 2020	Max. 4 mm ²
VLT 2030	Max. 4 mm ²
VLT 2040	Max. 4 mm ²
VLT 2050	Max. 4 mm ²

Mains supply 3 x 380-460 V

VLT 2020	Max. 4 mm ²
VLT 2025	Max. 4 mm ²
VLT 2030	Max. 4 mm ²
VLT 2040	Max. 4 mm ²
VLT 2050	Max. 4 mm ²
VLT 2060	Max. 4 mm ²

DANFOSS
195HA026.12

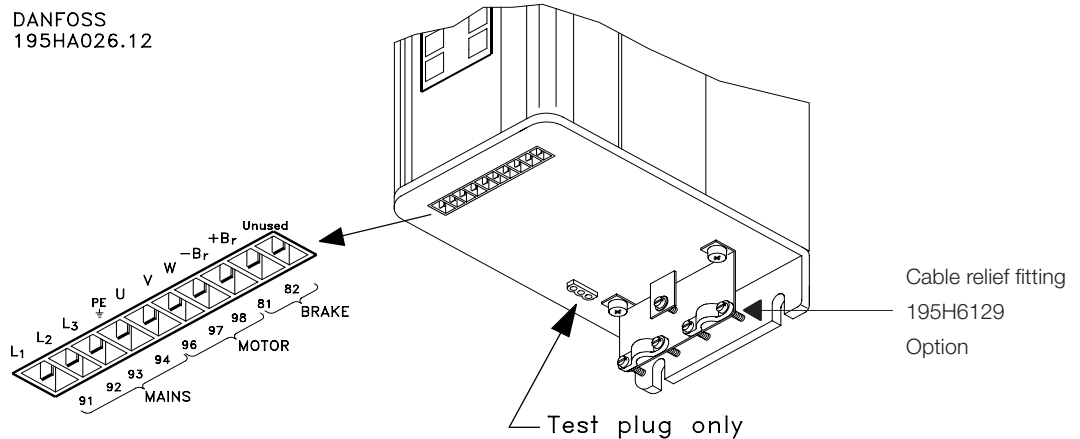

■ **Electrical installation** (continued)

Item 4 Control cables

That I have done ✓



The cables used for control cables must be screened to comply with the stated EMC emission specifications. Connect the screen from the control cables to terminal 61 (ground).



Observe the following max. cross sections for control cables:

Mains supply 1 x 220/230/240 V
3 x 208/220/230/240 V

VLT 2010	Max. 1.5 mm ²
VLT 2015	Max. 1.5 mm ²
VLT 2020	Max. 1.5 mm ²
VLT 2030	Max. 1.5 mm ²
VLT 2040	Max. 1.5 mm ²
VLT 2050	Max. 1.5 mm ²

Mains supply 3 x 380-460 V

VLT 2020	Max. 1.5 mm ²
VLT 2025	Max. 1.5 mm ²
VLT 2030	Max. 1.5 mm ²
VLT 2040	Max. 1.5 mm ²
VLT 2050	Max. 1.5 mm ²
VLT 2060	Max. 1.5 mm ²

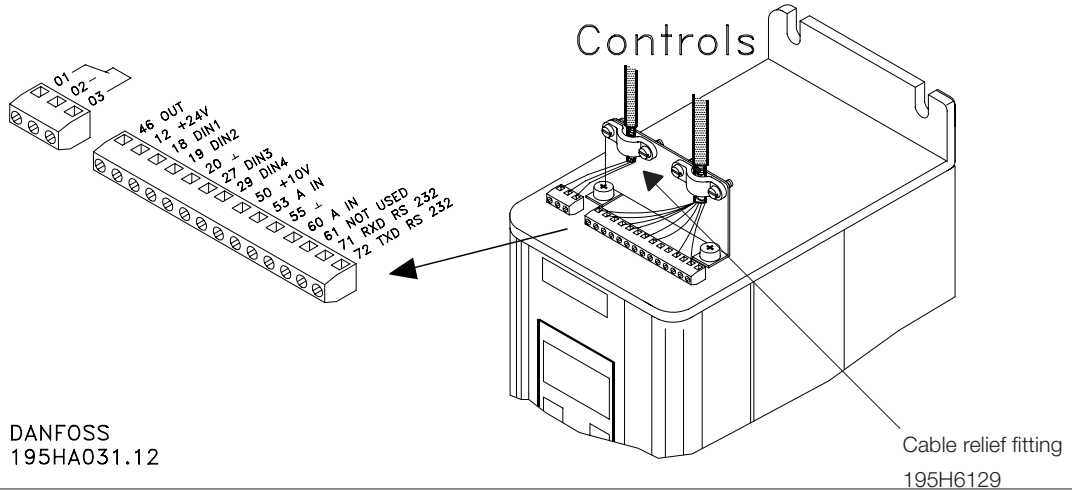

■ EMC correct installation

A number of factors must be considered in order to achieve EMC correct installation of the VLT 2000 frequency converter.

■ General

The basic VLT 2000 units do not comply with any EMC emission specifications, since no EMC filter (RFI filter) is incorporated in the basic units.

Therefore it is necessary to install an RFI and motor filter module to comply with EMC emission specifications.

VLT Series 2000 is available with built-in RFI filter that fulfils the EMC emission requirements.

In addition to reducing the mains interference, the filters also reduce the interference radiating from the unscreened motor cable. As far as the motor cable is concerned, only interference above 30 MHz is reduced (ref. EN 55011-1A).

To reduce the electromagnetic noise level from the total system as far as possible (frequency converter and motor installation), it is important to make the motor and brake cables as short as possible.

Cables having a sensitive noise level may not be led together with motor and brake cables.

■ How to install

Units with RFI and motor filter module:

When the RFI and motor filter module is installed it is recommended to use unscreened motor cable, since this gives the lowest electromagnetic noise level.

Control cable:

The control cable must be screened. The screen must be installed under the screen clamp on the screen termination bracket. Mounting with twisted screen ends (Pigtails) should be avoided, as this will destroy the screen effect at high frequencies.

Normally, the screen should also be connected to the base of the controlling appliance (follow the instructions for use of the appliance in question). In connection with very long control cables and analogue signals, 50 Hz ripple loops may occur in rare cases, depending on the installation. This is because of interference coupling from the mains supply cables. In this connection it can be necessary to break the screen or possible insert a 100nF condenser between screen and base.

Cable for serial communication:

The cable for serial communication should be screened. The screen should be installed using a screen clamp on the VLT frequency converter (see the instruction for installation, page 10, point (B)).

Motor cable:

For the motor either screened or unscreened cable can be used. In connection with installation of the RFI and motor filter module it is recommended to use unscreened motor cable. With screened motor cable, the screen must be installed under the cable clamp on the cable relief fitting. Mounting with twisted screen ends (Pigtails) should be avoided as this will destroy the screen effect at high frequencies. In principle the motor cable screen may not be interrupted and it may not be earth connected. If it is necessary to interrupt the screen to mount a motor starter or motor relays, the screen must continue with an impedance which is as low as possible.

The EMC emission specifications are complied with by using up to 100 m of unscreened motor cable.

If screened cable is used the demand for conducted noise (150 kHz - 30 MHz) cannot be observed.

Brake cable:

Screened cable must be used for the brake resistor. The screen must be installed under the cable clamp on the cable relief fitting. (See page 10 point (E)).

Avoid using screen pigtails.

Use brake cable lengths of up to 5 m.

Sensitive signal cables:

Cables having a sensitive noise level may not be led together with motor and brake cables.

Equalising currents:

Efforts should be made to avoid possible equalising currents that may occur when the control cable screen is connected to the base (earthed) at both ends. Equalising currents occur because of voltage differences between the VLT frequency converter base and the base of the controlling appliance. They can be avoided by making a tight fit with the cabinet base rear plate, thereby ensuring that any equalising currents will run via the base rear plates and their joints, not via the cable screens.

Installation

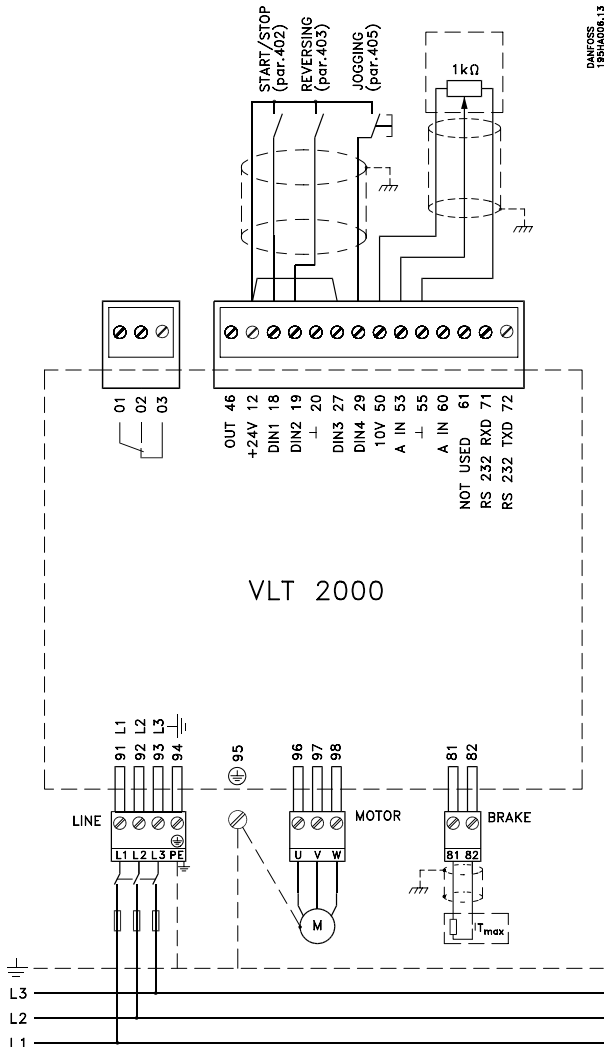

DANFOSS
195HA08.13

Three-phase mains connection

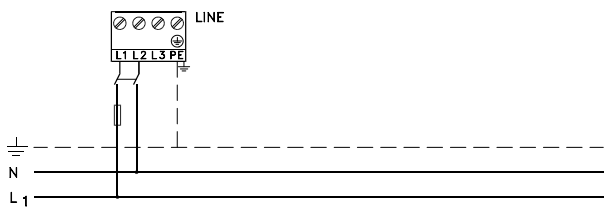

Single-phase mains connection

Between PC and VLT frequency converter

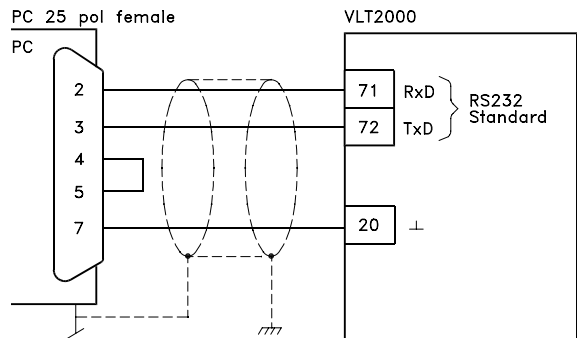
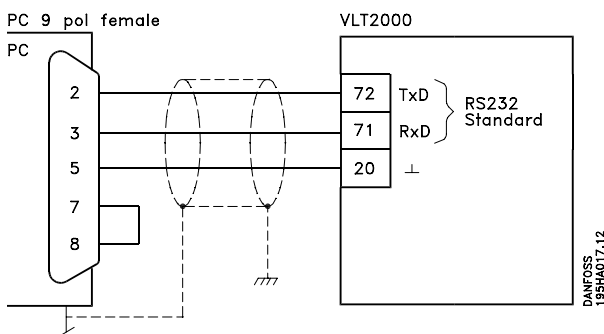

VLT 2010-2030, 1/3 x 208-240 V and VLT 2020-2060* 3 x 380-460 V with RFI and motor filter module or LC and RFI filter module:

If VLT frequency converters are mounted on an electrically conductive, metal rear plate, good electrical connection between the VLT and the rear plate is to be ensured (use earth screw (item **A**) in the drawing)).

If the VLT frequency converter is mounted on a non-conductive rear plate, it is to be ensured that there is good grounding to the earth screw (item **A**) in the drawing).

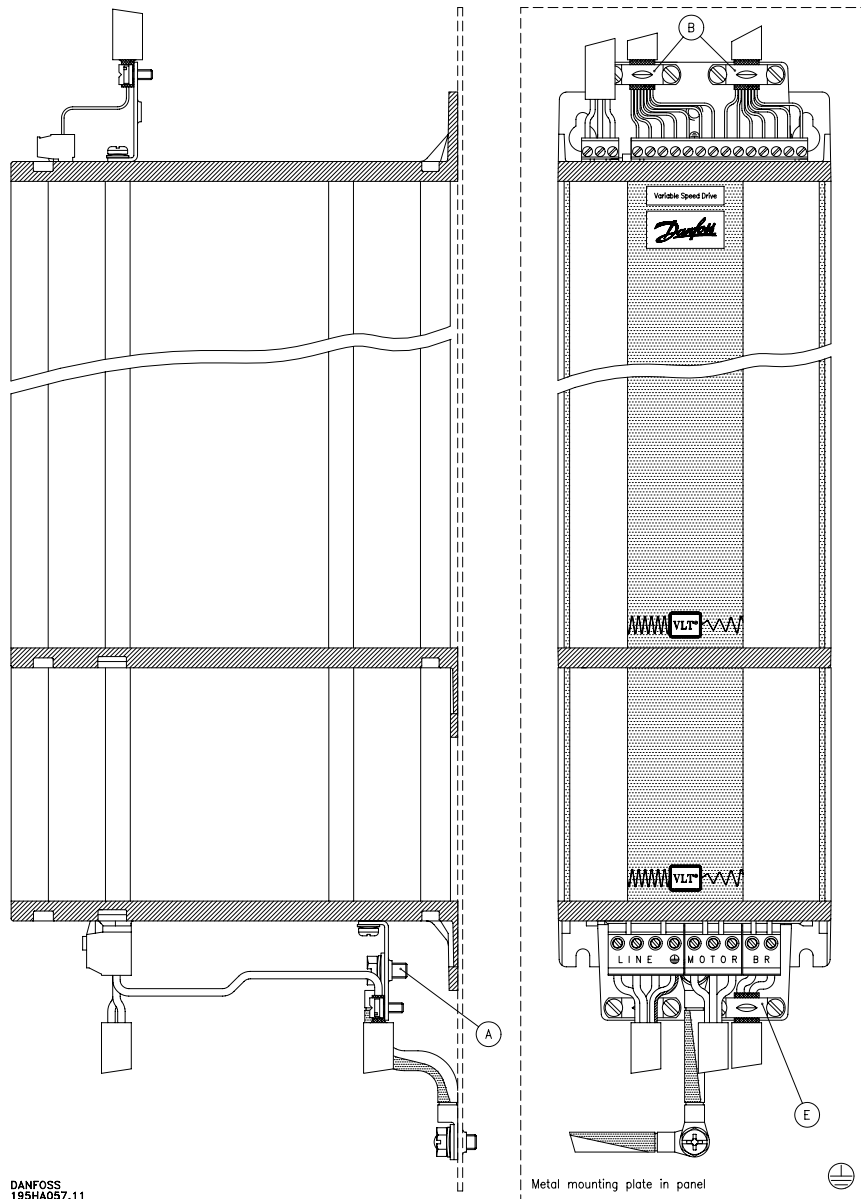

DANFOSS
155HAGS7.11

*) VLT 2060 Max. 415 V

■ For further information

When you have finished installing the VLT frequency converter, see the section [After installation](#) for information about how to operate the VLT frequency

converter. You will also get information about what parameters to choose to ensure optimum operation.

■ Installation guide

Following this installation guide the VLT® 2000 units with built-in compact RFI filter comply with the EMC requirements according to EN 55011 group 1A.

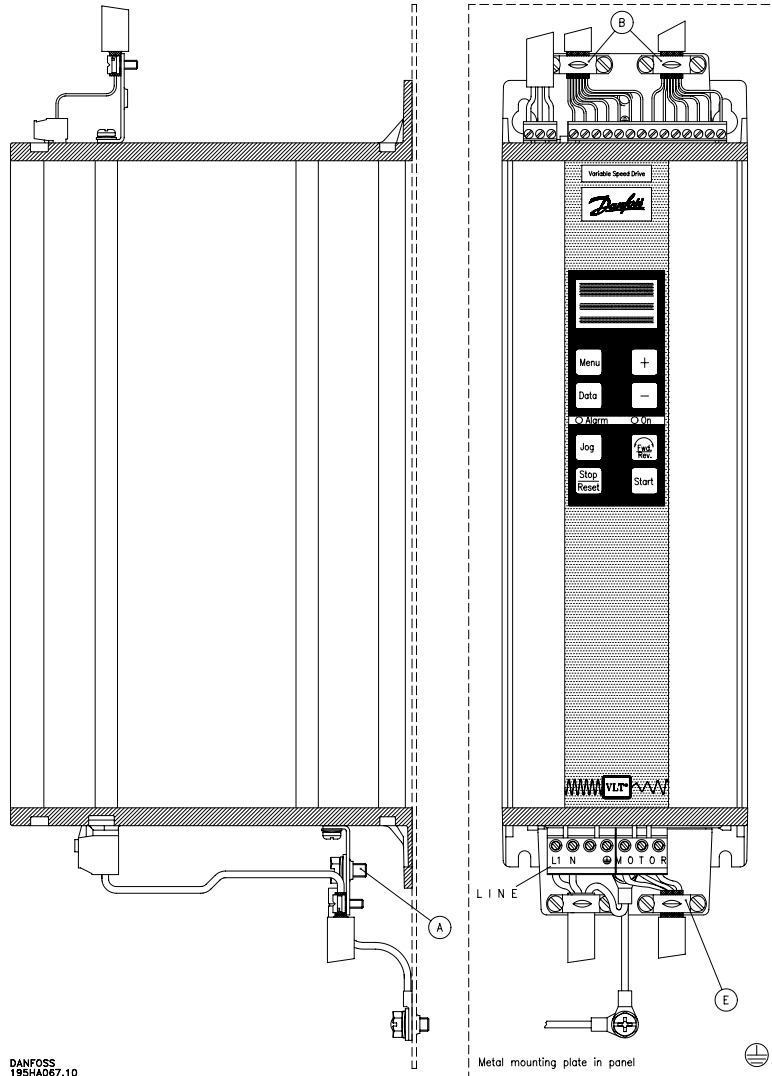

DANFOSS
195HA067.10

■ Technical data

The technical data on this page only apply to VLT® 2010, 0.37 kW, VLT® 2015, 0.55 kW and VLT® 2020, 0.75 kW with built in compact RFI filter.

Cable type: Screened
 Max. length: 20 m
 Mains supply: 1 x 220-240 V

Clamp to secure cables and cable screen type 195H6129 is delivered with the above units.

Mains supply connection:

Cable is secured in cable relief fitting.
 Earth wire is secured in the earth screw on the frequency converter.

Motor cable connection:

Motor cable and screen is secured in cable relief fitting and the wires are connected in the motor plug.

Chapter 1

- Quick Setup,
If you are familiar with a VLT Page 14
- Quick Setup,
If you are not familiar with a VLT Page 14
- A simple connection example Page 14
- How to program Page 15
- Survey of terminals Page 16
- Description of connection terminals Page 16
- How to check connection of
control cables Page 17
- Prefuses Page 17
- Cables Page 17
- Check grounding Page 17
- Commissioning and testing Page 18
- Basic settings Page 18

■ Quick Setup

If you are familiar with a VLT

If you know the VLT and how to move round in the menus and parameters, you can go directly to steps 1-9 overleaf to get started.

■ Quick Set

If you are not familiar with a VLT

If you have never operated a VLT frequency converter before, you can learn it on the basis of the instructions on page 15.

■ A simple connection example

In the figure below you can see a simple connection example based on the Quick Setup programming overleaf.

Connection example

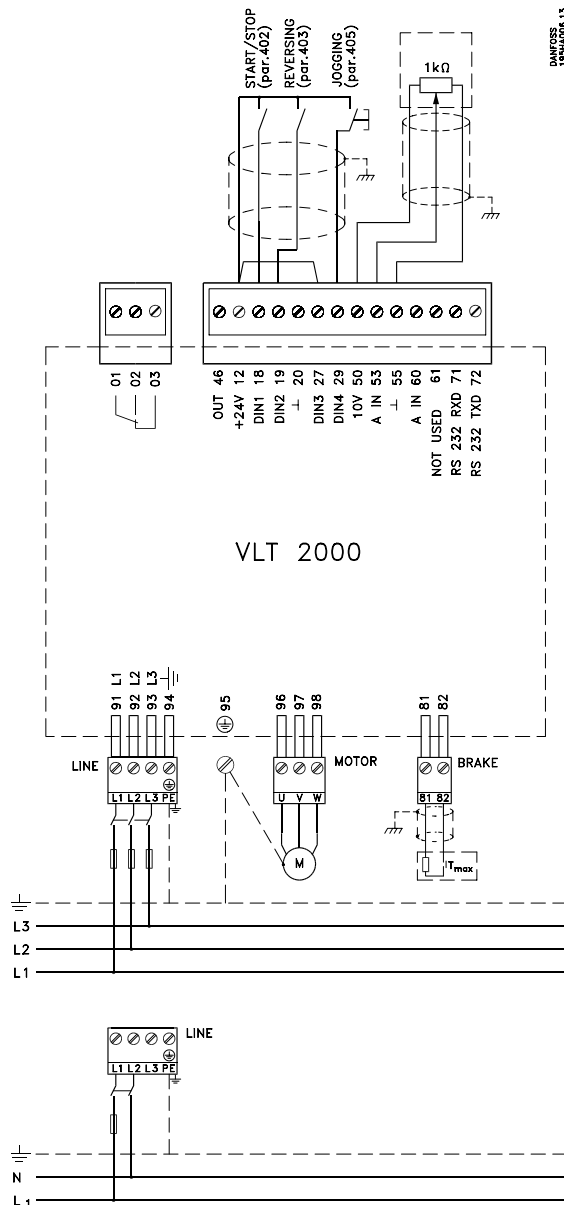

■ How to program

The Quick Setup shown is based on the assumption that you want your VLT to operate with the following setup:

1. External start/stop
2. Potentiometer connected for external speed control
3. Option to change rotation direction
4. Option to select a fixed speed (Jog)



If you use a brake module, you must program one parameter more, and two more if you want local operation via the display keys.

This will appear from the two tables at the bottom.
To store the data press the “menu” key!

When you have connected your VLT, as described on the previous page, you must program a few parameters.

Perform steps 1-9 for Quick Setup.

Standard motor with constant torque load without brake module on the frequency converter

Step	Parameter	Designation	Settings	Display indication
1	000	Language	Choose <i>English</i>	ENGLISH
2	103	Motor power	Read motor plate	
3	104	Motor voltage	Read motor plate	
4	105	Motor frequency	Read motor plate	
5	201	Min. frequency	Set wanted frequency	
6	202	Max. frequency	Set wanted frequency	
7	215	Ramp up 1	Set wanted ramping time	
8	216	Ramp down 1	Set wanted ramping time	
9		Start the frequency converter	This is done by supplying terminals 18 and 27 with 24 V DC from the frequency converter's terminal 12 or by using an external 24 V DC voltage	

If a brake module is mounted, make the following settings

Step	Parameter	Designation	Settings	Display indication
1	300	Brake function	If a brake module is used, choose <i>Applied</i>	APPLIED
2		Start the frequency converter	This is done by supplying terminals 18 and 27 with 24 V DC from the frequency converter's terminal 12, or by using an external 24 V DC voltage	

If you want local operation and start, make the following settings

Step	Parameter	Designation	Settings	Display indication
1	003	Operation site	Choose <i>Local</i>	LOCAL
2	004	Local reference	Record wanted output frequency by means of the “+” and “-” keys	

■ Survey of terminals

Below you will see a survey of all the terminals of a VLT frequency converter (3 x 380-460 V).

The control signals and the terminals for the brake module are described at the bottom of this page.

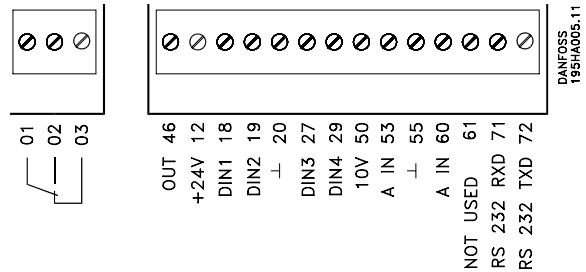
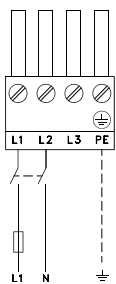
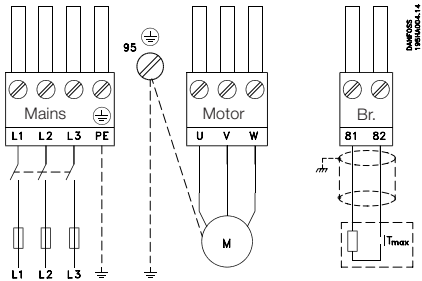

■ Description of connection terminals

Terminal 12: Internal voltage supply

24 V DC activates digital inputs such as Start/stop, Jog or Quick stop.

Terminal 18: Start/stop (Digital input)

When 24 V DC is applied the motor starts on condition that

- digital input 27 (Quick stop) is connected to 24 V DC.
- you have made no local stop command ("Stop/reset" key).
- f_{max} is > 0 Hz.
- a reference signal has been given (see para. 402).

Terminal 19: Reversing (Digital input)

When 24 V DC is applied to terminal 19, the motor starts reversing, either at once or after a stop command. If you have chosen *pulse start* in para. 402 (terminal 18), the start reversing function of para. 403 is automatically a pulse-activated function.

Terminal 20: Digital common

This terminal is the reference for all digital signals, including bus.

Terminal 27: Stop (Digital input)

When you apply 0 V you can give different stop signals. See also para. 404.

Terminal 29: Jogging (Digital input)

This terminal allows you to activate a fixed preprogrammed speed. See para. 405.

Terminal 46: Output

Using parameter 408 you can choose between different output signals. The output is an open collector output, and a pull-up resistor of min. 600 ohm must therefore be connected to terminal 12 (+24 V).

Terminal 50: Internal voltage supply

With 10 V DC voltage you can set an analogue control signal using a 1 kohm potentiometer with terminal 55 as reference.

Terminal 53: Analogue control voltage

Using parameter 412 you can choose between 0 - +10 V DC or +10 - 0 V DC analogue voltage. The terminal is used together with terminals 50 and 55. The voltage value determines the output frequency and thus also the speed of the motor.

Terminal 55: Analogue common

Is used together with terminals 50 and 53 or together with terminal 60.

Terminal 60: Analogue control current

Using parameter 413 you can choose between four different input signals:

0-20 mA, 4-20 mA, 20-0 mA or 20-4 mA.

The current value determines the output frequency.

Terminal 61: Not used

Terminals 71-72: RS 232 port

Connect the terminals to a PC, if you want to control the VLT frequency converter via PC software. Terminal 20 acts as digital common.

Terminals 81-82: Brake resistor

By means of these terminals you can connect the brake resistor on units with brake function.

Note the live voltage 550 V DC.

■ How to check connection of control cables

The VLT frequency converter must be connected so that it is possible to control it via the different signal inputs at the top of the enclosure.

Terminals 01-03:	Relay output	Max. 250 V, max. 2 A. Relay: Not activated
Terminal 12:	Supply to digital inputs	24 V DC, max. 140 mA
Terminals 18-19: 27-29	Digital inputs	0-24 V, $R_i=2$ kohm (max. 37 V for 10 sec.) (min. on-time 80 ms.)
Terminal 46:	Digital output signal (open collector)	Max. 24 V DC, max. 40 mA, min. 600 ohm
Terminal 50:	Supply to 1 kohm potentiometer	10 V DC, max. 12 mA
Terminal 53	Analogue control voltage	+0 - 10 V DC, $R_i=10$ kohm, +10 - 0 V
Terminal 60:	Analogue control current	0/4-20 mA, $R_i=226$ ohm, 20-0/4 mA
Terminals 71/72:	RS 232 standard bus	71 RXD, 72 TXD, 20 dig. ref.
Terminals 81/82:	Used in connection with brake resistor	
Terminal 20:	Digital common	Must be used as reference for all digital signals
Terminal 55:	Analogue common	Must be used as reference for all analogue signals.

■ Prefuses

Prefuses must be installed in the mains supply to the frequency converter.

(Max. sizes)

Mains supply 1/3 x 208/220/230/240 V						Mains supply 3 x 380-460 V					
2010	2015	2020	2030	2040	2050	2020	2025	2030	2040	2050	2060*
10 A	16 A	20 A	20 A	20 A	25 A	16 A	16 A	16 A	16 A	16 A	20 A

■ Cables

The cables to control signals and brake resistor must be screened. It is recommended to use unscreened motor cable.

If you use screened cables, the screen must be connected to the screen termination bracket of the VLT frequency converter and brake resistor.

Motor/mains cables (max. cable cross-section)

Mains supply 1/ 3 x 208/220/230/240 V						Mains supply 3 x 380-460 V					
2010	2015	2020	2030	2040	2050	2020	2025	2030	2040	2050	2060*
4 mm ² for all VLT 2000 Series types						4 mm ² for all VLT 2000 Series types					

Control cables (max. cable cross-section)

Mains supply 1/ 3 x 208//220/230/240 V						Mains supply 3 x 380-460 V					
2010	2015	2020	2030	2040	2050	2020	2025	2030	2040	2050	2060*
1.5 mm ² for all VLT 2000 Series types						1.5 mm ² for all VLT 2000 Series types					

*) VLT 2060: Max. 415V

■ How to check the grounding

The grounded line must be connected to terminal 94 (PE). If you use a thick cable this must be connected to the 6 mm large screw (terminal 95) in the bottom of the VLT frequency converter.

■ Commissioning and testing

When the VLT frequency converter has been connected to control signals, you may want to test the system.

This following test is not suitable if you use the built-in PI controller.

1. Disconnect the motor from the VLT frequency converter.
2. Connect the VLT frequency converter to the mains.
3. Make the necessary settings such as min./max. frequency and connect the necessary control signals, possibly via PLC.



As a minimum you must set the parameters and connect the control signals as described in chapter 1, Quick Setup.

4. Make a simulation without motor:
 - a) Give a start signal via a contact to terminal 18.

Example of display indication:



- b) The speed (frequency) can be changed by means of the potentiometer connected.

Example of display indication:

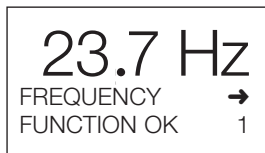

- c) Make a quick stop by means of disconnecting between terminal 27 and terminal 12.

Example of display indication:



During the simulation you can see that the VLT frequency converter reacts by watching the display indications.



If no external control has been connected, you can choose to simulate the function of the VLT frequency converter locally via the keyboard. See description at the bottom of page 31.

5. Press the “Stop” key to stop the VLT frequency converter before you connect the motor.
6. Test the whole system (repeat steps 4 and 5) with the motor connected to check the direction of rotation.

■ Basic settings

The VLT frequency converter has been preset from the factory so that normally it will function after a few data values are recorded/changed.

See Quick Setup on page 15.



The factory settings of the VLT frequency converter are listed on page 105.

Chapter 1	■ How the VLT works Page 21 Technology
Chapter 2	■ How to size your VLT Page 29 Product range, sizing, technical data
Chapter 3	■ How to install your VLT Page 41 The connection terminals, dimensions, mechanical installation, electrical installation, and motor connection
Chapter 4	■ How to operate your VLT Page 45 The control panel and the structure of the menus
Chapter 5	■ The control possibilities of the VLT Page 51 The menu groups and the various parameters
Chapter 6	■ Description of parameters Page 59
Chapter 7	■ Display messages Page 81 Status, alarm and warning and reset messages
Chapter 8	■ Special conditions Page 85 CE-labelling EMC, extreme operational conditions, electrical noise, air humidity, efficiency and du/dt measurements
Chapter 9	■ Factory settings and service Page 97 Factory settings and fault location Form to note down the VLT parameter settings
Chapter 10	■ Subject index Page 107

Chapter 1

- How the VLT is built up Page 22
- The Danfoss VVC principle Page 23
- Factory-programmed optimization Page 24
- Control accuracy Page 25
- Protection against mains disturbance Page 25
- Galvanic isolation Page 25
- Advanced motor protection Page 25
- Long motor cables Page 25
- Functional diagrams Page 26

How the VLT is built up

A frequency converter is an electronic unit for infinite speed control of a.c. motors. The frequency converter controls the motor speed by converting the fixed voltage and frequency of the supply mains, e.g. 400 V/ 50 Hz, to variable values. The frequency converter does this by rectifying a.c. voltage to DC voltage and converting this to a.c. voltage with variable amplitude and frequency.

The variable voltage and frequency supplying the motor make infinite speed control of standard three-phase, asynchronous motors possible. Today the a.c. motor controlled by a frequency converter is a natural part of all automatised plants. Apart from utilizing the good features of the a.c. motor, the infinite speed control gives the user a multitude of additional advantages:

Saved energy

Energy is saved when the motor runs at a speed which is continually matched to the momentary requirement. An example is a pump and ventilating plant, where a frequency converter can reduce energy consumption by the cube of the speed.

Improved process

Matching the speed to the production process has several advantages: an increase in production and a decrease in the consumption of materials and the scrapping rate.

Improved quality

The number of starts and stops is reduced. This avoids unnecessarily hard treatment of machine parts.

Less maintenance

The frequency converter requires no maintenance. In water supply plants there are no pressure surges which might damage the water pipes.

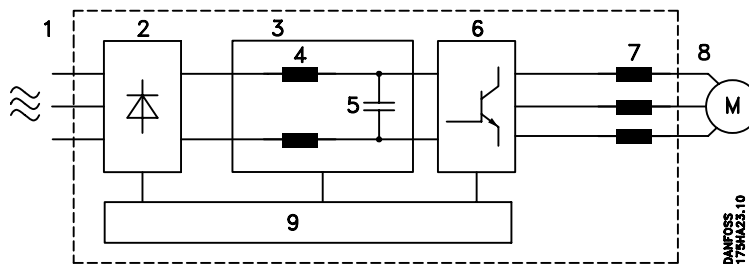
1. Mains supply

- 1 × 220/230/240 V AC, 50/60 Hz
- 3 × 208/220/230/240 V AC, 50/60 Hz
- 3 × 380/400/415/440/460 V AC, 50/60 Hz

2. Rectifier

Three-phase rectifier bridge rectifies AC to DC.

3. Intermediate circuit

DC voltage = $\sqrt{2}$ × supply voltage

4. Coils in the intermediate circuit
(not all VLT 2000 units)

Smoothen DC voltage and limit mains supply interference (mains harmonics).

5. Capacitors in the intermediate circuit

Smoothen the voltage of the intermediate circuit (energy store).

6. Inverter

Converts DC voltage to variable a.c. voltage and variable frequency.

7. Motor coils (as module)

Advantages of motor coils:

- You can use long motor cables.
- Unlimited switching at the output of the frequency converter (trip may occur).

8. Output

Variable a.c. voltage, 10-100% of the supply voltage.
Variable frequency: 0-120/0-500 Hz.

9. Control card

The integrated computer controls the inverter, which generates the pulse pattern by means of which DC voltage is converted to variable a.c. voltage and variable frequency.

■ The Danfoss VVC principle

VLT 2000 Series frequency converters use an inverter control system known as the Voltage Vector Control (VVC) developed by Danfoss.

The VVC principle is superior to the traditional PWM (Pulse Width Modulation) principle used in most modern frequency converters in the following ways:

- Full-rated motor voltage at rated motor frequency.
- Near perfect resemblance to the sinusoidal mains supply.
- Extremely low switching losses, resulting in high converter efficiency.

The features are obtained through a special switching pattern: the switching intervals are very short, which means high switching frequency, and the six semiconductors of the inverter section are alternately

held inactive in pairs, throughout a 60° sine period. The current wave form of the motor current closely resembles that obtained on mains operation. The switching pause in 60° of the sine period also means that full-rated motor voltage can be obtained - and inverter switching losses are reduced by about one third.

The figures below show the switching pattern and maximum motor voltage according to the VVC principle and the traditional PWM principle respectively.

The full-rated motor voltage and the perfect current wave form mean that the Danfoss VLT 2000 Series allows full motor performance without any derating - just like running the motor on the mains.

Motor voltage and simplified switching pattern according to the Danfoss VVC principle

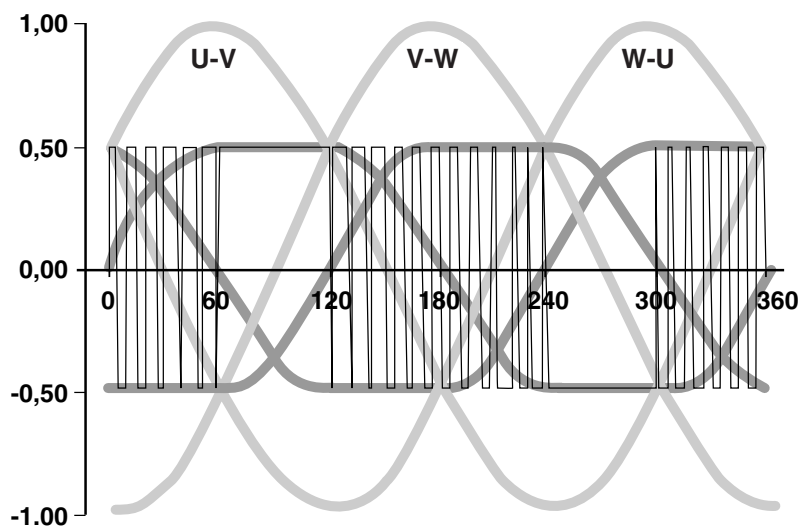

Motor voltage and simplified switching pattern according to the traditional PWM principle

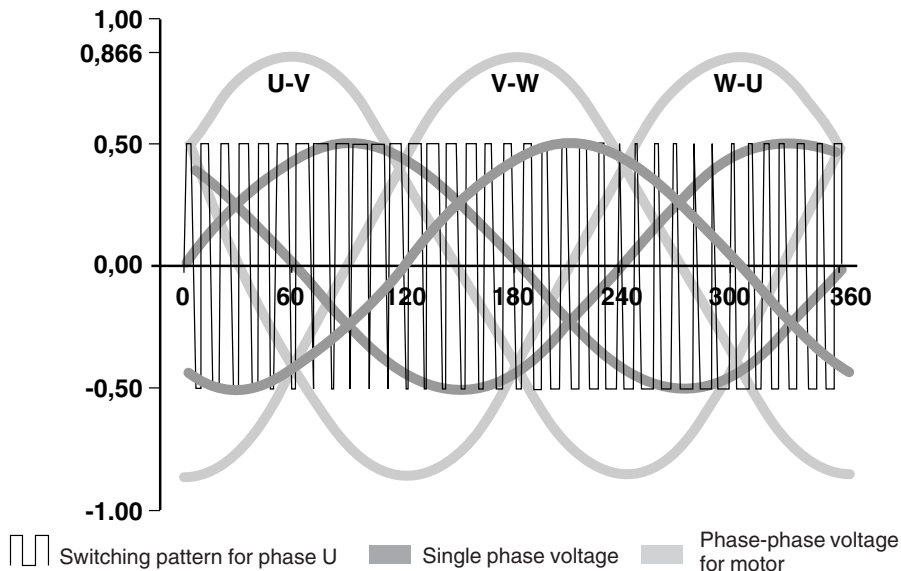

■ Factory-programmed optimization



VLT Series 2000 has dynamic adaptation of the motor voltage and frequency. This ensures correct magnetisation of the motor, thus providing optimum dynamics, accuracy or efficiency.

VLT has been designed for operation of the most common types of motors and loads.

Once parameters 103,104, 105, 107 and 108 have been set according to the motor type plate, your motor operation will be optimum in most cases.

Individual adaptation of VLT and motor is done via parameters 109-112.

Start voltage

increases the motor voltage at a given frequency. This increases the motor magnetization. The motor can yield a higher torque, but the disadvantage is that the motor losses are increased too. The result is a higher motor temperature. Excessive start voltage can cause a trip (cut-out).

Start compensation

changes the motor voltage as a function of the load. The voltage will increase with higher motor current. Over-compensation will overheat the motor and give the risk of instability and can cause trip (cut-out). As the name indicates, the function is most effective at low motor speed.

U/f ratio

This describes the pre-programmed U/f characteristics which indicate the relation between motor voltage (U) and frequency (f).

The U/f ratio can be adjusted to ensure correct excitation of the motor, thereby helping to obtain optimal dynamism, accuracy or efficiency.

Slip compensation

adds both frequency and voltage and compensates for the varying slip at varying load so that the motor speed is kept constant at varying load. Over-compensation may make the speed increase at increasing load. This means motor overload and risk of unstable motor operation.

Constant torque CT

- Par. 104 = Rated motor voltage
- Par. 105 = Rated motor frequency
- Par. 107 = Rated motor current
- Par. 108 = Motor no-load current
- Par. 109 = Start voltage
- Par. 110 = Start compensation
- Par. 111 = U/f ratio
- Par. 112 = Slip compensation

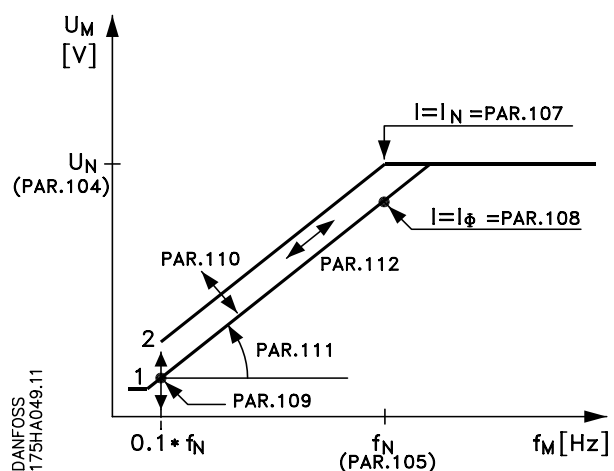

■ Control accuracy

Basically we distinguish between open loop and closed loop control. When the control is an open loop type the motor current acts as process feedback. The final result is therefore highly dependent on the characteristics of the motor.

Note that large motors give a better result than small motors.

A closed loop control incorporates a direct process feedback, which substantially improves the control accuracy.

The stated maximum torque follows the power hyperbola in the frequency range across the motor's rated frequency.

Open loop (depending on motor size)	±2.0 %	3-100 Hz (10-90% of max. torque)
PI (closed loop)	±0.5%	1.2-100 Hz (-90 - +90% of max. torque)

■ Programmable control inputs and signal outputs in 2 setups

The digital technique used in the VLT 2000 Series makes it possible to redefine the different control inputs and signal outputs and to program 2 different user defined setups.

It is easy for the user to program the required functions on the keyboard of the VLT 2000 Series or via the RS 232 user interface.

■ Galvanic isolation

With the VLT 2000 Series safety isolation is standard, as the high-voltage parts of the power section are galvanically isolated from the low-voltage parts of the control section according to VDE 0160/0106 (PELV). Therefore PCs and the like will not be disturbed.

■ Protection against mains disturbance

The VLT 2000 Series is protected against transients arising on the mains, e.g. when you switch in power factor phase-correction capacitors or when the supply is subject to lightning strikes.

Adequate motor voltage and full torque can be maintained down to 10% under-voltage on the supply mains.

■ Advanced motor protection

The VLT 2000 Series has a built-in electronic thermal motor protection. The frequency converter calculates the motor temperature on the basis of voltage, current, frequency and time.

The thermal motor protection is comparable with a thermal relay in the motor cables. Therefore it is superior to the traditional bi-metallic protection, where the altered cooling conditions due to the speed control are not taken into consideration.

■ Long motor cables

For the VLT 2000 Series motor coils in an IP 00 or IP 10 enclosure are available as modules.

This makes it possible to install a long cable between motor and frequency converter.

Motor coils are also included in the RFI and motor filter module in IP 20 enclosure. See page 34 for a specification of maximum cable length.

How the VLT works ■ Functional diagram VLT 2010-2030 single-phase/three-phase 208-240 V

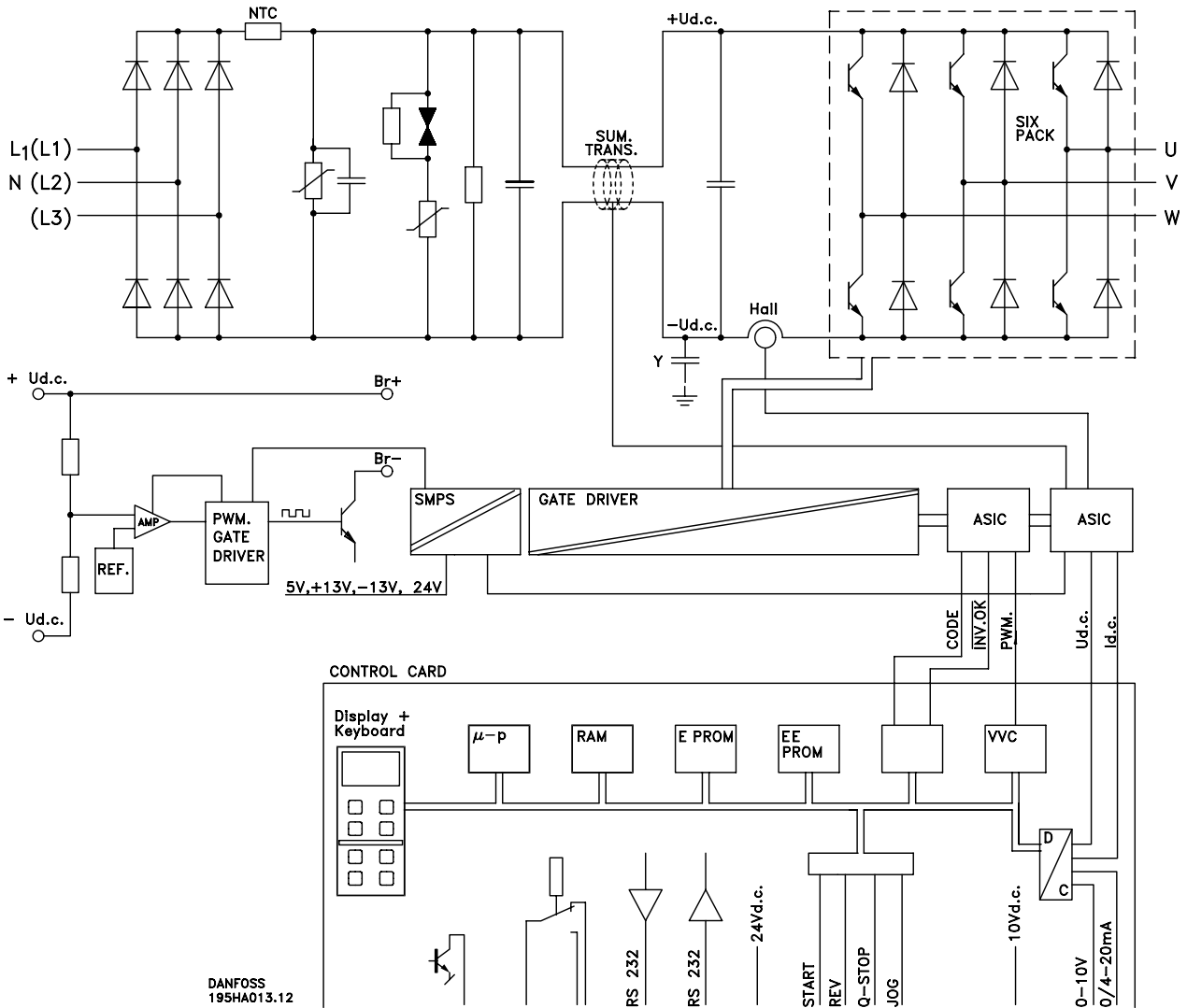

■ Function diagram VLT 2040-2050, 3-phase 208-240 V

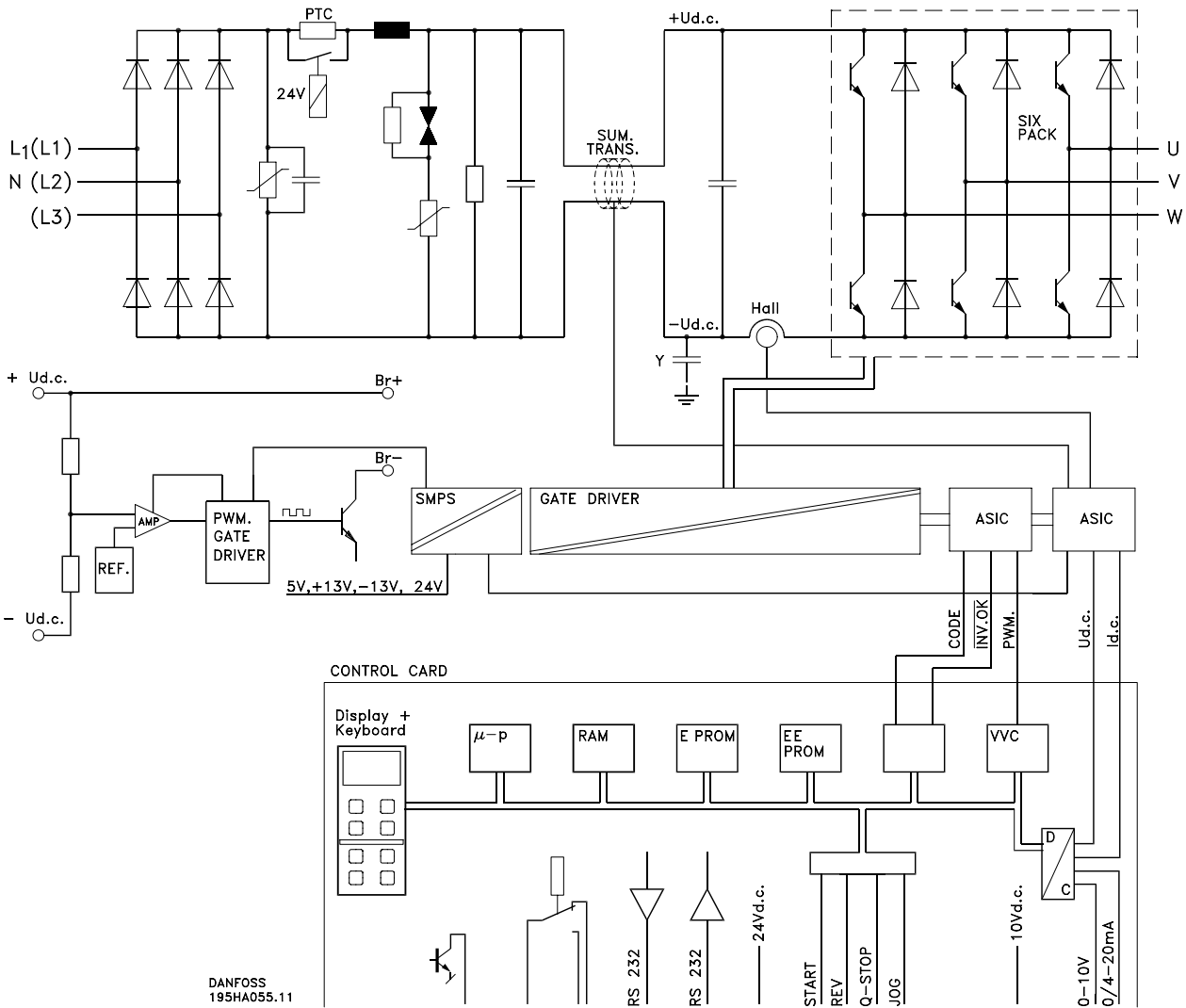

How the VLT works

■ Functional diagram VLT 2020-2060 three-phase 380-460 V

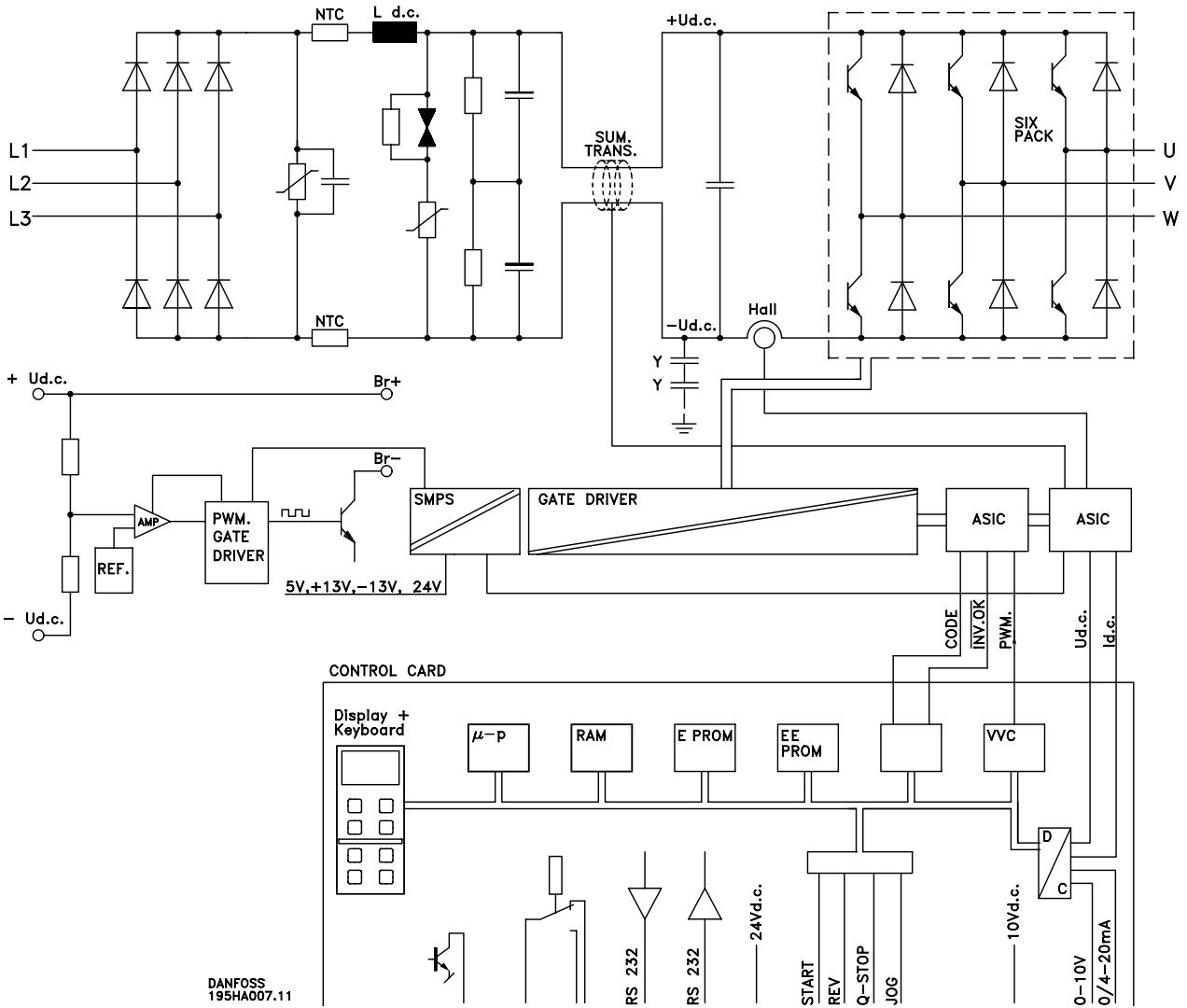

Chapter 2

- Selection of frequency converter Page 30
- Sizing Page 30
- Product range Page 31
- Brake function Page 33
- Motor coils (module) Page 34
- RFI and motor filter (module) Page 34
- LC and RFI filter (module) Page 34
- Dimensions Page 35
- Technical data Page 38

■ Selection of frequency converter

Usually the size of frequency converter is chosen on the basis of the shaft output, as this may be the only value known. However, if the data are known for both the application, the motor and the frequency converter, it is recommended to make a more accurate sizing.

The values must be based on the rated motor speed.



VLT 2000 only operates according to the CT (constant torque) characteristic

■ Sizing when you know the motor current

Exercise

Conveyor plant with a 1.1 kW, 3 × 380 V motor. At continuous operation the motor current is 2.5 A (3 × 415 V).

Solution

From the table on the next page you can see that a VLT type 2025 can yield 2.8 A at continuous operation. The right solution is therefore VLT 2025.

■ Sizing on the basis of the apparent power S_M [kVA] consumed by the motor

Exercise

A motor must yield constant torque at continuous operation. Usually the necessary values will appear from the motor plate or from the motor catalogue.

Solution

From the table on the next page you can see that VLT type 2025 can yield 2.0 kVA (415 V) at continuous operation. The solution is therefore VLT type 2025.

Read values

Motor current = 2.5 A (3 × 415 V)

$$\begin{aligned} S_M &= \frac{U \times I \times \sqrt{3}}{1000} \quad [\text{kVA}] \\ &= \frac{415 \times 2.5 \times \sqrt{3}}{1000} \quad [\text{kVA}] \\ &= 1.8 \text{ kVA} \end{aligned}$$

■ Sizing on the basis of the power requirement P_{VLT} [kW] of the motor

Exercise

A machine tool is driven by a 3 kW motor. The power requirement is indicated to be 2.4 kW. The motor efficiency η is 0.80, $\cos \varphi = 0.81$ and the motor voltage is 3 × 415 V.

η and $\cos \varphi$ are measured at 3 kW output. We estimate η and $\cos \varphi$ to be approximately the same at 80 % load.

Solution

From the table on the next page you can see that VLT type 2040 can yield 4.0 kVA (415 V) at continuous operation. The right solution is therefore VLT type 2040.

$$\begin{aligned} S_{VLT} &= \frac{P_m}{\eta \times \cos \varphi} \\ &= \frac{2.4 \text{ kW}}{0.80 \times 0.81} \\ &= 3.7 \text{ kVA} \end{aligned}$$

■ Which one to choose?

Mains: 1 × 220/230/240 V, 3 × 208/220/230/240 V

VLT type	Typical shaft output [kW]	Constant output current $I_{VLT,N}$ [A]	Constant output power at 230 V [kVA]
2010	0.37	2.2	0.9
2015	0.55	3.1	1.3
2020	0.75	4.0	1.6
2030	1.5	7.5	3.1
2040 *)	2.2	10.6	4.4
2050 *)	3.0	16.7	6.9

*) VLT types 2040 and 2050: only three-phase mains supply.

*Mains: 3 × 380/400/415/440/460 V *)*

VLT type	Typical shaft output [kW]	Constant output current $I_{VLT,N}$ [A]	Constant output power at 415 V [kVA]
2020	0.75	2.4	1.7
2025	1.1	2.8	2.0
2030	1.5	4.0	2.9
2040	2.2	5.6	4.0
2050	3.0	7.6	5.5
2060 *)	4.0	9.7	7.0

*) VLT type 2060: 3 × 380/400/415 V

■ Product range

The VLT 2000 Series is available in a single-phase/three-phase version (1 x 220-240 V or 3 x 208-240V) in the power range 0.37-1.5 kW and a three-phase version (3 x 208-240 V) in the power range 2.2-3.0 kW. A three-phase version (3 x 380-460 V) in the power range 0.75-4.0 kW is also available.



All units are delivered in an IP 20 enclosure.

■ How to find the right code number

When you have found the right VLT size you can find the code number to be ordered in the table below.

Example:

VLT type 2020 (3 x 380-460 V) three-phase without display with brake has the code number 195H3400.

As appears from the table a VLT 2000 single/three phase can be delivered with various options and modules such as brake function, RFI filter and motor coils.

VLT 2000 Series, single-phase/three-phase (1 x 220-240 V / 3 x 208-240 V)					(3 x 208-240 V)	
	VLT 2010	VLT 2015	VLT 2020	VLT 2030	VLT 2040	VLT 2050
Without display	195H3100	195H3102	195H3104	195H3106	195H3108	195H3110
With display	195H3101	195H3103	195H3105	195H3107	195H3109	195H3111
Without display with brake	195H3200	195H3202	195H3204	195H3206	195H3208	195H3210
With display with brake	195H3201	195H3203	195H3205	195H3207	195H3209	195H3211
RFI and motor filter module IP 20 1-phase	195H6523	195H6524	195H6524	195H6525		
RFI and motor filter module IP 20 3-phase	195H6522	195H6522	195H6522	195H6522		
RFI-filtermodul IP 20 (VBG-4)*	-	-	-	-	195H6528	195H6528
Motor coil module IP 00	195H6510	195H6510	195H6510	195H6510		
Motor coil module IP 10 (VBG-4)	195H6521	195H6521	195H6521	195H6521		
LC and RFI filter module IP 20 3-phase	195H6527	195H6526	195H6526	195H6526		

* Schaffner RFI-filter type FN351 - 16/29

VLT 2000 Series, three-phase (3 x 380/460 V). Note: VLT 2060: 380/415 V

	VLT 2020	VLT 2025	VLT 2030	VLT 2040	VLT 2050	VLT 2060
Without display	195H3300	195H3302	195H3304	195H3306	195H3308	195H3310
With display	195H3301	195H3303	195H3305	195H3307	195H3309	195H3311
Without display with brake	195H3400	195H3402	195H3404	195H3406	195H3408	195H3410
With display with brake	195H3401	195H3403	195H3405	195H3407	195H3409	195H3411
RFI and motor filter module IP 20**	195H6522	195H6522	195H6522	195H6522	195H6522	195H6522
Motor coil module IP 10 (VBG-4)	195H6521	195H6521	195H6521	195H6521	195H6521	195H6521
LC and RFI filter module IP 20**	195H6527	195H6527	195H6527	195H6526	195H6526	195H6526

**Only 380/415 V

■ VLT 2000 Series built-in RFI filter EN 55011 1A:

VLT Series 2000, single-phase (1 x 220-240 V)

	VLT 2010	VLT 2015	VLT 2020	VLT 2030
Without display	195H3600	195H3602	195H3604	195H3606
With display	195H3601	195H3603	195H3605	195H3607
Without display / With brake	195H3700	195H3702	195H3704	195H3706
With display / with brake	195H3701	195H3703	195H3705	195H3707
Motor coils, IP20, three-phase	195H6529	195H6529	195H6529	195H6529

VLT Series 2000, three-phase (3 x 380-415 V)

	VLT 2020	VLT2025	VLT2030	VLT 2040	VLT 2050	VLT 2060
Without display	195H3800	195H3802	195H3804	195H3806	195H3808	195H3810
With display	195H3801	195H3803	195H3805	195H3807	195H3809	195H3811
Without display / With brake	195H3900	195H3902	195H3904	195H3906	195H3908	195H3910
With display / with brake	195H3901	195H3903	195H3905	195H3907	195H3909	195H3911
Motor coils, IP20, three-phase	195H6529	195H6529	195H6529	195H6529	195H6529	195H6529

The VLT® 2000 with built-in RFI filter in IP 20 enclosure, is designed to be built directly into control panels.

EMC demands are fulfilled without any extra component.

- RFI filter to reduce electromagnetic interference.
- The VLT® 2000 units meet all necessary EMC

- immunity standards as laid down in the IEC 1000-4.
- The VLT® 2000 units meet the EMC emission requirements as laid down in the EN 55011, Group 1 Class A. The EMC emission specifications are complied with by using up to 40 m unscreened cable, see page 88.

■ VLT 2000 Series built-in compact RFI filter

For technical data, see page 12.

VLT Series 2000, single-phase (1 x 220-240 V)

	VLT 2010	VLT 2015	VLT 2020
With display / without brake	195H3112	195H3113	195H3114

■ Accessories/options to the VLT Series 2000:

Remote control (option)	175H1788
PC program (VLS Dialog 2)(Danish)	175H2877
PC program (VLS Dialog 2)(English)	175H2850
PC program (VLS Dialog 2)(German)	175H2876

■ Brake function

All units can be delivered with built-in brake function (factory-mounted). The brake resistors for the brake function must be connected according to the connection diagram on page 42.

Specifications	VLT 2010-2030	VLT 2040-2050	VLT 2020-2050	VLT 2060
	208-240 V	208-240 V	380-460 V	380-415 V
Max. current	5.5 A	16 A	5.5 A	7.5 A
Min. brake voltage	372 V DC	372 V DC	747 V DC	646 V DC
Max. brake voltage	382 V DC	382 V DC	764 V DC	661 V DC
P-band	4 V	8 V	8 V	8 V
Overcurrent fuse	None	None	None	None
Min. brake resistance	70 Ohm	25 Ohm	140 Ohm	90 Ohm

■ Motor coils (module)

The IP 20 enclosure (also with mains filter) is available with integrated motor coils or as an IP 00/IP 10 module for external mounting.

Motor coils in IP 00 and IP 10 enclosure contain only one motor coil, making it possible to use long motor cables up to 300 m. These motor coils must be installed separately (not for co-building with the VLT frequency converter).

Technical data

	208-240 V/IP 20	208-240V/IP 00	380-415 V/IP 20	380-460 V/IP 10
Max. current	3 × 2.2/4.0/7.5 A	3 × 7.5 A	3 × 9.7 A	3 × 10 A
Max. cable length (unscreened)	150 m	300 m	150 m	300 m
Max. cable length to fulfill EN 55011, Group 1, Class A 100 m Unscreened	-	100 m	-	-
Max. cable length (screened)	75 m	150 m	75 m	150 m
Inductance 3x	75 µH	75 µH	120 µH	240 µH
Outside dimensions	100x110x180 mm	-	100x110x180 mm	-
Code no. 195H6521	195H6523,6524,6525		195H6510	195H6522

■ Additional literature:

- MI.20.CX.02 - Motor coil, IP 10
- MI.20.BX.52 - Motor coil, IP 00
- MD.65.BX.XX - Brake resistors

■ RFI and motor filter (module)

The RFI and motor filter module in IP 20 enclosure is designed to be built in with the VLT frequency converter itself. The filter contains the following:

- RFI filter to reduce electro-magnetic interference.
- Motor coils making it possible to use long motor cables.
- Motor filter (motor RFI filter) to reduce the electro-magnetic interference from the motor cable.

The VLT 2000 Series basic units meet EMC immunity requirements as laid down in the IEC 1000-4 standards, but do not meet any EMC emission requirements.

Equipped with the IP 20 RFI and motor filter (195H6522, 195H6523, 195H6524, 195H6525), the VLT 2000 Series meets the EN 55011, Group 1, Class A requirements of EMC emission. The EMC emission specifications are complied with by using up to 100 m unscreened motor cable.

■ LC and RFI filter (module)

The LC and RFI filter module in IP 20 enclosure is designed to be built in with the VLT frequency converter itself. The filter contains the following:

- RFI filter to reduce electro-magnetic interference
- LC filter to reduce the acoustic noise level from the motor and make it possible to use long motor cables up to 300 m.
- Motor filter (motor RFI filter) to reduce the electro-magnetic interference from the motor cable.

Equipped with the IP 20 LC and RFI filter (195H6526 and 195H6527), the VLT 2000 Series meets the EN 55011, Group 1, Class A requirements of EMC emission.

The EMC emission specifications are complied with by using up to 100 m unscreened motor cable.

Code nr.	195H6527	195H6526
VLT basic unit	VLT 2020, 2025, 2030	VLT 2040, 2050, 2060
Enclosure	IP 20	IP 20
Outside dimensions (H x W x D)	170 x 110 x 180 mm	170 x 110 x 180 mm
Built-in fan	Yes	No
Mains voltage	380 - 415 V	380 - 415 V
Current (max.)	4.0 A	9.7 A
Cut-out frequency	No limit	No limit
EMC immunity	IEC 801 Series	IEC 801 Series
EMC emission	EN 55011 Group 1, Class A	EN 55011 Group 1, Class A
Max. cable length to fulfill EN 55011, Group 1, Class A Unscreened	100 m	100 m
Max. temperature (full load)	40°C	40°C

■ Dimensions

VLT 2010-2030	single-phase, 220-240 V/three-phase, 208-240 V
VLT 2010-2020 built-in compact RFI filter	single-phase, 220-240 V

Min. space over and under frequency converters: 100 mm

Min. space to the left and the right of frequency converters: 0 mm (side-by-side mounting).

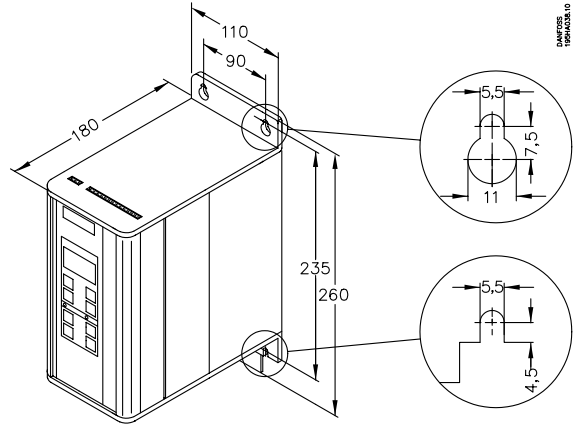

VLT 2010-2030 with module	single-phase, 220-240 V/three-phase, 208-240 V
---------------------------	--

With 100 mm module: A = 362 mm
a = 337 mm

With 170 mm module: A = 432 mm
a = 407 mm

Min. space over and under frequency converters: 100 mm.

Min. space to the left and the right of frequency converters: 0 mm (side-by-side mounting).

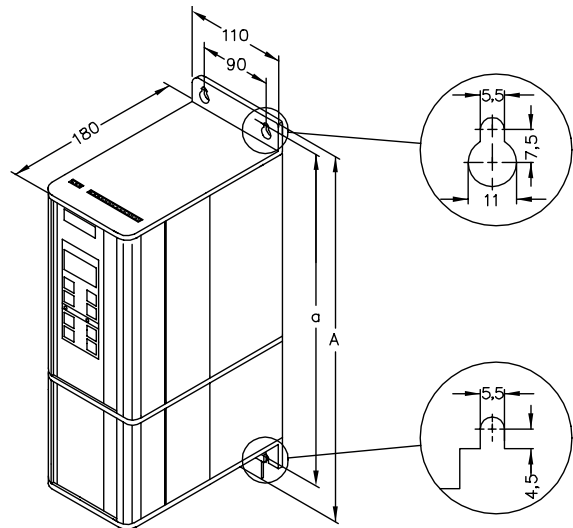

■ Dimensions (cont'd)

VLT 2020-2060
VLT 2040-2050

three-phase, 380-415/460 V
three-phase, 208-240 V

Min. space over and under frequency converters: 100 mm.

Min. space to the left and the right of frequency converters: 0 mm (side-by-side mounting)

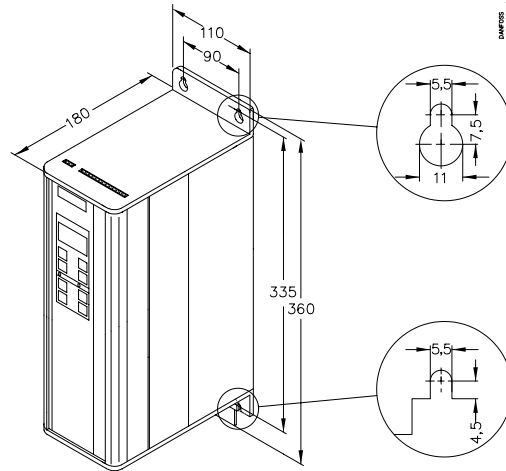

VLT 2020-2060 with module

three-phase, 380-415/460 V

with 100 mm module: A = 462 mm
a = 437 mm

With 170 mm module: A = 532 mm
a = 507 mm

Min. space over and under frequency converters: 100 mm.

Min. space to the left and the right of frequency converters: 0 mm (side-by-side mounting)

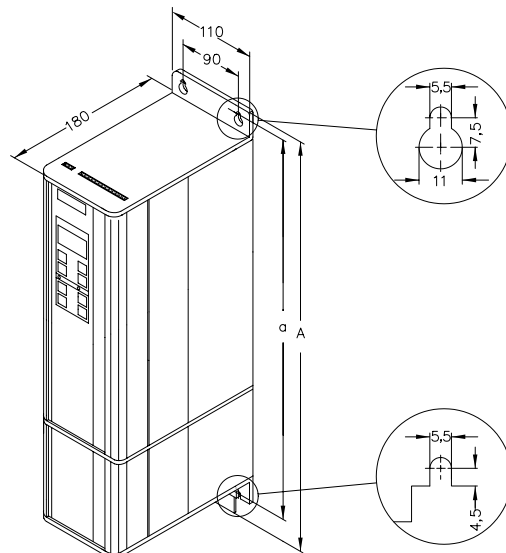

■ **Dimensions (cont'd)**

VLT 2010-2030 with built-in RFI filter, single-phase, 220-240 V

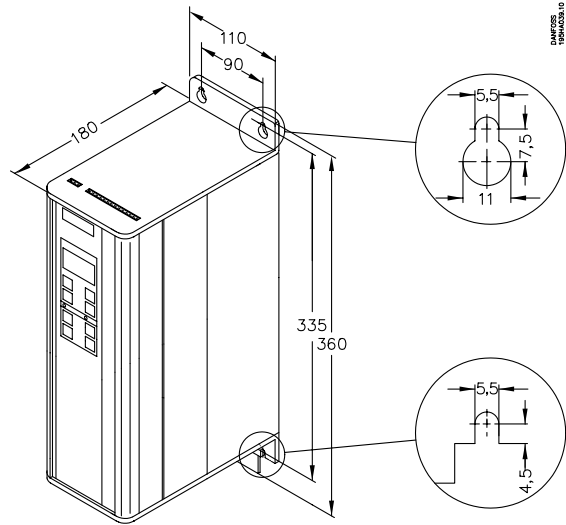

Min. space over and under frequency converters: 100 mm.

Min. space to the left and the right of frequency converters: 0 mm (side-by-side mounting)

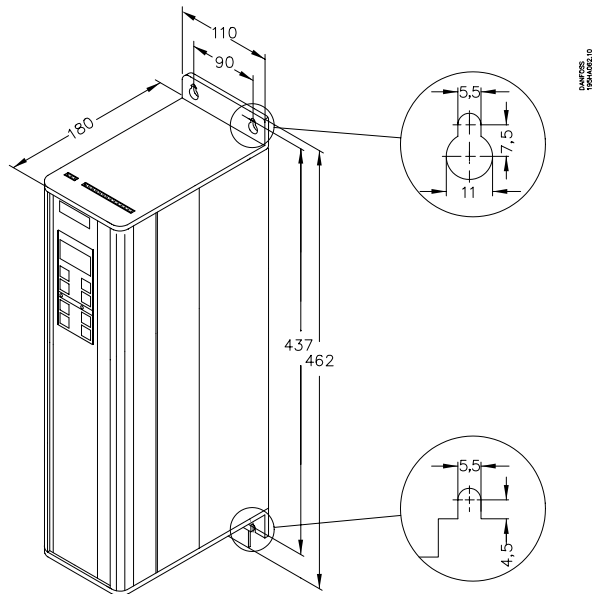

■ VLT 2020-2060 with built-in RFI filter, three-phase, 380-415 V



Min. space over and under frequency converters: 100 mm.

Min. space to the left and the right of frequency converters: 0 mm (side-by-side mounting)

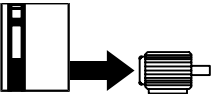
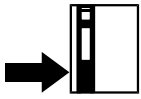
■ Technical data
Mains: 1 x 220/230/240 V, 3 x 208/220/230/240 V
3 x 208/220/230/240 V

Meets the international standards, UL/ cUL ⁴⁾		VLT type	2010	2015	2020	2030	2040	2050	
	Constant load (CT):								
	Output current	$I_{VLT,N}$ [A]	2.2	3.1	4.0	7.5	10.6	16.7	
		$I_{VLT,MAX}$ [A] (60 s)	3.5	4.9	6.3	10.5	17.0	26.7	
	Output	$S_{VLT,N}$ [kVA]	0.9	1.3	1.6	3.1	4.4	6.9	
		$S_{VLT,MAX}$ [kVA] (60 s)	1.4	2.1	2.6	4.3	7.0	11.0	
	Typical shaft output	$P_{VLT,N}$ [kW]	0.37	0.55	0.75	1.5	2.2	3.0	
	Max. cable cross section	[mm ²]	4	4	4	4	4	4	
	Max. motor cable length	[m]	40 (with motor coils IP 10: unscreened cables 300 m, screened cables 150 m)						
	Output voltage	U_M [%]	0-100% of mains voltage						
	Output frequency	f_M [Hz]	0-120 or 0-500; programmable						
Rated motor voltage	$U_{M,N}$ [V]	200/208/220/230/240							
Rated motor frequency	$f_{M,N}$ [Hz]	50/60/87/100							
Thermal motor protection during operation		Built-in thermal motor protection (electronic)							
Switching on the output		Unlimited (frequent switching may cause cut-out)							
Ramp times	[s]	0.1-800							
		VLT type	2010	2015	2020	2030	2040	2050	
	Max. input current	$I_{L,N}$ [A]	(5.3/3.5)	(8.5/5.6)	(10.6/7.1)	(18/12)	(-/10)	(-/16)	
	Max. cable cross section	[mm ²]	4	4	4	4	4	4	
	Max. prefuses	[A]	10	16	20	20	20	25	
	Bussmann Fuse type KTN-R 250 V AC ⁵⁾	[A]	10	15	20	20	20	25	
	Mains supply voltage	[V]	1 x 220/230/240 ±10 %				3 x 208/220/ 3 x 208/220/230/240 ±10 %		
	Mains supply frequency	[Hz]	50/60						
	Power factor/cos. ϕ_1		Without mains filter:0.50/0.87				0.90/1.0		
			With mains filter:0.65/1.0				0.90/1.0		
	Efficiency		>0.94 at rated load						
	Switching on the input	times/min.	5						
		VLT type	2010	2015	2020	2030	2040	2050	
	Weight [kg]	IP 20	2.0	2.0	2.1	2.1	4.6	4.6	
	Weight [kg] with built-in RFI filter	IP 20	3.7	3.7	3.8	3.8			
	Power loss at max. load	CT [W]	39	53	69	126	136	236	
	Enclosure		IP 20	IP 20	IP 20	IP 20	IP 20	IP 20	
	Vibration test	[g]	0.7						
	Relative humidity	[%]	Max. 95 IEC 721 (according to VDE 0160)						
	Ambient temperature	[°C]	0 → +40 at full-load operation ²⁾						
	(according to VDE 0160)	[°C]	-25 → +70, storage/transport						
	Frequency converter protection		Grounding and short-circuit proof ³⁾						
	EMC applied standards	Emission	EN 55011, Group 1, Class A, CISPR 11 (with RFI and motor filter)						
(see page 90)	Immunity	IEC 1000-4							
UL file-number		E134261							

²⁾ In the range -10 - 0 °C the unit can start and run, but the display indications and certain operating characteristics will not meet the specifications.

³⁾ Brake option without protection

⁴⁾ Units with built-in RFI filter are not UL-approved.

⁵⁾ For the North American market

■ Technical data (continued)
Mains: 3 × 380-460 V (VLT type 2060: 3 × 380-415 V)

Meets the international standards, UL/cUL ⁴⁾		VLT type	2020	2025	2030	2040	2050	2060 ¹⁾
Constant load (CT):								
Output current	$I_{VLT,N}$ [A]		2.4	2.8	4.0	5.6	7.6	9.7
	$I_{VLT,MAX}$ [A] (60 s)		3.8	4.5	6.4	9.0	12.2	15.5
Output	$S_{VLT,N}$ [kVA]		1.91	2.23	3.19	4.46	6.05	6.97
	$S_{VLT,MAX}$ [kVA] (60 s)		3.06	3.57	5.10	7.14	9.69	11.2
Typical shaft output	$P_{VLT,N}$ [kW]		0.75	1.1	1.5	2.2	3.0	4.0
Max. cable cross section	[mm ²]		4	4	4	4	4	4
Max. motor cable length	[m]		40 (with motor coils IP 10: unscreened cables: 300 m, screened cables: 150 m)					
Output voltage	U_M [%]		0-100 in % of mains voltage					
Output frequency	f_M [Hz]		0-120 or 0-500; programmable					
Rated motor voltage	$U_{M,N}$ [V]		380/400/415/440/460					
Rated motor frequency	$f_{M,N}$ [Hz]		50/60/87/100					
Thermal motor protection during operation			Built-in thermal motor protection (electronic)					
Switching on the output			Unlimited (frequent switching may cause cut-out)					
Ramp times	[s]		0.1-800					
	VLT type		2020	2025	2030	2040	2050	2060 ¹⁾
Max. input current	$I_{L,N}$ [A]		2.3	2.7	3.8	5.3	7.2	9.1
Max. cable cross section	[mm ²]		4	4	4	4	4	4
Max. prefuses	[A]		16	16	16	16	16	20
Bussmann Fuse type KTN-R 250 V AC ⁵⁾	[A]		15	15	15	15	15	
Mains supply voltage	[V]		3 × 380-460 V ±10% 2060: 3 × 380-415 V ±10%					
Mains supply frequency	[Hz]		50/60					
Power factor/cos. ϕ_1			> 0.90/1.0 at rated load					
Efficiency			> 0.97 at rated load					
Switching on the input	times/min.		5					
	VLT type		2020	2025	2030	2040	2050	2060 ¹⁾
Weight [kg]	IP 20		4.0	4.0	4.0	4.2	4.2	4.2
Weight [kg] with built-in RFI filter	IP 20		4.6	4.6	4.6	4.8	4.8	4.8
Power loss at max. load	CT [W]		58	64	78	114	153	196
Enclosure			IP 20	IP 20	IP 20	IP 20	IP 20	IP 20
Vibration test	[g]		0.7					
Relative humidity	[%]		Max. 95 IEC 721 (according to VDE 0160)					
Ambient temperature	[°C]		0 → +40, at full load operation ²⁾					
(according to VDE 0160)	[°C]		-25 → +70, storage/transport					
Frequency converter protection			Grounding and short-circuit proof ³⁾					
EMC applied standards	Emission		EN 55011, Group 1, Class A CISPR 11 (with RFI and motor filter)					
(see page 90)	Immunity		IEC 1000-4					
UL file no.			E 134261					

¹⁾ VLT 2060 has not been UL approved.

²⁾ In the range -10 - 0 °C the unit can start and run, but the display indications and certain operating characteristics will not meet the specifications.

³⁾ Brake option without protection

⁴⁾ Units with built-in RFI filter are not UL-approved.

⁵⁾ For the North American market

Chapter 3

- How to connect the VLT to the motor Page 42
- Survey of connection terminals Page 42
- How to connect control signals Page 43
- Mechanical installation Page 44
- High voltage test Page 44
- Extra protection Page 44
- Prefuses Page 44
- What cables to use Page 44
- For the North American market Page 44

■ How to connect the VLT to the motor

With the VLT 2000 Series you can use all standard three-phase asynchronous motors. Small motors (230/400 V, Δ/Y) are delta-connected to 230 V and star-connected to 400 V. Large motors are delta-connected (400/690 V, Δ/Y).

The motor is connected to the VLT frequency converter by means of terminals at the bottom of the enclosure (the module).

 The rotation direction can be changed by swapping the phase motor cables (terminals 97 and 98) or by using the "Fwd/Rev" key, see also page 47.

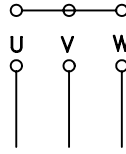

DANFOSS
175HA35.00

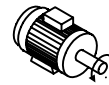
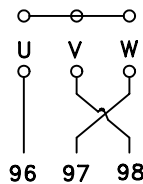
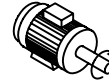
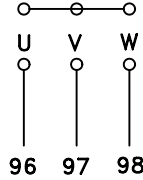

DANFOSS
175HA36.00

■ Survey of connection terminals

All the terminals of a VLT frequency converter are shown below (3 x 380-460 V). The control signals are described overleaf.

 Do not remove the motor and mains terminals when the unit is connected to the mains. Ensure that the power supply has been switched off before you remove the motor and mains terminals.

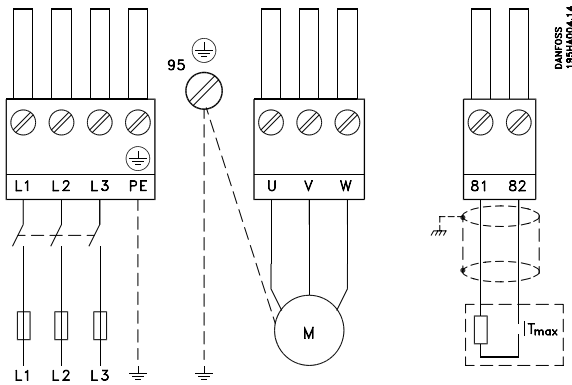

DANFOSS
198HA00A.14

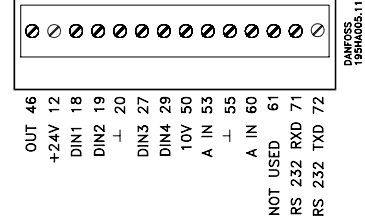
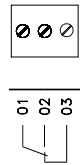

DANFOSS
198HA00S.11

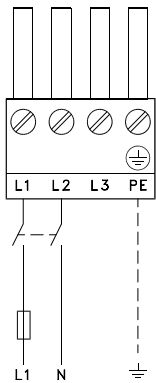

■ How to connect control signals

You can connect the control signals in different ways on the VLT frequency converter.

The control signals can be connected to the two terminal strips at the top of the enclosure.

Each terminal number is based on the survey on page 42.

The control signals can be connected as follows:

Terminal 01-03:	Relay output	Max. 250 V, max. 2 A. Relay: Not activated
Terminal 12:	Supply to digital inputs	24 V DC, max. 140 mA
Terminals 18-19: 27-29	Digital inputs	0-24 V, $R_i = 2 \text{ kohm}$ (max. 37 V for 10 sec.) (min. on-time 80 millisec.)
Terminal 46:	Signal for motor frequency/current	Max. 24 V DC, max. 40 mA, min. 600 ohm
Terminal 50:	Supply to 1 kohm potmeter	10 V DC, max. 12 mA
Terminal 53:	Analogue input voltage	+0-10 V DC, $R_i = 10 \text{ kohm}$, +10 - 0 V
Terminal 60:	Analogue input current	0/4-20 mA, $R_i = 226 \text{ ohm}$, 20 - 0/4 mA
Terminals 71/72	RS 232 standard	71 RXD, 72 TXD, 20 dig. ref.
Terminal 20:	Digital frame	Must be used together with all terminals except for terminals 50, 53 and 60.
Terminal 55:	Analogue frame	Must be used together with terminals 50, 53 and 60



For a description of terminals and how to program the various parameters, see chapter 4.

Terminal 18/402 ★ Start	Latched start	No function	Speed up	Speed select	Reversing	Reset and start	Motor coasting/ start
Terminal 19/403 ★ Reversing	Start reversing	No function	Speed down	Speed select	Reset		
Terminal 27/404 Motor coasting	Quick stop	DC braking	★ Reset and motor coasting	Stop	Reset and start	Speed up	Speed select
Terminal 29/405 ★ Jog (Jog)	Start	Digital reference	Pulse 100 Hz	Pulse 1 kHz	Pulse 10 kHz	Select setup	Reset Reversing Speed down

★ For factory setting of terminal function, see page 105.

■ Mechanical installation

The VLT 2000 Series is cooled by natural convection. Therefore air must be able to pass freely under and over the unit.

The frequency converter must be mounted on a flat vertical surface. This will ensure that the air flow follows the heat reduction.

To enable the frequency converter to get rid of the cooling air, you must allow free air space both above and below the frequency converter.

The ambient temperature must not exceed 40°C so that the VLT frequency converter can dispose of its power loss.

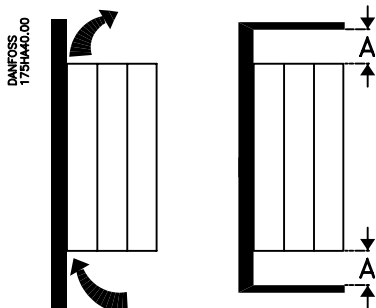

Enclosure	IP 20 *)
A	100 mm

*) The unit is for panel mounting. It should be placed so that it is easily accessible according to Pr EN 50178

■ Side by side mounting

The VLT frequency converters can be installed side by side. There is no need for any space for convection along the side of the enclosure.

■ High voltage test

You can perform a 2.5 kV DC test for 1 second after short-circuiting terminals U, V, W, L₁, L₂ and L₃. Testing is according to the unit's chassis.

It is important to ensure that the filter capacitors have been discharged after the test.

■ Extra protection

As extra protection, error voltage relays or neutral grounding can be used. However, the installation must comply with local health and safety standards. A ground fault can introduce a direct current in the discharge current.

Terminal 95 (earthscrew) intended for reinforced earthing. Any RCD-relays used must comply with local regulations. The relays must be suitable to protect three-phase equipment with bridge rectifier and short discharge on power-up.

■ Prefuses

Prefuses must be installed in the supply feeding the frequency converter.

The correct sizes and ratings can be found in the Technical Data section.

■ What cables to use

Cables for the control signals and the brake cable must be screened in order to comply with EMC specifications.

The maximum cable length and the maximum cable cross section is specified under Technical Data.

Any motor cable screening is connected to the screen termination bracket in the frequency converter (bottom) and the motor.

If non-screened cables are used, the control inputs can occasionally be subject to signal disturbances. Normally such a disturbance will not affect the frequency converter.

■ For the North American market

CAUTION:

It is the responsibility of the user or person installing the drive to provide proper grounding and branch circuit protection for incoming power and motor overload according to National Electrical Codes (NEC) and local codes.

The Electronic Thermal Relay (ETR) in UL listed VLT's provides class 20 motor overload protection in accordance with NEC in single motor applications, when parameter 315 is set to *Trip [2]* and parameter 107 is set to nominal motor (nameplate) current.

Chapter 4

- Operating your VLT Page 46
- The display Page 46
- The push buttons Page 46
- Altering a data value (digits) Page 47
- Altering a data value (text) Page 47
- The light diodes Page 48
- Back to Display group Page 48
- Back to the factory setting Page 48
- How to lock programming function Page 48
- The different groups (modes) Page 49

■ Operating your VLT

You program and control the frequency converter via the control panel. The control panel consists of:

- a display allowing you to interface with the frequency converter.
- push buttons which can have one or several functions (they are described later in this chapter).
- two light emitting diodes (LEDs):
Green light shows that power is on.
Red light indicates alarm.

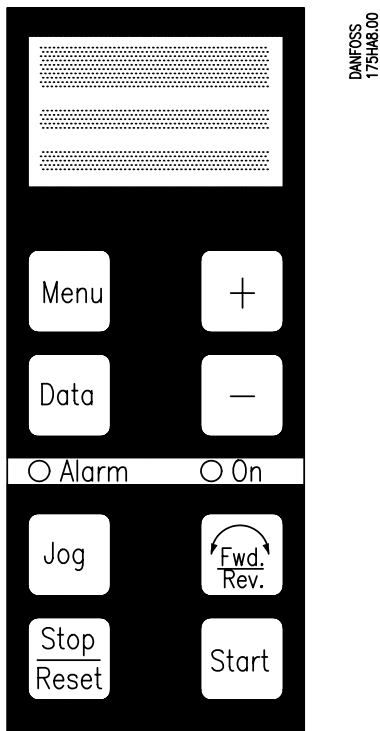

■ The display

Light in the display indicates that the frequency converter is connected to the supply voltage.

The display has three lines:

Line A. Text written with capital letters is shown permanently - also while you are programming the frequency converter.

Line B. States parameters and the rotation direction of the motor.

Line C. Indicates the parameter value and what menu you are in.

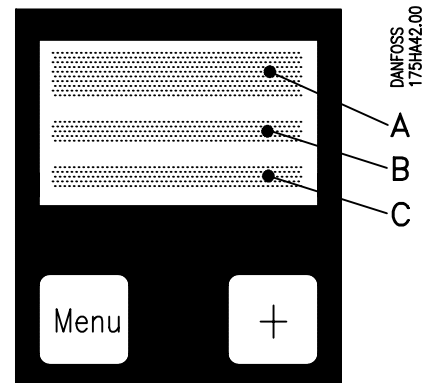

■ The push buttons

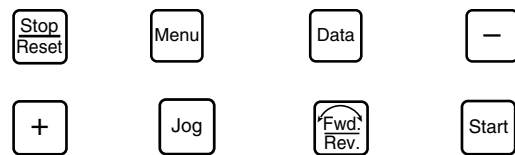

There are eight keys on the frequency converter's control panel.

The different keys and their functions are described overleaf.



-  The “Stop/Reset” key allows you to stop the connected motor during operation, provided you have not chosen to set parameter 007 to *Disable*. Line A of the display will flash after you have pressed the “Stop/Reset” key.
The “Stop/Reset” key does not disconnect the supply voltage and may therefore not be used as a safety switch.

The “Stop/Reset” key can also reset the frequency converter after trip.
To make the key work, set parameter 006 to *Enable*.

-  Press this key to start the connected motor.
-  This key allows you to change from Display group (see page 48) to Menu group (see page 48) and on to Parameter group (see page 49).

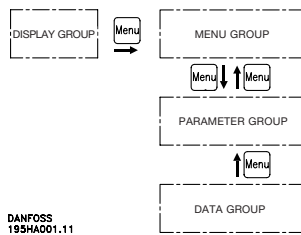

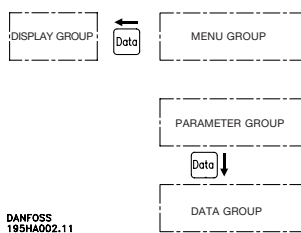

Pressing the “Menu” key will return you from Data group (see page 49) to Parameter group (see page 49) and back to Menu group (see page 48).
Press the “Menu” key in Data group to store altered data values.

-  The “Data” key allows you to change from Parameter group (see page 49) to Data group (see page 49) and from Menu group (see page 48) to Display group (see page 48).



-  The “Jog” key allows you to make the motor run at a fixed, preprogrammed speed or frequency. This frequency is set in parameter 203. Make sure that parameter 009 is set to *Enable* first. The VLT frequency converter is *Jogging* as long as the “Jog” key is held down.

-  This key allows you to change the rotation direction of the motor. The set ramp times (up/down) in parameters 215 and 216 will be used when the key is activated.
For safety reasons the key can only be activated when the VLT frequency converter is set to local operation (parameter 003).
To make this key work you must change the factory setting of parameter 008 from *Disable* to *Enable*.

-   These keys allow you to move round in 5 different groups (modes) in order to choose a menu, a specific parameter or a data value. In Display group (see next **page**) you can choose between 10 different display indications by using the “+” and “-” keys.

■ Altering a data value (digits)

When you press the “Data” key, the digit to the right flashes (active). The other digits can be activated one by one by pressing the “Data” key one, two, three or four times. You can alter the activated digit by pressing the “+” or “-” key.
It is not possible to delete or alter the values of the factory settings.



To alter some values, you will have to stop the motor first by pressing the “Stop/Reset” key.

■ Altering a data value (text)

If the data value of the chosen parameter is a text, you can see the chosen text in the display. The text can be altered by pressing “Data” and then the “+” or “-” key.
The shown text is stored when you leave Data group or on Time out (20 sec.), see page 49 under Data group. It is not possible to delete or alter the values of the factory setting.



To alter some values, you will have to stop the motor first by pressing the “Stop/Reset” key.

■ The light diodes

There are two light diodes on the display. Green light lights up when power is on and red light indicates alarm. See page 82 for a description of alarm indications.

■ Back to Display group

You can always return to the Display group, no matter where you are in the menus. You do it by pressing the "Menu" and the "Data" keys together.

■ Operating without control panel

The frequency converter is preprogrammed. All pre-programming is shown on page 105. You can change the parameters using the serial communication port.

■ Back to the factory setting

1. Switch off the VLT by disconnecting the supply voltage.
2. Press "Menu", "Data" and "Jog" simultaneously.
3. Switch on the VLT and press the keys until the display (line A) writes FIRST.
4. Release the keys. The factory settings have now been activated again.

■ How to lock programming function

You can avoid accidental programming by choosing the data value *Locked* in parameter 013. Even though parameter 013 is set to *Locked*, you can still change data via the serial port.

■ The groups (modes)

You can change between the 5 different groups (modes) shown in the display by means of the "Menu" and "Data" keys.

Display group:

Your VLT will always be in Display group after start. In Display group you can choose between 10 different display indications by means of the "+" and "-" keys:

- Reference in %
- Frequency in Hz
- Display/Feedback
- Current A
- Torque %
- Current supply kW
- Output voltage V
- DC voltage V (intermediate)
- Thermal motor load %
- Thermal inverter load %

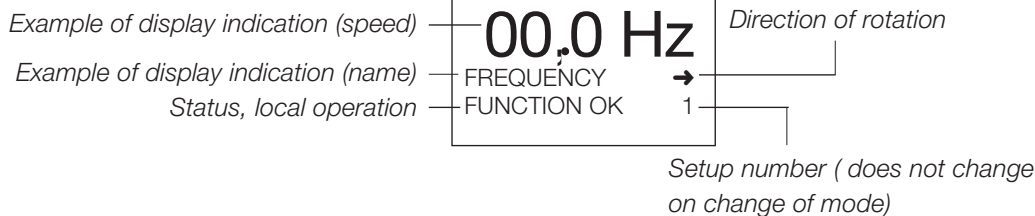

Menu group:

You can choose Menu group from either Display group or Parameter group by using the "Menu" key.

In Menu group you can see the different menus (0-6) in which you can find the parameters. You change between the menus by means of the "+" and "-" keys.



■ The groups (modes) (continued)

Parameter group:

You enter Parameter group from either Menu group or Data group by using the “Menu” key.

In Parameter group you can select the parameter(s) you want to alter. You change between the various parameters in the menu by means of the “+” and “-” keys.



Data group:

You can only enter Data group from Parameter group and only by using the “Data” key. In Data group you can alter the data value of the parameter you have chosen in Parameter group. You switch between the different data values by means of the “+” and “-” keys.

If you have altered a data value, this will not be stored. Press the “Data” key once to return.



To store the new (selected) data value, you must leave Data group.

You do this by pressing the “Menu” key, or it takes place automatically after 20 seconds.

If the VLT frequency converter is in Data group for more than 20 sec. and if no activity has been registered, you leave the Data group automatically.

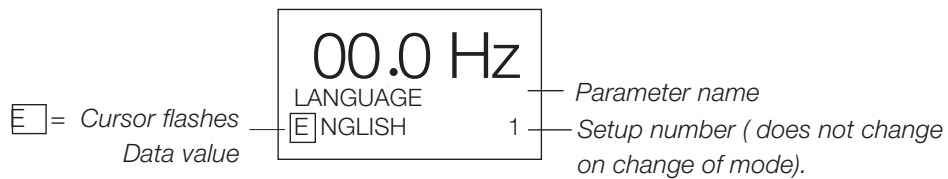

Alarm group:

The VLT frequency converter will enter Alarm group upon a trip condition.



If TRIP is displayed the operation has stopped and you must press the “Stop/Reset” key to reset the VLT. If TRIP LOCKED is displayed you must switch off the VLT and then switch it on again, and then press the “Stop/Reset” key.

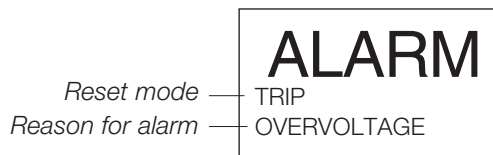

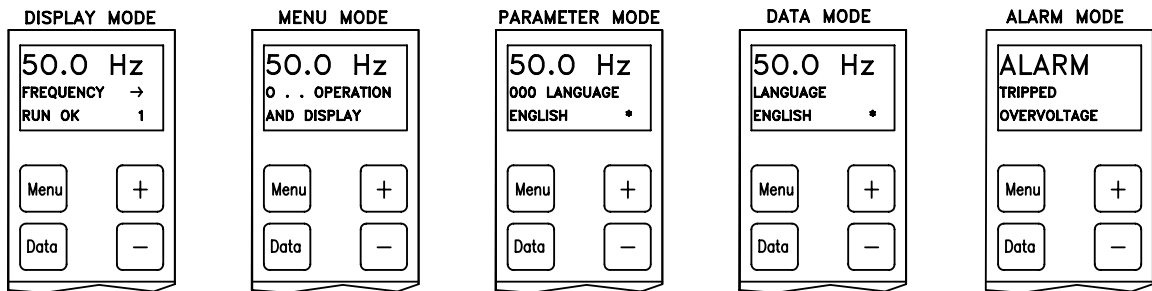
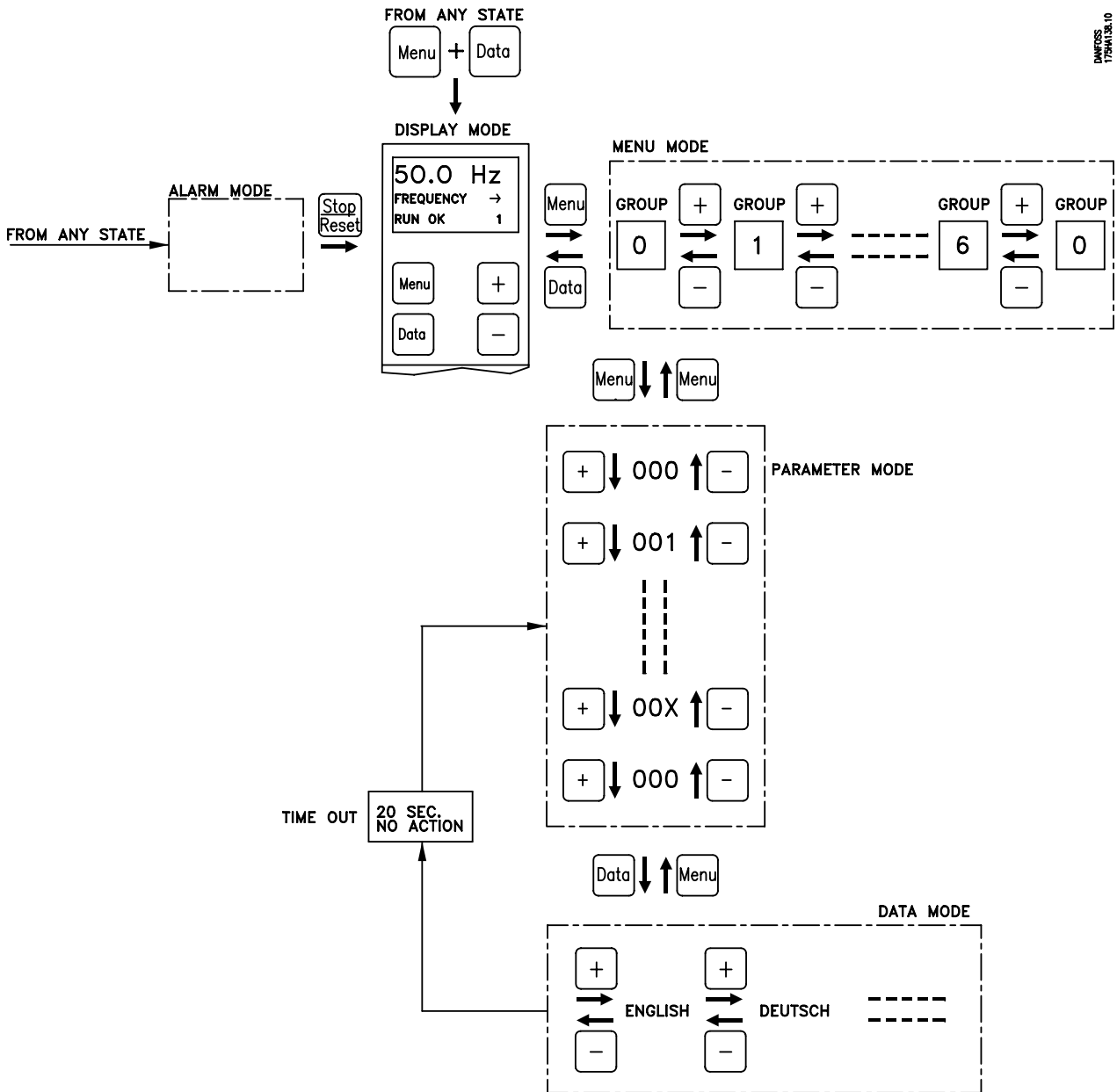

Chapter 5

- Operation and display (group 0) Page 52
- Load and motor (group 1) Page 52
- Serial data interface (group 5) Page 54
- VLT status Page 56
- VLT control commands Page 57

■ Operation and display (group 0..)

In this group you will find parameters concerning the display read-out, local operation and setup handling.

Note: The choice between the 10 different display read-outs mentioned on page 48 is not an element of this group.

■ Load and motor (group 1)

This group of parameters has been reserved for the adjustments necessary to adapt the VLT frequency converter to the required application and motor.

The settings of parameters 101-112 will be suitable for normal applications using standard induction motors at constant torque load without parallel-coupled motors.

Open loop:

If parallel-coupled motors are used on a VLT frequency converter output terminal, or any synchronous type of motor is used, select the open loop mode.

Further adjustments may improve the effective torque or give a more accurate speed, if the motor data deviates from the typical standard values.

Manual tuning is possible in parameters 107-112 for adjustment of values.

Control with open loop

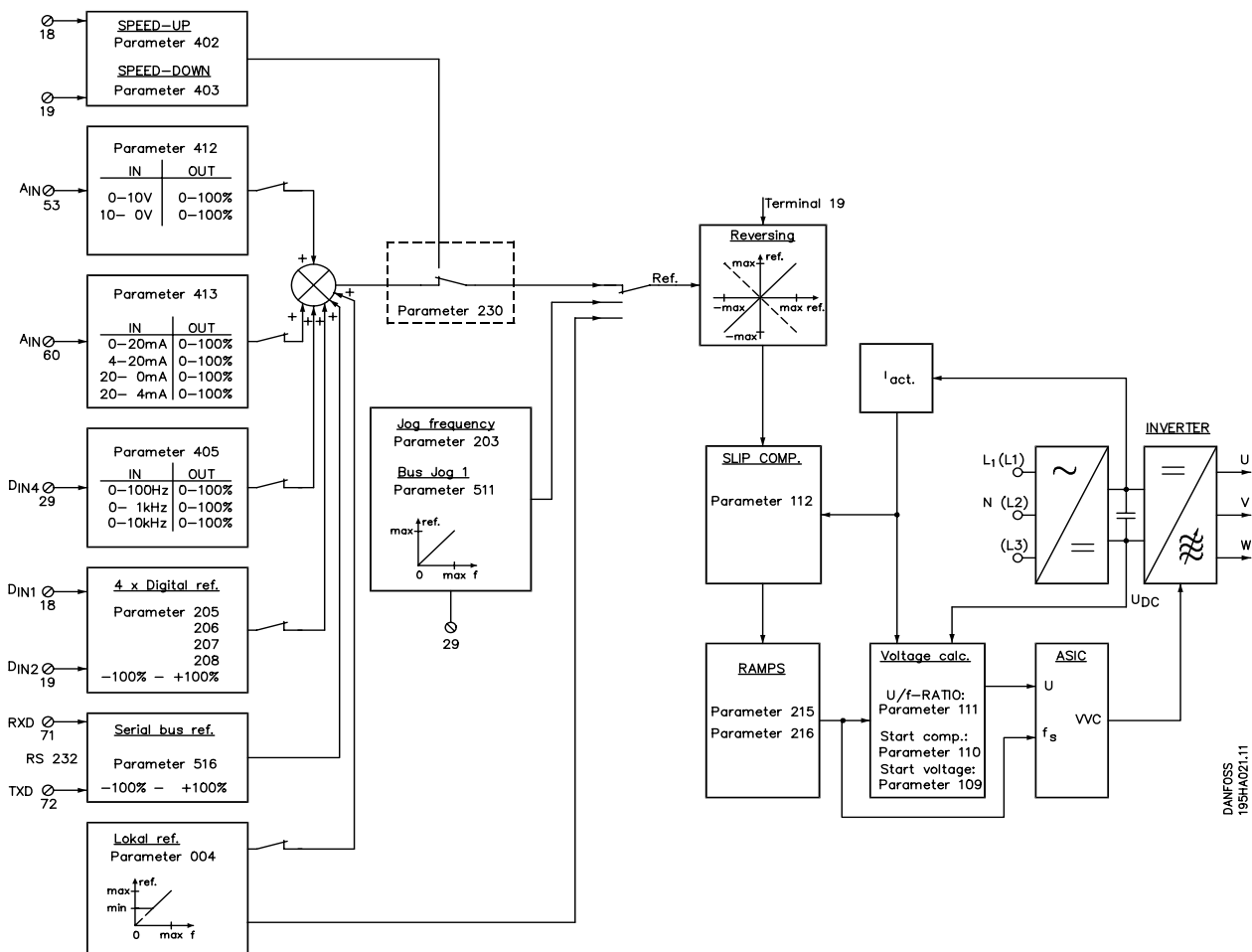

■ Load and motor (group 1..) (continued)

Closed loop control - PI controller:

If closed loop control is required, the transmitter, tachometer or encoder should supply one of the analogue standard signals (e.g. 0-10 V, 0-20 mA, 4-20 mA) or a pulse signal frequency of max. 100 Hz, 1 kHz or 10 kHz (programmable).

The reference signal can either be fixed internally (digital reference) or be a standard analogue signal or pulse signal.

The feedback value should be 50-80% of the reference signal. It is not possible to select the same type of signal (voltage, current, pulse) for both the reference and the feedback.

At start the output frequency is determined by the reference and the feed forward factor (parameter 119) and the f_{MAX} and f_{MIN} settings of the frequency converter. When a feedback signal is registered, the PI controller then corrects the output frequency by comparing with the reference/feedback signals.

At stop the output (integrator) is set to 0 so that a restart follows the normal start situation.

Control with closed loop

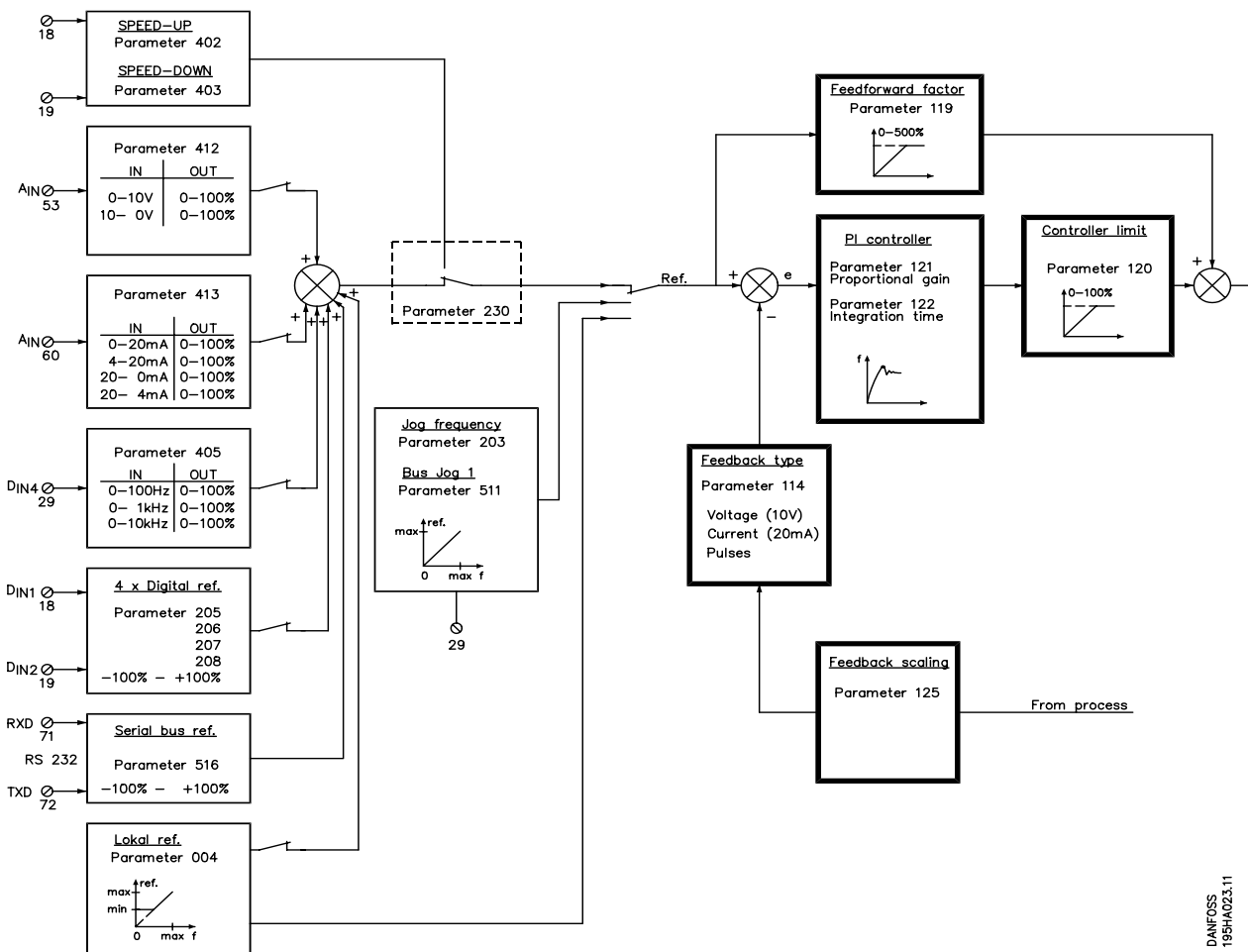

DANFOSS
195HA023.11

■ Serial data interface (group 5..)

Using the serial RS 232 port (terminals 71 and 72) you can read and set parameters of the VLT frequency converter and issue reference and control commands. The serial port can be used for point-to-point communication between the VLT frequency converter and a PC. Communication takes place by means of a protocol specified by Danfoss, and using the echo function (para. 500) you can connect several VLT frequency converters.

The data format consists of 10 bits:

- One start bit (logical 0)
- Eight data bits
- One stop bit (logical 1)

Set the baud rate (rate of transmission) in parameter 501 and the address of each unit in parameter 500.

Protocol:

The communication protocol for the VLT 2000 Series consists of 22 ASCII characters. These characters make it possible to operate, set and read parameters, and to receive status feedback from the VLT frequency converter.

The communication takes place in the following way:

The master sends a telegram to a VLT frequency converter. Then the master awaits a reply from the frequency converter before sending a new message. The reply to the master resembles the telegram sent by the master, but now contains any updated data values and the status of the frequency converter.

Data format

Telegram format

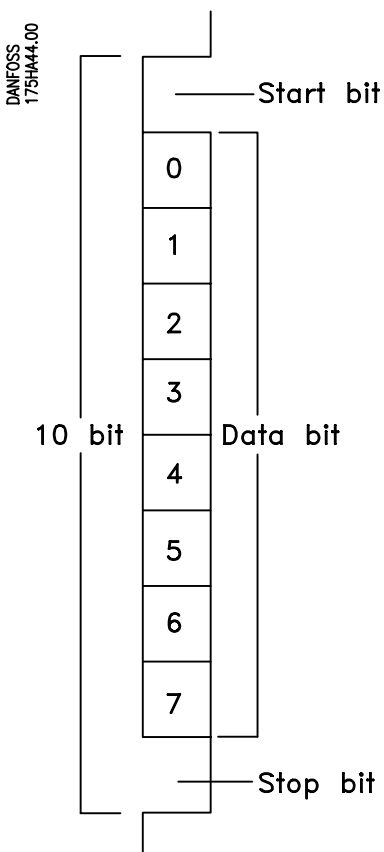

Function	byte #	ASCII
Start byte	1	<
Address	2	
	3	
	4	
Control char. Control/status word	5	
	6	
	7	
	8	
Parameter #	9	
	10	
	11	
	12	
Sign Data	13	
	14	
	15	
	16	
	17	
	18	
Comma Check sum	19	
	20	
	21	
Stop byte	22	>

■ Serial data interface (group 5) (continued)

Byte 1:

Start byte which in this case must be the character < (ASCII: 60).

Byte 2, 3:

The two-digit address of the frequency converter. This address is also programmed in parameter 500. Sending to address 00 means broadcasting to all units connected to the serial port. None of the units will reply, but they will carry out the command.

Byte 4:

Control parameter telling the VLT frequency converter what to do with the following data values.

U (update):

Means that the data value (14-18) must be recorded into the frequency converter.

R (read):

Means that the master wants to read the data value of the parameter stated in bytes 9-12.

C (control):

Means that the frequency converter only reads the four command bytes (5-8) and returns with status. Parameter number and data value will be ignored.

I (read index):

Means that it reads index and parameter and returns with status. Parameter is stated in bytes 9-12 and index is stated in bytes 13-18.

Parameters with indexes are read-only parameters. Action will be taken on the control word.

Byte 5-8:

Control and status words are used to send commands to the frequency converter and send status from the frequency converter to the master.

Byte 9-12:

The parameter number is set in these bytes.

Byte 13:

Used for the sign for the data value in bytes 14-18. All characters other than "-" are taken as "+".

Byte 14-18:

The data value of the parameter stated in bytes 9-12 is set in these bytes. The value must be a whole number. If a decimal point is needed it is stated in byte 19.

Note:

Some data values have brackets with a number, e.g. [0]. Use this number instead of the text data value.

Byte 19:

The position of the decimal point in data values stated in bytes 14-18. The number states the number of characters after the decimal point. Byte 19 can thus be 1, 2, 3, 4 or 5.

Example: The number 23.75 is stated as follows:

Byte No.	13	14	15	16	17	18	19
ASCII character	+	2	3	7	5	0	3

If byte 19 is 9 this indicates an unknown parameter.

Byte 20, 21:

Used for summary control. If no control is necessary cancel the function using ? (ASCII: 63) in the two bytes.

Byte 22:

Stop byte stating the end of the telegram. The character > is used (ASCII: 62)

■ VLT status

The four control and status bytes are used to send control commands to the frequency converter when the telegram is sent from the master and to send sta-

tus from the frequency converter to the master when the telegram is returned from the VLT frequency converter.

The four bytes operate as status from the frequency converter with the following functions:

ASCII		Status word															
		Byte 8				Byte 7				Byte 6				Byte 5			
		T I M E R S O K / L I M I T	C U R R E N T O K / L I M I T	V O L T A G E O K / L I M I T	V L T O K / S T A L L I N G A U T O S T A R T	N O T R U N N I N G / R U N N I N G	O U T O F R A N G E / F R E Q U E N C Y L I M I T O K	L O C A L O P E R A T I O N / B U S C O N T R O L	S P E E D · R E F / S P E E D = R E F	N O W A R N I N G / W A R N I N G	N O S T A R T I N H I B I T / S T A R T I N H I B I T	O N 3 / O F F 3	O N 2 / O F F 2	N O F A U L T / T R I P	M O T O R C O A S T I N G / P O S S I B L E	V L T N O T R E A D Y / R E A D Y	C T R N O T R E A D Y / R E A D Y
15	14	13	12	11	10	09	08	07	06	05	04	03	02	01	00		
@	1/2 byte			1/2 byte				1/2 byte				1/2 byte					
A	0	0	0	0	0	0	0	0	0	0	0	0	0	0	0		
B	0	0	0	0	0	0	0	0	0	0	0	0	0	0	0		
C	0	0	0	1	0	0	0	1	0	0	0	0	0	0	1		
D	0	0	0	1	0	0	0	1	0	0	0	0	0	0	1		
E	0	0	1	0	0	0	0	0	1	0	0	0	0	1	0		
F	0	1	0	0	0	1	0	0	1	0	0	0	1	0	0		
G	0	1	0	0	0	1	0	0	1	0	0	0	1	0	0		
H	0	1	1	0	0	1	1	0	1	1	0	0	1	1	0		
I	0	1	1	1	0	1	1	0	1	1	1	0	1	1	1		
J	1	0	0	0	1	0	0	0	1	0	0	0	1	0	0		
K	1	0	0	1	1	0	0	1	0	0	1	0	1	0	1		
L	1	0	1	1	1	0	1	1	0	1	1	1	0	1	1		
M	1	1	0	0	1	1	0	0	1	1	0	0	1	0	0		
N	1	1	0	1	1	1	0	1	1	1	0	1	1	1	0		
O	1	1	1	1	1	1	1	1	1	1	1	0	1	1	1		

Note: Each byte consists of 8 bits, but the frequency converter uses only the last 4 bits.

■ VLT control commands

The four control and status bytes are used to send control commands to the frequency converter when the telegram is sent from the master, and to send status from the frequency converter to the master when the telegram is returned from the VLT frequency converter.

When these four bytes are used for control, they have the following meaning:

- OFF 1: Makes a normal ramp stop of the motor and opens the relay output of the frequency converter (relay off).
- OFF 2: Makes a motor coast and opens the relay output (relay off).
- OFF 3: Same as OFF 1, but the motor makes a quick-stop.
- Bit 10: This bit has to be 1, if any of the control commands should cause a reaction.

ASCII	0 / 1	Control word															
		Byte 8				Byte 7				Byte 6				Byte 5			
		NO FUNCTION / REVERSING	SETUP SELECT / 2	NO FUNCTION	SPEED SELECT MSB	SPEED SELECT LSB	DATA NOT VALID / VALID	NO FUNCTION	JOG 1 OFF / ON	NO FUNCTION / RESET	RAMP STOP / START	HOLD / ENABLE RAMP	QUICK STOP / RAMP ON	MOTOR COASTING / ENABLE	OFF 3 ON	OFF 2 ON	OFF 1 ON
15	14	13	12	11	10	09	08	07	06	05	04	03	02	01	00		
@		1/2 byte				1/2 byte				1/2 byte				1/2 byte			
A		0	0	0	0	0	0	0	0	0	0	0	0	0	0	0	0
B		0	0	0	1	0	0	0	0	0	0	0	1	0	0	0	1
C		0	0	1	0	0	0	1	0	0	0	1	0	0	0	1	0
D		0	0	1	1	0	0	1	1	0	0	1	1	0	0	1	1
E		0	1	0	0	0	1	0	0	0	1	0	0	0	1	0	0
F		0	1	0	1	0	1	0	1	0	1	0	1	0	1	0	1
G		0	1	1	0	0	1	1	0	0	1	1	0	0	1	1	0
H		1	0	0	0	1	0	0	0	1	0	0	0	1	0	0	0
I		1	0	0	1	1	0	0	1	1	0	0	1	1	0	0	1
J		1	0	1	0	1	0	1	0	1	0	1	0	1	0	1	0
K		1	0	1	1	1	0	1	1	1	0	1	1	1	0	1	1
L		1	1	0	0	1	1	0	0	1	1	0	0	1	1	0	0
M		1	1	1	0	1	1	1	0	1	1	1	0	1	1	1	0
N		1	1	1	1	1	1	1	1	1	1	1	1	1	1	1	1
O		1	1	1	1	1	1	1	1	1	1	1	1	1	1	1	1
P		X	X	X	X	X	X	X	X	X	X	X	X	X	X	X	X
-		X	X	X	X	X	X	X	X	X	X	X	X	X	X	X	X

Note: Each byte consists of 8 bits, but the frequency converter uses only the last 4 bits.

Chapter 6

■ Description of parameters Page 61

■ Description of parameters
■ 000 Language select (LANGUAGE)

 Value:

★ English (ENGLISH)	[0]
German (DEUTSCH)	[1]
French (FRANCAIS)	[2]
Danish (DANSK)	[3]

 Function:

The choice in this parameter defines the language to be shown in the display.

 Description:

You can choose between *English, German, French and Danish*.

■ 001 Menu setup select (MENU SETUP)

 Value:

★ Setup (SETUP 1)	[1]
Setup (SETUP 2)	[2]
Multi setup (MULTI SETUP)	[5]

Setup	Terminal 29
1	0
2	1

 Function:

You can select a menu setup which is different from the factory setting and store it in *Setup 1* or *Setup 2*.

 Description:

You start by selecting the setup you want to make or alter. You can choose between *Setup 1* or *Setup 2*. Then you can alter any data value you like. Your alterations make a setup different from the factory setting. If you choose *Multi-setup* you can switch between the two setups via terminal 29. The parameters which can be chosen for the two setups have been specially selected. See page 102. For how to change to factory setting see page 48.

■ 002 Setup copy (MENU SET COPY)

 Value:

★ No copy (DO NOT COPY)	[0]
Copy setup 1 to 2 (COPY 1 TO 2)	[6]
Copy setup 2 to 1 (COPY 2 TO 1)	[7]
Copy from fact.setting to 1 (FACTORY TO 1)	[8]
Copy from fact.setting to 2 (FACTORY TO 2)	[9]

 Function:

You can copy *Setup 1* to *Setup 2* and vice versa. You can always copy the factory setting back to *Setup 1* or *Setup 2*.

 Description:

Copying starts when you have recorded the required data value and have stored it by pressing the "Menu" key. The software will always return to *No copy* when copying has been accomplished. Copying takes about 45 seconds. Time out does not activate the copying function.

■ 003 Operation site (LOCAL /REMOTE)

 Value:

★ Remote (REMOTE)	[0]
Local with external stop (LOC/EXT.STOP)	[1]
Local (LOCAL)	[2]
Local and remote (LOCAL+REMOTE)	[3]

 Function:

You can choose four different operation sites: *Remote, Local with external stop, Local and Local and remote*.

 Description:

If you choose *Remote*, you can control the frequency converter via the control terminals. However, you can still use the stop key of the control panel (provided you have not chosen to disable this function in parameter 007).

If you choose *Local with external stop* you must disconnect the connection between terminals 12 and 27 to activate stop. *Local with external stop* can only be chosen if *Motor coasting, Quick stop, Reset and motor coasting or stop* have been chosen in parameter 404 (terminal 27).

Choose *Local* if you want to operate the unit via the keyboard (must be activated in parameter 007).

Local and remote adds local and external reference. This function is selected for access to local reference even when the unit is operated remotely.

★ = Factory setting. Text in () = Display text. The figures in [] are used in bus communication.

004 Local reference (LOCAL SPEED)

Value:

 $0-f_{MAX}$

Function:

You choose *Local reference* if you want to set the speed (frequency) via the control panel.

Description:

To use this parameter you must choose *Local with external stop* or *Local and remote* in parameter 003. The output frequency of the frequency converter can be changed by means of the “+” and “-” keys. If the mains supply is disconnected the value changes to 0.00. Parameter 004 cannot be controlled via the serial bus, RS 232.

There is no automatic switch back to Parameter group from this parameter. In parameter 010 you can lock data changes in parameter 004.

005 Display value (VALUE AT MAX.)

Value:

1 - 9999 ★ 1000

Function:

You can choose to have the speed/frequency displayed without the unit Hz behind the value.

Description:

The value will only be read out if *Display* is selected in Display group.

It is not possible to change Hz to another unit.

006 Local reset (LOCAL RESET)

Value:

Disable (DISABLE) [0]

★ Enable (ENABLE) [1]

007 Local start / stop (LOC START/STOP)

Value:

Disable (DISABLE) [0]

★ Enable (ENABLE) [1]

008 Local reversing (LOCAL/FWD/REV)

Value:

★ Disable (DISABLE) [0]

Enable (ENABLE) [1]

009 Local jog (LOCAL JOG)

Value:

Disable (DISABLE) [0]

★ Enable (ENABLE) [1]

010 Local reference (LOC REFERENCE)

Value:

Disable (DISABLE) [0]

★ Enable (ENABLE) [1]

Enable and save (ENABLE AND SAVE) [2]

Function:

You can enable/disable the function via the control panel. Furthermore you can choose whether it must be possible to change the output frequency via parameter 004.

Description:

If you choose *Disable* in parameter 006, 007, 008 or 009 you cannot activate the function via the control panel.

If you choose *Disable* in parameter 010 the output frequency cannot be changed via parameter 004.

You can prevent data change by setting parameter 013 to *Locked*.

If you choose *Enable and save* a change of local speed reference will be saved automatically after 15 sec.

013 Data change lock (DATA CHC. LOCK)

Value:

★ Not locked (NOT LOCKED) [0]

Locked (LOCKED) [1]

Function:

There is a way to avoid unintended programming.

Description:

If you choose *Locked* you cannot make any data change in any parameter. However, it is still possible to change the local reference.

If data change is attempted with data change lock, the display shows: DATA LOCKED.

★ = Factory setting. Text in () = Display text. The figures in [] are used in bus communication.

■ 101 Speed control (SPEED CONTROL)

Value:

Open loop (OPEN LOOP)	[0]
★ Slip comp. (SLIP COMP)	[1]
Closed loop (CLOSED LOOP)	[2]

Function:
 You can choose among three different kinds of speed control: *Open loop*, *Slip compensated* and *Closed loop*.

Description:
 Choose *Slip compensation* for normal operation, where the speed must be constant no matter what the load is. Choose *Open loop* when the motors used are parallel-connected in parallel or when synchronous motors are used. Choose *Closed loop* when you want operation with process feedback. For closed loop operation you must choose the feedback type in parameter 114 (current, voltage or pulses). See also the section on PI controller, page 53.

■ 102 Current limit control (CURRENT LIMIT)

Value:

★ Preprogrammed value (PROGRAM SET)	[0]
Voltage signal (10 VDC SIGNAL)	[1]
Current signal (20 mA SIGNAL)	[2]

Function:
 You can choose to control the speed by means of the current limit. This makes indirect torque control possible. The current limit can be set in parameter 209 or by means of a current or voltage signal in parameter 412 or 413.

Description:
 Choose between controlling the current limit via parameter 209 or one of the analogue inputs, terminal 53 or 60. *10 V / 20 mA* corresponds to 160 % current (2030: 140 %).
 Do not select the same signal for PI control.

■ 103 Motor power (MOTOR POWER)

Value:

Under size	[0]
★ Nom. size	[1]
Over size	[2]

Function:
 Using this parameter you can select the kW value closest to the motor's rated output. The frequency converter has three preset kW values. The exact kW value will depend on unit type.

Description:
 Read the rated motor power on the type plate of the motor and choose the relevant factory setting for the motor size. Parameters 107, 108, 109, 110, 111 and 112 change automatically when the value in parameter 103 is changed.

■ 104 Motor voltage (MOTOR VOLTAGE)

Value:

Only 200-240 V units	
200 V (200 V)	[0]
208 V (208 V)	[1]
★ 220 V (220 V)	[2]
230 V (230 V)	[3]
240 V (240 V)	[4]
Only 380-460 V units	
380 V (380 V)	[0]
★ 400 V (400 V)	[1]
415 V (415 V)	[2]
440 V (440 V)	[3]
460 V (460 V)	[4]

Function:
 Using this parameter you can select the rated voltage closest to the motor's voltage.

Description:
 You can choose among different voltage values. The value is selected on the basis of the data on the motor plate. Parameters 107, 108, 109, 110 and 111 are changed automatically when the value of parameter 104 is changed.

★ = Factory setting. Text in () = Display text. The figures in [] are used in bus communication.

■ 105 Motor frequency (MOTOR FREQ)

Value:

★ 50 Hz (50 Hz)	[0]
60 Hz (60 Hz)	[1]
87 Hz (87 Hz)	[2]
100 Hz (100 Hz)	[3]

Function:

Using this parameter you can select the frequency equivalent to the motor's rated frequency.

Description:

You can choose among 4 different frequency values. The value is selected on the basis of the data on the type plate of the motor. The U/f ratio in parameter 111 is changed automatically.

■ 107 Motor current (MOTOR CURRENT)

Value:

$$I_{MAG} (\text{par.108}) - I_{VLT,MAX}(\text{PAR. 209})$$

Function:

The motor's rated current is included in the VLT frequency converter's calculation of e.g. torque, thermal motor protection and cut-out level.

Description:

You must record the rated motor current (Amp). The value will appear from the motor plate.

■ 108 Motor magnetising current (MOTOR MAG.AMP)

Value:(automatically set)

$$0.3 - I_{M,N} (\text{par.107})$$

Function:

The VLT frequency converter uses the value for different calculations such as compensation.

Description:

If the factory setting is unsuitable the motor current on running idle should be measured with a suitable amperemeter (RMS). The magnetising current is then set to the measured value.

■ 109 Start voltage (START VOLTAGE)

Value: (automatically set)

$$0 - (U_{M,N} + 10\%)$$

Function:

By increasing the start voltage you can achieve higher starting torque. Small motors (< 1.0 kW) usually require high start voltage. On parallel coupling of motors, only the start voltage can be used to increase the starting torque.

Description:

Do not forget to consider that the motor must be able to start with the required torque:

1. Choose a value to make start possible with the load in question.
2. Reduce value until start with the load in question is just possible.
3. Choose a value where operation in the rest of the frequency range is possible at the lowest possible current consumption.

If the start voltage makes normal operation impossible, you can change the U/f ratio in parameter 111.



Warning: If the use of start voltage is overdone it can lead to magnetic saturation and motor overheating and the frequency converter may trip out. Therefore take care when using the start voltage parameter.

★ = Factory setting. Text in () = Display text. The figures in [] are used in bus communication.

■ 110 Start compensation (START COMP.)

Value: (automatically set)

0.00 - 99 V/A

Function:

Using this parameter you can make a load-dependent torque adaptation. This is for example used for motors and applications where there is a large difference between the motor's full-load current (parameter 107) and no-load current (parameter 108).

Description:

If the factory setting is not sufficient, you can set the parameter so that the motor can start at the actual load. You can also combine start compensation with parameter 109.



Warning: Should not be used with synchronous motors and parallel-coupled motors and where quick load changes may occur. To avoid instability do not increase the value more than necessary.

■ 111 U/f ratio (V/F. RATIO)

Value: (automatically set)

0.00 - 20 V/Hz

Function:

Using this parameter you can change the linear ratio between voltage (U) and frequency (f) to ensure correct motor magnetisation, optimal dynamics, accuracy or efficiency,

Description:

Use the parameter only if you cannot record the correct motor data in parameters 104 and 105. The value can be calculated as follows:

$$U/f = \frac{\text{Motor voltage (para. 104)}}{\text{Motor frequency (para. 105)}}$$

The value of the factory setting is based on no-load operation. Therefore it is lower than the value calculated.

The compensation will give the necessary voltage supplement.

■ 112 Slip compensation (SLIP COMP)

Value: (automatically set)

0.0 - 20Hz

Function:

Slip compensation increases the output frequency and voltage of the VLT frequency converter with an increasing load to compensate for the motor's increasing slip (loss). This achieves a load-independent speed.

Description:

Choose a value so that the speed remains constant when the load increases. If the value is too high the speed increases with the load. This may lead to unstable motor operation.

When you use synchronous motors and motors connected in parallel, set slip compensation to 0 Hz. Slip compensation should be avoided in case of high dynamics.

■ 114 Feedback type (FEEDBACK TYPE)

Value:

Voltage (VOLTAGE 10 V) [0]

★ Current (CURRENT 20 mA) [1]

Pulses (PULSES) [2]

Function:

Using this parameter you can choose the process feedback type when you use a PI controller (must be selected). See also the description of parameter 101 and the section on the PI controller, page 53.

Description:

When using the PI controller, you must use one of the inputs of terminal 29, 53 or 60 for the feedback signal. Parameters 405, 412 and 413 must be set according to the feedback signal selected. Naturally these choices block the same type of reference signal.

★ = Factory setting. Text in () = Display text. The figures in [] are used in bus communication.

■ 119 FF factor (FEED FWD FACTR)

Value:

0 - 500% ★ 100%

Function:

This parameter is used in connection with a PI controller. The FF factor sends a large or small part of the reference signal around the PI controller so that the PI controller only affects part of the control signal. Any change of the setpoint will therefore directly affect the motor speed. The FF factor gives high dynamics at changes of the setpoint and less overshoot.

Description:

You can choose the required percentage value in the interval f_{MIN} - f_{MAX} . Choose a value above 100% if the setpoint variations are only minor.

■ 120 Controller range (CONTRL RANGE)

Value:

0 - ★ 100%

Function:

The controller range (band width) limits the output from the PI controller as a percentage of f_{MAX} .

Description:

You can choose a percentage value of f_{MAX} . If the controller range is reduced the speed variations will be lower during adjustment.



Warning: The output frequency is limited by $0.9 \times f_{MIN}$ and $1.1 \times f_{MAX}$ no matter what the band width setting is. The controller can therefore be active without affecting the output frequency. When the PI controller is active the output frequency can exceed f_{MAX} by 10%.

■ 121 Proportional gain (PROPRT /L GAIN)

Value:

0.01 - 10.00 ★ 0.01

Function:

The proportional gain indicates how many times the deviation (between feedback signal and setpoint) must be amplified.

Description:

Fast regulation is obtained when amplification is high. The value can be too high, and then the process may become unstable.

■ 122 Integral time (INTEGRAL TIME)

Value:

0.01 - 7200 sec. ★(OFF)

Function:

The integral time determines how long the PI controller takes to regulate the signal. The integral time will delay/dampen the signal.

Description:

Fast regulation is obtained when the integral time is short. The value can be too short, making the process unstable. When the integral time is long regulation is slow. "Off" means that the function is not active.

■ 125 FB-factor (FEEDBACK SCALE)

Value:

0 - 500% ★ 100%

Function:

The FB factor is used if the transmitter cannot be selected optimally to the scaling range of the input signals.

Description:

This parameter is only used if the feedback signal in parameter 114 is not of a suitable level. If you choose 100% the feedback signal is not changed.

★ = Factory setting. Text in () = Display text. The figures in [] are used in bus communication.

■ 200 Frequency range (FREQ RANGE)

Value:

- | | |
|--------------|-----|
| ★ 0 - 120 Hz | [0] |
| 0 - 500 Hz | [1] |

Function:

Using this parameter you can set and thus limit the output frequency range of the VLT frequency converter.

Description:

In most cases you can use 0-120 Hz.



Warning: Only choose 0-500 Hz if you use special motors designed for high speeds.

■ 201 Min. frequency (MIN FREQUENCY)

Value:

- | | |
|-----------------|-----|
| 0.0 - f_{MAX} | ★ 0 |
|-----------------|-----|

Function:

Using this parameter you can record a lowest frequency limit corresponding to the required minimum motor speed. The minimum frequency can never be higher than the maximum frequency.

Description:

You can choose a value from 0.0 Hz to the value selected in parameter 202 for max. frequency.

■ 202 Max. frequency (MAX FREQUENCY)

Value:

- | | |
|------------------------|---------|
| 0.0-value in para. 200 | ★ 50 Hz |
|------------------------|---------|

Function:

Using this parameter you can record a highest frequency limit corresponding to the motor's maximum speed.

Description:

 You can choose a value from f_{MIN} to the value selected in parameter 200 for f_{MAX} (120 Hz or 500 Hz).

When the PI controller is active the maximum frequency can be exceeded by 10%. The same applies when slip compensation is active.

■ 203 Jog frequency (JOG FREQUENCY)

Value:

- | | |
|----------------|---------|
| 0.0- f_{MAX} | ★ 10 Hz |
|----------------|---------|

Function:

This is the fixed output frequency you can select when the "Jog" key is active. See also the description of parameter 511.

Description:

 The jog frequency can be lower than f_{MIN} (para. 201) but the highest output frequency is limited by f_{MAX} (para. 202)

★ = Factory setting. Text in () = Display text. The figures in [] are used in bus communication.

■ 204 Digital reference type (DIG. REF. TYPE)

Value:

- ★ Sum (SUM) [0]
- Relative (RELATIVE) [1]

Function:

The digital references are generated internally in the unit and presented as a percentage of the difference between the f_{MAX} and f_{MIN} selected in parameters 201 and 202, added to f_{MIN} .

Description:

If *Sum* is selected, one of the digital references (parameters 205-208) is added as a percentage of the difference between f_{MAX} and f_{MIN} with the other references. If *Relative* is selected, one of the digital references (parameters 205-208) is added as a percentage of the sum of the other references.

■ 205 Digital reference 1 (DIG. REF. 1)

Value:

-100.00% - +100.00% ★ 0

■ 206 Digital reference 2 (DIG. REF. 2)

Value:

-100.00% - +100.00% ★ 0

■ 207 Digital reference 3 (DIG. REF. 3)

Value:

-100.00% - +100.00% ★ 0

■ 208 Digital reference 4 (DIG. REF. 4)

Value:

-100.00% - +100.00% ★ 0

Function:

The digital speed references are generated internally in the unit and presented as a percentage of the f_{MAX} value. The percentage value is added to any analogue reference from terminals 53 and 60.

Description:

By means of terminal 29 you can switch between the other references (terminal 29 = 0 V) and the sum of the other/digital references (terminal 29 = 24 V).

You must select *Digital reference select* in parameter 402 and 403 to select one of the digital references:

18/27	19	Terminal
0	0	Digital reference 1
1	0	Digital reference 2
0	1	Digital reference 3
1	1	Digital reference 4

■ 209 Current limit (CURRENT LIMIT)

Value:

0.3 - $I_{VLT,MAX}$

Function:

Using this parameter you can set the maximum allowable output current of the VLT frequency converter. If the current limit is exceeded the output frequency is reduced until the current falls to the current limit. The output frequency does not increase to the set reference value until the current has fallen to below the current limit.

Description:

The factory setting corresponds to a load which is 160% (VLT 2030 1/3 x 208-240 V: 140%) of the rated output current. If you want to use the current limit as motor protection you must record the rated motor current.

Using parameter 310 you can record how long you want the frequency converter to operate at current limit before tripping out.

The load range of 100-160% is only for intermittent operation and therefore the unit can only give an output of 160% (VLT 2030 1/3 x 208-240 V: 140%) for 60 seconds.

Operation time is extended at decreasing load and is unlimited at 100%.



If the switching frequency is higher than 4.5 kHz this period will be shorter.

★ = Factory setting. Text in () = Display text. The figures in [] are used in bus communication.

■ 210 Warning: frequency low (LOW FREQ WARN)

Value: _____
 0 - 500 Hz ★ 0 Hz

Function: _____
 Using this parameter you can set a value for when alarm must be given for f_{LOW} within the normal operational range of the VLT frequency converter.

Description: _____
 If the output frequency falls below the warning limit f_{LOW} , the display shows: LOW FREQ ALARM. You can also choose to program the signal outputs in parameters 408 and 409 to give a signal.

■ 211 Warning: frequency high (HI FREQ WARN)

Value: _____
 0 - 500 Hz ★ 120 Hz

Function: _____
 Using this parameter you can set a value for when alarm must be given for f_{HIGH} within the normal operational range of the VLT frequency converter.

Description: _____
 If the output frequency exceeds the warning limit f_{HIGH} , the display shows: HI FREQ ALARM. You can also choose to program the signal outputs in parameters 408 and 409 to give a signal.

■ 213 Warning: current high (HI CURR WARN)

Value: _____
 0.0 - $I_{VLT,MAX}$ ★ $I_{VLT,MAX}$

Function: _____
 Using this parameter you can set a value for when alarm must be given for I_{HIGH} within the normal operational range of the VLT frequency converter.

Description: _____
 If the output current exceeds the warning limit I_{HIGH} the display shows: HI CURR ALARM. You can also choose to program the signal outputs in parameters 408 and 409 to give a signal.

■ 215 Ramp-up time 1 (RAMP UP TIME)

Value: _____
 0.1 - 800 seconds ★ 5 s

Function: _____
 Using this parameter you can record the required acceleration time from 0.1 Hz to the rated output frequency (parameter 105).

Description: _____
 To ensure the fastest possible start, choose a value for the ramp-up time so that the current limit is not activated. The ramp-up time is always defined as the acceleration time from 0 Hz to the rated motor frequency.

■ 216 Ramp-down time 1 (RAMP DOWN TIME)

Value: _____
 0.1 - 800 seconds ★ 5 s

Function: _____
 Using this parameter you can record the required deceleration time from rated output frequency to 0 Hz.

Description: _____
 The ramp-down time can be selected in the range 0.1-800 seconds. If the ramp-down time is too short the VLT's voltage limit becomes active, which will extend the ramp-down time. Short ramp-down times will require a VLT unit with a brake function and installation of a brake resistor. The ramp-down time is always defined as the deceleration time from the rated motor frequency to 0 Hz.

■ 218 Quick stop ramp (ALT: DOWN RAMP)

Value: _____
 0.1 - 800 seconds ★ 1 s

Function: _____
 Using this parameter you can choose an alternative deceleration ramp - a programmable quick stop ramp.

Description: _____
 The ramp-down time can be selected in the range 0.1-800 seconds, calculated from the rated frequency to 0 Hz. If the ramp-down time is too short the VLT's voltage limit becomes active, which will extend the ramp-down time. Short ramp-down times will require a VLT unit with a brake function and installation of a brake resistor.

★ = Factory setting. Text in () = Display text. The figures in [] are used in bus communication.

■ 224 Carrier frequency (CARRIER FREQ.)

Value: _____
 2 - 16 kHz ★ 4.5 kHz

Function: _____
 To avoid or reduce motor noise you can increase or reduce the carrier frequency of the frequency converter.

Description: _____
 It is possible to change the carrier frequency between 2 and 16 kHz. The disadvantages of operating at a high carrier frequency are:

- reduced continuous output current, see page 95.
- reduced efficiency.
- higher capacitive leakage current.
- increased RFI radiation from the VLT frequency converter.

See also the derating curve on page 95.

The disadvantages of a too low carrier frequency are a less ideal output current and motor loss.

■ 230 Digital speed up/down (SPEED UP DOWN)

Value: _____

★ Disable (DISABLE)	[0]
Enable (ENABLE)	[1]
Enable and save (ENABLE+STORE)	[2]

Function: _____
 Using this parameter you can make the VLT frequency converter lock the output frequency to the latest indicated speed reference.

Description: _____
 You can choose to have either digital speed up/down (terminal 18/27 and 19) or other speed references. When you have chosen *Enable* you must choose *Speed up* (terminal 18) and *Speed down* (terminal 19) in parameters 402/404 and 403. When *Enable and save* is selected a speed will be saved automatically after 15 seconds so that the unit remembers this frequency after new start-up. The other references will not be active so that the digital references cannot be combined with other references.

■ 300 Brake function (BRAKE OPTION)

Value: _____

★ Not applied (NOT APPLIED)	[0]
Applied (APPLIED)	[1]

Function: _____
 Using this parameter you can inform the VLT frequency converter that a brake function and a brake resistor have been connected. For information on sizing, see page 30.

Description: _____
 Choose *Applied* if you use a brake function and a brake resistor.

■ 306 DC braking time (DC-BRAKE TIME)

Value: _____
 ★ 0 - 60 sec. ★ 0 sec.

Function: _____
 Using this parameter you can record how long the DC braking must be active.

Description: _____
 When you choose the braking time you must consider if you want to maintain the braking torque or if you want to use a stop function. The DC braking time must be ≠ 0 to activate DC braking.

■ 307 DC-brake cut-in frequency (DC-BRK ON FREQ)

Value: _____
 ★ 0 - 500 Hz ★ 1 Hz

Function: _____
 Using this parameter you can record the output frequency at which DC braking must start when ramping down to standstill.

Description: _____
 The cut-in frequency depends on the application. The cut-in frequency must be > 0 to activate DC braking. Instead of using this parameter you can activate DC braking via terminal 27 if a DC braking time and a DC brake voltage have been recorded.

★ = Factory setting. Text in () = Display text. The figures in [] are used in bus communication.

■ 308 DC brake voltage (DC-BRK VOLTAGE)

Value:

0 - 50 V ★ 10 V

Function:

Using this parameter you can record the DC brake voltage for the motor.

Description:

The size of the voltage depends on the motor size. The bigger the motor the lower the DC brake voltage.



Warning: At frequent DC-braking the DC brake voltage should not be too high.

This is to avoid motor overload. The DC brake voltage must be > 0 to activate DCbraking.

■ 309 Reset mode (RESET MODE)

Value:

- ★ Manual reset (MANUAL) [0]
- Auto reset 1 (AUORESET 1) [1]
- Auto reset 5 (AUORESET 5) [5]

Function:

Using this parameter you can choose how you want to reset an alarm.

Description:

If you choose *Manual reset* you must reset the VLT frequency converter via the keyboard or via terminals 19, 27 or 29. The display shows TRIP.

If you choose *Auto reset 1* the VLT frequency converter will automatically try to reset once after alarm. The display shows AUTO START

As long as the display shows AUTOSTART the unit will try to reset every 20 minutes.

If you choose *Auto reset 5* the VLT will automatically try to reset 5 times after alarm. The display shows AUTO START.



Warning: The motor may start without warning, if *Auto reset* selected.

■ 310 Trip delay at current limit (TRIP DLY@C.LIM)

Value:

0 - 60 sec.

★ Infinite at 61

Function:

Using this parameter you can record how long the current limit may be active before trip.

Description:

Record the delay time.



Warning: If you choose *Infinite*, and your load is between 105% and 160%, trip may occur after a given interval.

■ 315 Motor thermal protection (MOTOR THERMAL)

Value:

- ★ Off (PROTECT OFF) [0]
- Only warning (ONLY WARNING) [1]
- Trip (TRIP) [2]

Function:

The VLT frequency converter calculates if the motor temperature exceeds the limits allowed. The calculation is based on 1.16 x rated motor current at rated frequency (parameter 107).

Description:

Choose *Off* if you do not want any display indication of either warning or trip.

Choose *Only warning* if you want display indication for motor overloaded.

You can also program the frequency converter to give a warning signal via the signal outputs (parameters 408 and 409).

Choose *Trip* if you want warning and trip to be displayed.

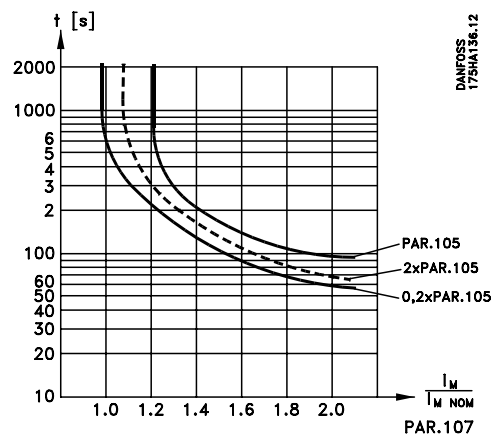

★ = Factory setting. Text in () = Display text. The figures in [] are used in bus communication.

■ 402 Terminal 18 start (INPUT 18)

 Value:

★ Start (START)	[0]
Pulse start (LATCH START)	[1]
No function (NO OPERATION)	[2]
Speed up (SPEED UP)	[3]
Digital reference select (SPEED SELECT)	[4]
Reversing (REVERSING)	[5]
Reset and start (RESET&START)	[6]
Motor coasting and start (COAST/START)	[7]

Reversing:

If the motor reverses when 24 V is applied to terminal 18, it will change direction again when 0 V is applied to the terminal.

Reset and start:

The function can be used as start when terminals 27 and 19 are used to select between the digital references and terminal 29 to change setup (8 digital speeds). 24 V applied to terminal 18 resets the VLT frequency converter and the motor ramps up to the set reference according to the ramp-up time set in parameter 215.

 Function:

Using this parameter (terminal 18) you can give the motor various start signals.

 Description:

Start:

24 V on terminal 18 will make the motor ramp up to the set reference. 0 V will make the motor ramp down to stop.

Motor coasting and start:

24 V applied to terminal 18 makes the motor ramp up to the set reference.

0 V applied to terminal 18 sets the motor to coasting, running freely until it stops. This can be used in connection with a mechanical brake.

Pulse start:

On selection of *Press cont.* in parameter 402 and application of a pulse (24 V) to terminal 18, the motor will ramp up to the set reference. Further pulses do not have any effect. Therefore the motor must be stopped via terminal 27 (parameter 404)

No function:

Locks the input.

Speed up:

This is used together with parameter 230. It is possible to make the output frequency increase towards f_{MAX} as long as 24 V is applied to terminal 18. At 0 V on terminal 18 the output frequency in question is maintained. See also parameter 403.

Digital reference select:

Together with parameter 403 you can choose between four different digital references:

18/27	19	Terminal
0	0	Digital reference 1
1	0	Digital reference 2
0	1	Digital reference 3
1	1	Digital reference 4

★ = Factory setting. Text in () = Display text. The figures in [] are used in bus communication.

403 Terminal 19 reversing (INPUT 19)

Value:

★ Reversing (REVERSING)	[0]
Start reversing (LATCH START)	[1]
No function (NO OPERATION)	[2]
Speed down (SPEED DOWN)	[3]
Digital reference select (SPEED SELECT)	[4]
Reset (RESET)	[5]

Function:

Using this parameter (terminal 19) you can e.g. change the motor's direction.

Description:

Reversing:

Reverses the motor, when 24 V is applied to terminal 19 and changes the rotation direction again when 0 V is applied to the terminal.

Start reversing:

Reverses the motor, when 24 V is applied to terminal 19. The motor stops when 0 V is applied to the terminal.

No function:

Locks the input.

Speed down:

This is used together with parameter 230. It is possible to make the output frequency drop towards f_{MIN} , as long as 24 V is applied to terminal 19. At 0 V applied to terminal 19, the output frequency in question is maintained. See also parameter 402.

Digital reference select:

Together with parameter 402 you can choose between four different digital references:

18/27	19	Terminal
0	0	Digital reference 1
1	0	Digital reference 2
0	1	Digital reference 3
1	1	Digital reference 4

Reset:

In case of alarm the VLT frequency converter can be reset by applying 24 V to terminal 19.

404 Terminal 27 stop (INPUT 27)

Value:

Motor coasting (MTR.COASTnot)	[0]
Quick stop (Q-STOPnot)	[1]
DC-brake (DC-BRAKEnot)	[2]
★ Reset and motor coasting (RESET&COASTnot)	[3]
Stop (STOPnot)	[4]
Reset and start (RESET&START)	[5]
Speed up (SPEED UP)	[6]
Digital reference select (SPEED SELECT)	[7]

Function:

Using this parameter (terminal 27) you can give the motor various stop signals.

Description:

Motor coasting:

If 0 V is applied to terminal 27 the motor will be coasting until standstill.

Quick stop:

If 0 V is applied to terminal 27 the motor will be braking until standstill according to the ramp-down time set in parameter 218.

A DC current brakes the motor after ramping down to 0, according to the setting of parameters 306-308.

DC brake:

If 0 V is applied to terminal 27 the motor will brake to standstill according to the settings of parameters 306 and 308.

Reset and motor coasting:

If 0 V is applied to terminal 27 the motor will start coasting and the VLT frequency converter is reset.

Stop = press:

A circuit breaker between terminals 12 and 27. When opened briefly this circuit breaker causes ramp-down to stop.

Reset and start:

This can be used as a start function when you use terminals 18 and 19 to select a digital reference. 24 V applied to terminal 27 will make the frequency converter reset and the motor ramp up to the set reference according to the ramp-up time set in parameter 215.

(continued overleaf)

★ = Factory setting. Text in () = Display text. The figures in [] are used in bus communication.

■ 404 Terminal 27 stop (INPUT 27) (continued)

Value:

Motor coasting (MTR.COASTnot)	[0]
Quick stop (Q-STOPnot)	[1]
DC-brake (DC-BRAKEnot)	[2]
★ Reset and motor coasting (RESET&COASTnot)	[3]
Stop (STOPnot)	[4]
Reset and start (RESET&START)	[5]
Speed up (SPEED UP)	[6]
Digital reference select (SPEED SELECT)	[7]

Speed up:

This is used together with parameter 230. It is possible to make the output frequency increase towards f_{MAX} as long as 24 V is applied to terminal 18. At 0 V on terminal 18 the output frequency in question is maintained. See also parameter 403.

Digital reference select:

Together with parameter 402 you can choose between four different digital references:

18/27	19	Terminal
0	0	Digital reference 1
1	0	Digital reference 2
0	1	Digital reference 3
1	1	Digital reference 4

■ 405 Terminal 29 Jog (INPUT 29)

Value:

★ Jog (JOG)	[0]
Start (START)	[1]
Digital reference (DIG.REF+START)	[2]
Pulse input, 100 Hz (PULSES 100 Hz)	[3]
Pulse input, 1 kHz (PULSES 1 kHz)	[4]
Pulse input, 10 kHz (PULSES 10 kHz)	[5]
Setup select (SETUP SELECT)	[6]
Reset (RESET)	[7]
Reversing (REVERSING)	[8]
Speed down (SPEED DOWN)	[9]

Function:

Using this parameter (terminal 29) you can give the motor different signals.

Description:

You can set the output frequency to a pre-programmed value (jog in parameter 203). Recording *Digital reference* you can enable/disable values stored in parameters 205-208.

If terminal 29 is used for either pulse signal reference (open loop) or pulse signal feedback (closed loop), choose one of the pulse inputs [3] - [5].

If *Multi setup* is selected in parameter 001, the terminal can be used to switch between setups 1 and 2.

★ = Factory setting. Text in () = Display text. The figures in [] are used in bus communication.

408 Terminal 46 output (LOG.OUTPUT 46)

Value:

Unit ready (UNIT READY)	[0]
★ Unit ready remote control (UNT RDY CRTL)	[1]
Enabled no warning (ENABLEDnoWR)	[2]
Running (RUNNING)	[3]
Running no warning (RUNNINGnoWR)	[4]
Running in range no warning (RNinRGenoWR)	[5]
Speed = reference no warning (RUN@REFnoWR)	[6]
Alarm (ALARM)	[7]
Alarm or warning (ALARMorWARN)	[8]
Current limit (CURRENT LIMIT)	[9]
Out of frequency range (OUT FRQ RGE)	[10]
Out of current range (OUT CURR RGE)	[11]
Reversing (REVERSING)	[12]
Pulse output 15 Hz - 1.5 kHz (PULSOUT 1500)	[13]
Pulse output 15 Hz - 3.0 kHz (PULSOUT 3000)	[14]
Pulse output 15 Hz - value in parameter 005 (PULS-PAR 005)	[15]
Send/receive RS 485 (SEND/REC NEG)	[18]
Receive/send RS 485 (SEND/REC POS)	[19]

Function:

Using this parameter you can choose between different output signals. The output is an open collector output and therefore a pull-up resistor must be connected to terminal 12 (+24 V).

Description:

For the pulse output the lowest output frequency is 15 Hz and the highest output frequency is 5 kHz. RS 485 send/receive control is used when the serial port is connected to the RS 485 network via a RS 232/RS 485 adapter.

Connection example where the signal is active high:

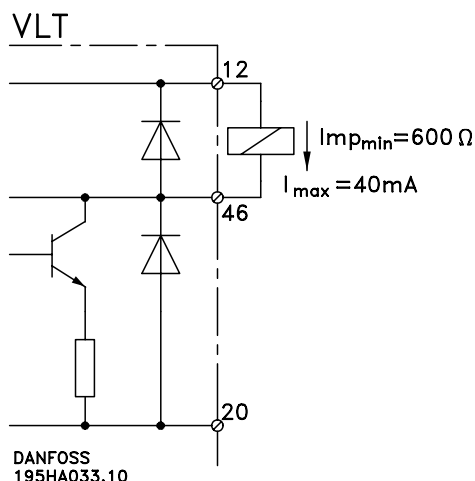

Connection example where the signal is active low:

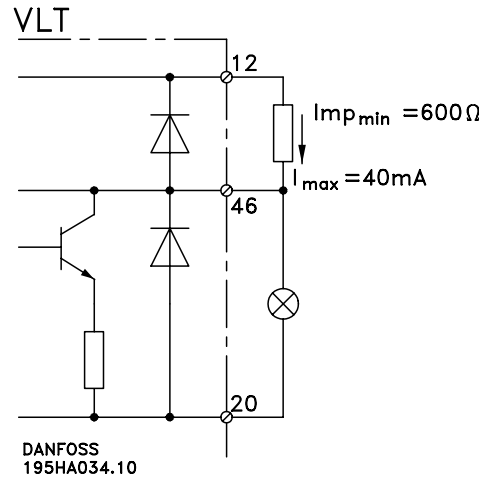

Connection example using RS 232/485 adapter:

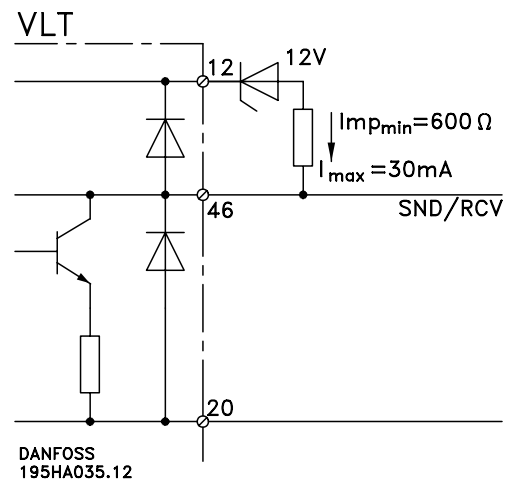

★ = Factory setting. Text in () = Display text. The figures in [] are used in bus communication.

■ 409 Terminal 01
Relay output (RELAY OUT 01)

Value:

★ Unit ready (UNIT READY)	[0]
Unit ready remote control (UNT RDY CRLT)	[1]
Enabled no warning (ENABLEDnoWR)	[2]
Running (RUNNING)	[3]
Running no warning (RUNNINGnoWR)	[4]
Running in range no warning (RNinRGenoWR)	[5]
Running on reference no warning (RUN@REF noWR)	[6]
Alarm (ALARM)	[7]
Alarm or warning (ALARMorWARN)	[8]
Current limit (CURRENT LIM)	[9]
Out of frequency range (OUT FRQ RGE)	[10]
Out of current range (OUT CURR RGE)	[11]
Reversing (REVERSING)	[12]

Description:

You can use the relay output 01 to indicate selected status and warnings. The relay is activated when the conditions for the selected data values are fulfilled. When relay output 01 is not active, there is no connection between terminal 01 and terminal 02. The relay output is potential-free and the maximum load is 2 A at 24 V DC or 250 V AC.

■ 411 Analogue input current (ANALOG REFTYPE)

Value:

★ Linear between min. and max. (LINEAR)	[0]
Proportional with lower limit (PROP W/MIN)	[1]

Function:

Is used to determine which frequency converter is to follow an analogue reference signal.

Description:

When you select [1] the reference signal will not affect the output frequency until it reaches a value equivalent to the set minimum frequency (parameter 201).

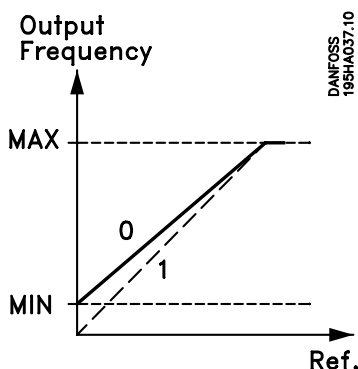
■ 412 Terminal 53
Analogue input voltage (INPUT #53)

Value:

No function (NO OPERATION)	[0]
★ 0-10 V (0-10 VDC)	[1]
10-0 V (10-0 VDC)	[2]

Description:

Record the polarity of analogue control signals to inputs 53 and 60. You can choose between voltage, current and polarity.

If you use both inputs for reference signals the total reference signal will be a summation.

■ 413 Terminal 60
Analogue input current (INPUT #60)

Value:

No function (NO OPERATION)	[0]
★ 0-20 mA (0-20 mA)	[1]
4-20 mA (4-20 mA)	[2]
20-0 mA (20-0 mA)	[3]
20-4 mA (20-4 mA)	[4]

Description:

If you are using a PI controller one of the inputs or the pulse input must be used for the feedback signal. If you are using current control, one of the inputs must be used to set a current limit.

Naturally these choices block the same type of reference signal.

★ = Factory setting. Text in () = Display text. The figures in [] are used in bus communication.

■ **500 Address (ADDRESS)**

Value:

- 01- 99 ★ 01
- 101- 199 (01-99 echo)

Function:

Using this parameter you set the bus address for each VLT via the control panel. However, the first telegram after the voltage connection can change the bus address. This means that address change from the bus is no longer possible.

The echo function enables connection of several VLT 2000 frequency converters to the same PC.

Description:

Specify an address of each unit connected. If the PC/PLC addresses 00, all drives connected will be written to at the same time. The units will in this case not give a reply to the master.

Address change via bus enables address change on units without display.

The echo function is active on address 101-199, shown as 01-99 ECHO. The ring is built up by connecting Tx on the first VLT to Rx on the next VLT.

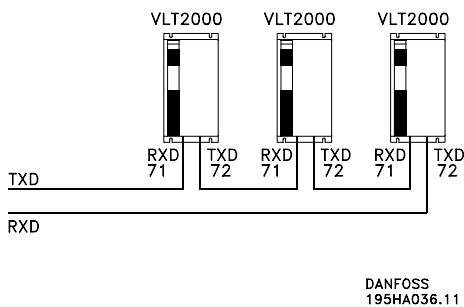

The last unit's Tx is connected to Rx on the PC. Terminal 20 (frame) must be connected throughout, but with the PC connected at only one end.

■ **501 Bit/sec. baud rate (BAUD RATE)**

Value:

- 300, 600, 1200, ★ 1200

Function:

Using this parameter you can set the speed at which a character is transmitted via the RS 232 port. It is defined as the number of bits transmitted per second.

Description:

The transmission rate of the VLT frequency converter must be set in accordance with the transmission rate of the PLC/PC applied. The transmission rate can only be altered via the control panel.

■ **502 Data readout (DATA READOUT)**

Value:

- ★ [0] Reference (REFERENCE %) %
- [1] Frequency (FREQUENCY Hz) Hz
- [2] Display/Feedback (FEEDBACK UNIT) ... "unit"
- [3] Current (CURRENT) A
- [4] Torque (TORQUE %) %
- [5] Power (POWER kW) kW
- [8] Output voltage (OUT VOLT) V
- [9] DC voltage (DC BUS) V
- [10] Motor thermal load (RTR (M)) %
- [11] VLT therm ETR (INVERT THERM) %.
- [12] Digital input (DIG. IN/CODE) binary code
- [13] Analogue input 1 (ANALOGUEin1) in terminal 53
- [14] Analogue input 2 (ANALOGUEin2) in terminal 60
- [15] Warning parameter (WARNING CODE) binary code
- [16] Control word (CONTROL WORD) - see page 57.
- [17] Status word (STATUS WORD) - see page 56.
- [18] Alarm parameter (ALARM CODE) binary code
- [19] Software version no. 4 digits

Description:

Menu 502 can only be selected from the bus. These values are read-only values.

The PC/PLC may prompt for a value from an index between 0 and 19.

★ = Factory setting. Text in () = Display text. The figures in [] are used in bus communication.

Warning parameter messages [15]:

Frequency low re parameter 210	value: 32768
Frequency high re parameter 211	value: 16384
Current limit, re power section	value: 8192
Key blocked	value: 2048
Motor overload	value: 1024
Inverter overload	value: 512
Outside frequency range	value: 256
Current higher than para. 213	value: 128
Data locked	value: 64
Read only	value: 32
Current limit re control card	value: 16
Overvoltage	value: 8
Undervoltage	value: 4
Can only be changed in stop mode	value: 2
Parameter limit	value: 1

Usually only one warning occurs at a time, so one of the figures in parameter 502, index 15, will show. In the event of several simultaneous warnings, e.g. Motor overload and Current limit, re control card, the two values are added:

Inverter overload	512 +
Current limit re control card	16

Reading in para. 502, index 15: 528

Alarm parameter messages [18]:

Excess temperature, re power section	value: 16384
Earth connection	value: 4096
Overvoltage	value: 1024
Undervoltage	value: 512
Unspecified inverter fault	value: 256
Inverter overload	value: 128
Motor overload	value: 64
Short circuit	value: 16
VLT attempts restart	value: 8
Overcurrent	value: 4
Trip locked	value: 1

In contrast to warnings, alarms will always be combined, i.e. at least 2 of the alarm parameters apply, e.g. Unspecified inverter fault will usually occur with another alarm, e.g. Inverter overload. It will give the following reading:

Unspecified inverter fault	256 +
Inverter overload	128

Reading in para. 502, index 18: 384

In case of Short circuit, Earth connection and Excess temperature, re power section, Trip locked will also occur. This will give a typical reading:

Earth connection	4096 +
Unspecified inverter fault	256 +
Trip locked	1

Reading in para. 502, index 18: 4353

■ 503 Coasting (COAST)

Value:	
Digital (DIGITAL)	[0]
Bus (BUS)	[1]
Logical and (AND)	[2]
★ Logical or (OR)	[3]

Description:

See parameter 510

■ 504 Q stop (Q-STOP)

Value:	
Digital (DIGITAL)	[0]
Bus (BUS)	[1]
Logical and (AND)	[2]
★ Logical or (OR)	[3]

Description:

See parameter 510.

■ 505 DC brake (DC-BRAKE)

Value:

Digital (DIGITAL)	[0]
Bus (BUS)	[1]
Logical and (AND)	[2]
★ Logical or (OR)	[3]

Description:
See parameter 510.

■ 506 Start (Start)

Value:

Digital (DIGITAL)	[0]
Bus (BUS)	[1]
Logical and (AND)	[2]
★ Logical or (OR)	[3]

Description:
See parameter 510.

■ 507 Direction (DIRECTION)

Value:

★ Digital (DIGITAL)	[0]
Bus (BUS)	[1]
Logical and (AND)	[2]
Logical or (OR)	[3]

Description:
See parameter 510.

■ 508 Reset (RESET)

Value:

Digital (DIGITAL)	[0]
Bus (BUS)	[1]
Logical and (AND)	[2]
★ Logical or (OR)	[3]

Description:
See parameter 510.

■ 509 Setup select (SETUP SELECT)

Value:

Digital (DIGITAL)	[0]
Bus (BUS)	[1]
Logical and (AND)	[2]
★ Logical or (OR)	[3]

Description:
See parameter 510.

■ 510 Speed select (SPEED SELECT)

Value:

Digital (DIGITAL)	[0]
Bus (BUS)	[1]
Logical and (AND)	[2]
★ Logical or (OR)	[3]

Description:
In parameters 503 to 510 you can choose to control the VLT frequency converter via the control unit's terminals (digitally) and or via the bus.

When using *Logical and* and *Bus* values in parameters 503-510, the digital control terminals are either dependent on or overruled by the bus commands.

■ 511 Bus jog 1 (BUS JOG 1)

Value:

0 - 500 Hz	★ 10 Hz
------------	---------

Function:
Parameter 511 has the same function as parameter 203, but is controlled via the RS 232 port. You change over to jog frequency, which is a preset motor speed, by activating the "Jog" key. Using this function you have access to one additional jog frequency.

Description:
For the jog frequency you can choose a value which is lower than f_{MIN} , but cannot be higher than f_{MAX} .

★ = Factory setting. Text in () = Display text. The figures in [] are used in bus communication.

■ 514 Bus bit 4 (BUS BIT 4)

Value:

★ Q stop (Q-STOP)	[0]
DC-brake (DC BRAKE)	[1]

Description:

See parameters 404, 306, 307 and 308.

■ 516 Bus reference (BUS REFERENCE)

Value:

-100.00% - +100.00% ★ 0

Description:

 If you choose *Local reference* in parameter 003 after choosing a bus reference, the bus reference will be transferred to local reference.

■ 517 Store data values (STORE DATA)

Value

★ Off (OFF)	[0]
On (ON)	[1]

Description:

 Setting parameter 517 to *On* stores the downloaded values. Data values will be stored after you have pressed the "Menu" key.

While the unit is storing data, the display will show (SAVE DATA) and flash in line C.

■ 606 Total operation hours (TOTAL OP HRS.)

Description:

See parameter 610

■ 607 Running hours (RUNNING HRS.)

Description:

See parameter 610

■ 608 Number of power-ups (NO. POWERUPS)

Description:

See parameter 610

■ 609 Number of over-temperature (NO. OVERTEMPS)

Description:

See parameter 610

■ 610 Number of over-voltage (NO. OVERVOLTS)

Description:

Information stored by the VLT frequency converter for later analysis.

Parameter 606-607 are only updated every hour.

★ = Factory setting. Text in () = Display text. The figures in [] are used in bus communication.

Chapter 7

- Status messages Page 82
- Alarm messages Page 82
- Warning messages Page 83
- Reset messages Page 83

■ Status messages

UNIT READY

Control card and power section are powered up and OK.



When the VLT frequency converter's output frequency is reduced more quickly than the motor speed (due to inertia) can be changed, the motor will act as a generator. It will send energy back to the VLT and as a result the intermediate circuit voltage will increase.

ENAB STOP

Unit ready and Q stop signal active.

START

Enabled and start signal applied, no or too low reference signal.

RUN OK

Unit is running on reference.

JOGGING

RAMPING



If the warning OVERVOLTAGE is displayed when the speed is reduced, you can increase the ramp-down time. If that is not possible, it may be necessary to activate the dynamic brake function with brake resistor. If the warning occurs in other situations, the problem is due to the mains supply.

■ Alarm messages

The following alarm messages are displayed after the power section of the VLT frequency converter has been disconnected.

Messages	Caused by	Consequence	Reset possible
INVERTER FAULT	Unknown error (not one of those errors mentioned below)		Yes
OVER VOLT	a: Supply voltage too high b: Ramp-down time too short	a: Lower supply voltage b: Increase ramp-down time or activate brake function to avoid overvoltage	Yes
UNDER VOLTAGE	Supply voltage too low or loss of mains phase		Yes
OVER CURRENT	Motor current too high or wrong motor parameter setting	Check motor parameters Use a larger VLT	Yes
GROUND FAULT	Short circuit between VLT power section and ground	Check installation and cable length	No, power off required, then reset
SHORT CIRCUIT	Short circuit between two motor phases	Check installation	No, power off required, then reset
OVER TEMP	VLT temperature too high	Check installation	No, power off required, then reset
OVER LOAD	Load too heavy		Yes, after VLT thermal protection is lower than 100%
MOTOR TRIP	Motor protection		Yes, after VLT motor protection is zero

■ Warning messages

Messages	Caused by	Consequence	Reset possible
CURRENT LIMIT	Over load	VLT decreases speed	--
VOLTAGE HIGH	Regenerative motor operation or supply voltage too high	The power section of the VLT stops within 5 sec.	--
VOLTAGE LOW	Missing phase or low supply	The power section of the VLT stops within 5 sec.	--
INVERT TIME	Inverter overload	At 98.2% load VLT displays the following warning: "INVERTER TIME". At 100% load: "ALARM OVERLOAD"	--
MOTOR TIME	Motor overload VLT operates between 100% and 160% of nominal motor power	VLT operates at least 60 sec. *) depending on the value of the load before the power section of the VLT stops	--
LO FRQ WARN	Output frequency lower than the value in parameter 210	Depending on application Warning only	
HI FRQ WARN	Output frequency higher than the value in parameter 211	Depending on application Warning only	--
HI CUR WARN	Motor current higher than the value in parameter 213	Depending on application Warning only	--

*) The time is reduced at a higher switch frequency.

■ Reset messages

Messages	Caused by	Consequence	Reset
AUTO START	VLT tripped	The VLT attempts to restart	--
TRIP	Fault condition of the VLT or the motor	The power section of the VLT stops	Yes
TRIP LOCKED	Fault condition (over temp., short circuit, ground fault) of the VLT	The power section of the VLT stops	No, power off required, then reset

Chapter 8

■ CE-labelling	Page 86
■ EMC	Page 86
■ EMC test results	Page 90
■ Emission	Page 90
■ Immunity	Page 91
■ Acoustic noise	Page 92
■ Motor noise	Page 92
■ Extreme running conditions	Page 92
■ Air humidity	Page 93
■ Efficiency	Page 93
■ du/dt measurements	Page 94
■ Derating for high ambient temperature	Page 94
■ Derating for air pressure	Page 95
■ Derating for running at low speed	Page 95
■ Derating for higher switching frequency than 4.5 kHz	Page 95
■ Cut-in current	Page 96

■ What is CE labelling?

The purpose of CE labelling is to avoid technical obstacles to trade within EFTA and the EU. The EU has introduced the CE labelling as a simple way of showing whether a product complies with the

relevant EU directives. The CE mark says nothing about the quality or specifications of a product. Three EU directives relate to frequency converters.

■ The machine directive (89/392/EEC)

All machines with critical, moving parts are covered by the machine directive. Since a frequency converter is largely electrical by function, it does not fall under the machine

directive. However, if a frequency converter is supplied for use in a machine, we will provide information about the safety aspects relating to the frequency converter. We do that by the use of a manufacturer's declaration.

■ The low-voltage directive (73/23/EEC)

Frequency converters must be CE labelled in accordance with the low-voltage directive.

The directive applies to all electrical equipment and appliances used in the voltage range of 50-1000 V AC and 75-1500 V DC.

■ The EMC directive (89/336/EEC)

EMC is short for electromagnetic compatibility. The presence of electromagnetic compatibility means that the mutual interference between different components/appliances is so small that the functioning

of the appliances is not affected. The EMC directive came into force on 1 January 1996. The directive distinguishes between components, appliances, systems and installations.

The EU "Guidelines on Application of Council Directive 89/336/EEC" outline three typical situations of using a frequency converter. For each of these situations, explanations are offered as to whether the situation in question is covered by the EMC directive and must be CE labelled.

1. The frequency converter is sold directly to the final consumer. The frequency converter is for example sold to the domestic market. The final consumer is a layman. He installs the frequency converter himself for example for a hobby machine or a household machine. The frequency converter must be CE labelled according to the EMC directive.
2. The frequency converter is sold for installation in a plant being built up on site by a professional installer. That could for example be a production plant or a heating/ventilation plant, which is designed and installed by professionals. Neither the frequency converter nor the complete plant has to be CE labelled according to the EMC directive. The plant, however, must comply with the basic EMC requirements of the directive. The installer can ensure this by using components, appliances and systems, which are CE-labelled according to the EMC directive.

3. The frequency converter is sold as part of a complete system. A system has an intrinsic function for the final user and is placed on the market as a single functional unit. That could for example be an air-conditioning system. The complete system must be CE labelled according to the EMC directive. The manufacturer of the system can ensure the CE labelling according to the EMC directive either by using CE labelled components or by testing the EMC performance of the system.

If he chooses to use only CE labelled components, he does not have to test the entire system.

■ Danfoss VLT frequency converter and CE labelling

CE labelling is a positive feature when used for its original purpose, ie. to facilitate trade within the EU and EFTA.

However, CE labelling may cover many different specifications. This means that it has to be checked what a given CE label specifically covers.

The specifications covered can in fact be widely different. That is why the CE label can give installers a false feeling of security when using a frequency converter as a component in a system or an appliance.

We CE label our VLT frequency converter in accordance with the low-voltage directive. This means that as long as the frequency converter is installed correctly, we guarantee that it complies with the low-voltage directive. We issue a declaration of conformity confirming that our CE label complies with the low-voltage directive.

The CE mark also applies to the EMC directive, on condition that the instructions given in the manual for EMC correct installation and filtering are followed. On that basis a declaration of conformity with the EMC directive is issued.

To help ensure that your installation is EMC-correct, the manual provides detailed instructions for installation. Furthermore, we specify which norms that are complied with by which of our products.

We offer the filters that can be seen from the specifications and gladly provide other types of assistance that can help you obtain the best EMC result.

■ Compliance with EMC directive 89/336/EEC

In support of our claim that the VLT frequency converter complies with the protection requirements for emission and immunity under EMC directive 89/336/EEC, a Technical Construction File (TCF) has been prepared for each model. Such a file defines the EMC requirements and the measurements made in accordance with harmonised EMC standards in a Power Drive System (PDS) that consists of a VLT frequency converter, a control cable and the controls (control box), motor cable and motor plus any options added. The Technical Construction File is prepared on this basis in cooperation with a duly authorised EMC laboratory (Competent Body).

In most cases the VLT frequency converter is used by professionals of the trade as a complex component forming part of a larger appliance, system or installation. It must be noted that the responsibility for the final EMC properties of the appliance, system or installation rests with the installer. As an aid to the installer, Danfoss has prepared EMC installation guidelines for the Power Drive System. The standards and testing levels stated for the Power Drive System are complied with, provided that the EMC-correct installation guidelines are applied.

■ Earthing

The following basic issues need to be considered when installing a frequency converter, so as to obtain electromagnetic compatibility (EMC).

Safety earthing:

Please note that the frequency converter has a high leakage current and must be earthed appropriately for safety reasons. Apply local/national safety regulations. Use terminal 95 for reinforced earthing.

High frequency earthing:

Keep the earth wire connections as short as possible. Connect the different earth systems at the lowest possible conductor impedance.

The lowest possible conductor impedance is obtained by keeping the conductor as short as possible and by using the greatest possible surface area.

A flat conductor, for example, has a lower HF impedance than a round conductor for the same conductor square value.

If more than one appliance is installed in cabinets, the cabinet rear plate, which must be made of metal, should be used as a common earth reference plate. The metal cabinets of the different appliances are mounted on the cabinet rear plate using the lowest possible HF impedance. This avoids having different HF voltages for the individual appliances and avoids the risk of radio interference currents running in connection cables that may be used between the appliances. The radio interference will have been reduced.

■ Cables

The control cable and the filtered mains cable should be installed separately from the motor and brake cables to prevent interference coupling. Normally, a distance of 20 cm will be sufficient, but it is recommended to keep the greatest possible distance wherever possible, especially where cables are installed in parallel over a substantial distance.

With respect to sensitive signal cables such as telephone cables and data cables, the greatest possible distance is recommended with a minimum of 1 per 5 m of power cable (mains, motor and brake

cable). It must be pointed out that the necessary distance depends on the sensitivity of the installation and the signal cables, and that therefore no precise values can be stated.

If cable trays are used, sensitive signal cables are not to be placed in the same cable trays as the motor cable or brake cable.

If signal cables are to cross power cables, this should be done at an angle of 90 degrees.

Remember that all interference-carrying in- or outgoing cables to/from a cabinet should be screened or filtered.



The cables must throughout their length be reinforced/double-isolated to other cables.

■ Radio interference in general (emission)

Electrical interference from the cable network, cable-borne interference, 150 kHz-30 MHz, and airborne interference from the drive system, 30 MHz-1 GHz, is produced in particular by the inverter, the motor cable and the motor system for frequencies under approx. 50 MHz.

As the sketch below shows, capacitive currents in the motor cable together with high du/dt from the motor voltage will produce interference.

Use of screened motor cable increases the leakage current. This is because screened cables have higher capacitance to earth than unscreened cables. If the leakage current is not filtered, it will cause greater interference on the mains in the radio leakage range under approx. 5 MHz. Since the leakage current is carried back to units through the screen, in principle this will give only a small electromagnetic field from the screened motor cable.

The screen reduces the radiated interference, but increases the low frequency interference on the mains.

With regard to installation, it is generally less complicated to use unscreened cables than screened cables. For VLT 2000 an RFI and motor filter as well as a LC and RFI filter have been developed making it possible to observe the EMC emission requirements when unscreened motor cables are used. The motor filter reduces the leak current I_1 (see figure below). VLT 2000 frequency converters with built-in RFI filter and without motor coils fulfil the EMC emission requirements.

In order to reduce the interference level from the system overall (unit + installation) as far as possible, it is important to make motor and brake cables as short as possible.

Cables with a sensitive signal level may not be led together with motor and brake cables.

Radio interference higher than 50 MHz (airborne) will particularly affect the control electronics.

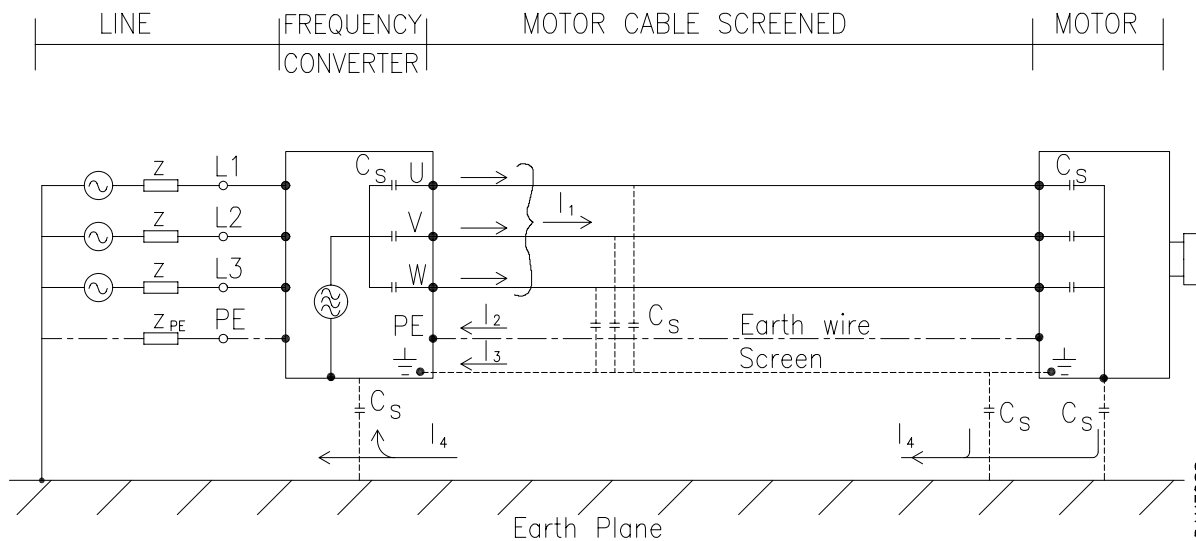

DANFOSS
175HA179.12

■ EMC test results
■ Emission

Subsequent test results have been obtained using a system with a VLT frequency converter (with RFI filter module) a screened control cable and control box with potentiometer, unscreened motor cable and motor.

Standard	Port	VLT 2000 type		VLT 2000 type		VLT 2000 type	
		2010-2030	208-240 V	2040-2050	208-240 V	2020-2060	380-460 V
EN 55011 gr.1 Class A	Line 150 KHz - 30 MHz	yes ¹		no ^{2,3}		yes ^{1,4}	
EN 55011 gr.1 Class A	Enclosure 30 MHz - 1 GHz	yes ¹		no ^{2,3}		yes ^{1,4}	

- ¹ Using RFI and motor filter for unscreened motor cable. Max.100 m, see page 88.
- ² RFI and motor filter not available for VLT 2040-2050, 3 x 208-240 V
- ³ VLT 2040-2050, 3 x 208-240 V are not available with built-in RFI filter.
- ⁴ VLT 2000 up to 415 V versions are available with built-in RFI filter.

With the purpose of minimising the cable-conducted interference to the mains supply and the radiated interference from the frequency converter system, the motor cables should be kept as short as possible. According to experience, most installations represent only a slight risk of any interference from radiation.

■ Immunity

In order to document immunity towards interference from electrical phenomena that are coupled in, the following immunity test has been made on a system consisting of a VLT frequency converter (with RFI filter module),

a screened control cable and control box with potentiometer, motor cable and motor.

Fault criteria and test were in accordance with EN 50082-2 and IEC 22G/31/FDIS.

The tests were made using the following standards:

IEC 1000-4-2 (IEC 801-2/1991):
Electrostatic discharges (ESD)

Simulation of electrostatic discharges from human beings.

IEC 1000-4-4 (IEC 801-4):
Burst transients

Simulation of interference brought about by coupling with a contactor, relays or similar devices.

IEC 1000-4-3 (IEC 801-3):
Incoming electromagnetic field radiation

Simulation of the effects of radar and radio communication equipment as well as mobile communication equipment.

IEC 1000-4-5 (IEC 801-5):
Surge transients

Simulation of transients brought about e.g. by lightning that strikes near installations.

SEN 361503
Mains disturbance

Simulation of conducted capacitive interference between control cables and adjacent mains cable.

ENV 50141 (IEC 801-6):
Cable conducted HF

Simulation of the effect of radio transmission equipment coupled to connection cables.

VDE 0160 class W2 testpulse
(draft Oct./1990 yellow):
Mains transients

Simulation of high-energy transients brought about by main fuse breakage, coupling with phase compensation batteries etc.

VLT 2010-2030 1/3x208-240 V, VLT 2040-2050 , 3x208-240 V,
VLT 2020-2060 380-460 V

Basis standard	Burst IEC 1000-4-4		Surge IEC 1000-4-5		Mains freq. test SEN 361503	ESD IEC 1000-4-2	Radiated elec- tromagn. field IEC 1000-4-3	Mains dis- tortion VDE 0160	RF common mode voltage ENV 50141
Acceptance criterion	B		B		A	B	A	-	A
Port connection	CM	DM	CM	CM	CM	-	-	DM	CM
Line	OK	OK	OK	-	-	-	-	OK	OK
Motor	OK	-	-	-	-	-	-	-	OK
Control lines	OK	-	OK	OK	OK	-	-	-	OK
Enclosure	-	-	-	-	-	OK	OK	-	-

Basic specification:

Line	2kV/5kHz/DCN	1kV/2ohm	2kV/12ohm	-	-	-	**2,3 x \hat{U}_N	10V rms
Motor	2kV/5kHz/CCC	-	-	-	-	-	-	10V rms
Control lines	2kV/5kHz/CCC	-	2kV/ 2ohm*	250V/50Hz	-	-	-	10V rms
Enclosure	-	-	-	-	8 kV AD 6 kV CD	10V/m	-	-

Acceptance criteria according to: IEC 22G/31/FDIS, EN 50082-2, 175R0740

DM: Differential mode

CM: Common mode

CCC: Capacitive clamp coupling

DCN: Direct coupling network

AD: Air Discharge

CD: Contact Discharge

* Injection on cable shield

** 2,3 x \hat{U}_N : max. testpulse 1250 V_{PEAK}

■ Acoustic noise

The acoustic noise from the frequency converter is generated from 3 sources:

1. The motor coils (if mounted) generate a 4.5 kHz noise, which is dependent on the cable impedance.
2. The DC coils (if mounted) generate a 100 Hz noise (300 Hz, three-phase), which is proportional with the motor load.

3. The noise from the built-in fan (not integrated in all units) is acceptable to the human ear, although the measurements show the highest values for fan noise.

The values below (sound pressure) have been measured in accordance with VDE 0160.4.2 standard at a distance of 1 metre from the VLT frequency converter at 100% load and rated speed.

VLT type	2010	2015	2020 *)	2030 *)	2040*)	2050*)	2020	2025	2030	2040 *)	2050 *)	2060 *)
IP 20 dB (A)	30.1	30.1	50.7	50.7	50.7	50.7	30.1	30.1	30.1	50.7	50.7	50.7

*) with built-in fan.

■ Motor noise

The motor noise depends mainly on the motor, but as a guideline the noise increases by about 10 dB (A) in relation to direct mains operation.

If a higher switching frequency is chosen the noise from the motor will decrease. How much will depend on the motor resonance and the type of motor.

■ Extreme running conditions
Short circuit

VLT 2000 Series is protected against short circuits. A short circuit between two output phases will cause overcurrent in the inverter. However, each switch of the inverter will be turned off individually when the short circuit current exceeds the permitted value.

Ground fault

In case of an ground fault in a motor phase, the inverter is turned off within 5-10 ms.

Switching on the output (only using motor chokes)

Switching on the output between the motor and the frequency converter is fully permitted. It is not possible to damage the VLT frequency converter in any way by switching on the output, although it may result in some occasional tripping conditions.

Motor-generated overvoltage

The voltage on the intermediate circuit will be increased when the motor acts as a generator. This takes place in two cases:

1. The load runs the motor (at constant output frequency from the frequency converter), i.e. energy is supplied from the load.
2. During deceleration ("ramp-down"), if the moment of inertia is high, the load is low and/or the ramp-down time is short.

The control unit attempts to correct the ramp if possible. The inverter turns off to protect the transistors and the intermediate capacitors, when a certain voltage level is reached.

Mains drop-out

During a mains drop-out the VLT frequency converter will continue to operate until the intermediate circuit voltage drops below the minimum stop level, typically 85% of the VLT frequency converter's rated mains supply voltage.

The time before inverter stop depends on mains voltage before drop-out and the motor load.

Ride-through can be programmed.

Static overload

When the VLT frequency converter is overloaded (the current limit $I_{LIM,i}$ is reached) the control unit will reduce the output frequency f_M in an attempt to reduce the load. If the reduction of the output frequency does not reduce the load, the control unit finally trips when the output frequency has dropped below 1 Hz.

Running at current limit is limited (0-60 sec).

■ Air humidity

The VLT frequency converter has been designed to meet VDE 0160, 5.2.1.2.
Light dew is tolerated on internal insulating surfaces, but not during operation.

■ Efficiency

To reduce energy consumption it is very important to optimise the efficiency of a system. The efficiency of each single element in the system should be as high as possible.

Efficiency of the VLT 2000 Series (η_{VLT})

The load on the frequency converter has little effect on its efficiency. In general the efficiency at rated motor frequency $f_{M,N}$ is the same whether the motor supplies a 100% rated shaft torque or only 75%. The variable switching frequency affects the losses in the VLT 2000 Series. The efficiency will drop a little when the switching frequency is set to a value higher than 4.5 kHz.

Motor efficiency (η_{MOTOR})

The efficiency of a motor connected to the frequency converter depends on the sine shape of the current. In general efficiency is just as good as at mains operation.

The motor efficiency depends on the make of the motor. Normally the motor efficiency drops when the load is lower than the rated torque.

In the range 75-100% of rated torque the efficiency of the motor will be almost constant both when operated by the frequency converter and when running directly on the mains.

In general the internal switching frequency does not affect the efficiency of small motors.

System efficiency (η_{SYSTEM})

To calculate the system efficiency you can multiply the efficiency of the units of the VLT 2000 Series (η_{VLT}) by the efficiency of the motor (η_{MOTOR}) using the below formula:

$$\eta_{SYSTEM} = \eta_{VLT} \times \eta_{MOTOR}$$

■ du/dt measurements

When a transistor in the inverter is activated, the voltage applied to the motor will rise by a flank. The du/dt ratio on the flank is determined by

- Motor cable (type, cross section, length)
- Inductance

The self-inductance will cause an overshoot U_{PEAK} in the motor voltage before it stabilises at a level determined by the voltage in the intermediate circuit. Both the du/dt ratio and the U_{PEAK} peak voltage affect the lifetime of the motor. Too high values will primarily affect motors without phase coil insulation.

With short (a few metres) motor cable, the du/dt ratio will be high but the peak voltage low.

With long (100 metres) motor cable, the du/dt ratio will decrease and the U_{PEAK} peak voltage will increase. If you use very small motors without phase coil insulation we recommend to mount an LC filter in series with the motor.

Typical values for the du/dt ratio and the U_{PEAK} peak voltage measured between two phases (5 m and 275 m screened motor cable) are listed below:

U_{PEAK} [V]

Cable length	5 m	275 m
VLT 2030	464 V	744 V
VLT 2030 with motor coil IP 20	516 V	744 V
VLT 2030 with motor coil IP 00	440 V	628 V

du/dt [V/μs]

Cable length	5 m	275 m
VLT 2030	3727 V/μs	253 V/μs
VLT 2030 with motor coil IP 20	690 V/μs	157 V/μs
VLT 2030 with motor coil IP 00	359 V/μs	93 V/μs

Note: The above measurements are for VLT 2030, 1/3 x 208-240 V installed on single-phased mains

■ Derating for high ambient temperature

The ambient temperature is the maximum temperature allowed. The average over 24 hours must be at least 5 °C lower according to VDE 0160 5.2.1.1.

If the VLT frequency converter is operated at temperatures above 40 °C, then a derating of the output current is necessary.

At higher temperatures, derating will not be possible due to the load-independent temperature on the SMPS transistors.

The derating for VLT 2010-2060

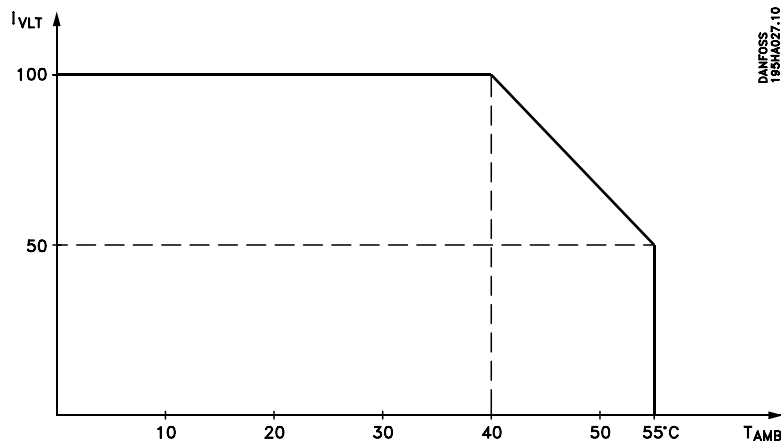

40 °C: 100% output, 45 °C: 84% output, 50 °C: 67% output, 55 °C: 50% output

Derating for air pressure

Below 1,000 metres altitude no derating is necessary.

Above 1,000 metres the T_{amb} or maximum output power must be derated according to the figure below.

Derating for air pressure

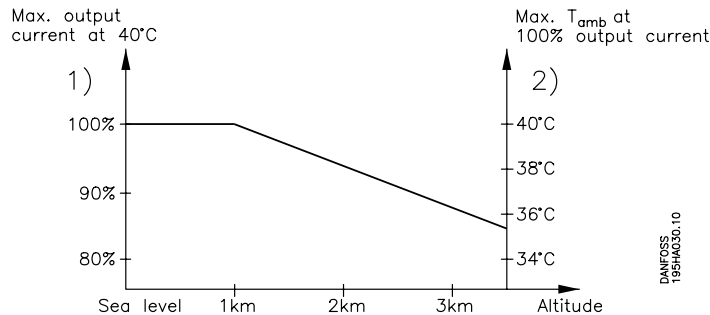

1. Derating of output current versus altitude at T_{amb} 40 °C.
2. Derating of max. T_{amb} versus altitude at 100% output current.

Derating for running at low speed

No derating is necessary when running the motor at rated speed, or when controlling a fan or centrifugal pump.

Motors running at constant load torque (CT) used at low speed must be derated or fan-cooled (see diagram).

Typical motor derating

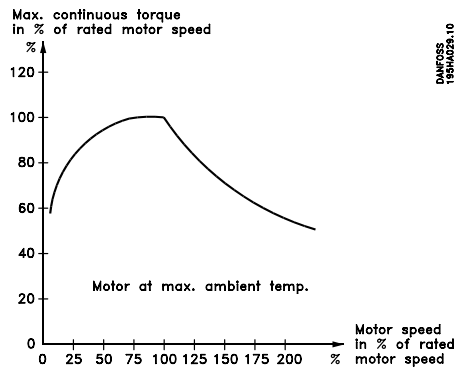

Derating for higher switching frequency than 4.5 kHz

A higher switching frequency means higher losses and increased heat generation in the transistors and motor coils of the frequency converter.

Therefore the VLT frequency converter automatically reduces the maximum continuous output current $I_{VLT,N}$ when the switching frequency exceeds 4.5 kHz. The reduction is done linearly to 60% at 16 kHz (see diagram). The maximum permitted motor cable length is 40 m of screened cable.

Derating for higher switching frequency

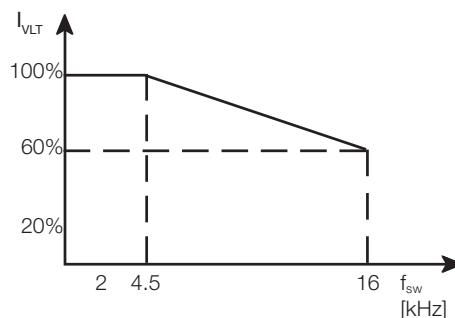

■ Cut-in current

On cutting in the VLT frequency converter to the mains a cut-in current surge occurs. The cut-in current is limited by an NTC resistor. The size of this current surge depends on the mains impedance and the NTC resistor's cooling time since the last cut-in. The current surge can be doubled if the VLT frequency converter is still warm. The cooling time is 100-200 seconds.

Maximum cut-in current surge measured at 25°C:

1 x 220/230/240 V 3 x 208/220/230/240 V	I_{PEAK}	$I^2 \text{ xt}$
VLT 2010 ¹	32 A	4.1 A ² s
VLT 2015 ¹	80 A	15.2 A ² s
VLT 2020 ¹	80 A	26 A ² s
VLT 2030 ¹	160 A	36 A ² s
VLT 2040 ²	16 A	4 A ² s
VLT 2050 ²	16 A	4 A ² s

¹) Single phase installation

²) Three phase installation

3 x 308-460 V	I_{PEAK}	$I^2 \text{ xt}$
VLT 2020	28.8 A	0.11 A ² s
VLT 2025	28.8 A	0.11 A ² s
VLT 2030	94.4 A	14.4 A ² s
VLT 2040	94.4 A	14.4 A ² s
VLT 2050	136 A	25.4 A ² s
VLT 2060	136 A	25.4 A ² s

Chapter 9

- Troubleshooting Page 98
- Your parameter settings Page 102
- Factory settings Page 105

■ Troubleshooting

The fault location procedure is described on the following pages.

A total of 5 symptoms are described in the flow charts.

Should you need any further guidance you are always welcome to contact Danfoss.

■ Service

Danfoss will repair the new VLT 2000 1/3 phase, 230 V and the VLT 2000 3-phase 380-460 V. The service policy is based on replacement of vital parts.

Please contact your nearest distributor for further information.

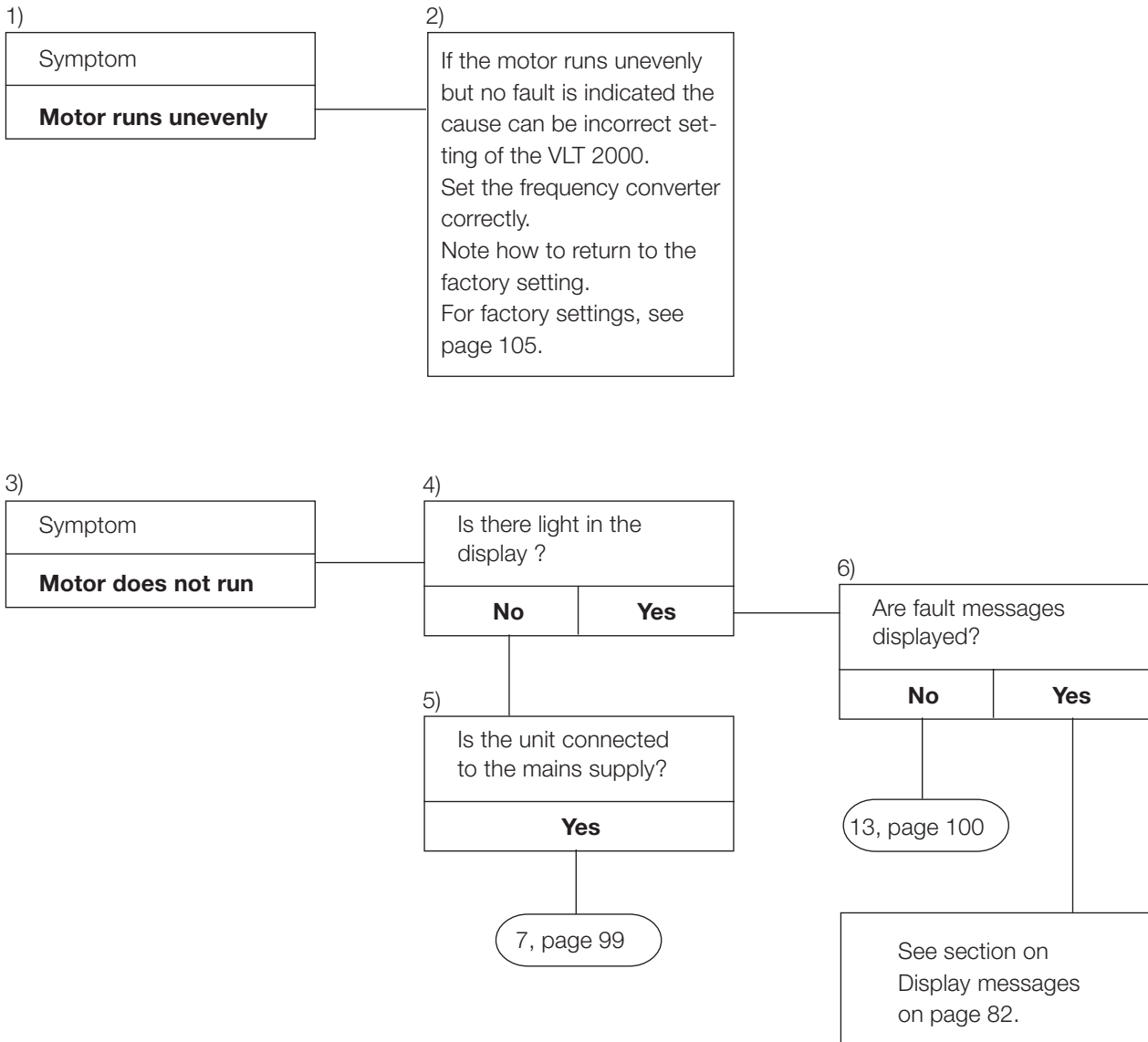

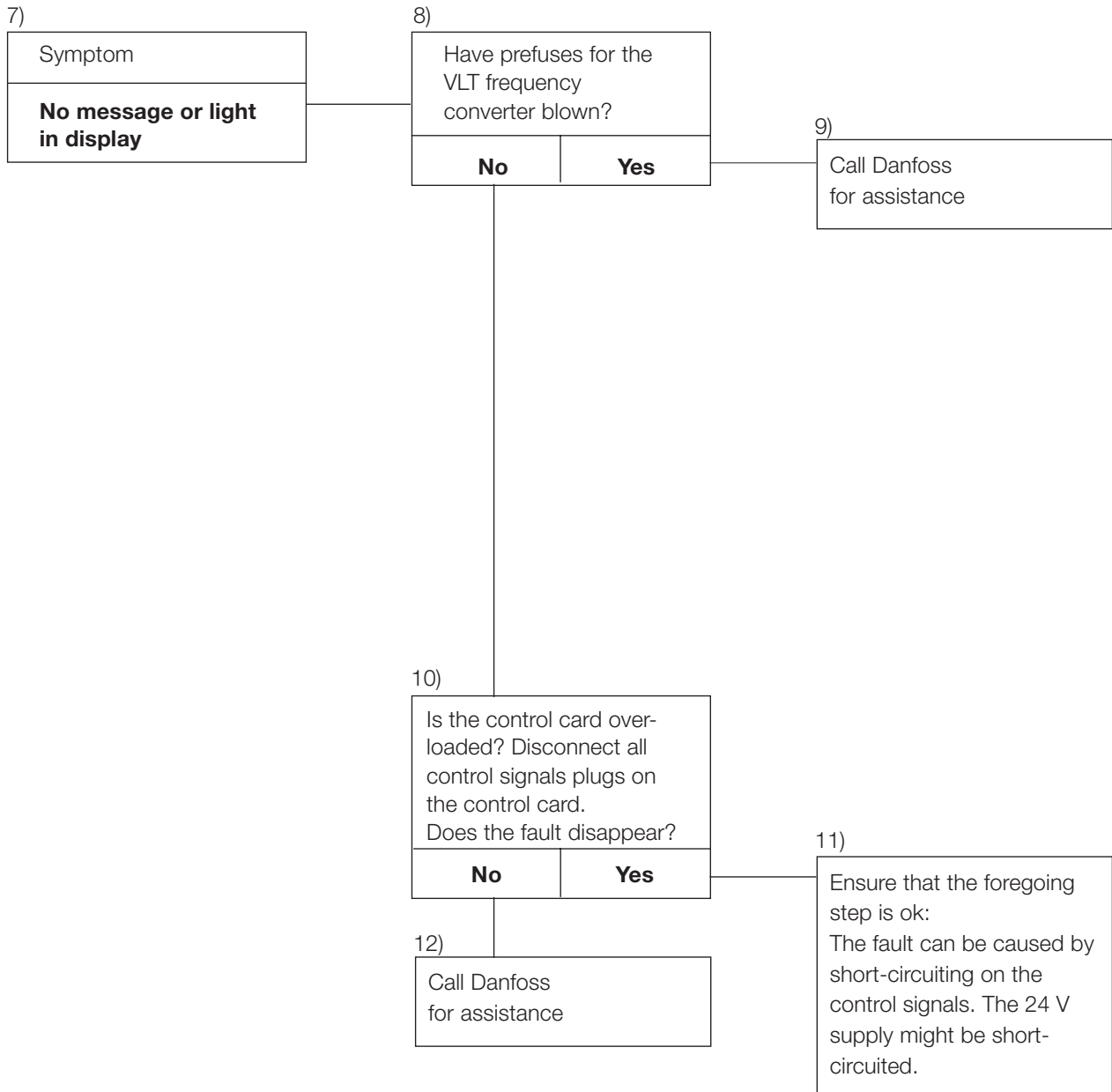

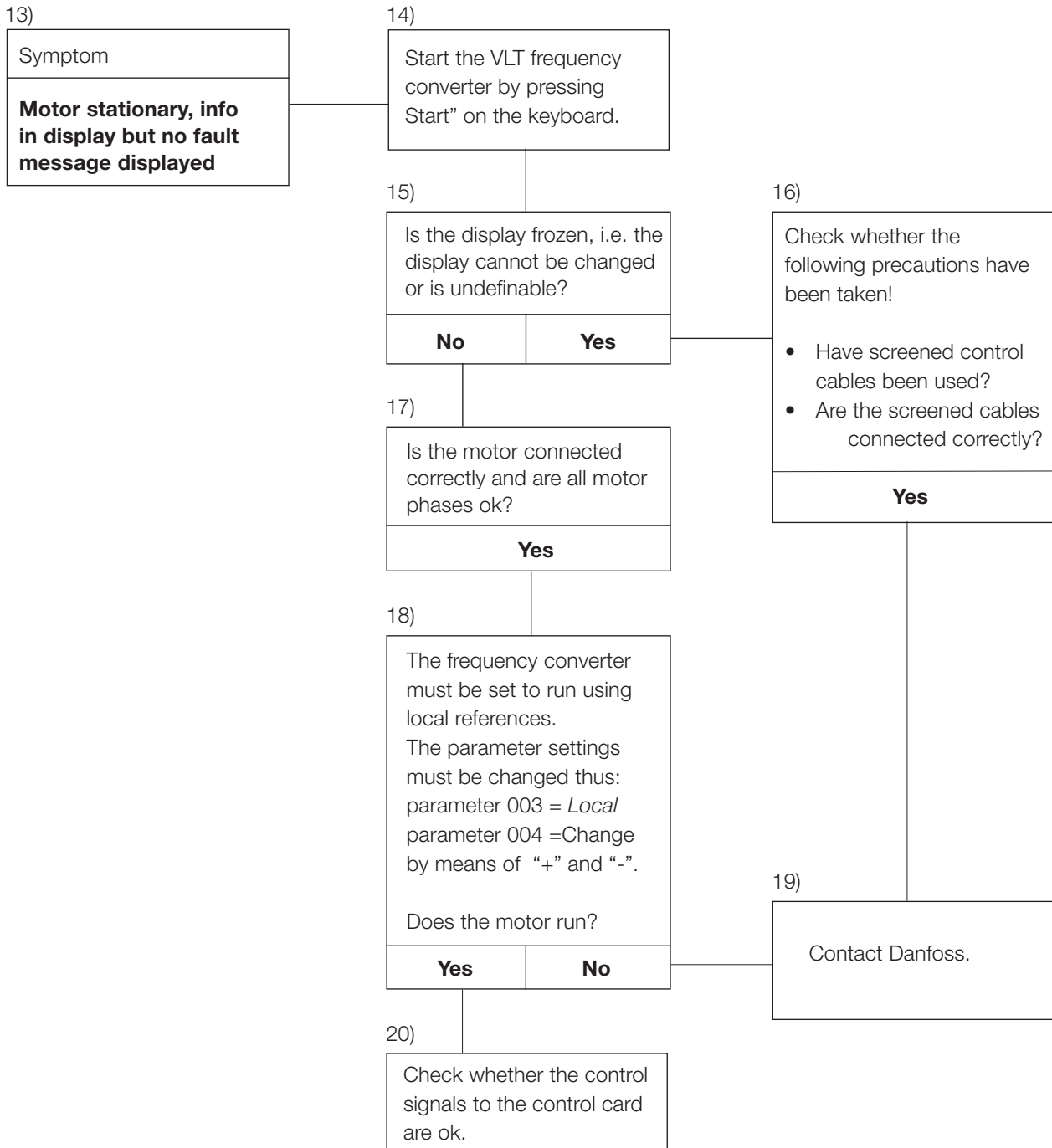

21)

Symptom
VLT frequency converter trips out, OVERVOLTAGE displayed and motor does not run.

22)

Is the brake resistor and the connection to it OK?
Yes

23)

Replace the brake print.

■ Your parameter settings

We recommend you to write down the settings of the various parameters in the forms on the following pages.

You can write down the settings for each of the two setups, which can be programmed in parameter 001. Filled-in forms will give you a quick survey of how your VLT frequency converter is set.

	Setup 1	Setup 2
000 LANGUAGE	X	ENGLISH
		GERMAN
		FRENCH
		DANISH
001 MENU SETUP	X	SETUP 1
		SETUP 2
		MULTI SETUP
002 MENU SET COPY	X	DO NOT COPY
		COPY 1 TO 2
		COPY 2 TO 1
		FACTORY TO 1
		FACTORY TO 2
003 LOCAL REMOTE	X	REMOTE
		LOC EXT.STOP
		LOCAL+REMOTE
004 LOCAL SPEED		HZ
005 VALUE AT MAX		
006 LOCAL RESET		DISABLE
	X	ENABLE
007 LOC START/STOP		DISABLE
	X	ENABLE
008 LOCAL FWD/REV	X	DISABLE
		ENABLE
009 LOCAL JOG		DISABLE
	X	ENABLE
010 LOCAL REFERENCE	X	DISABLE
		ENABLE
013 DATA CHG. LOCK	X	NOT LOCKED
		LOCKED
101 SPEED CONTROL		OPEN LOOP
	X	SLIP COMP.
		CLOSED LOOP
102 CURRENT LIMIT	X	PROGRAM SET
		10 VDC SIGNAL
		20 mA SIGNAL

	Setup 1	Setup 2
103 MOTOR POWER		UNDER SIZE
	X	NOM. SIZE
		OVER SIZE
104 MOTOR VOLTAGE		200 V
		208 V
	X	220 V
		230 V
		240 V
		380 V
	X	400 V
		415 V
		440 V
		460 V
105 MOTOR FREQ.	X	50 HZ
		60 HZ
		87 HZ
		100 HZ
107 MOTOR CURRENT		A
108 MOTOR MAG. AMP.		A

X = factory settings

	Setup 1	Setup 2	
109 START VOLTAGE		V	
110 START COMP.		V/A	
111 V/F RATIO		V/HZ	
112 SLIP COMP		HZ	
114 FEEDBACK TYPE		VOLTAGE 10 V	
	X	CURRENT 20mA	
		PULSES	
119 FEED FWD. FACTR		%	
120 CONTRL RANGE		%	
121 PROPRT/L GAIN			
122 INTEGRAL TIME		SECONDS	
125 FEEDBACK SCALE		%	
200 FREQ RANGE	X	120 HZ	
		500 HZ	
201 MIN. FREQUENCY		HZ	
202 MAX. FREQUENCY		HZ	
203 JOG FREQUENCY		HZ	
204 DIG. REF. TYPE	X	SUM	
		RELATIVE	
205 DIG. REF. 1		%	
206 DIG. REF. 2		%	
207 DIG. REF. 3		%	
208 DIG. REF. 4		%	
209 CURRENT LIMIT		A	
210 LOW FREW WARN.		HZ	
211 HI FREQ WARN.		HZ	
213 HI CURR WARN.		A	
215 RAMP UP TIME		SECONDS	
216 RAMP DOWN TIME		SECONDS	
218 ALT: DOWN RAMP		SECONDS	
224 CARRIER FREQ.		KHZ	
230 SPEED UP/DOWN	X	DISABLED	
		ENABLED	
		ENABLE&STORE	
300 BRAKE OPTION	X	NOT APPLIED	
		APPLIED	
306 DC-BRAKE TIME		SECONDS	
307 DC-BRK ON FREQ		HZ	
308 DC-BRK VOLTAGE		V	
309 RESET MODE	X	MANUAL	
		AUTORESET 1	
		AUTORESET 5	
310 TRIP DLY@C.LIM		SECONDS	
315 MOTOR THERMALX		PROTECT-OFF	
	X	ONLY WARNING	
		TRIP	
402 INPUT 18	X	START	
		LATCH START	
		NO OPERATION	
		SPEED UP	
		SPEED SELECT	
		REVERSING	
		RESET&START	
		COAST/START	

	Setup 1	Setup 2	
403 INPUT 19	X		REVERSING
			LATCH REV
			NO OPERATION
			SPEED DOWN
			SPEED SELECT
			RESET
404 INPUT 27			MTR.COAST
			Q-STOP not
			DC-BRAKE not
	X		RST&COASTnot
			STOP not
			RESET & START
			SPEED UP
			SPEED SELECT
405 INOUT 29	X		JOG
			START
			DIG.REF+START
			PULSES 100 HZ
			PULSES 1 KHZ
			PULSES 10 KHZ
			SELECT SETUP
			RESET
			REVERSING
			SPEED DOWN
408 LOG OUTPUT 46			UNIT READY
	X	X	UNT RDY RCTL
			ENABLEDnoWR
			RUNNING
			RUNNINGnoWR
			RNINRGE noWR
			RUN@REFnoWR
			NO WARNING
			ALARM
			ALARMorWARN
			CURRENT LIM
			OUT FRQ RGE
			OUT CURR RGE
			PULSOUT 1500
			PULSOUT 3000
			PULS-PAR 005
			SEND/REC NEG
			SEND/REC POS

X = factory settings

	Setup 1	Setup 2	
409 RELAY OUT 01	X	X	UNIT READY
			UNT RDY CRTL
			ENABLEDnoWR
			RUNNING
			RUNNING noWR
			RNinRGE noWR
			RUN@REF noWR
			ALARM
			ALARMorWARN
			CURRENT LIM.
			OUT FRQ RGE
		OUT CURR RGE	
		REVERSING	
411 ANALOGUE REF TYPE			LINEAR
			PROP W/MIN
412 INPUT #53			NO OPERATION
	X	X	0-10 VDC
			10-0 VDC
413 INPUT #60			NO OPERATION
	X	X	0-20 mA
			4-20 mA
			20-0 mA
			20-4 mA
500 ADDRESS	X		01
501 BAUD RATE			300
			600
	X		1200
502 DATA READ-OUT			
503 COASTING			DIGITAL
			BUS
			LOGICAL AND
	X		LOGICAL OR
504 Q STOP			DIGITAL
			BUS
			LOGICAL AND
	X		LOGICAL OR
505 D.C. BRAKE			DIGITAL
			BUS
			LOGICAL AND
	X		LOGICAL OR
506 START			DIGITAL
			BUS
			LOGICAL AND
	X		LOGICAL OR
507 DIRECTION	X		DIGITAL
			BUS
			LOGICAL AND
			LOGICAL OR
508 RESET			DIGITAL
			BUS
			LOGICAL AND
	X		LOGICAL OR

	Setup 1	Setup 2	
509 SETUP SELECT			DIGITAL
			BUS
			LOGICAL AND
	X		LOGICAL OR
510 SPEED SELECT			DIGITAL
			BUS
			LOGICAL AND
	X		LOGICAL OR
511 BUS JOG 1			HZ
514 BUS BIT 4	X		Q STOP
			D.C. BRAKE
516 BUS REFERENCE			%
517 STORE DATA	X	X	OFF
			ON
606 TOTAL OP HRS.			
607 RUNNING HRS.			
608 NO. POWERUPS			
609 NO. OVERTEMPS			
610 NO. OVERVOLTS			

X = factory settings

■ Operation and display

000	LANGUAGE ^{§)}	ENGLISH
001	MENU SETUP ^{§)}	SETUP 1
002	MENU SET COPY	DO NOT COPY
003	LOCAL/REMOTE ^{§)}	REMOTE
004	LOCAL ^{§)}	
005	VALUE AT MAX ^{§)}	1000
006	LOCAL RESET ^{§)}	ENABLE
007	LOC START/STOP ^{§)}	ENABLE
008	LOCAL FWD/REV ^{§)}	DISABLE
009	LOCAL JOG ^{§)}	ENABLE
010	LOC REFERENCE ^{§)}	ENABLE
013	DATA CHG.LOCK	NOT LOCKED

■ Load and motor

101	SPEED CONTROL ^{2,§)}	SLIP COMP
102	CURRENT LIMIT ^{§)}	PROGRAM SET
103	MOTOR POWER ²⁾	NOM. SIZE
104	MOTOR VOLTAGE ²⁾	Depending on unit
105	MOTOR FREQ ²⁾	50 Hz
107	MOTOR CURRENT ^{2,§)}	Depending on unit
108	MOTOR MAG.AMP. ^{2,§)}	Depending on unit
109	START VOLTAGE ^{2,§)}	Depending on unit
110	START COMP ^{2,§)}	0
111	U/F RATIO ^{2,§)}	Depending on unit
112	SLIP COMPENSATION ^{2,§)}	Depending on unit
114	FEEDBACK TYPE ^{§)}	CURRENT
119	FEEDFWD FACTR ^{2,§)}	100%
120	CONTRL RANGE ^{2,§)}	100%
121	PROPRT/L GAIN ^{2,§)}	0.01
122	INTEGRAL TIME ^{2,§)}	OFF
125	FEEDBACK SCALE	100%

■ References

200	FREQ RANGE ²⁾	120 Hz
201	MIN. FREQUENCY ^{2,§)}	0
202	MAX. FREQUENCY ^{2,§)}	50 Hz
203	JOG FREQUENCY ^{2,§)}	10 Hz
204	DIG. REF. TYPE ^{§)}	SUM
205	DIGITAL REF. 1 ^{2,§)}	0
206	DIGITAL REF. 2 ^{2,§)}	0
207	DIGITAL REF. 3 ^{2,§)}	0
208	DIGITAL REF. 4 ^{2,§)}	0
209	CURRENT LIMIT ^{2,§)}	Depending on unit
210	LOW FREQ WARN ^{2,§)}	0 Hz
211	HI FREQ WARN ^{2,§)}	120 Hz (from 200)
213	HI CURR WARN ^{2,§)}	I _{VLT,MAX} (from 209)
215	RAMP UP TIME 1 ^{2,§)}	5 s
216	RAMP DOWN TIME 1 ^{2,§)}	5 s
218	ALT: DOWN RAMP ^{1,2,§)}	1 s
224	CARRIER FREQ. ^{2,§)}	4.5 Khz
230	SPEED UP/DOWN ^{§)}	DISABLE

■ Functions and timers

300	BRAKE OPTION ^{§)}	NOT APPLIED
306	DC-BRAKE TIME ^{2,§)}	0 s
307	DC-BRK FREQ ^{2,§)}	1 Hz
308	DC-BRK VOLTAGE ^{2,§)}	10 V
309	RESET MODE ^{§)}	MANUAL
310	TRIP DLY@C.LIM ^{§)}	INFINITE
315	MOTOR THERMAL ^{2,§)}	PROTECT-OFF

■ Inputs and outputs

402	INPUT 18 ^{§)}	START
403	INPUT 19 ^{§)}	REVERSING
404	INPUT 27 ^{§)}	MTR.COAST not
405	INPUT 29 ^{§)}	JOG
408	LOG OUTPUT 46 ^{2,§)}	UNIT READY
409	RELAY OUT 01 ^{2,§)}	UNIT READY
411	ANALOG REF TYPE ^{2,§)}	LINEAR
412	INPUT #53 ^{2,§)}	0 - 10 VDC
413	INPUT #60 ^{2,§)}	0-20 mA

■ Serial data interface

500	ADDRESS	01
501	BAUD RATE	1200 K
502	DATA READ-OUT ^{§)}	REFERENCE%
503	COASTING ^{§)}	LOGICAL OR
504	Q-STOP ^{§)}	LOGICAL OR
505	DC-BRAKE ^{§)}	LOGICAL OR
506	START ^{§)}	LOGICAL OR
507	DIRECTION ^{§)}	DIGITAL
508	RESET ^{§)}	LOGICAL OR
509	SETUP SELECT ^{§)}	LOGICAL OR
510	SPEED SELECT ^{§)}	LOGICAL OR
511	BUS JOG 1 ^{§)}	10 Hz
514	BUS BIT 4 ^{§)}	QUICK STOP
516	BUS REFERENCE ^{§)}	0
517	STORE DATA ^{§)}	OFF

■ Service and display

606	TOTAL OP HRS.
607	RUNNING HRS.
608	NO. POWERUPS
609	NO. OVERTEMPS
610	NO. OVERVOLTS

²⁾ Can be changed in both setups

^{§)} Can be changed i Start mode (running motor)

Factory settings and service

VLT serie 2000	1- and 3-phased, 208-240 V					3-phased, 208-240 V				
	Factory setting					User setting				
Parameter	VLT 2010	VLT 2015	VLT 2020	VLT 2030	VLT 2040	VLT 2050	VLT 2060 *			
103 Motor output (1)/(2)/(3), kW	0,25 0,37 0,55	0,37 0,55 0,75	0,55 0,75 1,1	1,1 1,5 2,2	1,5 2,2 3,0	3,0 4,0 5,5				
104 Motor voltage, V	220 220 220	220 220 220	220 220 220	220 220 220	220 220 220	220 220 220				
107 Motor current, A	1,5 2,0 2,8	2,0 2,8 3,5	2,8 3,5 4,9	4,9 6,4 9,0	6,4 9,0 12,0	12,0 15,8 21,1				
108 Motor excitation current, A	1,2 1,6 1,7	1,6 1,7 2,0	1,7 2,0 2,7	2,7 3,5 4,6	3,5 4,6 5,9	5,9 6,2 8,0				
109 Start voltage, V	32,0 30,5 25,9	30,5 25,9 24,3	25,9 24,3 23,8	23,8 22,9 22,3	22,9 22,3 21,0	21,0 20,6 20,4				
110 Start compensation	15,0 10,8, 8,8	10,8 8,8 6,7	8,8 6,7 3,5	6,7 3,5 2,0	3,5 2,0 0,77	2,0 0,77 0				
111 U/f ratio	3,6 3,7 3,9	3,7 3,9 4,0	3,9 4,0 4,0	4,0 4,0 4,1	4,0 4,1 4,1	4,1 4,1 4,1				
112 Slip compensation /%	4,26 3,99 2,55	3,99 2,55 2,43	2,55 2,43 2,01	2,01 1,87 1,63	1,87 1,63 1,40	1,40 1,30 1,04				
209 Current limit	3,5 3,5 3,5	4,9 4,9 4,9	6,3 6,3 6,3	10,5 10,5 10,5	17,0 17,0 17,0	26,7 26,7 26,7				
215 Ramp-up time	5 5 5	5 5 5	5 5 5	5 5 5	5 5 5	5 5 5				
216 Ramp-down time	5 5 5	5 5 5	5 5 5	5 5 5	5 5 5	5 5 5				
218 Quick Stop ramp	1 1 1	1 1 1	1 1 1	1 1 1	1 1 1	1 1 1				

VLT 2000	3-phased, 380-460 V					User setting				
	Factory setting					User setting				
Parameter	VLT 2020	VLT 2025	VLT 2030	VLT 2040	VLT 2050	VLT 2060 *				
103 Motor output (1)/(2)/(3), kW	0,55 0,75 1,1	0,75 1,1 1,5	1,1 1,5 2,2	1,5 2,2 3,0	2,2 3,0 4,0	3,0 4,0 5,5				
104 Motor voltage, V	400 400 400	400 400 400	400 400 400	400 400 400	400 400 400	400 400 400				
107 Motor current, A	1,7 2,0 2,8	2,0 2,8 3,7	2,8 3,7 5,3	3,7 5,3 6,9	5,3 6,9 9,1	6,9 9,1 12,2				
108 Motor excitation current, A	0,8 1,1 1,6	1,1 1,6 2,0	1,6 2,0 2,4	2,0 2,4 3,4	2,4 3,4 3,6	3,4 3,6 4,6				
109 Start voltage, V	42,8 40,0 39,1	40,0 39,1 39,1	39,1 39,1 36,8	39,1 36,8 36,3	36,8 36,3 35,6	36,3 35,6 35,4				
110 Start compensation	15,0 10,8, 8,8	10,8 8,8 6,7	8,8 6,7 3,5	6,7 3,5 2,0	3,5 2,0 0,77	2,0 0,77 0				
111 U/f ratio	6,8 6,8 6,8	6,8 6,8 6,9	6,8 6,9 7,0	6,9 7,0 7,1	7,0 7,1 7,1	7,1 7,1 7,1				
112 Slip compensation /%	2,55 2,43 1,80	2,43 1,80 1,90	1,80 1,90 1,60	1,90 1,60 1,40	1,60 1,40 1,30	1,40 1,30 1,04				
209 Current limit	3,8 3,8 3,8	4,5 4,5 4,5	6,4 6,4 6,4	9,0 9,0 9,0	12,2 12,2 12,2	15,5 15,5 15,5				
215 Ramp-up time	5 5 5	5 5 5	5 5 5	5 5 5	5 5 5	5 5 5				
216 Ramp-down time	5 5 5	5 5 5	5 5 5	5 5 5	5 5 5	5 5 5				
218 Quick Stop ramp	1 1 1	1 1 1	1 1 1	1 1 1	1 1 1	1 1 1				

*) VLT 2060: Max: 415V

A		H	
Acoustic noise	92	High voltage test	44
Advanced motor protection	25	How to connect control signals	43
Air humidity	93	How to find the right code number	32
Altering a data value (digits)	47	How to lock programming function	48
Altering a data value (text)	47	How to program	15
 B		 I	
Back to Display group	48	Improved process	22
Back to the factory setting	48	Improved quality	22
Before you start	6	 J	
Brake function	33	Jording	88
Built-in compact RFI filter	12, 33	 K	
 C		 L	
Cables	17	LC and RFI filter (module)	34
Commissioning and testing	18	Less maintenance	22
Constant torque CT	24	Light diodes	48
Contents	1	Long motor cables	25
Control accuracy	25	 M	
control cables	17	Machine directive	86
Cut-in current	96	Mechanical installation	6
 D		Motor coils (module)	34
Danfoss VVC principle	23	Motor noise	92
Derating for air pressure	95	 O	
Derating for high ambient temperature	94	Operating without control panel	48
Derating for running at low speed	95	Operating your VLT	46
Description of parameters	61	 P	
Dimensions	35	Parameter settings	102
Display	46	Prefuses	44
du/dt measurements	94	Product range	32
 E		Programmable control inputs and signal outputs in	25
Efficiency	93	Protection against mains disturbance	25
Electrical installation	6	Push buttons	46
EMC directive	86	 Q	
EMC test results	90	Quick Setup	14
Emission	90	 G	
Extreme running conditions	92	Galvanic isolation	25
 F		Grounding	17
Factory-programmed optimization	24	Groups (modes)	48

R

RFI and motor filter (module) 34

S

Saved energy 22

Side by side mounting 44

Sizing 30

Slip compensation 24

Start compensation 24

Start voltage 24

Survey of connection terminals 42

Survey of terminals 16

T

Technical data 38

U

U/f ratio 24

V

VLT control commands 57

VLT status 56

VVC principle 23

