

OF5027

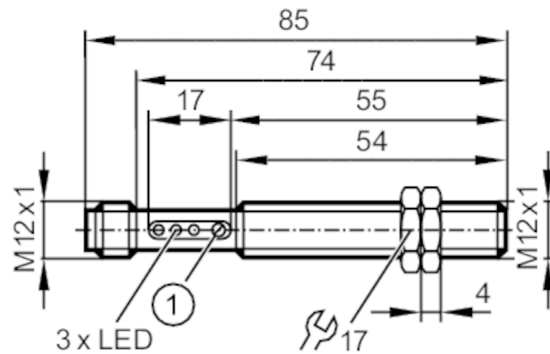

Diffuse reflection sensor

OFB-FPKG/US-100



1 potentiometer



Product characteristics

Type of light	Infrared light
Housing	Threaded type
Dimensions [mm]	M12 x 1 / L = 74

Application

System	Function check output
Function principle	Diffuse reflection sensor

Electrical data

Operating voltage [V]	10...36 DC
Current consumption [mA]	< 35
Protection class	II
Reverse polarity protection	yes
Type of light	Infrared light
Wave length [nm]	880

Outputs

Electrical design	PNP
Output function	light-on/dark-on mode; (programmable)
Max. voltage drop switching output DC [V]	2.5
Function check output	yes
Max. voltage drop of function check output [V]	3.5
Max. current load for function check output [mA]	10
Permanent current rating of switching output DC [mA]	200
Switching frequency DC [Hz]	320
Short-circuit protection	yes
Type of short-circuit protection	yes (non-latching)
Overload protection	yes

OF5027



Diffuse reflection sensor

OFB-FPKG/US-100

Monitoring range		
Range [mm]	1...400; (white paper 200 x 200 mm)	
Range adjustable	yes	
Max. light spot diameter [mm]	185	
Light spot dimensions refer to	at maximum range	
Operating conditions		
Ambient temperature [°C]	-25...60	
Protection	IP 65	
Tests / approvals		
EMC	EN 60947-5-2	
MTTF [years]	607	
Mechanical data		
Weight [g]	46.6	
Housing	Threaded type	
Dimensions [mm]	M12 x 1 / L = 74	
Thread designation	M12 x 1	
Material	brass white bronze coated	
Lens material	PMMA	
Displays / operating elements		
Display	Switching status	1 x LED, yellow
	Power	1 x LED, green
	Function	1 x LED, red
Accessories		
Accessories (supplied)	lock nuts: 2 x screwdrivers	
Remarks		
Pack quantity	1 pcs.	
Electrical connection		
Connector: 1 x M12		
		



Diffuse reflection sensor

OFB-FPKG/US-100

Connection

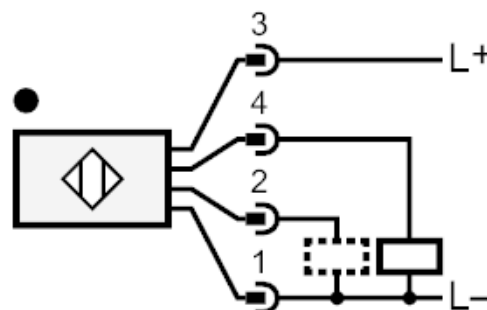
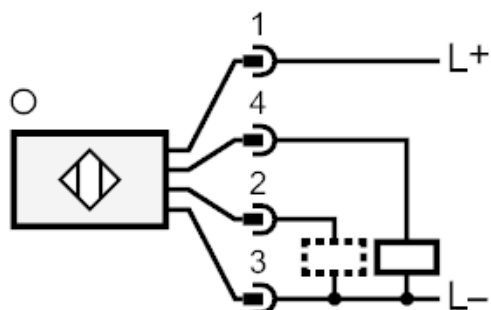

2 Function check output

Diagrams and graphs

excess gain graph

