

Control Switches

CG, CH and CHR type up to 25 A

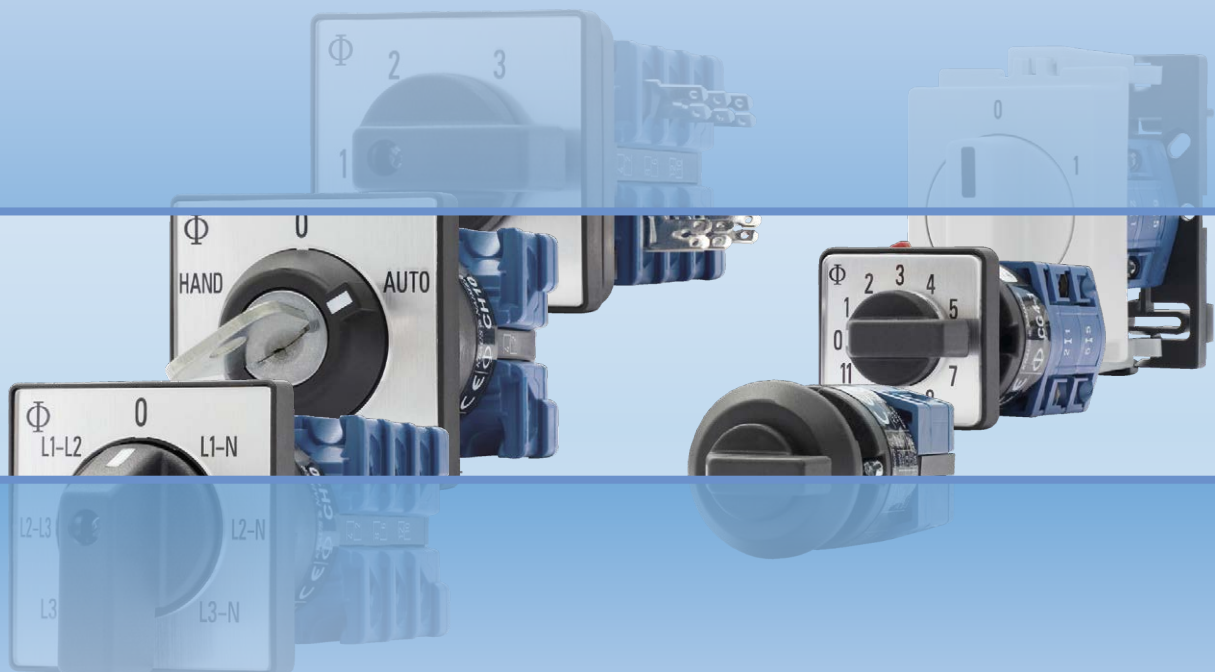

Kraus & Naimer

The development of the Blue Line rotary switch and motor starter product ranges is based on more than hundred years experience by Kraus & Naimer in the design and manufacture of electrical switchgear. Kraus & Naimer pioneered the introduction of the cam operated rotary switch and continues to be recognized as the world leader in that product field.

BLUE LINE

Blue Line products are protected by numerous patents through-out the industrial world. They are built to national and international standards and designed to withstand adverse temperatures and climates.

Blue Line products are accepted and universally recognized for their quality and workmanship. They are supported by a worldwide sales and service organization.

The Kraus & Naimer Registered Trademark



WORLDWIDE SYMBOL
FOR QUALITY SWITCHGEAR

Disconnectors and Main Switches acc. to IEC 60947-3 see Catalog 500

| Contents | Page |
|---------------------------------------|-------------|
| Construction Data | 4 |
| Dimensions and Nominal Ratings | 5 |
| How to order | 6, 7 |
| Switch Function and Configuration | |
| ON/OFF Switches | 9 |
| Double-throw Switches | 10-12 |
| General Application Switches | 12 |
| Coding Switches | 13 |
| Multi-step Switches | 14-16 |
| Voltmeter Switches | 17-19 |
| Ammeter Switches | 19-21 |
| Volt-ammeter Switches | 21 |
| Control Switches | 21, 22 |
| Motor Switches | 23-25 |
| Types of Mounting | |
| Panel Mounting | 26-29 |
| Base Mounting | 30, 31 |
| Face Plates | 32, 33 |
| Handles | 34 |
| International Standards and Approvals | 35 |
| Technical Data | 36-39 |
| Dimensions | |
| Panel Mounting | 40-43 |
| Base Mounting | 44, 45 |
| Overall Switch Lengths | 45, 46 |
| Blue Line Switchgear: Summary | 48 |

Construction Data

Cam switches of the CG, CH and CHR-series are designed for universal application and may ideally be used for control switches, instrumentation switches and motor control switches. Different contact designs, contact materials and terminals allow the use as well as in electronic circuitry and in aggressive environments in accordance with IEC 60947-3, EN 60947-3, VDE 0660 part 107, UL and cUL (cUR).

The stage is the basis for all switches and can be supplied with a maximum of 2 contacts. All switches of this series are supplied with open terminals which are accessible while the switch is installed. The terminals are protected against accidental finger contact according to EN 50274, VDE 0660 part 514 and DGUV V3. Captive plus-minus terminal screws and integrated screwdriver guides facilitate wiring. Due to the particular arrangement of the terminals of the CG switches, it is

possible to install the switches closely, side by side, or to mount them directly at the cable trays. The contact terminal numbers are easy to read, even if the switch is installed.

The captive plus-minus screws of the CH and CHR-series are located about 90° apart from the terminal direction. This allows for connecting wires without any interference with the terminal screws.

For connection with ring type terminals the CHR-series were designed. The switches are supplied with large open terminals. This allows for connection without removing the screws.

3 different Contact Systems are available

CG6 to
CHR16B

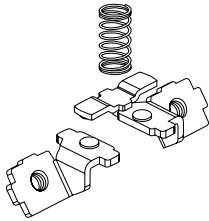

A rigid, double-break bridge with silver alloy contacts provides high making and breaking capabilities for regular control applications.

CG4 and
CG4-1

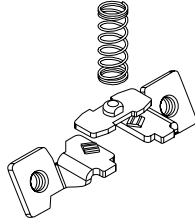

High contact reliability by multiple cross-point contacts.

CGD4-1

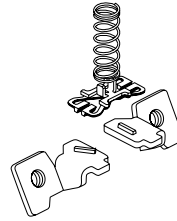

High contact reliability by H-bridge design with "cross-wire" contacts. The contact system with gold-plated contacts (CH12/CHR12 with silver contact) allows for low voltages, electronic compatible.

CH11/CHR11
CH12/CHR12

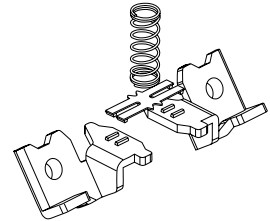

| Type | Size | Possible Switching Angles | Max. No. of Stages |
|--------------|------|---------------------------|--------------------|
| CG4-CGD4-1 | S00 | 30°, 45°, 60°, 90° | 8 |
| CG6-CHR6* | S00 | 30°, 45°, 60°, 90° | 5/4* |
| CG8-CHR16 | S0 | 30°, 45°, 60°, 90° | 12 |
| CG8B | S1 | 30°, 45°, 60°, 90° | 12 |
| CH10B-CHR16B | S1 | 30°, 45°, 60°, 90° | 12 |
| CG8S | S0 | 60° | on request |

CG-series

CH-series

CHR-series

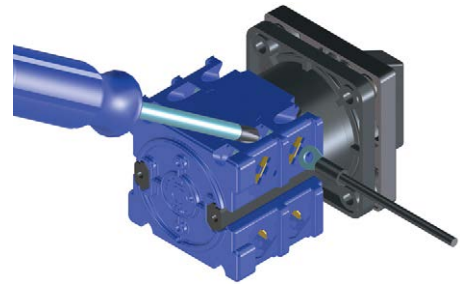
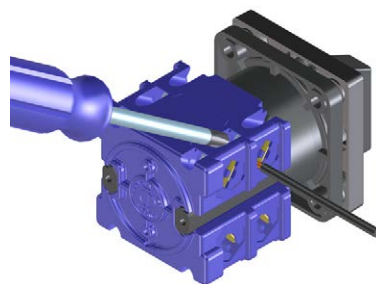

Above illustrates the standard terminal positions.

Nominal Ratings

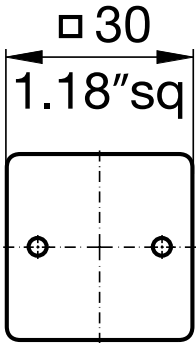
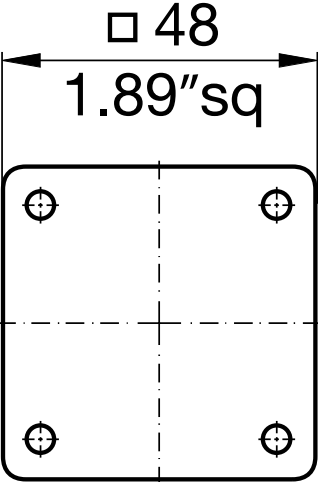
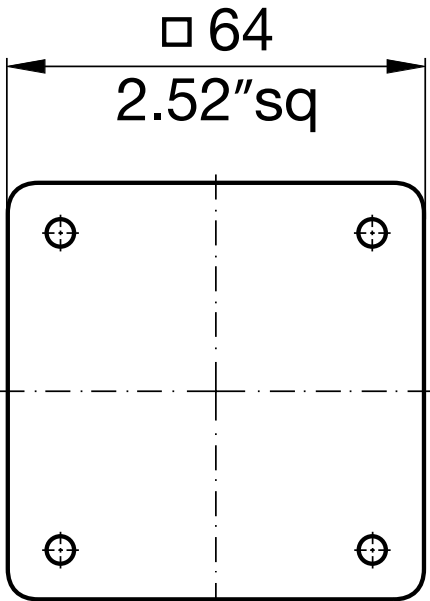
| Switch Size | Type | According to IEC 60947-3, EN 60947-3, VDE 0660 part 107 | | | |
|--|---------------|---|---------------------------------|--|-----|
| | | Insulation Voltage ¹ U_i | Thermal Current I_u/I_{th} | Motor Rating 3 x 380 V-440 V AC-23A AC-3 | |
| | | V | A | kW | kW |
| S00  | CG4 | 440 | 10 | 3 | 2,2 |
| | CG4-1 | 440 | 10 | 3 | 2,2 |
| | CGD4-1 | 440 | 5 | - | - |
| | CG6 | 690 | 20 | 7,5 | 5,5 |
| | CH6 | 690 | 20 | 7,5 | 5,5 |
| | CHR6 | 690 | 20 | 7,5 | 5,5 |
| S0  | CG8 | 690 | 20 | 7,5 | 5,5 |
| | CH10 | 690 | 20 | 7,5 | 5,5 |
| | CH11 | 600 | 6 | - | - |
| | CH12 | 600 | 6 | - | - |
| | CH16 | 690 | 25 | 11 | 7,5 |
| | CHR10 | 690 | 20 | 7,5 | 5,5 |
| | CHR11 | 600 | 6 | - | - |
| | CHR12 | 600 | 6 | - | - |
| | CHR16 | 690 | 25 | 11 | 7,5 |
| S1  | CH10B | 690 | 20 | 7,5 | 5,5 |
| | CH16B | 690 | 25 | 11 | 7,5 |
| | CHR10B | 690 | 20 | 7,5 | 5,5 |
| | CHR16B | 690 | 25 | 11 | 7,5 |

[< back to table of contents >](#)

For further technical details, refer to pages 36-38.

¹Valid for lines with grounded common neutral termination, overvoltage category III, pollution degree 3. Values for other supply systems on request.

How to order

Disconnectors and Main Switches according to IEC 60947-3 see Catalog 500

Three types of data (shown below) are required for ordering Blue Line cam-operated switches. Code numbers for ordering are shown in this catalog.

1. Type of Switch

The type of switch required may be easily selected by referring to the table on page 5 which shows the thermal current, power rating and dimensions of each switch. For further technical details, refer to pages 36-38. Variations of contacts and terminals are shown below.

2. Switch Function

The code numbers for standard switches shown on pages 8-25 indicate the switch function, escutcheon plate, handle and any optional extras.

Additional coding to modify type and color of handle and escutcheon plate is explained below.

3. Type of Mounting

Types of mounting are shown on pages 26-31. Catalog 101 describes enclosures and optional extras.

Specify the mounting code to indicate required mounting.

CH10

A202

VE

Type of Switch

Extending the switch type coding the following combinations will define:

| Amendment | Definition | For switch types |
|-----------------|--|--|
| -1 | with gold contacts ¹ | CG4-1, CGD4-1, CH10-1, CH10B-1, CH16B-1, CHR6-1, CHR10-1 |
| -4 ² | with quick connects (nickel-plated) | CH10-4, CH10B-4, CH16-4, CH16B-4 |
| -6 ² | with angled quick connects (nickel-plated) | CH10-6, CH10S-6, CH16-6 |
| B | S0 switches with latching mechanism size S1 | CH6-6, CH10-6, CH10S-6, CH16-6 CG8B, CH10B, CH11B, CH12B, CH16B, CH16B, CHR10B, CHR16B for four hole panel mounting CH10L, CHR10L, CHR16L |
| L | with lockout-relay w/o manual release | CHR10M |
| M | with lockout-relay with manual release | CG8X |
| X | with power failure release | CG8R, CH10R, CH11R, CHR10R, CHR11R |
| R | with spring return latching mechanism | CG8S, CH10S, CH16S, CHR10S, CHR16S |
| S | with snap action | with 60° or 90° switching |
| Y | with power failure release and trip-free release | CG8Y |

Example: Coding for switch type **CH10** with latching mechanism size S1 is **CH10B**.

¹Technical data on request. ²Connection Diagrams on request.

Handles, Escutcheon Plates and Optional Extras

The handles for standard switches shown on pages 8-25 are suitable for mounting units with four hole mounting. Alternative types of handles available are illustrated on pages 26-31.

When a handle, escutcheon plate or optional extra is required but not covered by the dash number, the code number for the selected component should be entered separately. A comprehensive range of available standard escutcheon plates is illustrated on pages 32-34. Non-standard or special escutcheon plate engravings are available at extra cost. The large number of optional extras and enclosures is covered in Catalog 101.

Switch Size

CG, CH and CHR switches are available in sizes S00, S0 and S1. These size codes indicate the dimension of the mounting, the escutcheon plate and the handle, as well as the size of optional devices and enclosures. Page 5 lists these sizes and the various switch types they include.

Notes:

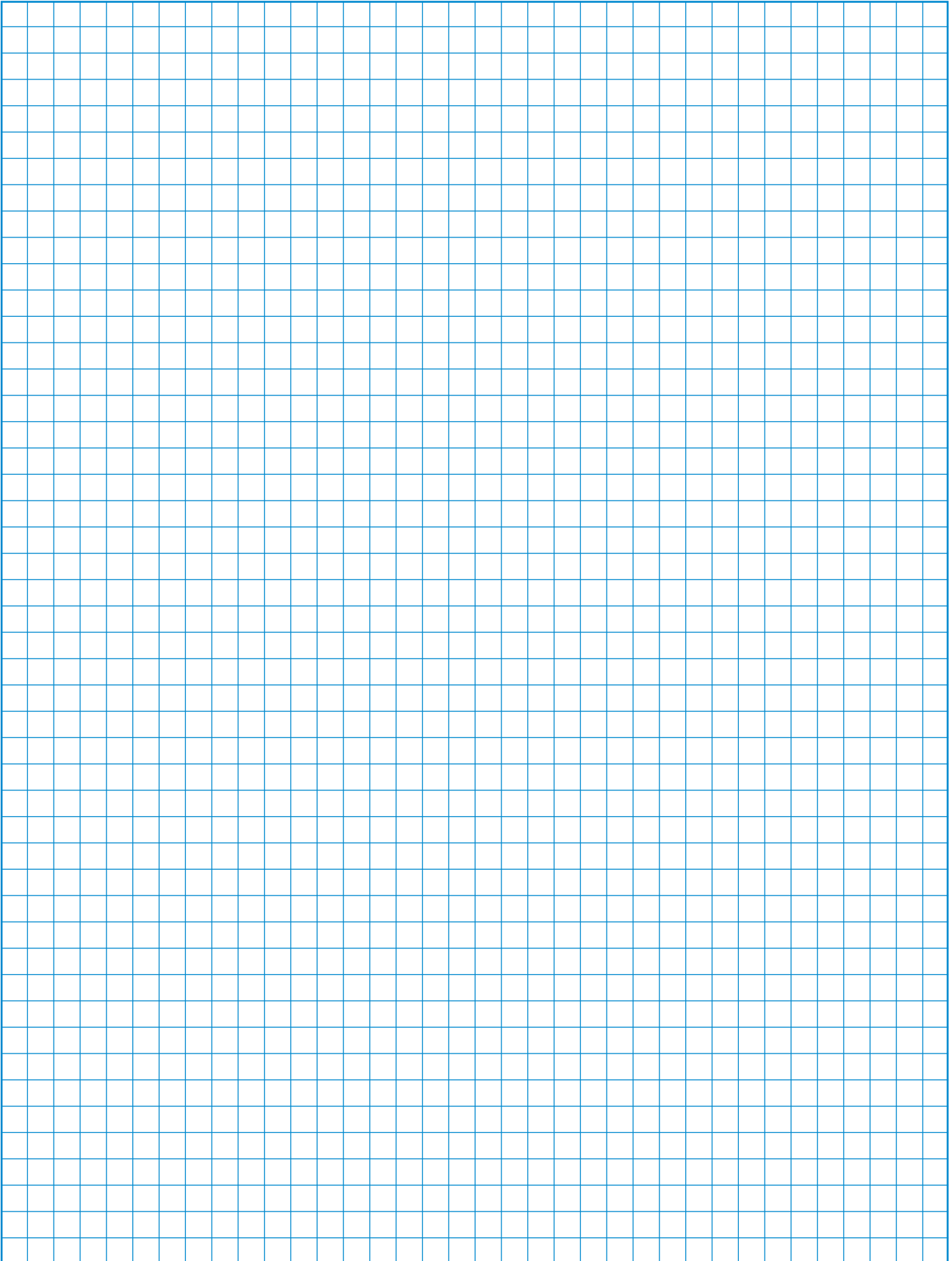

























































[< back to table of contents >](#)

| Function | Escutch. Plate | Type/Handle | | | | Code | Stages | Connection Diagram |
|----------|----------------|----------------|--------------|----------------|------------------|------|--------|--------------------|
| | | CG4- CGD4-1 | CG6- CHR6 | CH10- CHR16 | CH10B- CHR16B | | | |







































ON/OFF Switches with 60° Switching

[Dimensions p. 46](#)



































| | | | | | | | | | | | | | | | | | | | | |
|--|---|---|---|---|---|--------|---|---|---|---|---|---|----|----|----|----|----|----|----|---|
| 1 pole |  F070 |  |  |  |  | A200 | 1 | 1 | 1 | 3 | 5 | 7 | 9 | 11 | 13 | 15 | 17 | 19 | 21 | |
| 2 pole | |  |  |  |  | A201 | 1 | 2 | 2 | 4 | 6 | 8 | 10 | 12 | 14 | 16 | 18 | 20 | 22 | |
| 3 pole | |  |  |  |  | A202 | 2 | 3 | 2 | 2 | 2 | 2 | 2 | 2 | 2 | 2 | 2 | 2 | 2 | 2 |
| 4 pole | |  |  |  |  | A203 | 2 | 3 | 2 | 2 | 2 | 2 | 2 | 2 | 2 | 2 | 2 | 2 | 2 | 2 |
| 4 pole 1 pole preclose 6° ¹ | |  |  |  |  | WAA653 | 2 | 3 | 2 | 2 | 2 | 2 | 2 | 2 | 2 | 2 | 2 | 2 | 2 | 2 |
| 5 pole | |  |  |  |  | WAA341 | 2 | 3 | 2 | 2 | 2 | 2 | 2 | 2 | 2 | 2 | 2 | 2 | 2 | 2 |
| 6 pole | |  |  |  |  | A342 | 3 | 3 | 2 | 2 | 2 | 2 | 2 | 2 | 2 | 2 | 2 | 2 | 2 | 2 |
| 7 pole | |  |  |  |  | A343 | 3 | 3 | 2 | 2 | 2 | 2 | 2 | 2 | 2 | 2 | 2 | 2 | 2 | 2 |
| 8 pole | |  |  |  |  | A344 | 4 | 4 | 2 | 2 | 2 | 2 | 2 | 2 | 2 | 2 | 2 | 2 | 2 | 2 |
| 8 pole 2 pole preclose 6° ¹ | |  |  |  |  | WAA654 | 4 | 4 | 2 | 2 | 2 | 2 | 2 | 2 | 2 | 2 | 2 | 2 | 2 | 2 |
| 9 pole | |  |  |  |  | WAA345 | 5 | 5 | 2 | 2 | 2 | 2 | 2 | 2 | 2 | 2 | 2 | 2 | 2 | 2 |
| 10 pole | |  |  |  |  | A346 | 5 | 6 | 2 | 2 | 2 | 2 | 2 | 2 | 2 | 2 | 2 | 2 | 2 | 2 |
| 11 pole |  |  |  |  | WAA347 | 6 | 6 | 2 | 2 | 2 | 2 | 2 | 2 | 2 | 2 | 2 | 2 | 2 | 2 | |
| 12 pole |  |  |  |  | A348 | 6 | 6 | 2 | 2 | 2 | 2 | 2 | 2 | 2 | 2 | 2 | 2 | 2 | 2 | |

ON/OFF Switches with 90° Switching

[< back to table of contents >](#)

| | | | | | | | | | | | | | | | | | | |
|---|---|---|---|---|---|--------|---|---|---|---|---|---|----|----------------------------|--|--|--|--|
| 1 pole contacts |  F056 |  |  |  |  | A290 | 1 | 1 | 1 | 3 | 5 | 7 | 9 | | | | | |
| 2 pole preclose 30° | |  |  |  |  | A291 | 1 | 2 | 2 | 4 | 6 | 8 | 10 | 1, 2, 3, 4, 5 and 6 pole | | | | |
| 3 pole | |  |  |  |  | A292 | 2 | 2 | 2 | 2 | 2 | 2 | 2 | | | | | |
| 4 pole | |  |  |  |  | A324 | 2 | 2 | 2 | 2 | 2 | 2 | 2 | | | | | |
| 4 pole 1 pole preclose 60° ¹ | |  |  |  |  | A293 | 2 | 3 | 2 | 2 | 2 | 2 | 2 | 4 pole 1 pole preclose 60° | | | | |
| 4 pole 3 pole preclose 30° | |  |  |  |  | WAA327 | 2 | 3 | 2 | 2 | 2 | 2 | 2 | 4 pole 1 pole preclose 60° | | | | |
| 5 pole contacts |  F062 |  |  |  |  | WAA325 | 3 | 3 | 2 | 2 | 2 | 2 | | | | | | |
| 6 pole preclose 30° | |  |  |  |  | A326 | 3 | 3 | 2 | 2 | 2 | 2 | | | | | | |
| 3 pole 360° rotation | |  |  |  |  | WAA208 | 2 | 2 | 2 | 2 | 2 | 2 | | | | | | |
| 3 pole for foot operation |  | | | | | WAA386 | 2 | 2 | 2 | 2 | 2 | 2 | | | | | | |







































































ON/OFF Switches with 30° Switching

| | | | | | | | | | | | | | | | | | |
|---------------------------|---|---|---|---|---|--------|---|---|---|---|---|---|----------|--|--|--|--|
| 1 pole |  F169 |  |  |  |  | WAA100 | 1 | 1 | 1 | 3 | 5 | 7 | | | | | |
| 2 pole | |  |  |  |  | WAA101 | 1 | 2 | 2 | 4 | 6 | 8 | 1-4 pole | | | | |
| 3 pole | |  |  |  |  | WAA102 | 2 | 2 | 2 | 2 | 2 | 2 | | | | | |
| 4 pole | |  |  |  |  | WAA103 | 2 | 2 | 2 | 2 | 2 | 2 | | | | | |
| 1 pole with spring return |  F153 |  |  |  |  | A204 | 1 | 1 | 1 | 3 | 5 | 7 | | | | | |
| 2 pole with spring return | |  |  |  |  | A205 | 1 | 2 | 2 | 4 | 6 | 8 | 1-4 pole | | | | |
| 3 pole with spring return | |  |  |  |  | WAA206 | 2 | 2 | 2 | 2 | 2 | 2 | | | | | |
| 4 pole with spring return | |  |  |  |  | WAA207 | 2 | 2 | 2 | 2 | 2 | 2 | | | | | |

| Function | Escutch. Plate | Type/Handle | | | | Code | Stages | Connection Diagram ² |
|----------|----------------|----------------|--------------|----------------|------------------|------|--------|---------------------------------|
| | | CG4- CGD4-1 | CG6- CHR6 | CH10- CHR16 | CH10B- CHR16B | | | |

































Double-throw Switches without „OFF“ 60° Switching

[Dimensions p. 46](#)





































| | | | | | | | | | |
|--|---|---|---|---|---|--------|---|---|--------------------|
| 1 pole |  <p>F072</p> |  |  |  |  | A220 | 1 |  | 1 3 5 7 9 11 13 15 |
| 2 pole | |  |  |  |  | A221 | 2 |  | 1 3 5 7 9 11 13 15 |
| 3 pole | |  |  |  |  | A222 | 3 |  | 1 3 5 7 9 11 13 15 |
| 4 pole | |  |  |  |  | A223 | 4 |  | 1 3 5 7 9 11 13 15 |
| 4 pole 1 pole preclose 6° ¹ | |  |  |  |  | WAA673 | 4 |  | 1 3 5 7 9 11 13 15 |
| 5 pole | |  |  |  |  | A369 | 5 |  | 1 3 5 7 9 11 13 15 |
| 6 pole | |  |  |  |  | A370 | 6 |  | 1 3 5 7 9 11 13 15 |
| 7 pole | |  |  |  |  | A371 | 7 |  | 1 3 5 7 9 11 13 15 |
| 8 pole | |  |  |  |  | A372 | 8 |  | 1 3 5 7 9 11 13 15 |
| 8 pole 2 pole preclose 6° ¹ | |  |  |  |  | WAA972 | 8 |  | 1 3 5 7 9 11 13 15 |
| 9 pole | |  |  |  |  | WAA373 | 9 |  | 1 3 5 7 9 11 13 15 |
| 10 pole | |  |  |  |  | WAA374 | 10 |  | 1 3 5 7 9 11 13 15 |
| 11 pole |  |  |  |  | WAA375 | 11 |  | 1 3 5 7 9 11 13 15 | |
| 12 pole |  |  |  |  | WAA376 | 12 |  | 1 3 5 7 9 11 13 15 | |

[< back to table of contents >](#)

Double-throw Switches without „OFF“ with electrically isolated contacts

| | | | | | | | | | |
|--|---|---|---|---|---|--------|---|---|--------------------|
| 1 pole |  <p>F072</p> |  |  |  |  | A720 | 1 |  | 1 3 5 7 9 11 13 15 |
| 2 pole | |  |  |  |  | A721 | 2 |  | 1 3 5 7 9 11 13 15 |
| 3 pole | |  |  |  |  | A722 | 3 |  | 1 3 5 7 9 11 13 15 |
| 4 pole | |  |  |  |  | A723 | 4 |  | 1 3 5 7 9 11 13 15 |
| 4 pole 1 pole preclose 6° ¹ | |  |  |  |  | WAA973 | 4 |  | 1 3 5 7 9 11 13 15 |
| 1 pole with spring return |  <p>F026</p> |  |  |  |  | A795 | 1 |  | 1 3 5 7 9 11 13 15 |

Double-throw Switches without „OFF“ 30° Switching

| | | | | | | | | | |
|---------------------------|---|---|---|---|---|--------|---|---|--------------------|
| 1 pole |  <p>F026</p> |  |  |  |  | WAA120 | 1 |  | 1 3 5 7 9 11 13 15 |
| 2 pole | |  |  |  |  | WAA121 | 2 |  | 1 3 5 7 9 11 13 15 |
| 3 pole | |  |  |  |  | WAA122 | 3 |  | 1 3 5 7 9 11 13 15 |
| 4 pole | |  |  |  |  | WAA123 | 4 |  | 1 3 5 7 9 11 13 15 |
| 1 pole with spring return |  <p>F026</p> |  |  |  |  | A295 | 1 |  | 1 3 5 7 9 11 13 15 |
| 2 pole with spring return | |  |  |  |  | A296 | 2 |  | 1 3 5 7 9 11 13 15 |
| 3 pole with spring return | |  |  |  |  | WAA297 | 3 |  | 1 3 5 7 9 11 13 15 |

¹For use in a three phase four-wire system with switched neutral. ²Connection diagrams for CHR switches on request.

| Function | Escutch. Plate | Type/Handle | | | | Code | Stages | Connection Diagram ² |
|----------|----------------|----------------|--------------|----------------|------------------|------|--------|---------------------------------|
| | | CG4- CGD4-1 | CG6- CHR6 | CH10- CHR16 | CH10B- CHR16B | | | |

Double-throw Switches with Center „OFF“ 60° Switching

[Dimensions p. 46](#)

| | | | | | | | | |
|--|-------------|--|--|--|--------|--------|----------------------------------|----------------------------------|
| 1 pole | <p>F071</p> | | | | | A210 | 1 | <p>1-4 pole</p> |
| 2 pole | | | | | | A211 | 2 | |
| 3 pole | | | | | | A212 | 3 | |
| 4 pole | | | | | | A213 | 4 | |
| 4 pole 1 pole preclose 6° ¹ | | | | | | WAA913 | 4 | |
| 5 pole | | | | | | A361 | 5 | |
| 6 pole | | | | | | A362 | 6 | |
| 7 pole | | | | | | WAA363 | 7 | |
| 8 pole | | | | | WAA364 | 8 | <p>4 pole 1 pole preclose 6°</p> | |
| 8 pole 2 pole preclose 6° ¹ | | | | | WAA664 | 8 | | |
| | | | | | | | | <p>5 pole</p> |
| | | | | | | | | <p>6 and 7 pole</p> |
| | | | | | | | | <p>8 pole</p> |
| | | | | | | | | <p>8 pole 2 pole preclose 6°</p> |

[< back to table of contents >](#)

Double-throw Switches with Center „OFF“ 90° Switching

| | | | | | | | | |
|--|-------------|--|--|--|--|--------|---|-----------------|
| 1 pole | <p>F057</p> | | | | | A218 | 1 | <p>1-4 pole</p> |
| 2 pole | | | | | | A219 | 2 | |
| 3 pole | | | | | | WAA299 | 3 | |
| 4 pole 1 pole preclose 6° ¹ | | | | | | WAA294 | 4 | |

Double-throw Switches with Center „OFF“ and electrically isolated contacts











| | | | | | | | | |
|--|-------------|--|--|--|--|--------|---|----------------------------------|
| 1 pole | <p>F071</p> | | | | | A710 | 1 | <p>1-4 pole</p> |
| 2 pole | | | | | | A711 | 2 | |
| 3 pole | | | | | | A712 | 3 | |
| 4 pole 1 pole preclose 6° ¹ | | | | | | A713 | 4 | |
| 4 pole 1 pole preclose 6° ¹ | | | | | | WAA963 | 4 | <p>4 pole 1 pole preclose 6°</p> |
| 1 pole with spring return | <p>F025</p> | | | | | A714 | 1 | <p>1 and 2 pole</p> |
| 2 pole to center | | | | | | A715 | 2 | |

¹For use in a three phase four-wire system with switched neutral. ²Connection diagrams for CHR switches on request.

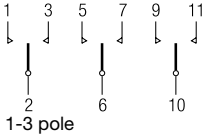





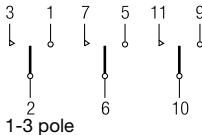







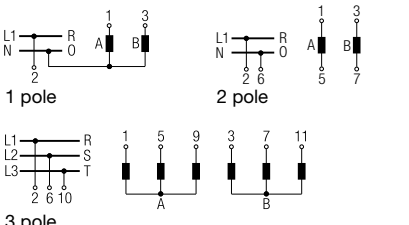





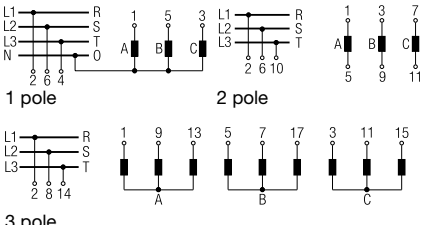

| Function | Escutch. Plate | Type/Handle | | | | Code | Stages | Connection Diagram ¹ |
|----------|----------------|----------------|--------------|----------------|------------------|------|--------|---------------------------------|
| | | CG4- CGD4-1 | CG6- CHR6 | CH10- CHR16 | CH10B- CHR16B | | | |

Double-throw Switches with Spring Return to Center

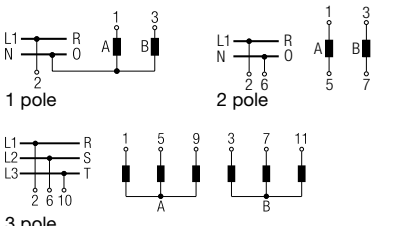
[Dimensions p. 46](#)

| | | | | | | | | |
|---|---|---|---|---|---|----------------------|-------------|---|
| 1 pole with spring return 2 pole to center 3 pole |  F025 |  |  |  |  | A214 A215 A216 | 1 2 3 |  |
| 1 pole with spring return 2 pole from left to center 3 pole |  F361 |  |  |  |  | A320 A321 A322 | 1 2 3 |  |

General Application Switches

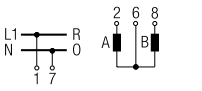
| | | | | | | | | |
|---|---|---|---|---|---|----------------------------|-------------|---|
| 1 pole 2 Gang 2 pole Switching sequence: 3 pole 0, A, A+B |  F075 |  |  |  |  | A310 A312 WAA314 | 1 2 3 |  |
| 1 pole 3 Gang 2 pole Switching sequence: 3 pole 0, A, A+B, A+B+C |  F001 |  |  |  |  | A311 WAA313 WAA315 | 2 3 5 |  |
| 1 pole 2 Gang 2 pole Series switching 3 pole Switching sequence: 0, A, B, A+B |  F001 |  |  |  |  | WAA330 WAA331 WAA332 | 1 2 3 |  |
| 2 pole 2 Gang Series-parallel Switching Switching sequence: 0, A+B series, A, A+B parallel |  F001 |  |  |  |  | WAA339 | 2 |  |

[< back to table of contents >](#)













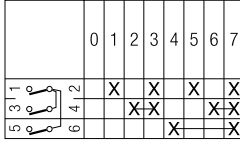



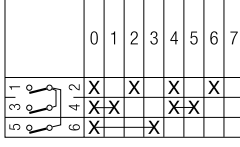



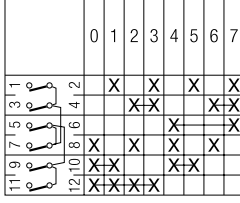



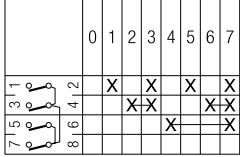



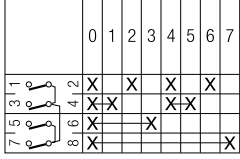

¹Connection diagrams for CHR switches on request.

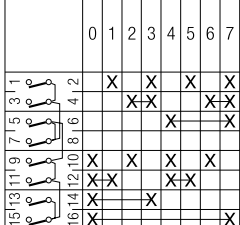
| Function | Escutch. Plate | Type/Handle | | | | Code | Stages | Connection Diagram |
|----------|-------------------|----------------|--------------|--------------|------------------|------|--------|--------------------|
| | | CG4- CGD4-1 | CG6- CHR6 | CH11 CH12 | CH10B- CHR16B | | | |

Coding Switches/Binary Code

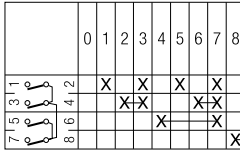
[Dimensions p. 46](#)



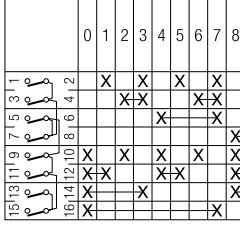







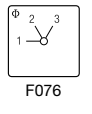



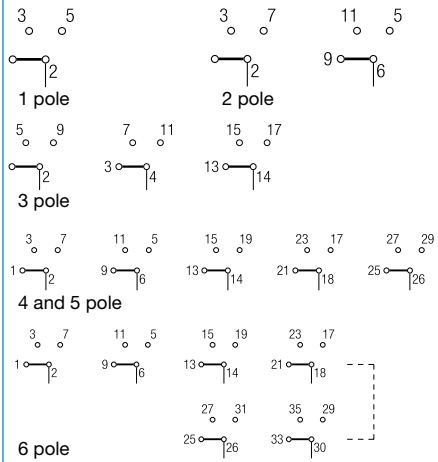
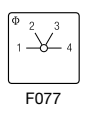



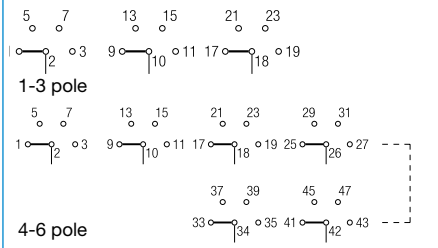
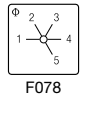



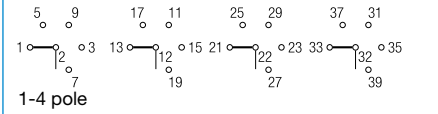
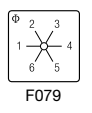



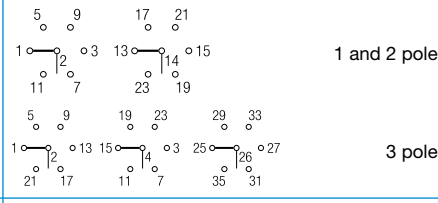
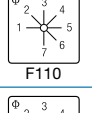



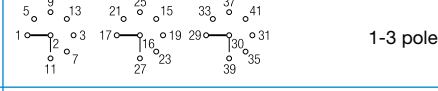
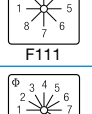



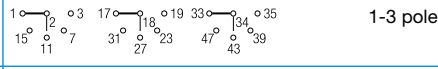
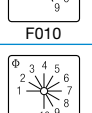





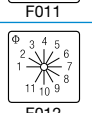







[< back to table of contents >](#)

| | | | | | | |
|--------------------------------------|---|---|---|--------|---|---|
| 0 - 7 360° rotation |  |  |  | A540 | 2 |  |
| 0 - 7 complement 360° rotation |  |  |  | WAA541 | 2 |  |
| 0 - 7 + complement 360° rotation |  |  |  | WAA542 | 3 |  |
| 0 - 9 |  |  |  | A550 | 2 |  |
| 0 - 9 complement |  |  |  | WAA551 | 2 |  |
| 0 - 9 + complement |  |  |  | WAA552 | 4 |  |
| 0 - 11 360° rotation |  |  |  | WAA543 | 2 |  |
| 0 - 11 + complement 360° rotation |  |  |  | WAA545 | 4 |  |

| Function | Escutch. Plate | Type/Handle | | | | Code | Stages | Connection Diagram ¹ |
|----------|----------------|----------------|--------------|----------------|------------------|------|--------|---------------------------------|
| | | CG4- CGD4-1 | CG6- CHR6 | CH10- CHR16 | CH10B- CHR16B | | | |

Multi-step Switches without „OFF“

Dimensions p. 46





















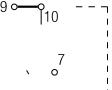
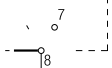











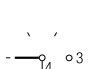

| | | | | | | | | |
|---|---|---|---|---|---|--|------------------------------|---|
| 1 pole 3 Step 2 pole 3 pole 4 pole 5 pole 6 pole |  |  |  |  |  | A230 A250 A270 A476 WAA484 WAA489 | 2 3 5 6 8 9 |  |
| 1 pole 4 Step 2 pole 3 pole 4 pole 5 pole 6 pole |  |  |  |  |  | A231 A251 A271 A477 WAA485 WAA490 | 2 4 6 8 10 12 |  |
| 1 pole 5 Step 2 pole 3 pole 4 pole |  |  |  |  |  | A232 A252 WAA272 WAA478 | 3 5 8 10 |  |
| 1 pole 6 Step 2 pole 3 pole |  |  |  |  |  | A233 WAA253 WAA273 | 3 6 9 |  |
| 1 pole 7 Step 2 pole 3 pole |  |  |  |  |  | WAA234 WAA254 WAA274 | 4 7 11 |  |
| 1 pole 8 Step 2 pole 3 pole |  |  |  |  |  | WAA235 WAA255 WAA275 | 4 8 12 |  |
| 1 pole 9 Step |  |  |  |  |  | WAA236 | 5 |  |
| 1 pole 10 Step |  |  |  |  |  | WAA237 | 5 |  |
| 1 pole 11 Step |  |  |  |  |  | WAA238 | 6 |  |
| 1 pole 12 Step 1 pole 360° rotation |  |  |  |  |  | WAA239 WAA639 | 6 6 |  |

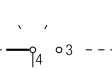
[< back to table of contents >](#)



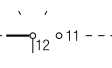















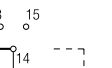



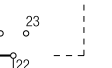



























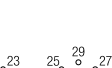

¹Connection diagrams for CHR switches on request.

| Function | Escutch. Plate | Type/Handle | | | | Code | Stages | Connection Diagram ¹ |
|----------|----------------|----------------|--------------|----------------|------------------|------|--------|---------------------------------|
| | | CG4- CGD4-1 | CG6- CHR6 | CH10- CHR16 | CH10B- CHR16B | | | |

Multi-step Switches without „OFF“ with electrically isolated contacts [Dimensions p. 46](#)

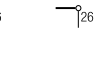
| | | | | | | | | |
|---------------|---|---|---|---|---|------|---|--|
| 1 pole 3 Step |  F076 |  |  |  |  | A730 | 2 |    1 pole    2 pole   |
| 2 pole | |  |  |  |  | A750 | 3 | |
| 1 pole 4 Step |  F077 |  |  |  |  | A731 | 2 |     1 pole     2 pole     |
| 2 pole | |  |  |  |  | A751 | 4 | |

Multi-step Switches with „OFF“

| | | | | | | | | |
|---|---|---|---|---|---|--|----------------------------|---|
| 1 pole 2 Step 2 pole 3 pole 4 pole 5 pole 6 pole |  F075 |  |  |  |  | A240 A260 A280 WAA480 WAA486 WAA491 | 1 2 3 4 5 6 |       1-6 pole           |
| 1 pole 3 Step 2 pole 3 pole 4 pole 5 pole |  F109 |  |  |  |  | A241 A261 A281 WAA481 WAA487 | 2 3 5 6 8 |    1 and 2 pole     3 pole     4 pole     5 pole             |















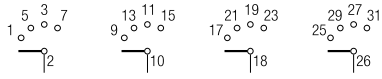











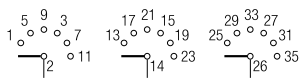
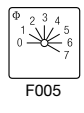



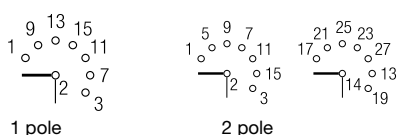





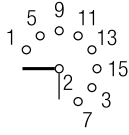



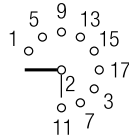
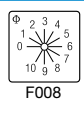

¹Connection diagrams for CHR switches on request.

[< back to table of contents >](#)

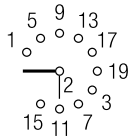
| Function | Escutch. Plate | Type/Handle | | | | Code | Stages | Connection Diagram ¹ |
|----------|----------------|----------------|--------------|----------------|------------------|------|--------|---------------------------------|
| | | CG4- CGD4-1 | CG6- CHR6 | CH10- CHR16 | CH10B- CHR16B | | | |

Multi-step Switches with „OFF“

[Dimensions p. 46](#)

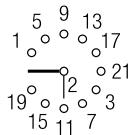
| | | | | | | | | |
|---|---|---|---|---|---|------------------------------------|------------------|---|
| 1 pole 4 Step 2 pole 3 pole 4 pole |  |  |  |  |  | A242 WAA262 WAA282 WAA482 | 2 4 6 8 |  |
| 1 pole 5 Step 2 pole 3 pole |  |  |  |  |  | A243 WAA263 WAA283 | 3 5 8 |  |
| 1 pole 6 Step 2 pole 3 pole |  |  |  |  |  | A244 WAA264 WAA284 | 3 6 9 |  |
| 1 pole 7 Step 2 pole |  |  |  |  |  | WAA245 WAA265 | 4 7 |  |
| 1 pole 8 Step |  |  |  |  |  | WAA246 | 4 |  |
| 1 pole 9 Step |  |  |  |  |  | WAA247 | 5 |  |
| 1 pole 10 Step |  |  |  |  |  | WAA248 | 5 |  |
| 1 pole 11 Step 1 pole 360° rotation |  |  |  |  |  | WAA249 WAA649 | 6 6 |  |











[< back to table of contents >](#)

¹Connection diagrams for CHR switches on request.

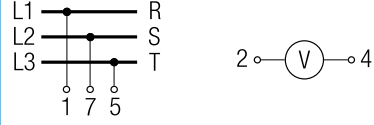





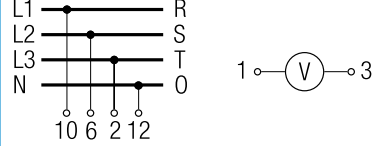



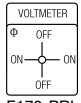

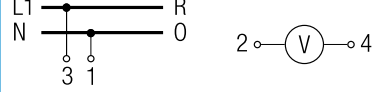

| Function | Escutch. Plate | Type/Handle | | | | Code | Stages | Connection Diagram ¹ |
|----------|----------------|----------------|--------------|----------------|------------------|------|--------|---------------------------------|
| | | CG4- CGD4-1 | CG6- CHR6 | CH10- CHR16 | CH10B- CHR16B | | | |

Voltmeter Switches without „OFF“

[Dimensions p. 46](#)

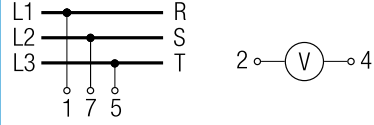
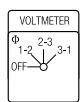
| | | | | | | | | |
|--|---|---|---|---|---|------|------------|---|
| 3 phase 3 wire |  F792 |  |  |  |  | A023 | 2 |  |
| 3 phase 3 wire 3 phase to phase and phase to neutral |  F794 |  |  |  |  | A025 | 3 3 |  |

Voltmeter Switches with „OFF“

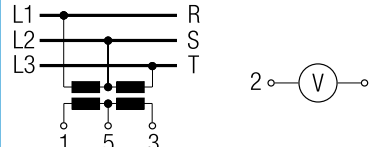
| | | | | | | | | |
|-------------------------|---|---|---|---|---|--------|---|---|
| 2 pole 360° rotation |  F170-PRL |  |  |  |  | WAA002 | 1 |  |
| 3 phase 3 wire |  F775 |  |  |  |  | A004 | 2 |  |
| |  F212-PRL |  |  |  |  | WAA011 | 2 |  |

¹Connection diagrams for CHR switches on request.















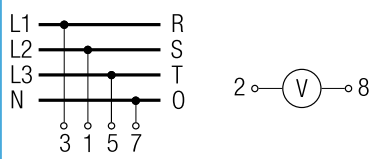





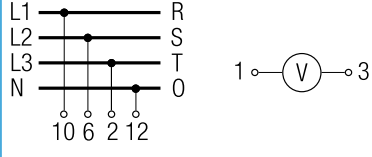

Switch Function and Configuration

CG, CH, CHR Switches

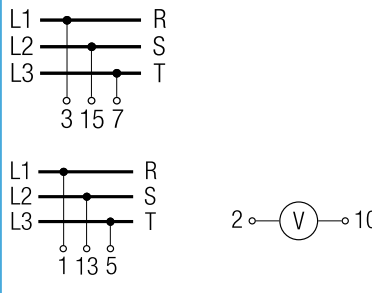
| Function | Escutch. Plate | Type/Handle | | | | Code | Stages | Connection Diagram ¹ |
|----------|----------------|----------------|--------------|----------------|------------------|------|--------|---------------------------------|
| | | CG4- CGD4-1 | CG6- CHR6 | CH10- CHR16 | CH10B- CHR16B | | | |

Voltmeter Switches with „OFF“

[Dimensions p. 46](#)

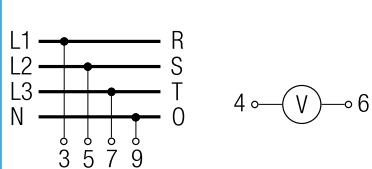













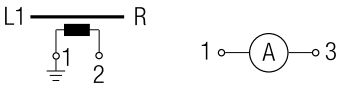

| | | | | | | | | |
|---|---|---|---|---|---|--------|---|---|
| 3 phase to neutral |  F779 |  |  |  |  | WAA005 | 2 |  |
| 3 phase to phase and 3 phase to neutral |  F782 |  |  |  |  | A007 | 3 |  |
| 2 separate 3 phase with center „OFF“ |  F786 |  |  |  |  | WAA008 | 4 |  |
| 3 phase and 1 phase to neutral |  F789 |  |  |  |  | WAA010 | |  |

¹Connection diagrams for CHR switches on request.

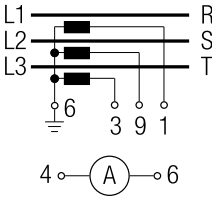
| Function | Escutch. Plate | Type/Handle | | | | Code | Stages | Connection Diagram ¹ |
|----------|----------------|----------------|--------------|----------------|------------------|------|--------|---------------------------------|
| | | CG4- CGD4-1 | CG6- CHR6 | CH10- CHR16 | CH10B- CHR16B | | | |

Ammeter Switches

[Dimensions p. 46](#)

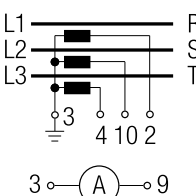









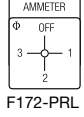



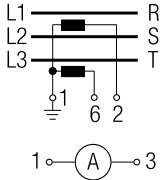
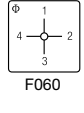



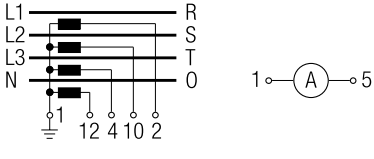
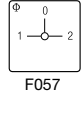





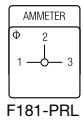

| | | | | | | | | |
|--|---|---|---|---|---|--------|---|--|
| Single pole with one current transformer |  F058 |  |  |  |  | WAA046 | 1 |  |
| Single pole with 3 current transformers without „OFF“ |  F181-PRL |  |  |  |  | WAA017 | |  |
| Single pole with 3 current transformers with „OFF“ 360° rotation |  F059 |  |  |  |  | A048 | 3 |  |

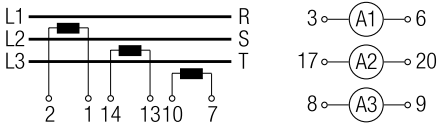
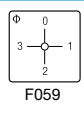
¹Connection diagrams for CHR switches on request.

| Function | Escutch. Plate | Type/Handle | | | | Code | Stages | Connection Diagram ¹ |
|----------|----------------|----------------|--------------|----------------|------------------|------|--------|---------------------------------|
| | | CG4- CGD4-1 | CG6- CHR6 | CH10- CHR16 | CH10B- CHR16B | | | |

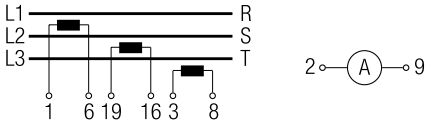
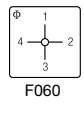
Ammeter Switches

[Dimensions p. 46](#)

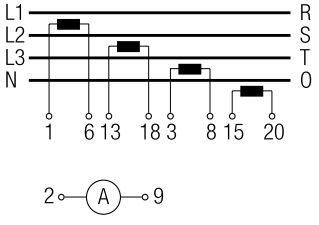
| | | | | | | | | |
|--|---|---|---|---|---|--------|---|---|
| Single pole with 2 current transformers (3 readings) |  F172-PRL |  |  |  |  | WAA021 | 2 |  |
| Single pole with 4 current transformers |  F060 |  |  |  |  | WAA036 | 4 |  |
| 2 pole 2 current transformers |  F057 |  |  |  |  | WAA037 | 3 |  |
| 2 pole 3 current transformers |  F181-PRL |  |  |  |  | WAA019 | 5 |  |
| |  F059 |  |  |  |  | A038 | 5 |  |
| 2 pole 4 current transformers |  F060 |  |  |  |  | WAA039 | 6 |  |















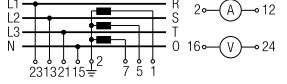

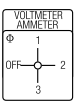

[< back to table of contents >](#)

¹Connection diagrams for CHR switches on request.



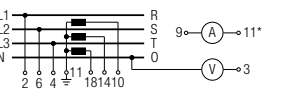
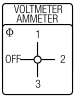



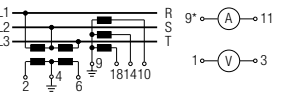







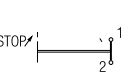





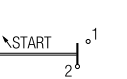





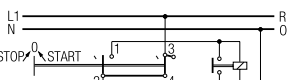





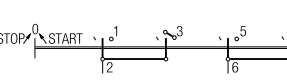

| Function | Escutch. Plate | Type/Handle | | | | Code | Stages | Connection Diagram ¹ |
|----------|----------------|----------------|--------------|----------------|------------------|------|--------|---------------------------------|
| | | CG4- CGD4-1 | CG6- CHR6 | CH10- CHR16 | CH10B- CHR16B | | | |

Volt-ammeter Switches

Dimensions p. 46

| | | | | | | | | |
|--|---|---|---|---|---|--------|---|---|
| 3 phase - phase to phase 3 current |  F101 |  |  |  |  | WAA027 | 6 |  |
| |  F077 |  |  |  |  | WAA028 | 7 |  |
| 3 phase voltage 3 phase current 4 wire |  F174-PRL |  |  |  |  | WAA033 | 5 |  |
| 3 phase voltage 3 phase current 3 wire |  F174-PRL |  |  |  |  | WAA035 | 5 |  |

Control Switches









| | | | | | | | | |
|---|---|---|---|---|---|--------|---|---|
| Stop switch |  F022 |  |  |  |  | WAA174 | 1 |  |
| Start switch |  F023 |  |  |  |  | A175 | 1 |  |
| Stop start switch single pole |  F024 |  |  |  |  | A176 | 1 |  |
| Stop start switch 2 pole |  F024 |  |  |  |  | WAA183 | 2 |  |
| Stop start switch with spring return from start to run |  F119 |  |  |  |  | A178 | 1 |  |
| Stop start switch with spring return to run for 2 units |  F121 |  |  |  |  | WAA177 | 2 |  |

¹Connection diagrams for CHR switches on request.



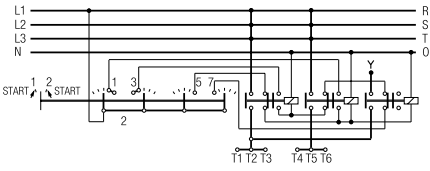
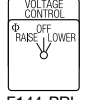



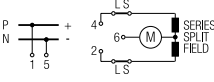



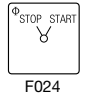



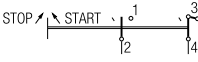





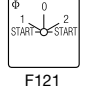

| Function | Escutch. Plate | Type/Handle | | | | Code | Stages | Connection Diagram |
|----------|----------------|----------------|--------------|----------------|------------------|------|--------|--------------------|
| | | CG4- CGD4-1 | CG6- CHR6 | CH10- CHR16 | CH10B- CHR16B | | | |

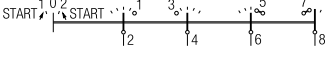
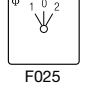
Control Switches



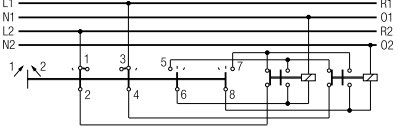
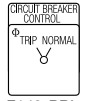



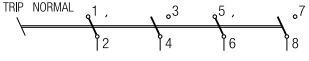



Dimensions p. 46

| | | | | | | | | |
|---|---|---|---|---|---|--------|---|---|
| Stop start switch with spring return to run with contactor interlock contactors for 2 units |  |  |  |  |  | WAA182 | 2 |  |
| Motor voltage control switch |  |  |  |  |  | WAA150 | 2 |  |

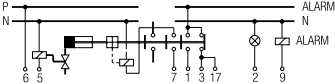
Control Switches with electrically isolated contacts

| | | | | | | | | |
|---|---|---|---|---|---|--------|---|---|
| Stop start switch 1 pole |  |  |  |  |  | A789 | 1 |  |
| Stop start switch with spring return to 1 |  |  |  |  |  | A791 | 1 |  |
| Stop start switch with spring return to run for 2 units |  |  |  |  |  | WAA790 | 2 |  |
| Contactor control with spring return to „OFF“ |  |  |  |  |  | WAA179 | 2 |  |
| Circuit breaker control |  |  |  |  |  | WAA537 | 2 |  |

Control and Alarm Switches¹

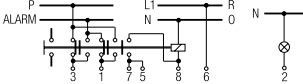









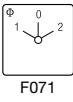



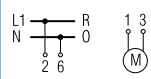
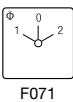

| | | | | | | | | |
|---|---|---|---|---|---|--------|----------------|---|
| With slip clutch and without indicator device |  |  |  |  |  | WAA190 | 5 ² |  |
| Without indicator device |  |  |  |  |  | WAA192 | 2 |  |

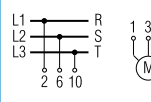
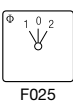
¹Advise the indicator device, described in Catalog 101, page 9. ²incl. slip clutch



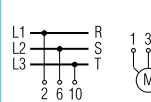
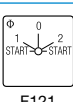



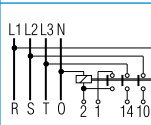

| Function | Escutch. Plate | Type/Handle | | | | Code | Stages | Connection Diagram ¹ |
|----------|----------------|----------------|--------------|----------------|------------------|------|--------|---------------------------------|
| | | CG4- CGD4-1 | CG6- CHR6 | CH10- CHR16 | CH10B- CHR16B | | | |

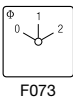
Motor Reversing Switches

[Dimensions p. 46](#)

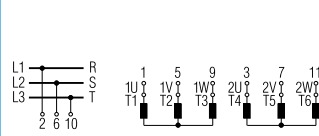
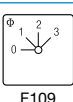
| | | | | | | | | |
|--|---|---|---|---|---|--------|---|---|
| 2 pole |  |  |  |  |  | A400 | 2 |  |
| 3 pole |  |  |  |  |  | A401 | 3 |  |
| 3 pole with spring return to „OFF“ |  |  |  |  |  | A228 | 3 |  |
| 3 pole for use with reversing contactors |  |  |  |  |  | WAA402 | 4 |  |

Motor Control Switches

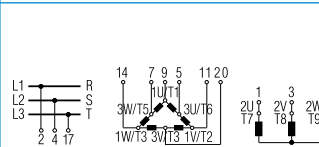









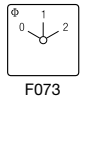



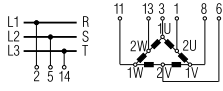
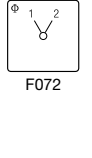



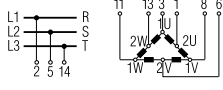
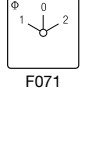



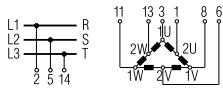
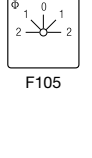

| | | | | | | | | |
|-------------------------------------|---|---|---|---|---|--------|---|---|
| 2 speed 2 winding 0-A-BY or Δ |  |  |  |  |  | WAA451 | 3 |  |
| 3 speed 2 winding 0-AΔ-BY-AY |  |  |  |  |  | WAA457 | 6 |  |

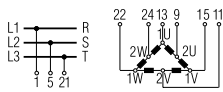
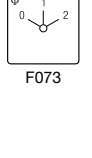
¹Connection diagrams for CHR switches on request.

| Function | Escutch. Plate | Type/Handle | | | | Code | Stages | Connection Diagram ¹ |
|----------|----------------|----------------|--------------|----------------|------------------|------|--------|---------------------------------|
| | | CG4- CGD4-1 | CG6- CHR6 | CH10- CHR16 | CH10B- CHR16B | | | |

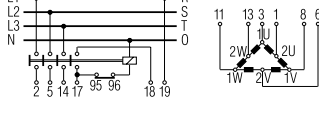
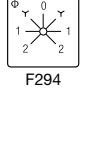
Motor Control Switches

Dimensions p. 46

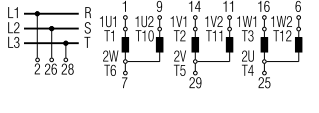













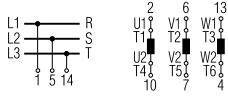





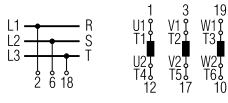

| | | | | | | | | |
|---|---|---|---|---|---|--------|-----------------|---|
| 2 speed single winding |  |  |  |  |  | A440 | 4 |  |
| 2 speed single winding without „OFF“ |  |  |  |  |  | A466 | 4 |  |
| 2 speed single winding with center „OFF“ |  |  |  |  |  | A441 | 4 |  |
| 2 speed single winding reversing |  |  |  |  |  | A442 | 6 |  |
| 2 speed single winding for use with contactors |  |  |  |  |  | WAA444 | 5 |  |
| 2 speed reversing for 2 way operation with slip clutch for „OFF“ load use |  |  |  |  |  | WAA468 | 10 ² |  |

¹Connection diagrams for CHR switches on request. ²incl. slip clutch

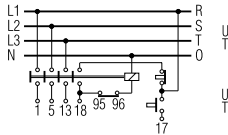
| Function | Escutch. Plate | Type/Handle | | | | Code | Stages | Connection Diagram ¹ |
|----------|-------------------|----------------|--------------|----------------|------------------|------|--------|---------------------------------|
| | | CG4- CGD4-1 | CG6- CHR6 | CH10- CHR16 | CH10B- CHR16B | | | |





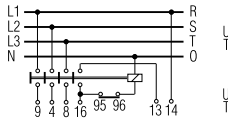









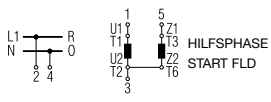

Star-delta Switches

[Dimensions p. 46](#)

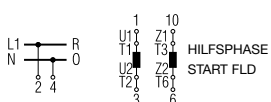
| | | | | | | | | |
|---|---|---|---|---|---|--------|---|--|
| OFF-star-delta |  |  |  |  |  | A410 | 4 |  |
| Reversing |  |  |  |  |  | WAA413 | 5 |  |
| With auxiliary contact closed in „OFF“ position |  |  |  |  |  | WAA416 | 5 |  |
| For use with reversing contactors |  |  |  |  |  | A419 | 4 |  |

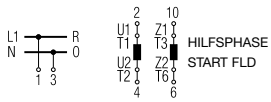

[< back to table of contents >](#)

Start and Run Switches

| | | | | | | | | |
|--|---|---|---|---|---|--------|---|---|
| Split-phase start |  |  |  |  |  | A425 | 2 |  |
| Split-phase start reversing |  |  |  |  |  | WAA426 | 3 |  |
| Split-phase reversing auto cutout of start field winding |  |  |  |  |  | WAA622 | 3 |  |

¹Connection diagrams for CHR switches on request.

| | | | | | |
|--|-----------------------|-------------|----------|-----------|--------------|
| Two or Four Hole Panel Mounting | Terminals rotated 90° | Code | CG4-CHR6 | CG8-CHR16 | CH10B-CHR16B |
|--|-----------------------|-------------|----------|-----------|--------------|

| Panel mounting | | | | | | |
|---|--|---|--------------|--------|--------|--------|
|  | <p>Two hole panel mounting, Protection IP 40</p> | ● | E E-V | ● ● | | |
| | <p>Two hole panel mounting, Protection IP 66/67/69k</p> | ● | EF EF-V | ● ● | | |
|  | <p>Four hole panel mounting, Protection IP 40</p> | ● | E E-V | ● ● | ● ● | ● ● |
| | <p>Four hole panel mounting, Protection IP 66/67/69k</p> | ● | EF EF-V | ● ● | ● ● | ● ● |
| | <p>Two hole panel mounting, Protection IP 66/67/69k</p> | ● | E22 E22-V | ● ● | | |
| Panel mounting using larger escutcheon plate and handle and with heavy duty latching | | | | | | |
|  | <p>Four hole panel mounting, Protection IP 40</p> | | EG | ● | | |
| | <p>Four hole panel mounting, Protection IP 66/67/69k</p> | | EGF | ● | | |

[< back to table of contents >](#)

| | | |
|--|-------------|----------|
| Two Hole Panel Mounting or Mosaic Mounting | Code | CG4-CHR6 |
|--|-------------|----------|

Panel mounting with round shaft for combining with commercial radio knobs



Two hole panel mounting, Protection IP 40
Shaft diam. 6 mm/.24 inch

E9



Two hole panel mounting, Protection IP 40
Shaft diam. 6,35 mm/.25 inch

E91



Mosaic mounting

For Siemens-Mosaic 30 mm grid depth, Protection IP 40

E92



For Subklew-, Kreutzenbeck-, Symo-Mosaic, Protection IP 40
28 mm 25 mm 25 mm grid depth

E93



For Mauell-Mosaic 30 mm grid depth, Protection IP 40

E94



| | | | |
|--|-------------|-----------|--------------|
| Two or Four Hole Panel Mounting | Code | CG8-CHR16 | CH10B-CHR16B |
|--|-------------|-----------|--------------|

| | | | | |
|---|--|------|-----------|---|
|  | <p>Panel mounting with heavy duty latching and metal shaft</p> <p>Four hole panel mounting, Protection IP 40 Mounting plate, escutcheon plate and handle of size S0</p> | KN2 | ● | |
|  | <p>Four hole panel mounting, Protection IP 40 Mounting plate, escutcheon plate and handle of size S1</p> | KN1 | ● | ● |
|  | <p>Four hole panel mounting, Protection IP 40 Mounting plate, escutcheon plate and handle of size S1 and 6 mm square metal shaft</p> | KD1 | ● | ● |
| Panel mounting with protective cover | | | | |
|  | <p>Four hole panel mounting Protection front IP 40 rear IP 30</p> | EC | CH CHR | ● |
|  | <p>Four hole panel mounting with additional shaft seal Protection front IP 65 rear IP 30</p> | ED | CH CHR | ● |
|  | <p>Four hole panel mounting Protection front IP 40 rear IP 42</p> | EC1 | | ● |
|  | <p>Four hole panel mounting with additional shaft seal Protection front IP 66/67/69k rear IP 42</p> | ED1 | | ● |
|  | <p>Two hole panel mounting Protection front IP 66/69k rear IP 42</p> | ED22 | ● | |

[< back to table of contents >](#)

| | | | | |
|----------------------|-----------------------|------|----------|-----------|
| Single Hole Mounting | Terminals rotated 90° | Code | CG4-CHR6 | CG8-CHR16 |
|----------------------|-----------------------|------|----------|-----------|

With locking nut and shaft seal



Without escutcheon plate,
Protection IP 66/67/69k



FS1
FS1-V
FT1
FT1-V
FT3
FT3-V

mm
16/22
16/22

mm
22
22
22/30
22/30



With square escutcheon plate,
Protection IP 66/67/69k



FS2
FS2-V
FT2
FT2-V
FT4
FT4-V

16/22
16/22

22
22
22/30
22/30

With size S1 square escutcheon plate
and heavy duty latching, Protection IP 66/67/69k



FH3
FH3-V

22
22



With rectangular escutcheon plate,
Protection IP 66/67/69k



FS4
FS4-V
FT6
FT6-V

16/22
16/22

22
22

With size S1 rectangular escutcheon plate
and heavy duty latching, Protection IP 66/67/69k



FH4
FH4-V

22
22







Mounting key for locking nut

S00 T170 09

< back to table of contents >

| | | | | |
|----------------------|-----------------------|-------------|------------|-----------|
| Base Mounting | Terminals rotated 90° | Code | CG4-CGD4-1 | CG8-CHR16 |
|----------------------|-----------------------|-------------|------------|-----------|

| Base mounting | | | | | |
|---|---|---|---------------|---|--------|
|  | <p>Base mounting - four hole, Protection IP 40</p> | ● | VE VE-V | | ● ● |
| | <p>For four hole base mounting and with integrated simplified door clutch, Protection IP 65</p> | ● | VF VF-V | | ● ● |
|  | <p>For two hole base mounting, Protection IP 40</p> | ● | VE22 VE22V | | ● ● |
| | <p>For two hole base mounting and with integrated simplified door clutch, Protection IP 65</p> | ● | VF22 VF22V | | ● ● |
|  | <p>Snap-on base mounting for track EN 60715, Protection IP 40</p> | | VE1 | | ● |
|  | <p>Snap-on base mounting for track EN 60715, Escutcheon plate can be fastened by screws at the switch, Protection IP 40</p> | | VE1E | ● | ● |
|  | <p>Snap-on base mounting for track EN 60715, Escutcheon plate fastened by single hole mounting at the switch e.g. for combining with key-lock device, Protection IP 66/67/69k</p> | | VE1F | ● | ● |

[< back to table of contents >](#)

| | | | |
|----------------------|-------------|--------------------|---------------|
| Base Mounting | Code | CG4- CGD4- 1 | CG8- CHR16 |
|----------------------|-------------|--------------------|---------------|

Base mounting



Snap-on base mounting for track EN 60715 with rectangular escutcheon plate for 45 mm standard knock-out, Protection IP 40

VE2



Snap-on base mounting for track EN 60715, both the escutcheon plate for 45 mm standard knock-out and the handle are adjustable in height, Protection IP 40

VE21



< back to table of contents >

Escutcheon Plates



Square and rectangular escutcheon plates are available for each size of switch. The escutcheon plate consists of a frame and a faceplate having the switch positions which is then embossed with hot-foil backing. The escutcheon plate frame is an essential part of the switch and serves as a bearing surface for the handle. If the switch is to be mounted without an escutcheon plate we would recommend for size S1 the handle bearing plate T100-04.

Standard Letterings Available

(Over 500 standard letterings, special letterings upon request.)

30° switching

| | | | | | | | | | | | | | | | | | |
|--|--|--|--|--|--|--|--|--|--|--|--|--|--|--|--|--|--|
| | | | | | | | | | | | | | | | | | |
| | | | | | | | | | | | | | | | | | |
| | | | | | | | | | | | | | | | | | |
| | | | | | | | | | | | | | | | | | |
| | | | | | | | | | | | | | | | | | |
| | | | | | | | | | | | | | | | | | |
| | | | | | | | | | | | | | | | | | |
| | | | | | | | | | | | | | | | | | |

45° switching

| | | | | | | | | | | | | | | | | | |
|--|--|--|--|--|--|--|--|--|--|--|--|--|--|--|--|--|--|
| | | | | | | | | | | | | | | | | | |
| | | | | | | | | | | | | | | | | | |
| | | | | | | | | | | | | | | | | | |
| | | | | | | | | | | | | | | | | | |
| | | | | | | | | | | | | | | | | | |

back to table of contents >

Face plates

60° switching

| | | | | | | | | | | | | | | | | | |
|------|------|------|------|-----------------------|---------------------|---------------------|----------------------|---------------------------|-------------------------------|-----------------|----------------------|----------------|----------------------|---------------------------------|----------------------|-------------------------------|---------------------|
| F070 | F087 | F088 | F089 | F133 HAUPTSCHALTER | F197 GOVERNOR | F198 FRAN TILL | F232 SYNCHROSCOPE | F243 POWERFACTOR METER | F247 VARMETER | F263 OLO ELO | F268 SYNCHROSCOPE | F310 AUS EN | F311 ARRET MARCHE | F323 HUMIDBRYTARE | F328 HUMIDBRYTARE | F352 | F367 MAIN SWITCH |
| F379 | F380 | F470 | F754 | F072 | F163 RAISE LOWER | F164 RAISE LOWER | F192 VOLTMETER | F193 POWERFACTOR METER | F196 VARMETER | F230 | F231 SYNCHROSCOPE | F234 | F244 | F257 | F262 | F264 | F282 |
| F288 | F291 | F313 | F382 | F441 | F705 TRIP NORMAL | F721 | F722 | F750 | F757 REMOTE | F758 | F075 | F076 | F098 | F220 CIRCUIT BREAKER CONTROL | F223 | F356 | F357 |
| F377 | F723 | F071 | F073 | F080 | F081 | F085 | F086 | F090 | F091 | F092 | F093 | F094 | F104 | F194 SYNCHRONIZING | F235 | F237 | F239 VOLTMETER |
| F240 | F241 | F249 | F260 | F269 | F274 | F281 | F290 | F292 | F312 | F314 | F315 | F316 | F324 | F331 | F344 | F354 | F358 |
| F359 | F364 | F370 | F371 | F373 | F381 | F385 | F442 | F444 | F469 | F732 | F735 | F759 | F077 | F100 | F101 | F102 | F309 |
| F342 | F343 | F361 | F362 | F363 | F365 | F366 | F078 | F191 AMMETER | F325 AMMETER | F326 | F720 | F074 | F082 | F096 | F097 | F195 TEMPERATURE INDICATOR | F724 |
| F256 | F079 | F083 | F084 | F095 | F099 | F185 | F190 VOLTMETER | F199 AMMETER | F233 TEMPERATURE INDICATOR | F236 | F238 | F242 | F283 | F725 | F730 | F731 | F736 |
| F737 | | | | | | | | | | | | | | | | | |

[< back to table of contents >](#)

90° switching

| | | | | | | | | | | | | | | | | | |
|-----------------|---------------------|-----------------------|------------------------------|---------------------|------|------|-----------------|-------------------|-----------------|-------------------|-------------------|-------------------|---------------------------|---------------------------|-----------------------|----------------------|-----------------|
| F056 | F063 | F068 | F134 HAUPTSCHALTER | F201 MAIN SWITCH | F251 | F252 | F346 | F456 | F058 | F065 | F069 | F177 WATTMETER | F178 POWERFACTOR METER | F182 | F208 | F253 SYNCHROSCOPE | F254 |
| F340 AMMETER | F360 MAIN SWITCH | F378 HAUPTSCHALTER | F458 | F443 MEET UPS | F700 | F743 | F057 | F061 VOLTMETER | F064 AMMETER | F067 | F171 VOLTMETER | F181 VOLTMETER | F205 WATTMETER | F207 POWERFACTOR METER | F180 SYNCHRONIZING | F320 AMMETER | F349 AMMETER |
| F437 | F445 | F715 | F719 | F059 | F060 | F062 | F066 | F170 VOLTMETER | F172 AMMETER | F173 VOLTMETER | F174 AMMETER | F175 VOLTMETER | F176 WATTMETER | F179 POWERFACTOR METER | F180 SYNCHRONIZING | F186 | F188 |
| F202 | F204 | F206 | F250 PAR. TRANSFER SWITCH | F265 | F266 | F286 | F318 AMMETER | F327 AMMETER | F338 | F339 AMMETER | F425 AMMETER | F716 | F717 | F718 | F726 | F733 | F751 |
| F755 | F756 | | | | | | | | | | | | | | | | |

Miscellaneous

| | | | | | | | | | | | | | | | | | | | | | | | |
|-------------------------|-----------------------|----------------------|----------------------|----------------------|----------------------|---------------------|----------------------|---------------------------|---------------------------|-----------------------|--------------------|-----------------------|------------------|----------------------|-----------------------------|----------------------|-----------------------|------|------|------|------|------|------|
| F119 | F130 | F122 | F126 | F125 | F129 | F225 | F248 | F261 | F341 | F345 | F287 | F123 | F127 | F145 | F146 | F148 | F706 | | | | | | |
| F707 | F245 | F120 | F124 | F128 | F131 | F121 | F132 | F749 | | | | | | | | | | F990 | F991 | F801 | F802 | F803 | F804 |
| F805 MASTER SELECTOR | F806 SPEED CONTROL | F807 SELECTOR | F808 VOLTMETER | F809 GOVERNOR | F810 AMMETER | F811 VOLTMETER | F812 WATTMETER | F813 POWERFACTOR METER | F814 POWERFACTOR METER | F815 SYNCHRONIZING | F816 WARMETER | F817 TEMPMETER | F818 TRANSFER | F819 SYNCHROSCOPE | F820 RF. TRANSFER SWITCH | F821 ISOLATOR | F822 HAUPTSCHALTER | | | | | | |
| F823 WAHLSCHALTER | F824 MAIN SWITCH | F825 HUMIDBRYTARE | F826 ERHETSRYTARE | F827 ERHETSRYTARE | F828 INTERRUPTEUR | F829 TURVAKYTTIN | F830 KALMITEMPARE | F831 INTERRUPTEUR | F832 HAUPTSCHALTER | F833 VOLTMETRE | F834 AMPERMETRE | F835 HOVTSCHAKLARE | F837 HEATER | F838 MAIN SWITCH | F839 INTERRUPTEUR | F840 INTERRUPTEUR | F841 INTERRUPTEUR | | | | | | |

¹INTERRUPTEUR PRINCIPAL, OUVERTURE EN POSITION 0 ²INTERRUPTORE GENERALE, APRIRE SOLO CON MANIGLIA SU 0
³INTERRUPTOR PRINCIPAL, ABRIR ARMARIO SOLO EN POS. "0"

Handles

| Type | Color | Code | Size | | |
|------|-------|------|------|----|----|
| | | | S00 | S0 | S1 |







| Type | Color | Code | Size | | |
|------|-------|------|------|----|----|
| | | | S00 | S0 | S1 |

| | | | | | |
|---|--------------|--------------|--------|--------|--------|
| <p>R-Handle</p>  | black red | G001 G002 | — — | ● ● | ● ● |
| <p>F-Handle</p>  | black red | G221 G222 | ● ● | ● ● | ● ● |
| <p>S-Handle</p>  <p>S0 S1</p> | black red | G301 G302 | — — | ● ● | ● ● |
| <p>P-Handle</p>  <p>S0 S1</p> | black red | G211 G212 | — — | ● ● | ● ● |
| <p>O-Handle</p>  | black red | G321 G322 | — — | — — | ● ● |

| | | | | | |
|---|--------------|--------------|--------|--------|--------|
| <p>I-Handle</p>  <p>S00 S0, S1</p> | black red | G251 G252 | ● ● | ● ● | ● ● |
| <p>B-Handle</p>  | black red | G521 G522 | — — | ● ● | ● ● |
| <p>L-Handle</p>  | black red | G501 G502 | — — | — — | ● ● |
| <p>K-Handle</p>  | black red | G411 G412 | — — | — — | ● ● |

[< back to table of contents >](#)

International Standards and Approvals

| Country | Authority | Mark or Standard | | | | | CH6 | | CHR6 | |
|---|------------------------------------|--|-----|-----------------|-----|-----|-------------------------------|---------------|-----------------------------------|-----------------|
| | | | CG4 | CG4-1 CGD4-1 | CG6 | CG8 | CH10 CH11 CH12 CH10B | CH16 CH16B | CHR10 CHR11 CHR12 CHR10B | CHR16 CHR16B |
| SA | Underwriters Laboratories |  ¹ | | | | | | ● | ● | |
| | |  ² ³ | ● | ● | ● | ● | ● | ● | | |
| Canada | Canadian Standards Association |  ⁵ | ● | CG4-1 | ● | ● | ● | ● | ● | |
| | |  ¹ | | | | | | ● | ● | |
| | |  ² ³ | ● | ● | | | ● | ● | | |
| International Electrical Commission (IEC) Recommendation | | EC 60947 ⁴ | + | + | + | + | + | + | + | |
| China | China Quality Certification Centre |  GB/T14048.3 | ● | CG4-1 | | | CH10 CH10B | ● | CHR10 CHR10B | ● |
| Lloyds Register EMEA | |  | | | | | CH10 CH10B | ● | | |
| ● Switch approved + Switch conforms to requirements | | | | | | | | | | |
| ¹ Approved under the "Component Program" (UL-Recognized Industrial Component). File No. E35541, Category Control No. NLRV2 (U.S.) and NLRV8 (Canada) resp. File No. E60262, Category Control Number NRNT2 (U.S.) and NRNT8 (Canada). | | | | | | | | | | |
| ² Approved under the "Listing Program". File No. E35541, Category Control No. NLRV (U.S.) resp. NLRV7 (Canada). | | | | | | | | | | |
| ³ Switch types CGD4-1, CH11, CH12, CHR11, CHR12 approved under the "Listing Program". File No. E60262, Category Control No. NRNT (U.S.) resp. NRNT7 (Canada). | | | | | | | | | | |
| ⁴ IEC does not operate an approval scheme. | | | | | | | | | | |
| ⁵ File No. 13002, Class No. 3211-05 resp. 4652-04. | | | | | | | | | | |

| | | | | | | |
|-----------------------|-------|-----|---------------|-----------------|---------------|-----------------|
| Selection Data | CG4 | CG6 | CH6 | CHR6 | | |
| | CG4-1 | CG8 | CH10 CH10B | CHR10 CHR10B | CH16 CH16B | CHR16 CHR16B |

| | | | | | | | | | |
|---|---|--|--|--------------------------|--------------------------------------|------|------|------|----|
| Rated Insulation Voltage U_i | IEC 60947-3, EN 60947-3 ¹ VDE 0660 part 107 ¹ | V | 440 | 690 | 690 | 690 | 690 | 690 | |
| | SEV max. | V | 400 | 690 | – | – | – | – | |
| | UL/Canada ² | V | 300 | 300 | 600 | 600 | 600 | 600 | |
| | CEE 24 | V | 380 | 380 | – | – | – | – | |
| | min. voltage | V | on request | | | | | | |
| Rated Impulse Withstand Voltage U_{imp}¹ | | kV | 4 | 6 | 6 | 6 | 6 | 6 | |
| Rated Thermal Current I_U/I_{th} | IEC 60947-3, EN 60947-3 VDE 0660 part 107 | A | 10 | 20 | 20 | 20 | 25 | 25 | |
| | SEV max. | A | 10 | 20 | – | – | – | – | |
| | UL/Canada | A | 10 | 16 | 20 | 20 | 25 | 25 | |
| Rated Operational Current I_e | | | | | | | | | |
| AC-21A | Switching of resistive loads, including moderate overloads | IEC 60947-3, EN 60947-3 VDE 0660 part 107 | A | 10 | 20 | 20 | 20 | 25 | 25 |
| AC-1 | Resistive or low inductive loads | SEV 400 V | A | 10 | – | – | – | – | – |
| | | 500 V | A | – | – | – | – | – | – |
| | | 600 V | A | – | – | – | – | – | – |
| AC-22A | Switching of combined resistive or low inductive loads including moderate overloads | IEC 60947-3 220 V-440 V VDE 0660, 500 V part 107 660 V-690 V | A | 10 | 20 | 20 | 20 | 25 | 25 |
| | | | A | – | 20 | 20 | 20 | 25 | 25 |
| | | | A | – | 16 | 16 | 16 | 25 | 25 |
| AC-15 | Switching of control devices, contactors, valves etc. | IEC 60947-5, EN 60947-5-1 110 V VDE 0660, 220 V-240 V part 200 380 V-440 V | A | 2,5 | 6 | 6 | 6 | 8 | 8 |
| | | | A | 2,5 | 6 | 6 | 6 | 8 | 8 |
| | | | A | 1,5 | 4 | 4 | 4 | 5 | 5 |
| Pilot Duty | UL/Canada ² Heavy | | A300 | A300 | A600 | A600 | A600 | A600 | |
| Ampere Rating Resistive or low inductive loads | UL/Canada ² | A | 10 | 16 (150 V) 10 (300 V) | 20 | 20 | 25 | 25 | |
| Resistive load/Motor load | CEE 24 ² NEMKO/FI ² | A | 4/2 | 10/6 | – | – | – | – | |
| | | A | 6/4 ⁴ | 10/6 | – | – | – | – | |
| Breaking capacity | 220 V-240 V | A | 50 | 150 | 150 | 150 | 200 | 200 | |
| | 380 V-440 V | A | 50 | 150 | 150 | 150 | 200 | 200 | |
| | 660 V-690 V | A | – | 80 | 80 | 80 | 125 | 125 | |
| Power loss per contact at I_U Resistance to vibration Resistance to shock | | W | 0,4/0,7 | 0,8 | 1,4 on request min. 5 g, 30 ms | 1,4 | 2,3 | 2,3 | |
| Short Circuit Protection | Max. fuse size (gG-characteristic) | A | 10 | 25 | 25 | 25 | 35 | 35 | |
| | Rated short-time withstand current (1s-current) | A | 90 | 140 | 200 | 200 | 250 | 250 | |
| Min. Ambient Temperature of Stages | | | -25 °C (valid only without optional extra) | | | | | | |
| Max. Ambient Temperature of Stages^{5,6} | open at 100 % I_U/I_{th} | | 55 °C during 24 hours with peaks up to 60 °C | | | | | | |
| | enclosed at 100 % I_{the} | | 35 °C during 24 hours with peaks up to 40 °C | | | | | | |

¹Valid for lines with grounded common neutral termination, overvoltage category III, pollution degree 3. Values for other supply systems on request.

²International Standards and Approvals, refer to page 35.

³Valid only for max. 4 simultaneously opening contacts.

⁴Valid for CG4 only.

⁵For electromagnetic optional extras see additional data in Catalog 101.

⁶Storage temperature: -40 °C to 85 °C (in case of temperature below -5 °C no shock load permissible).

| | | | | | | |
|-----------------------|-------|-----|---------------|-----------------|-------|-----------------|
| Selection Data | CG4 | CG6 | CH6 | CHR6 | CH16 | CHR16 |
| | CG4-1 | CG8 | CH10 CH10B | CHR10 CHR10B | CH16B | CHR16 CHR16B |

[< back to table of contents >](#)

| Rated Utilization Category | | IEC 60947-3, EN 60947-3 VDE 0660 part 107 | | | | | | | | |
|--|--|--|-----------------|-----------------|------------|------------|------|------------|------|------|
| AC-2 | Slip ring motor starting, reversing and plugging, star-delta starting (CG4-CHR10B) | 3 phase | 220 V-240 V | kW | 2,5 | 4 | 4 | 4 | 5,5 | 5,5 |
| | | 3 pole | 380 V-440 V | | 4,5 | 7,5 | 7,5 | 7,5 | 11 | 11 |
| | | | 500 V | | - | 10 | 10 | 10 | 15 | 15 |
| | | | 660 V-690 V | | - | 10 | 10 | 10 | 13 | 13 |
| AC-3 | Direct-on-line starting, star-delta starting (CH16-CHR16B) | 3 phase | 220 V-240 V | kW | 1,5 | 3 | 3 | 3 | 4 | 4 |
| | | 3 pole | 380 V-440 V | | 2,2 | 5,5 | 5,5 | 5,5 | 7,5 | 7,5 |
| | | | 500 V | | - | 5,5 | 5,5 | 5,5 | 7,5 | 7,5 |
| | | | 660 V-690 V | | - | 5,5 | 5,5 | 5,5 | 7,5 | 7,5 |
| | | 1 phase | 110 V-120 V | kW | 0,3 | 0,6 | 0,6 | 0,6 | 1,5 | 1,5 |
| | | 2 pole | 220 V-240 V | | 0,55 | 2,2 | 2,2 | 2,2 | 3 | 3 |
| | | | 380 V-440 V | | 0,75 | 3 | 3 | 3 | 3,7 | 3,7 |
| | | | 500 V | | - | - | 3 | 3 | 4 | 4 |
| | | | 660 V-690 V | - | - | 3 | 3 | 3,7 | 3,7 | |
| AC-4 | Direct-on-line starting, reversing, plugging and inching | 3 phase | 220 V-240 V | kW | 0,37 | 0,55 | 0,55 | 0,55 | 1,5 | 1,5 |
| | | 3 pole | 380 V-440 V | | 0,55 | 1,5 | 1,5 | 1,5 | 3 | 3 |
| | | | 500 V | | - | 1,5 | 1,5 | 1,5 | 3 | 3 |
| | | | 660 V-690 V | | - | 1,5 | 1,5 | 1,5 | 3 | 3 |
| | | 1 phase | 110 V-120 V | kW | 0,15 | 0,3 | 0,3 | 0,3 | 0,45 | 0,45 |
| | | 2 pole | 220 V-240 V | | 0,25 | 0,75 | 0,75 | 0,75 | 1,1 | 1,1 |
| | | | 380 V-440 V | | 0,5 | 1,5 | 1,5 | 1,5 | 2,2 | 2,2 |
| | | | 500 V | | - | - | - | - | - | - |
| | | | 660 V-690 V | - | - | - | - | - | | |
| AC-23A | Frequent switching of motors or other high inductive loads | 3 phase | 220 V-240 V | kW | 1,8 | 3,7 | 3,7 | 3,7 | 5,5 | 5,5 |
| | | 3 pole | 380 V-440 V | | 3 | 7,5 | 7,5 | 7,5 | 11 | 11 |
| | | | 500 V | | - | 7,5 | 7,5 | 7,5 | 11 | 11 |
| | | | 660 V-690 V | | - | 7,5 | 7,5 | 7,5 | 11 | 11 |
| | | 1 phase | 110 V-120 V | kW | 0,37 | 0,75 | 0,75 | 0,75 | 1,5 | 1,5 |
| | | 2 pole | 220 V-240 V | | 0,75 | 2,5 | 2,5 | 2,5 | 3 | 3 |
| | | | 380 V-440 V | | 1,1 | 3,7 | 3,7 | 3,7 | 5,5 | 5,5 |
| | | | 500 V | | - | - | 4 | 4 | 5,5 | 5,5 |
| | | | 660 V-690 V | - | - | 4 | 4 | 5,5 | 5,5 | |
| Ratings | Standard motor load DOL-Rating (similar AC-3) | 3 phase | 110 V-120 V | HP | 0,75 | 1,5 | 1,5 | 1,5 | 2 | 2 |
| | | 3 pole | 220 V-240 V | | 1 | 1 | 3 | 3 | 5 | 5 |
| | | | 440 V-600 V | | - | - | 5 | 5 | 10 | 10 |
| | | | | | | | | | | |
| | | 1 phase | 110 V-120 V | HP | 0,33 | 0,5 | 0,5 | 0,5 | 1 | 1 |
| | | 2 pole | 220 V-240 V | | 0,75 | 1 | 1 | 1 | 2 | 2 |
| | | | 277 V | | 0,75 | 1 | 2 | 2 | 3 | 3 |
| | | | 440 V-600 V | | - | - | 2 | 2 | 5 | 5 |
| Heavy motor load Reversing-Rating (similar AC-4) | | 3 phase | 110 V-120 V | HP | - | 0,5 | 0,5 | 0,5 | 1 | 1 |
| | | 3 pole | 220 V-240 V | | - | 1 | 1 | 1 | 2 | 2 |
| | | | 440 V-600 V | | - | - | 3 | 3 | 5 | 5 |
| | | | | | | | | | | |
| | | 1 phase | 110 V-120 V | HP | - | 0,17 | 0,17 | 0,17 | 0,33 | 0,33 |
| | | 2 pole | 220 V-240 V | | - | 0,5 | 0,5 | 0,5 | 0,75 | 0,75 |
| | | | 277 V | | - | 0,5 | 0,6 | 0,6 | 1 | 1 |
| | | | 440 V-600 V | | - | - | 1,5 | 1,5 | 2 | 2 |
| Max. Permissible Wire Gage - Use copper wire only | Single-core or stranded wire | mm ² | | mm ² | 2x1,5 | 2x2,5 | 2x4 | | 2x4 | |
| | | AWG | 2x14 | | 2x12 | 2x10 | | 2x10 | | |
| | | Flexible wire (sleeving in accordance with DIN 46228) | mm ² | 2x1,5(1) | 2x2,5(2,5) | 2x2,5(2,5) | | 2x2,5(2,5) | | |
| | | Flexible AWG wires (without sleeve) | AWG | 2x16 | 2x14 | 2x12 | | 2x12 | | |
| | | Connection with insulated ring and fork type terminals | mm | | | | | ≥3,6 | | ≥3,6 |
| | | Internal diameter | mm | | | | | ≤8,6 | | ≤8,6 |
| | | External diameter | mm | | | | | 6,3 | | 6,3 |
| | | Connection with quick connect terminations | mm | | | | | | | |

| | | | | | |
|-----------------------|--------|------|-------|------|-------|
| Selection Data | CGD4-1 | CH11 | CHR11 | CH12 | CHR12 |
|-----------------------|--------|------|-------|------|-------|

| | | | | | | | | | |
|---|--|--|-----------------|--|----------------|----------------|------------|----------|----------|
| Rated Insulation Voltage U_i | | IEC 60947-3, EN 60947-3 ¹ VDE 0660 part 107 ¹ | V | 440 | 600 | 600 | 600 | 600 | |
| | | North America | V | 300 | 300 | 300 | 300 | 300 | |
| | | min. voltage | V | 1 ⁴ | 1 ⁴ | 1 ⁴ | 6 | 6 | |
| Rated Impulse Withstand Voltage U_{imp} | | | | on request | | | | | |
| Rated Thermal Current I_U/I_{th} | | IEC 60947-3, EN 60947-3 VDE 0660 part 107 | A | 5 | 6 | 6 | 6 | 6 | |
| | | North America | A | 5 | 6 | 6 | 6 | 6 | |
| Rated Operational Current I_e | | IEC 60947-3, EN 60947-3 VDE 0660 part 107 | | | | | | | |
| AC-21A | Switching of resistive loads, including moderate overloads | North America ² | 1 V/6 V | A | 5/2 | 6/3 | 6/3 | -/6 | -/6 |
| | | | 12 V/24 V | A | 1,2/0,7 | 2/1 | 2/1 | 6/5 | 6/5 |
| | | | 48 V/60 V | A | 0,45/- | 0,8/0,7 | 0,8/0,7 | 4/3,5 | 4/3,5 |
| | | | 110 V | A | 0,25 | 0,4 | 0,4 | 3 | 3 |
| | | | 240 V | A | 0,15 | 0,2 | 0,2 | 1,8 | 1,8 |
| | | | 300 V | A | 0,13 | 0,13 | 0,13 | 1,3 | 1,3 |
| | | | 440 V | A | 0,1 | 0,1 | 0,1 | 1 | 1 |
| | | | 500 V | A | - | 0,08 | 0,08 | 0,8 | 0,8 |
| | | | 600 V | A | - | 0,05 | 0,05 | 0,5 | 0,5 |
| Power loss per contact at I_U | | | W | 0,4 | 0,4 | 0,4 | 0,2 | 0,2 | |
| Short Circuit Protection | | | | | | | | | |
| Max. fuse size | | (glass-tube, quick) | A | 5 | 6 | 6 | 6 | 6 | |
| Rated short-time withstand current | | (1s-current) | A | 30 | 35 | 35 | 50 | 50 | |
| DC Switching Capacity⁵ | | IEC 60947-3, EN 60947-3 VDE 0660 part 107 | | | | | | | |
| DC-21B | Resistive load $T \leq 1$ ms | North America ² | 1 V/6 V | A | 3/1,2 | 4/2,5 | 4/2,5 | -/4 | -/4 |
| | | | 12 V/24 V | A | 0,7/0,4 | 1,5/0,8 | 1,5/0,8 | 3/2,2 | 3/2,2 |
| | | | 48 V/60 V | A | 0,25/0,2 | 0,3/0,27 | 0,3/0,27 | 1,2/1 | 1,2/1 |
| | | | 110 V/240 V | A | 0,13/0,08 | 0,2/0,1 | 0,2/0,1 | 0,6/0,3 | 0,6/0,3 |
| | | | 300 V/440 V | A | 0,07/0,05 | 0,07/0,05 | 0,07/0,05 | 0,2/0,15 | 0,2/0,15 |
| | | | 500 V/600 V | A | - | 0,03/0,02 | 0,03/0,02 | 0,1/0,1 | 0,1/0,1 |
| Max. Permissible Wire Gage - Use copper wire only | | | | | | | | | |
| Single-core or stranded wire | | | mm ² | 2x1,5 | 2x4 | | 2x4 | | |
| | | | AWG | 2x14 | 2x10 | | 2x10 | | |
| Flexible wire (sleeving in accordance with DIN 46228) | | | mm ² | 2x1,5(1) | 2x2,5(2,5) | | 2x2,5(2,5) | | |
| Flexible AWG wires (without sleeve) | | | AWG | 2x16 | 2x12 | | 2x12 | | |
| Connection with insulated ring and fork type terminals | | | mm | | | ≥3,6 | | ≥3,6 | |
| Internal diameter | | | mm | | | ≤8,6 | | ≤8,6 | |
| External diameter | | | mm | | | 6,3 | | 6,3 | |
| Connection with quick connect terminations | | | mm | | | | | | |
| Max. Ambient Temperature of Stages | | | | -25 °C (valid only without optional extra) | | | | | |
| Max. Ambient Temperature of Stages^{3, 6} | | open at 100 % I_U/I_{th} | | 55 °C during 24 hours with peaks up to 60 °C | | | | | |
| | | enclosed at 100 % I_{the} | | 35 °C during 24 hours with peaks up to 40 °C | | | | | |

[< back to table of contents >](#)

¹Valid for lines with grounded common neutral termination, overvoltage category III, pollution degree 3. Values for other supply systems on request.
²max. 300 V. ³For electromagnetic optional extras see additional data in Catalog 101. ⁴Values for lower voltages on request. ⁵Values for switches with spring return on request. ⁶Storage temperature: -40 °C to 85 °C (in case of temperature below -5 °C no shock load permissible).

| | | | | | | |
|-----------------------|-------|-----|---------------|-----------------|-------|-----------------|
| Selection Data | CG4 | CG6 | CH6 | CHR6 | CH16 | CHR16 |
| | CG4-1 | CG8 | CH10 CH10B | CHR10 CHR10B | CH16B | CHR16 CHR16B |

| Tightening torque of screws | | Nm | 0,4 | 0,8 | 1,2 | 1,4 | 1,2 | 1,4 |
|---|------------------------------|--|-----|------|------|------|-----|-----|
| | | lb-in | 3,5 | 7 | 10 | 12 | 10 | 12 |
| DC Switching Capacity¹ | | Rated Thermal Current I_e | | | | | | |
| Kontakte in Serie: | 1 2 3 4 5 6 8 | | | | | | | |
| | Permissible voltage in volts | | | | | | | |
| Utilization category | 24 48 72 96 120 144 192 | A | 10 | 16 | 16 | 16 | 21 | 21 |
| DC-21A, DC-21B | 48 96 144 192 240 288 384 | A | 6 | 14 | 14 | 14 | 18 | 18 |
| Switching of resistive load | 60 120 180 240 300 360 480 | A | 5 | 13 | 13 | 13 | 17 | 17 |
| Time constant L/R≤1ms | 110 220 330 440 550 660 - | A | 4 | 6 | 6 | 6 | 6 | 6 |
| | 220 440 660 - - - - | A | 0,8 | 0,9 | 0,9 | 0,9 | 1 | 1 |
| Utilization category | 24 48 72 96 120 144 192 | A | 8 | 14 | 14 | 14 | 18 | 18 |
| DC-22A, DC-22B | 48 96 144 192 240 288 384 | A | 5 | 13 | 13 | 13 | 17 | 17 |
| Switching of mixed resistive and inductive load | 60 120 180 240 300 360 480 | A | 4 | 12 | 12 | 12 | 16 | 16 |
| f.e. shunt motors | 110 220 330 440 550 660 - | A | 1,5 | 1,9 | 1,9 | 1,9 | 2 | 2 |
| Time constant L/R≤2,5ms | 220 440 660 - - - - | A | 0,3 | 0,3 | 0,3 | 0,3 | 0,3 | 0,3 |
| Utilization category | 24 48 72 96 120 144 192 | A | 7 | 13 | 13 | 13 | 16 | 16 |
| DC-23A, DC-23B | 48 96 144 192 240 288 384 | A | 4 | 12 | 12 | 12 | 15 | 15 |
| Switching of highly inductive loads | 60 120 180 240 300 360 480 | A | 3,5 | 10 | 10 | 10 | 14 | 14 |
| f.e. series motors | 110 220 330 440 550 660 - | A | 1 | 1,5 | 1,5 | 1,5 | 1,7 | 1,7 |
| Time constant L/R≤15ms | 220 440 660 - - - - | A | 0,2 | 0,2 | 0,2 | 0,2 | 0,2 | 0,2 |
| Utilization category | 24 48 - - - - - | A | 0,8 | 3 | 3 | 3 | - | - |
| DC-13 | 48 96 - - - - - | A | 0,5 | 1,7 | 1,7 | 1,7 | - | - |
| Control of electromagnets | 60 120 - - - - - | A | 0,2 | 1,4 | 1,4 | 1,4 | - | - |
| Time constant L/R≤100ms | 110 220 - - - - - | A | - | 0,7 | 0,7 | 0,7 | - | - |
| | 220 440 - - - - - | A | - | 0,15 | 0,15 | 0,15 | - | - |

¹Values for switches with spring return on request.

Two or Four Hole Panel Mounting

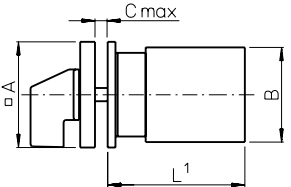

E
for
CG4-CGD4-1
CH6/CHR6
E-V
for
CG6

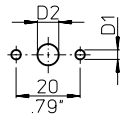

E
E-V
for
CG4-CGD4-1
CH6/CHR6
E
for
CG6

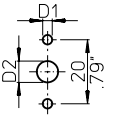

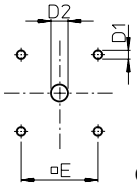

| | CG4 CG4-1 CGD4-1 | CG6 | CG8 | CH6 CHR6 | CH10- CHR16 | CH10B- CHR16B |
|-----------|------------------------|-----------------|-----------------|-----------------|-----------------|------------------|
| A | 30 1.18 | 30 1.18 | 48 1.89 | 30 1.18 | 48 1.89 | 64 2.52 |
| B | 28 1.10 | 38 1.50 | 38 1.50 | 46 1.81 | 46 1.81 | 56 2.20 |
| C | 4 .16 | 4 .16 | 4 .16 | 4 .16 | 4 .16 | 4 .16 |
| D1 | 3,2 .13 | 3,2 .13 | 5 .20 | 3,2 .13 | 5 .20 | 5 .20 |
| D2 | 8-11 .31-.43 | 8-11 .31-.43 | 8-19 .31-.75 | 8-19 .31-.75 | 8-19 .31-.75 | 10-22 .39-.87 |
| E | - | - | 36 1.42 | - | 36 1.42 | 48 1.89 |

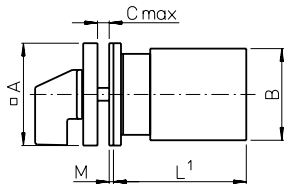

EF
for
CG4-CGD4-1
CH6/CHR6
EF-V
for
CG6

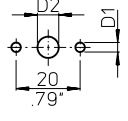

EF-V
for
CG4-CGD4-1
CH6/CHR6
EF
for
CG6

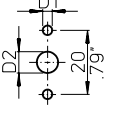

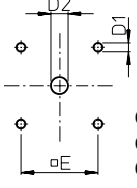

| | CG4 CG4-1 CGD4-1 | CG6 | CG8 | CH6 CHR6 | CH10- CHR16 | CH10B- CHR16B |
|-----------|------------------------|-----------------|------------------|-----------------|------------------|------------------|
| A | 30 1.18 | 30 1.18 | 48 1.89 | 30 1.18 | 48 1.89 | 64 2.52 |
| B | 28 1.10 | 38 1.50 | 38 1.50 | 46 1.81 | 46 1.81 | 56 2.20 |
| C | 4 .16 | 4 .16 | 4 .16 | 4 .16 | 4 .16 | 4 .16 |
| D1 | 3,2 .13 | 3,2 .13 | 5 .20 | 3,2 .13 | 5 .20 | 5 .20 |
| D2 | 8-11 .31-.43 | 8-11 .31-.43 | 15-19 .59-.75 | 8-11 .31-.43 | 15-19 .59-.75 | 19-22 .75-.87 |
| E | - | - | 36 1.42 | - | 36 1.42 | 48 1.89 |
| M | 1 .04 | 1 .04 | - | 1 .04 | - | - |

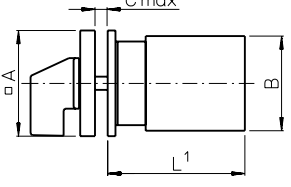

E22
for
CG
E22-V
for
CH/CHR

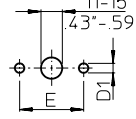

E22-V
for
CG
E22
for
CH/CHR

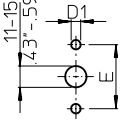

| | CG8 | CH10- CHR16 |
|-----------|------------|----------------|
| A | 48 1.89 | 48 1.89 |
| B | 38 1.50 | 46 1.81 |
| C | 4 .16 | 4 .16 |
| D1 | 5 .20 | 5 .20 |
| E | 30 1.17 | 30 1.17 |

¹see page 46

Two or Four Hole Panel Mounting

EC
ED
EC1
ED1

ED22

| | CG8 | CH10- CHR16 | CH10B- CHR16B |
|-----------|------------------|------------------|------------------|
| | ED22 | EC ED | EC ED |
| A | 48 1.89 | 64 2.52 | 64 2.52 |
| B | 74 2.91 | 68 2.68 | 74 2.91 |
| C | - | 4 .16 | 4 .16 |
| C | 4 .16 | 4 .16 | 4 .16 |
| D1 | 5 .20 | 5 .20 | 5 .20 |
| D2 | - | 10-19 .39-.75 | 10-22 .39-.87 |
| D2 | 11-15 .43-.59 | 19-22 .75-.87 | 11-15 .43-.59 |
| E | - | 48 1.89 | 48 1.89 |
| F | 30 1.17 | - | 30 1.17 |
| M | 1,5 .06 | - | 1,5 .06 |
| 1 | 74,3 2,93 | - | 74,3 2,93 |
| 2 | 74,3 2,93 | - | 74,3 2,93 |
| 3 | 94,3 3,71 | - | 94,3 3,71 |
| 4 | 94,3 3,71 | 104 4,10 | 94,3 3,71 |
| 5 | 94,3 3,71 | - | 127 5,00 |
| 6 | - | - | 139,5 5,49 |
| 7 | - | - | 164,5 6,48 |
| 8 | - | - | 177 6,97 |
| 9 | - | - | - |
| 10 | - | - | - |

< back to table of contents >

Four Hole Panel Mounting or Single Hole Mounting

**KN1
KD1
KN2**

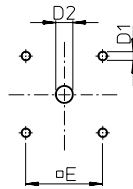
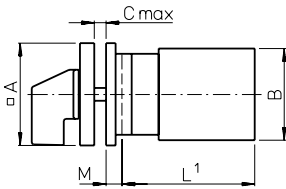

| | KN2 | | | KN1 KD1 | |
|-----------|-----------------|-----------------|-----------|--------------------|------------------|
| | CG8 | CH10- CHR16 | | CG8 | CH10- CHR16 |
| A | 48 1.89 | 48 1.89 | A | 64 2.52 | 64 2.52 |
| B | 38 1.50 | 46 1.81 | B | 38 1.50 | 46 1.81 |
| C | 4 .16 | 4 .16 | C | 4 .16 | 4 .16 |
| D1 | 5 .20 | 5 .20 | D1 | 5 .20 | 5 .20 |
| D2 | 8-19 .31-.75 | 8-19 .31-.75 | D2 | 10-22 .39-.87 | 10-22 .39-.87 |
| E | 36 1.42 | 36 1.42 | E | 48 1.89 | 48 1.89 |
| M | 5,2 .20 | 5,2 .20 | M | 4,7 .19 | 7 .28 |

< back to table of contents >

**FS1...
FT1...
FT3...**

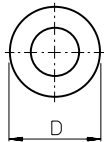

**FH3...
FS2...
FT2...
FT4...**



**FH4...
FS4...
FT6...**

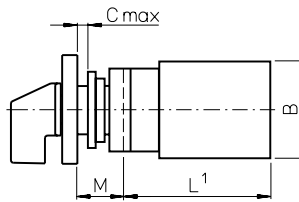
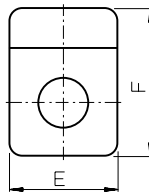

**FS1...
FS2...
FS4...**

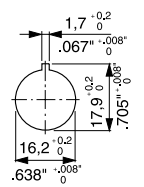

**FH3...
FH4...
FT1...
FT2...
FT6...**

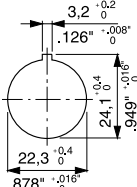

**FT3...
FT4...**

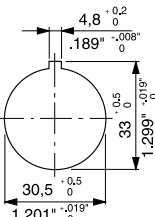
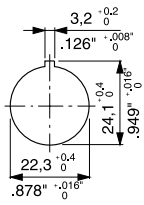
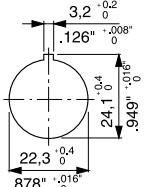

| | CG4 | | CG8 | CH6 CHR6 | CH10- CHR16 |
|---------------|-----------------|--------------|--------------|--------------|----------------|
| | CG4-1 CGD4-1 | CG6 | | | |
| A/E | 30 1.18 | 30 1.18 | 48 1.89 | 30 1.18 | 48 1.89 |
| FH3... | - | - | 64 2.52 | - | 64 2.52 |
| FH4... | - | - | 64 2.52 | - | 64 2.52 |
| B | 28 1.10 | 38 1.50 | 38 1.50 | 46 1.81 | 46 1.81 |
| C | 5 .20 | 5 .20 | 6 .24 | 5 .20 | 6 .24 |
| D | 29,5 1.16 | 29,5 1.16 | 39,4 1.55 | 29,5 1.16 | 39,4 1.55 |
| F | 39 1.54 | 39 1.54 | 59 2.32 | 39 1.54 | 59 2.32 |
| FH4... | - | - | 78,5 3.09 | - | 78,5 3.09 |
| M | 12,5 .49 | 12,5 .49 | 18,2 .72 | 12,5 .49 | 18,2 .72 |
| FH3... | - | - | 25,2 .99 | - | 25,2 .99 |
| FH4... | - | - | 25,2 .99 | - | 25,2 .99 |

¹see page 46

Base Mounting

VE
VE-V

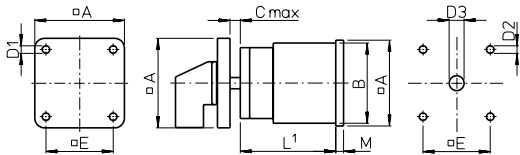

VF
VF-V

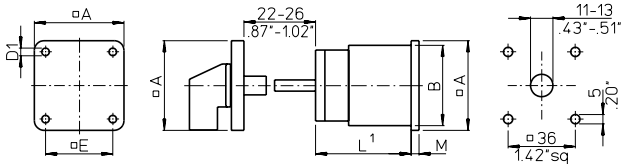

VE22
VE22V

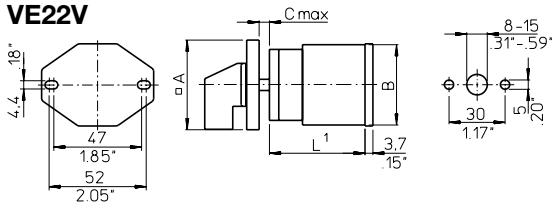

VF22
VF22V

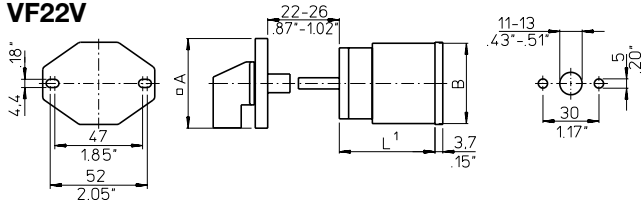

| | CG8 | CH10-CHR16 |
|----------------|-----------------|------------------------|
| A ² | 48 1.89 | 48 (64) 1.89 (2.52) |
| B | 38 1.50 | 46 1.81 |
| C | 10,5 .41 | 10,5 .41 |
| D1 | 4,1 .16 | 4,1 .16 |
| D2 | 5 .20 | 5 .20 |
| D3 | 8-15 .31-.59 | 8-15 .31-.59 |
| E ² | 36 1.42 | 36 (48) 1.42 (1.89) |
| M | 2,2 .09 | 5,2 .20 |

²Dimensions in () for revertive mounting plate

VE1

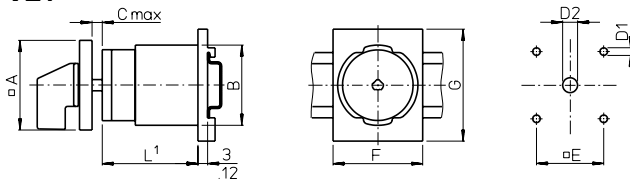

VE1E

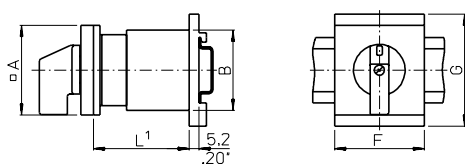

VE1F

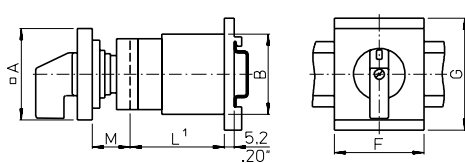

| | CG4 CG4-1 CGD4-1 CG8 | CH10-CHR16 |
|----|----------------------------|-----------------|
| A | 30 1.18 | 48 1.89 |
| B | 28 1.10 | 38 1.50 |
| C | - | 10,5 .41 |
| D1 | - | 5 .20 |
| D2 | - | 8-15 .31-.59 |
| E | - | 36 1.42 |
| F | 35,5 1.40 | 48 1.89 |
| G | 60 2.36 | 60 2.36 |
| M | 12,5 .49 | 20 .79 |

¹see page 46

Base Mounting and Escutcheon Plates

VE2

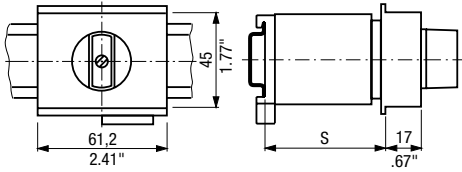

VE21

for CG4-CGD4-1

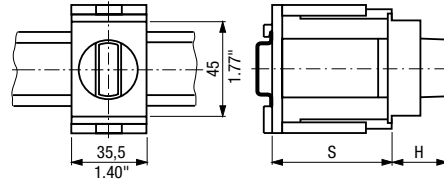

VE21

for CG8-CHR16

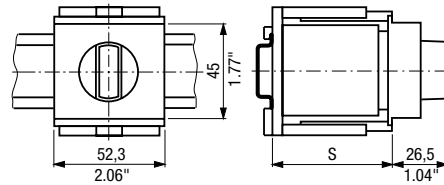

< back to table of contents >

| VE2 | | |
|--|--------------------|------------|
| | CG8 | CH10-CHR16 |
| | Max. no. of stages | |
| S = ⁴⁶ _{1.81} | 1 | 1 |
| S = ⁵⁰ _{1.97} | 2 | 2 |
| S = ⁶¹ _{2.40} | 3 | - |
| S = ⁶⁷ _{2.64} | - | 3 |
| S = ⁶⁹ _{2.70} | - | - |

| VE21 | | CG4-CGD4-1 CG8 CH10-CHR16 | | |
|-------------------------|--------------|---------------------------|---|---|
| S_{min.} | H | No. of stages | | |
| 44 1.73 | 21 .83 | 1 | 1 | 1 |
| 46 1.81 | 26,5 1.04 | 2 | 2 | - |
| 50 1.97 | - | - | - | 2 |
| 54 2.13 | - | - | - | - |
| 60 2.36 | - | - | 3 | - |
| 62 2.44 | 26,5 1.04 | 3 | - | - |
| 64 2.52 | - | - | - | 3 |
| 72 2.83 | - | - | 4 | - |

Escutcheon plates for mounting E, EF, EG, EGF, KN1, KD1, KN2, EC, EC1, ED, ED1, VE, VE1, VF

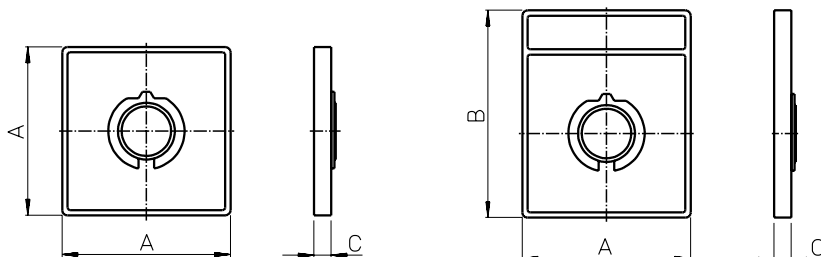

| Size | A | B | C |
|------------|------------|------------|------------|
| S00 | 30 1.18 | 39 1.54 | 5,5 .22 |
| S0 | 48 1.89 | 59 2.32 | 6,7 .26 |
| S1 | 64 2.52 | 78 3.07 | 7,4 .29 |

Additional Lengths

Additional lengths for amendment (page 6)

| | CG8 | CH10 CH16 | CHR10 CHR16 |
|-------------|-------------|--------------|----------------|
| B | 6,2 .24 | 6,2 .24 | 6,2 .24 |
| S | 17,3 .68 | 17,3 .68 | 17,3 .68 |
| L, M | 24,8 .98 | 24,8 .98 | 24,8 .98 |
| X | 23,3 .92 | 23,3 .92 | 23,3 .92 |

Quick connect terminations (plug 2,8 mm or 6,35 mm) for CH switches (page 6)

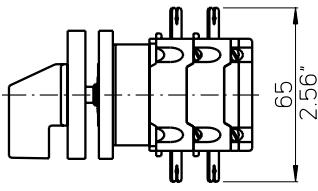

with quick connects

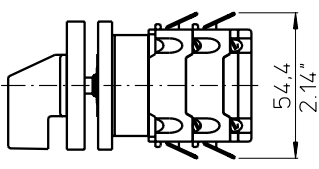

with angled quick connects

Length L

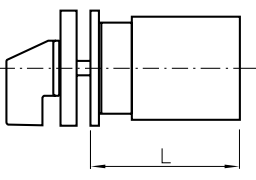

| Stages | CG4 | | CG8 | CH6 CHR6 | CH10 | CHR10 | CH10B CH16B | CHR10B CHR16B |
|-----------|-----------------|------|-------|-------------|----------------------|-------------------------|----------------|------------------|
| | CG4-1 CGD4-1 | CG6 | | | CH11 CH12 CH16 | CHR11 CHR12 CHR16 | | |
| 1 | 38,5 | 43,2 | 40,7 | 46 | 43,5 | 43,5 | 48,9 | 48,9 |
| | 1.52 | 1.70 | 1.60 | 1.81 | 1.71 | 1.71 | 1.93 | 1.93 |
| 2 | 50,5 | 55,9 | 53,4 | 60 | 57,5 | 57,5 | 62,9 | 62,9 |
| | 1.99 | 2.20 | 2.10 | 2.36 | 2.26 | 2.26 | 2.48 | 2.48 |
| 3 | 62,5 | 68,6 | 66,1 | 74 | 71,5 | 71,5 | 76,9 | 76,9 |
| | 2.46 | 2.70 | 2.60 | 2.91 | 2.81 | 2.81 | 3.03 | 3.03 |
| 4 | 74,5 | 81,3 | 78,8 | 88 | 85,5 | 85,5 | 90,9 | 90,9 |
| | 2.93 | 3.20 | 3.10 | 3.46 | 3.37 | 3.37 | 3.58 | 3.58 |
| 5 | 86,5 | - | 91,5 | - | 99,5 | 99,5 | 104,9 | 104,9 |
| | 3.41 | - | 3.60 | - | 3.92 | 3.92 | 4.13 | 4.13 |
| 6 | 98,5 | - | 104,2 | - | 113,5 | 113,5 | 118,9 | 118,9 |
| | 3.88 | - | 4.10 | - | 4.47 | 4.47 | 4.68 | 4.68 |
| 7 | 110,5 | - | 116,9 | - | 127,5 | 127,5 | 132,9 | 132,9 |
| | 4.35 | - | 4.60 | - | 5.02 | 5.02 | 5.23 | 5.23 |
| 8 | 122,5 | - | 129,6 | - | 141,5 | 141,5 | 146,9 | 146,9 |
| | 4.82 | - | 5.10 | - | 5.57 | 5.57 | 5.78 | 5.78 |
| 9 | - | - | 142,3 | - | 155,5 | 155,5 | 160,9 | 160,9 |
| | - | - | 5.60 | - | 6.12 | 6.12 | 6.34 | 6.34 |
| 10 | - | - | 155 | - | 169,5 | 169,5 | 174,9 | 174,9 |
| | - | - | 6.10 | - | 6.67 | 6.67 | 6.89 | 6.89 |
| 11 | - | - | 167,7 | - | 183,5 | 183,5 | 188,9 | 188,9 |
| | - | - | 6.60 | - | 7.22 | 7.22 | 7.44 | 7.44 |
| 12 | - | - | 180,4 | - | 197,5 | 197,5 | 202,9 | 202,9 |
| | - | - | 7.10 | - | 7.77 | 7.77 | 7.99 | 7.99 |

< back to table of contents >

Notes:

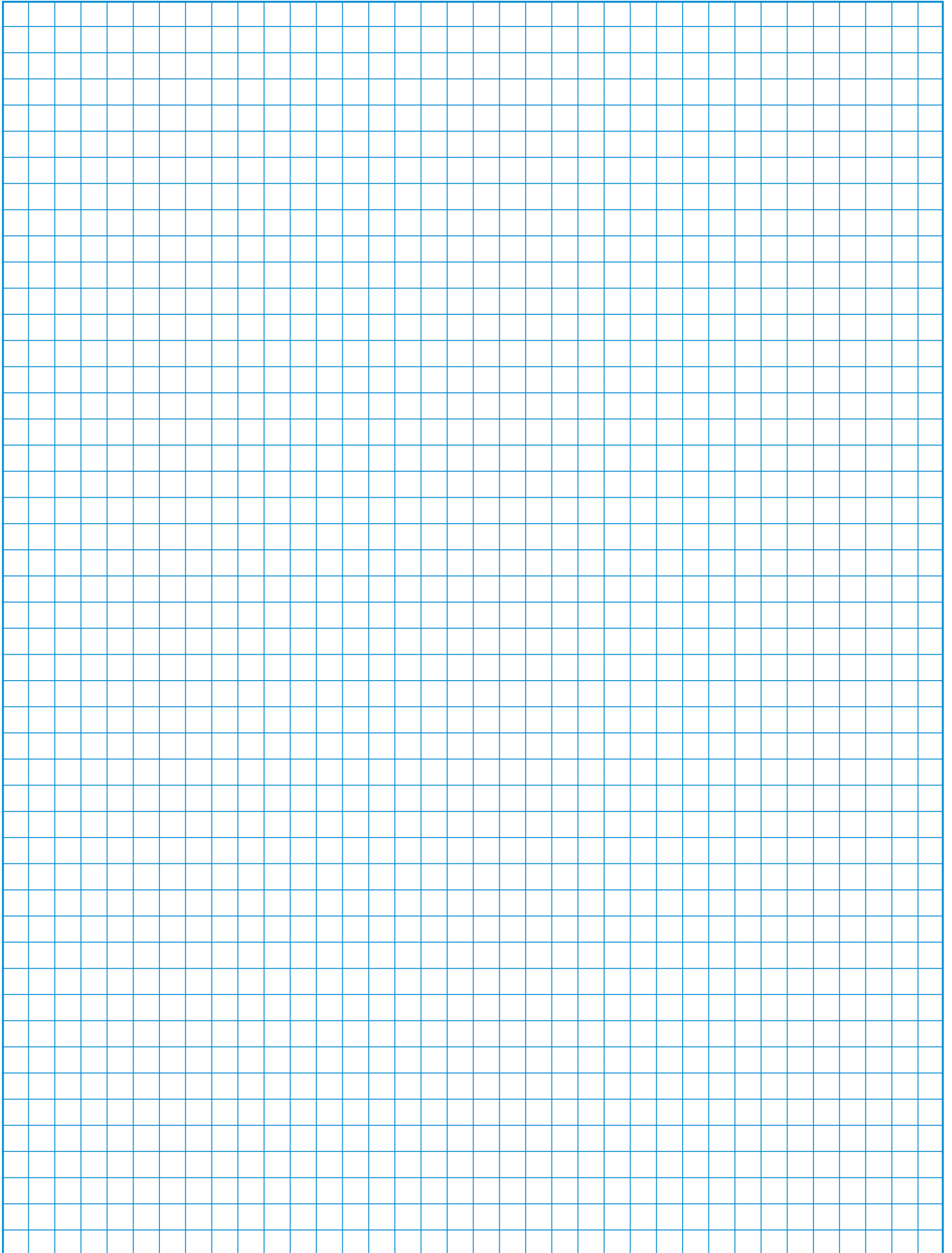

The Range of “Blue Line” Switchgear

Technical literature covering the following products is available on request.

| | Catalog Number |
|--|-------------------|
| Main Switches and Main Switches with Emergency Function 16 A-315 A Maintenance Switches 20 A-315 A Switch Disconnectors 20 A-315 A According to IEC 60947-3, EN 60947-3, VDE 0660 part 107, IEC 60204, EN 60204 and VDE 0113 | 500 |
| CL Switches 10 A-20 A C, CA and CAD Switches 10 A-315 A and L Switches 350 A-2400 A C, CA and CAD switches are designed for universal application. They are recommended for instrument, isolator, double-throw and motor control. L switches are designed for load and off-load applications. They are used to switch resistive or low inductive loads. | 100 |
| Optional Extras and Enclosures The complete product line, a large number of optional extras is available, including door interlocks, push-pull devices, cylinder and padlock attachments, control and indicator devices, AC motor drives, as well as enclosures, both insulated and metal. | 101 |
| A and AD Switches 6 A-25 A A and AD switches have 4 contacts in each switching stage. These switches provide an extensive range of switch functions and require a minimum mounting depth. Up to 36 switching positions are possible, with availability of 48 contacts per 12 stage switch column. | 110 |
| CG, CH and CHR Switches 10 A-25 A Ultra compact CG, CH and CHR switches are ideally suited for control and instrumentation applications. Switch terminals are “finger-proof” and conveniently accessible for wiring and are delivered open. All CG4 switches offer specially designed gold plated contacts or H-bridges with “cross-wire” contact systems, which facilitates their use in electronic circuitry and chemically aggressive environments. | 120 |
| DH, DHR, DK and DKR Switches 6 A-16 A DH, DHR, DK and DKR switches incorporate unique corrosion resistant contacts that permit operation on system voltage as low as 1 V. They have fully enclosed and protected contacts which can be operated either by rotary and/or lateral handle movement. D switches are used in calibration and semiconductor circuits. They are also used for relay and contactor control. | 130 |
| X Switches 80 A-630 A X switches can be applied for load, tap and gang switching duties. They incorporate 6 contacts in each switching stage. Their compact design provides a minimum length dimension for mounting purposes. | 140 |
| KG Switches 20 A-315 A KG switches are excellent circuit interruptors. They have high through fault and fault making capacities and are especially designed for use as isolators and safety switches for machine tools, distribution panels and switchboards. KG ON/OFF switches offer unusually high dimensioned air and creepage distances between terminals which are designed for time saving “straight-line” wiring. ON/OFF switches are available with up to 8 poles and double-throw switches are available with up to 4 poles. | 150 |
| Push Buttons and Pilot Lights, 22,5 mm Ø A complete range of state-of-the-art push buttons and pilot lights represent an ideal combination of functional security and economical efficiency in a modular design. | 302 |

Australia

Kraus & Naimer Pty. Ltd.
379 Liverpool Road, ASHFIELD, N.S.W. 2131
P: 1800 567 948
E: sales-au@krausnaimer.com

Austria

Kraus & Naimer GmbH
Schumannngasse 39
1180 WIEN
P: +43 1 404 06 0
E: sales-at@krausnaimer.com

Belgium, Luxembourg

Kraus & Naimer B.V.
Ikaros Business Park
Ikaroslaan 83
1930 ZAVENTHEM
P: +32 2 757 0141
F: +32 2 757 1640
E: sales-be@krausnaimer.com

Brazil

Central and South America
Kraus & Naimer Ind. Com. Ltda.
Rua Santa Monica, 1061
Parque Industrial San Jose
P: +55 11 2198 1288
F: +55 11 2198 1251
E: knbrasil@krausnaimer.com.br

Canada

Kraus & Naimer Ltd.
219 Connie Crescent, Unit 13A
CONCORD, Ontario, L4K 1L4
P: +1 905 738 1666
E: sales-ca@krausnaimer.com

Cyprus

ELECTROMATIC CONSTRUCTIONS LTD.
72, Evagoras Pallikarides Str., 2235 LATSIA-Nicosia
P. O. Box 12630, 2251 LATSIA-Nicosia
P: +357 2 48 41 41
F: +357 2 48 57 47
E: electromatic@cytanet.com.cy

Czech Republic

OBZOR, výrobní družstvo Zlín
Na Slanici 378
763 02 ZLÍN
P: +420 577 195 150
F: +420 577 195 152
E: odbyt@obzor.cz

Denmark

THIIM A/S
Transformervej 31
2860 SOEBORG
P: +45 4485 8000
F: +45 4485 8005
E: thiim@thiim.com

Finland

Kraus & Naimer Oy
Kiitoradankuja 8
01530 VANTAA
P: +358 9 825 424 0
E: sales-fi@krausnaimer.com

France

Kraus & Naimer s.a.s.
33, rue Bobillot
75013 PARIS
P: +33 1 58 40 80 80
E: sales-fr@krausnaimer.com

Germany

Kraus & Naimer GmbH
Wikingerstraße 20-28, 76189 KARLSRUHE
Postfach 10 01 24, 76231 KARLSRUHE
P: +49 721 59 88 0
E: sales-de@krausnaimer.com

Great Britain

Kraus & Naimer Ltd.
115 London Road
NEWBURY/BERKSHIRE RG14 2AH
P: +44 1635 262626
F: +44 1635 37807
E: sales-uk@krausnaimer.com

Greece

KALAMARAKIS-SAPOUNAS S. A.
Ionias & Neromilou Str., P. O. Box 46566
13671 ACHARNES/ATHENS
P: +30 2 10 240 6000 6
F: +30 2 10 240 6007
E: kalamarakis.sapounas@ksa.gr

Hungary

GANZ KK KFT.
X. Kőbányai út 41/c, Postfach 87
1475 BUDAPEST
P: +36 1 261 5479
E: ganzkk@ganzkk.hu

Iceland

JOHAN RÖNNING LTD.
Klettagarðar 25
104 REYKJAVIK
P: +354 5200 800
E: ronning@ronning.is

Republic of Ireland

Kraus & Naimer Ltd.
4235 Atlantic Avenue
Westpark Business Campus
Shannon, Co. Clare
P: +353 61 704700
F: +353 61 471084
E: sales-ie@krausnaimer.com

Italy

Kraus & Naimer s.r.l.
Via Terracini, 9
24047 TREVIGLIO (BG)
P: +39 0363 30 11 12
E: sales-it@krausnaimer.com

Japan

Kraus & Naimer Ltd.
Yoshiwada Building 2F
1-11-6 Hamamatsucho
Minato-Ku, TOKYO 105-0013
P: +81 3 3436 6151
F: +81 3 3436 6325
E: sales-jp@krausnaimer.com

Mexico

JC INGENIERÍA Y CONTROL, SA DE CV.
Ángel Gaviño 30,
C. Satélite, C. Medicos,
Naucalpan Edo. de Mexico, C.P. 53100
P: +52 55 55 62 75 77
F: +52 55 55 62 04 34
E: ventas@jcingenieriacontrol.com

Netherlands

Kraus & Naimer B.V.
Wegtersweg 38
7556 BR HENGELO
P: +31 74 291 9441
F: +31 74 291 98380
E: sales-nl@krausnaimer.com

New Zealand

Kraus & Naimer Ltd.
42 Miramar Avenue, WELLINGTON 6022
P. O. Box 15-009, WELLINGTON 6243
P: + 64 0800 736 522
E: sales-nz@krausnaimer.com

Norway

Kraus & Naimer AB Avd. Norge
c/o Tim Figved
Gurinstubben 27
0584 Olso
T: +47 22 64 44 20
E: sales-no@krausnaimer.com

Poland

ASTAT LOGISTYKA SP. Z O.O.
Dąbrowskiego 441
60451 POZNAŃ
P: +48 61 849 80 89
E: k.swiderski@astat.pl

Portugal

ELECTRICAL-DAMAS, FERREIRA & DAMASCENO, LDA.
Apartado 1063, S. Ant. Cavaleiros
2670 LOURES
P: +351 21 989 8939
F: +351 21 988 6464
E: electrical@electrical.pt

Singapore, India, Middle East – UAE

Kraus & Naimer Pte. Ltd.
988 Toa Payoh North
#05-01/02/07/08
SINGAPORE 319002
T: +65 6473 8166
E: sales-sg@krausnaimer.com

Slovenia

SCHRACK TECHNIK D.O.O.
Pameče 175
SI-2380 SLOVENJ GRADEC
P: +386 2 88 392 00
F: +386 2 88 434 71
E: d.goljat@schrack.si

Republic of South Africa

Kraus & Naimer Pty. Ltd.
7 Village Crescent, Linbro Village
Linbro Business Park, SANDTON 2065
P. O. Box 511, KELVIN 2054
P: +27 11 608 6060
E: sales-za@krausnaimer.com

Spain

Kraus & Naimer B.V.
P: +34 662 696 014
E: sales-es@krausnaimer.com

Sweden

Kraus & Naimer AB
Dr. Widerströms Gata 11, Hägersten
Box 42097, 126 14 STOCKHOLM
P: +46 8 97 00 80
E: sales-se@krausnaimer.com

Switzerland

AWAG Elektrotechnik AG
Sandbühlstraße 2
CH-8604 VOLKETSCHWIL
P: +41 44 908 19 19
E: info@awag.ch

Turkey

KARDES ELEKTRİK SANAYİ VE TİCARET A.Ş.
Yassıoren Mah. Hıfıa Sok. No: 4
34277 Arnavutköy-Istanbul-Turkey
P: +90 212 624 92 04 118
F: +90 212 592 48 10
E: info@unalkardes.com.tr

USA

Kraus & Naimer Inc.
760 New Brunswick Road
SOMERSET, NJ 08873
P: +1 732 560 1240
E: sales-us@krausnaimer.com



Kraus & Naimer



Contact us:

www.krausnaimer.com