

# GoTo Europe Focused Delivery Program

Product Overview Linear Motion Technology

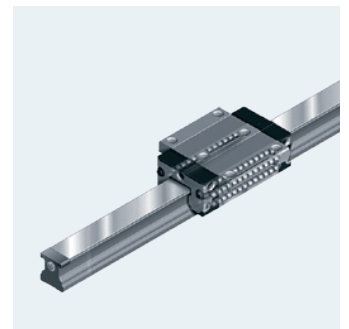

# The products I need when I need them

In today's global competition every day counts. Fast response times have become an important success factor for machine manufacturers. Reliable, on time delivery of machine components plays a critical role in this regard – especially when talking about individual and custom machine builders. With Rexroth's GoTo Focused Delivery Program you benefit from easy ordering processes and on-time delivery of our high-demand products across our broad range of technologies.

You receive the most common Rexroth products from Hydraulics and Electric Control Technology, as well as Linear Motion and Assembly Technologies delivered reliably and on time. And that across Europe, taking into account product-dependent maximum order quantities and with unrivaled simplicity. Construct your machines and systems quickly and efficiently – we support you during the process.

## Your advantages

- ▶ Reduced inventories and capital commitment through short, reliable delivery times
- ▶ Flexible response to customer and market demands through high availability of many products
- ▶ Simple, fast ordering via e-mail, fax, mail or eCommerce at Bosch Rexroth or its sales partners



# The GoTo product overviews according to technologies

## GoTo product overviews



### ► Industrial and Mobile Hydraulics



### ► Electric Drives and Controls, Tightening Technology



### ► Linear Motion Technology



### ► Assembly Technology



The GoTo Focused Delivery Program offers a targeted selection of our high-demand products with preferred service: As a result, you receive your products quickly and reliably, allowing you to respond to your market and customer requirements at any time.

You benefit from simplified access to product information, preferred order processing and reduced delivery times. This allows you to complete your machine or system on schedule.

Our GoTo product overviews, whether in printed form or on the Internet, show you the complete portfolio. In addition, our webpages quickly provide you with additional information on the respective product, on the technical data as well as on ordering.



# Your product in just three steps



## 1. Select product



## 2. View product data



- ▶ Product-specific information
- ▶ Maximum order quantities
- ▶ Availability
- ▶ Delivery times
- ▶ Prices

## 1. Select product

Use the GoTo product overviews to find the desired products.

## 2. View product data

Now visit the focused delivery program website – [www.boschrexroth.com/goto](http://www.boschrexroth.com/goto). It offers simple access to additional product information, including data sheets, part numbers, specifications, downloads and more.

## 3. Order product

To order, contact Rexroth, your sales partner, or simply order online via our eShop: [www.boschrexroth.com/eshop](http://www.boschrexroth.com/eshop)

## 3. Order product





# Content

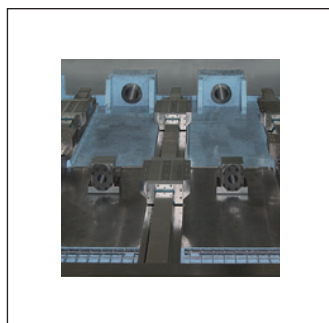

---

<b>Roller Rail Systems</b>	<b>7</b>
Roller Runner Blocks	8
Roller Guide Rails	12





---

<b>Ball Rail Systems</b>	<b>15</b>
Ball Runner Blocks	16
Ball Guide Rails	28

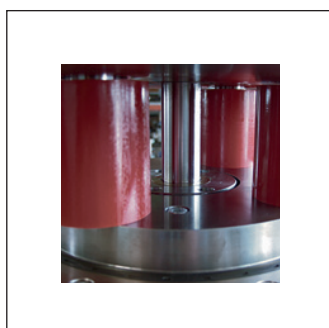

---

<b>Miniature Ball Rail Systems</b>	<b>39</b>
Miniature Ball Runner Blocks	40
Miniature Ball Guide Rails	42



---

<b>Linear Bushings and Shafts</b>	<b>47</b>
Linear Bushings and Linear-Sets	48
Precision Steel Shafts	69
Shaft Support Blocks	71

# Content

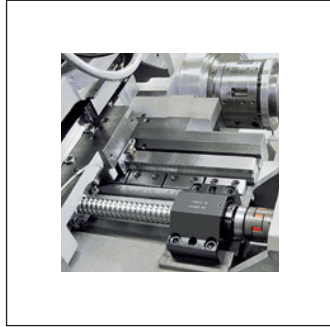

---

<b>Ball Screw Assemblies</b>	<b>73</b>
Ball Nuts	74
Precision Screws	77

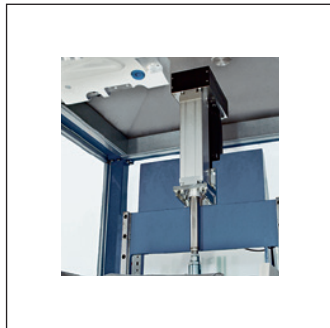

---

<b>Linear Systems</b>	<b>79</b>
Electromechanical Cylinders	80

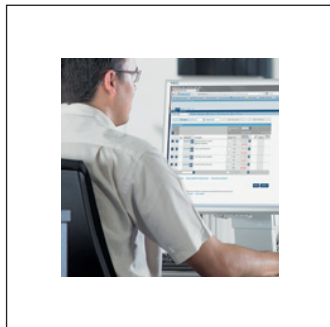

---

<b>Ordering Information</b>	<b>83</b>
-----------------------------	-----------

# Roller Rail Systems

Roller Rail Systems from Rexroth are designed to meet the highest expectations on precision and rigidity in linear motion. The range offers compact, linear motion guides in various accuracy classes, with rollers as the rolling elements. The runner blocks and guide rails feature extremely high load capacity and rigidity for especially demanding conditions of use. The advantages of the rolling-element design are particularly apparent when it comes to energy efficiency. Here, they can improve the degree of efficiency by up to 90% relative to sliding guides. This reduces the required energy input and therefore has a direct impact on energy costs.

Further positive factors include exceptional precision and travel accuracy, regardless of the travel speed and load.

## Roller Runner Blocks

Rexroth roller runner blocks have top rigidity in all load directions for best precision and high travel accuracy.

## Roller Guide Rails

Precision ground reference edges on both sides of the roller guide rails facilitate installation. The cover strip made of corrosion-resistant spring steel as per EN 10088 provides one single cover for all guide rail mounting holes. It is easy to use, secure, and a great time-saver compared to individual mounting hole plugs.

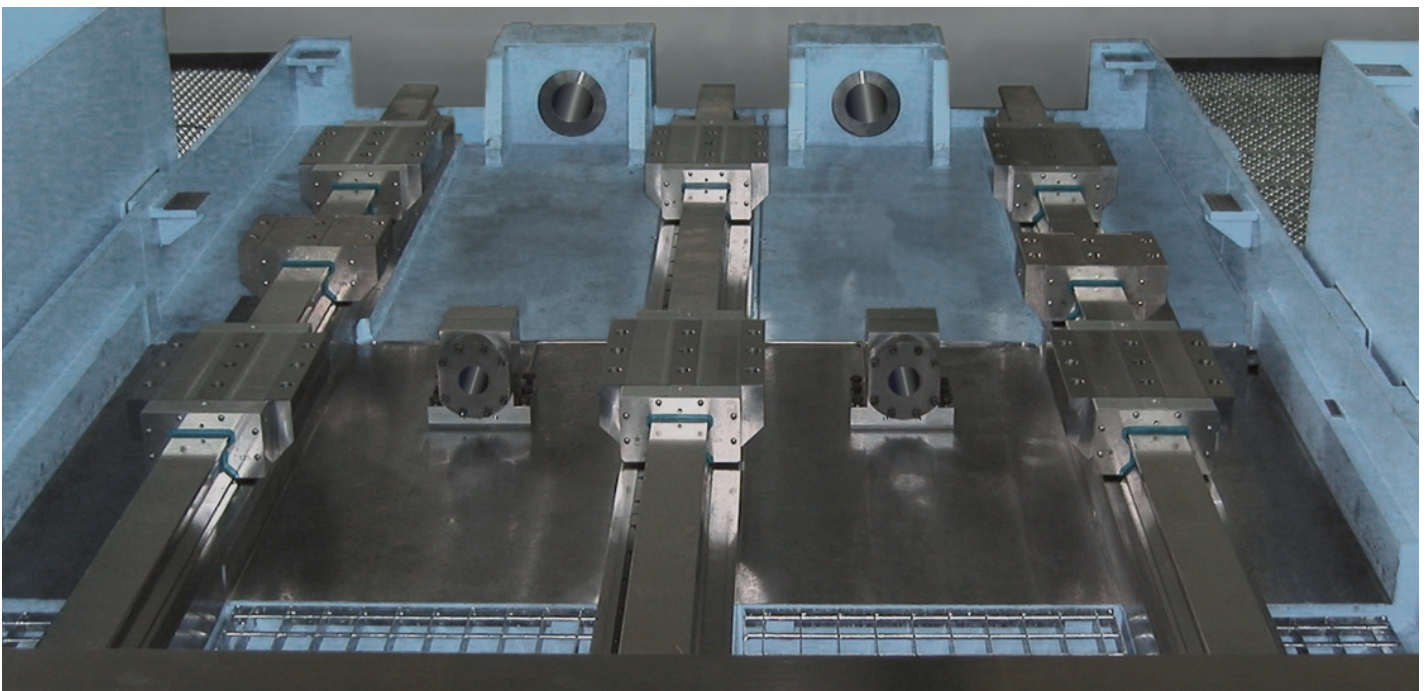



# Standard Roller Runner Blocks, steel, FNS, Type R1851

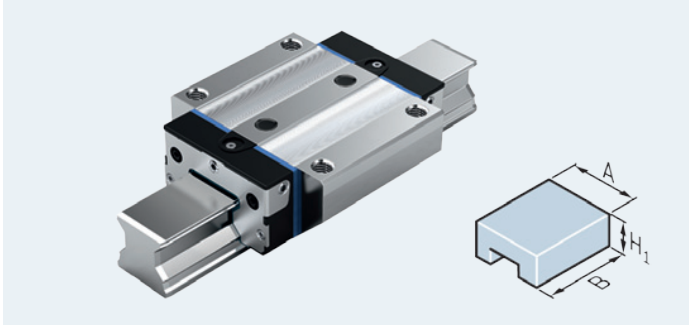

- ▶ For mounting from above and below
- ▶ High load-bearing capacity
- ▶ High rigidity
- ▶ Enhanced travel accuracy in RSHP version
- ▶ High travel speed up to 4 m/s

## Features

- ▶ Unrestricted interchangeability
- ▶ Minimal friction losses
- ▶ Integrated all-around sealing as standard
- ▶ High torque load capability

## Product description

Roller runner blocks are characterized by their exceptional rigidity and extremely high load-bearing capacity. Further design types and sizes can be found in the “Roller Rail Systems” catalog. In the high-precision version RSHP the travel accuracy has been substantially increased once again through the optimized roller entry-zone geometry, particularly in the recirculation zone. Sizes 35 and 45 in version RSHP.

### Detailed information:

Roller Rail Systems R310EN 2302 catalog  
Roller Rail Systems RSHP R999000354 catalog

## Technical data

Size		25 <sup>1)</sup>	35 RSHP	45 RSHP
C	N	26 900	61 000	106 600
$M_t$	Nm	348	1 210	2 640
$M_L$	Nm	260	760	1 650
$v_{max}$	m/s	3	4	4
$a_{max}$	$m/s^2$	150	150	150
A	mm	70	100	120
$B_3$	mm	97	118	147
$H_1$	mm	30	41	51
m	kg	0.8	2.15	4.05

<sup>1)</sup> Version RSHP in preparation.

For ordering information for the GoTo products, see page 84.

# Standard Roller Runner Blocks, steel, FLS, Type R1853

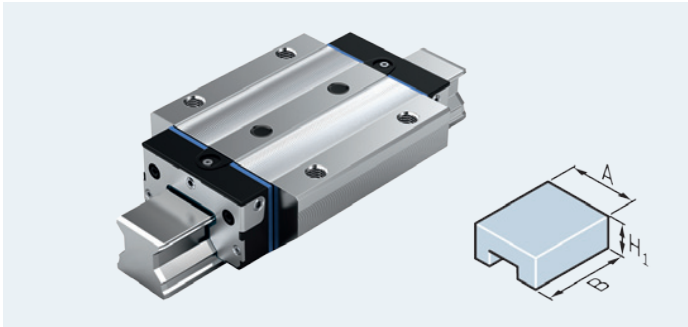

- ▶ For mounting from above and below
- ▶ High load-bearing capacity
- ▶ High rigidity
- ▶ Enhanced travel accuracy in RSHP version
- ▶ High travel speed up to 4 m/s

## Features

- ▶ Unrestricted interchangeability
- ▶ Minimal friction losses
- ▶ Integrated all-around sealing as standard
- ▶ High torque load capability
- ▶ Long version for even higher load capacity and rigidity

## Product description

Roller runner blocks are characterized by their exceptional rigidity and extremely high load-bearing capacity. Further design types and sizes can be found in the “Roller Rail Systems” catalog. In the high-precision version RSHP the travel accuracy has been substantially increased once again through the optimized roller entry-zone geometry, particularly in the recirculation zone. Sizes 35 and 45 in version RSHP.

### Detailed information:

Roller Rail Systems R310EN 2302 catalog  
Roller Rail Systems RSHP R999000354 catalog

## Technical data

Size		25 <sup>1)</sup>	35 RSHP	45 RSHP
C	N	33 300	74 900	132 300
M <sub>t</sub>	Nm	432	1 490	3 270
M <sub>L</sub>	Nm	420	1 220	2 690
v <sub>max</sub>	m/s	3	4	4
a <sub>max</sub>	m/s <sup>2</sup>	150	150	150
A	mm	70	100	120
B <sub>3</sub>	mm	115	142.00	179.50
H <sub>1</sub>	mm	30	41	51
m	kg	1.1	2.70	5.15

<sup>1)</sup> Version RSHP in preparation.

## Standard Roller Runner Blocks, steel, SNH, Type R1821

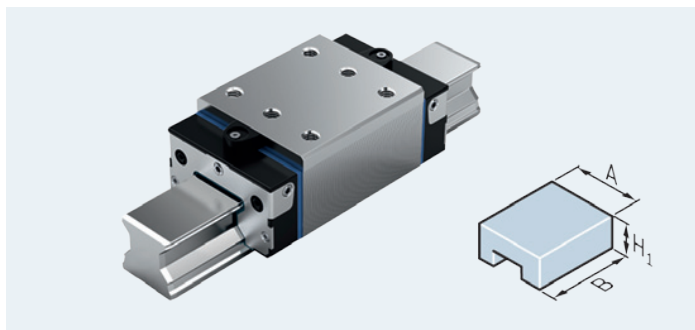

- ▶ For mounting from above
- ▶ High load-bearing capacity
- ▶ High rigidity
- ▶ Enhanced travel accuracy in RSHP version
- ▶ High travel speed up to 4 m/s

### Features

- ▶ Unrestricted interchangeability
- ▶ Minimal friction losses
- ▶ Integrated all-around sealing as standard
- ▶ High torque load capability

### Product description

Roller runner blocks are characterized by their exceptional rigidity and extremely high load-bearing capacity. Further design types and sizes can be found in the “Roller Rail Systems” catalog. In the high-precision version RSHP the travel accuracy has been substantially increased once again through the optimized roller entry-zone geometry, particularly in the recirculation zone. Sizes 35 and 45 in version RSHP.

### Detailed information:

Roller Rail Systems R310EN 2302 catalog  
Roller Rail Systems RSHP R999000354 catalog

### Technical data

Size		25 <sup>1)</sup>	35 RSHP	45 RSHP
C	N	26 900	61 000	106 600
$M_t$	Nm	348	1 210	2 640
$M_L$	Nm	260	760	1 650
$v_{max}$	m/s	3	4	4
$a_{max}$	$m/s^2$	150	150	150
A	mm	48	70	86
$B_3$	mm	97	118	147
$H_1$	mm	34	48	61
m	kg	0.6	1.85	3.35

<sup>1)</sup> Version RSHP in preparation.

For ordering information for the GoTo products, see page 84.



# Standard Roller Runner Blocks, steel, SLH, Type R1824

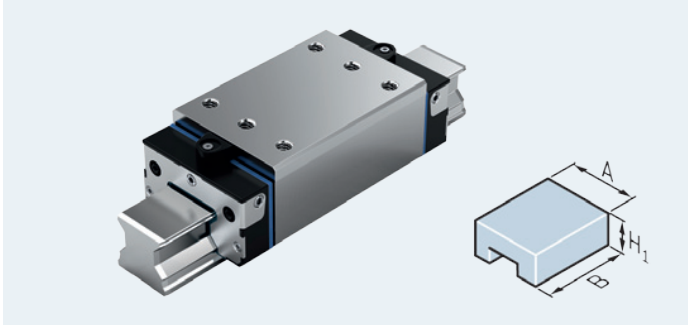

- ▶ For mounting from above
- ▶ High load-bearing capacity
- ▶ High rigidity
- ▶ Enhanced travel accuracy in RSHP version
- ▶ High travel speed up to 4 m/s

## Features

- ▶ Unrestricted interchangeability
- ▶ Minimal friction losses
- ▶ Integrated all-around sealing as standard
- ▶ High torque load capability
- ▶ Long version for even higher load capacity and rigidity

## Product description

Roller runner blocks are characterized by their exceptional rigidity and extremely high load-bearing capacity. Further design types and sizes can be found in the “Roller Rail Systems” catalog. In the high-precision version RSHP the travel accuracy has been substantially increased once again through the optimized roller entry-zone geometry, particularly in the recirculation zone. Sizes 35 and 45 in version RSHP.

### Detailed information:

Roller Rail Systems R310EN 2302 catalog  
Roller Rail Systems RSHP R999000354 catalog

## Technical data

Size		25 <sup>1)</sup>	35 RSHP	45 RSHP
C	N	33 300	74 900	132 300
$M_t$	Nm	432	1 490	3 270
$M_L$	Nm	420	1 220	2 690
$v_{max}$	m/s	3	4	4
$a_{max}$	m/s <sup>2</sup>	150	150	150
A	mm	48	70	86
$B_3$	mm	115	142	179
$H_1$	mm	34	48	61
m	kg	0.9	2.35	4.45

<sup>1)</sup> Version RSHP in preparation.

## Standard Roller Guide Rails, steel, SNS, Type R1805, with cover strip and protective end caps

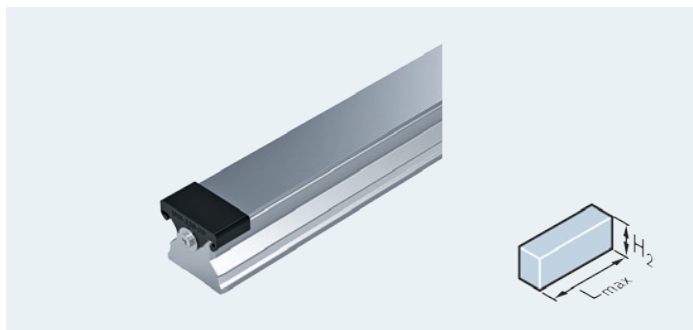

- ▶ For mounting from above
- ▶ Accuracy class P
- ▶ With cover strip made of corrosion-resistant spring steel per EN 10088

### Features

- ▶ One-piece version
- ▶ Screw-down plastic protective end caps

### Product description

The highly accurate precision-ground roller guide rails have reference edges on both sides. The optimally shaped chamfers around the edges of the end faces make it easier to push on the runner blocks and protect the seals from being damaged during this process.

Further design types and sizes can be found in the “Roller Rail Systems” catalog.

### Detailed information:

Roller Rail Systems R310EN 2302 catalog

### Technical data

Size		25	35	45
$L_{max}$	mm	3 986	3 996	3 986
$H_2$	mm	23.6	31.1	39.1
m	kg/m	3.1	6.3	10.3

For ordering information for the GoTo products, see page 84.

## Standard Roller Guide Rails, steel, SNS, Type R1807, for mounting from below

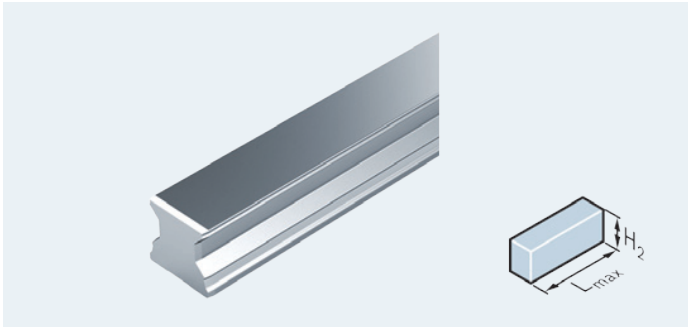

- ▶ For mounting from below
- ▶ Accuracy class P

### Features

- ▶ One-piece version

### Product description

The highly accurate precision-ground roller guide rails have reference edges on both sides. The optimally shaped chamfers around the edges of the end faces make it easier to push on the runner blocks and protect the seals from being damaged during this process.

Further design types and sizes can be found in the “Roller Rail Systems” catalog.

### Detailed information:

Roller Rail Systems R310EN 2302 catalog

### Technical data

Size		25	35	45
$L_{\max}$	mm	3 986	3 996	3 986
$H_2$	mm	23.4	30.8	38.8
m	kg/m	3.1	6.3	10.3

For ordering information for the GoTo products, see page 84.





# Ball Rail Systems

Rexroth Ball Rail Systems offer outstanding characteristics and are designed primarily for use in general machine construction and machine tools. Especially notable are their high performance and long life. The high-quality long-term lubrication concept and minimal-quantity lubrication systems combined with the wear-resistance typical of rolling-element guides assure a high level of operational reliability and consistent precision throughout the service life of these components. A unique feature of these systems is their unrestricted interchangeability. The ball guide rails and ball runner blocks are manufactured with such high precision that each individual component element within one accuracy class can be replaced by another at any time.

## Ball Runner Blocks

Ball runner blocks are available in many different sizes, design styles and versions, also including self-aligning models.

## Ball Guide Rails

Precision ground reference edges on both sides of the ball guide rails facilitate installation. The cover strip made of corrosion-resistant spring steel as per EN 10088 provides one single easy-to-use and secure cover for all guide rail mounting holes.

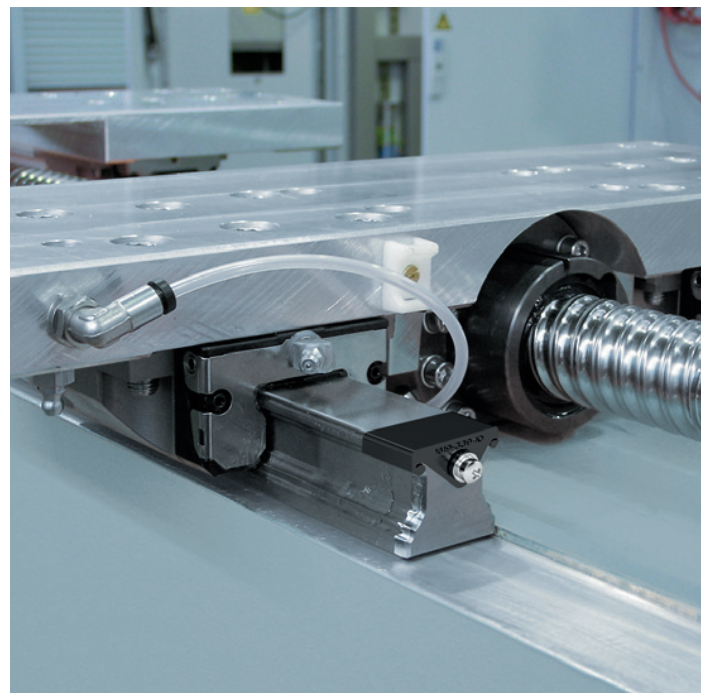
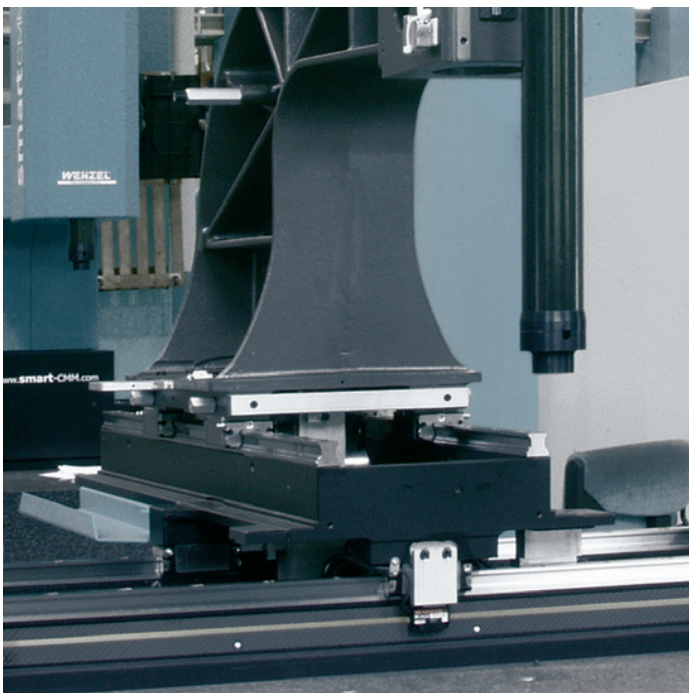

# Standard Ball Runner Blocks, steel, FNS, Type R1651

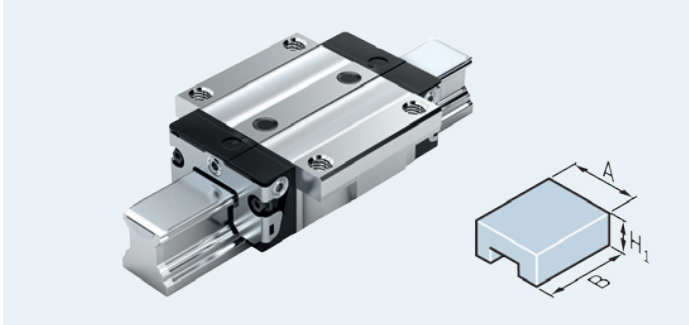

- ▶ High load-bearing capacity
- ▶ High rigidity
- ▶ For mounting from above and below
- ▶ Travel speed:  $v_{\max} = 5 \text{ m/s}$
- ▶ Acceleration:  $a_{\max} = 500 \text{ m/s}^2$

## Features

- ▶ Now with improved performance data
- ▶ Unrestricted interchangeability
- ▶ Integrated all-around sealing as standard
- ▶ Same load capacity in all four directions of loading
- ▶ Can be used on all Ball Guide Rails SNS

## Product description

High rigidity in all load directions – permits applications with just one runner block per rail. Unrestricted interchangeability means that all Rexroth ball runner blocks and ball guide rails within one accuracy class can be combined at will. Rexroth ball runner blocks can optionally be equipped with a ball chain to optimize noise levels.

### Detailed information:

Ball Rail Systems R310EN 2202 catalog

## Technical data

Size		15	20	25	30	35	45
C without ball chain	N	9 860	23 400	28 600	36 500	51 800	86 400
C with ball chain	N	8 850	22 200	26 700	34 800	49 400	82 400
$M_t$ without ball chain	Nm	95	300	410	630	1 110	2 330
$M_t$ with ball chain	Nm	85	280	380	600	1 060	2 220
$M_L$ without ball chain	Nm	68	200	290	440	720	1 540
$M_L$ with ball chain	Nm	62	190	270	420	700	1 480
A	mm	47	63	70	90	100	120
B	mm	58.2	75	86.2	97.7	110.5	137.6
$H_1$	mm	19.9	25.35	29.9	35.35	40.4	50.3
m	kg	0.2	0.45	0.65	1.1	1.6	3.0

For ordering information for the GoTo products, see page 85.

# Standard Ball Runner Blocks, steel, FLS, Type R1653

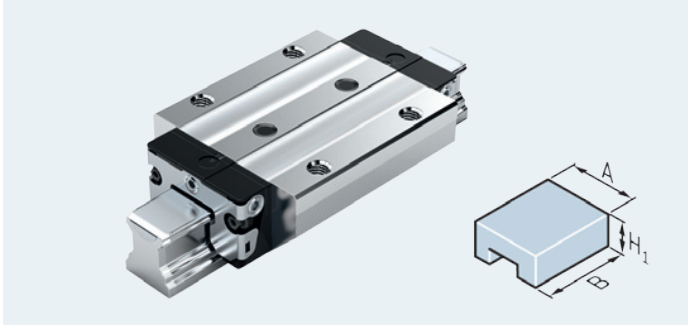

- ▶ Long version for even higher load capacity and rigidity
- ▶ For mounting from above and below
- ▶ Travel speed:  $v_{\max} = 5 \text{ m/s}$
- ▶ Acceleration:  $a_{\max} = 500 \text{ m/s}^2$

## Features

- ▶ Now with improved performance data
- ▶ Unrestricted interchangeability
- ▶ Integrated all-around sealing as standard
- ▶ Same load capacity in all four directions of loading
- ▶ Can be used on all Ball Guide Rails SNS

## Product description

High rigidity in all load directions – permits applications with just one runner block per rail. Unrestricted interchangeability means that all Rexroth ball runner blocks and ball guide rails within one accuracy class can be combined at will.

### Detailed information:

Ball Rail Systems R310EN 2202 catalog

## Technical data

Size		15	20	25	30	35	45
$C^{1)}$	N	12 800	29 600	37 300	46 000	66 700	111 000
$M_t^{1)}$	Nm	120	380	530	800	1 440	3 010
$M_L^{1)}$	Nm	120	340	530	740	1 290	2 730
A	mm	47	63	70	90	100	120
B	mm	72.6	91.0	107.9	119.7	139.0	174.1
$H_1$	mm	19.90	35.35	29.90	35.35	40.40	50.30
m	kg	0.30	0.55	0.90	1.50	2.25	4.30

<sup>1)</sup> The load capacities (N) and moments (Nm) apply to Ball Runner Blocks without ball chain.

For ordering information for the GoTo products, see page 85.

R310EN 2060, 2014-05, Bosch Rexroth AG

## Standard Ball Runner Blocks, steel, FKS, Type R1665

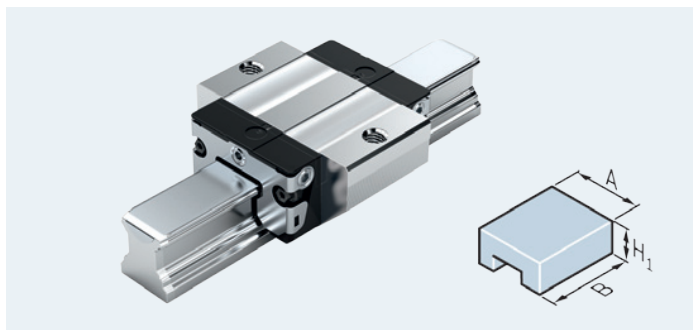

- ▶ For restricted space in the longitudinal direction
- ▶ For mounting from above and below
- ▶ Medium load-bearing capacity
- ▶ Travel speed:  $v_{\max} = 5 \text{ m/s}$
- ▶ Acceleration:  $a_{\max} = 500 \text{ m/s}^2$

### Features

- ▶ Now with improved performance data
- ▶ Unrestricted interchangeability
- ▶ Integrated all-around sealing as standard
- ▶ Same load capacity in all four directions of loading
- ▶ Can be used on all Ball Guide Rails SNS

### Product description

Optimal rigidity for standard applications. Short version of the standard runner block.

### Detailed information:

Ball Rail Systems R310EN 2202 catalog

### Technical data

Size		15	20	25	30	35
$C^{1)}$	N	6 720	15 400	19 800	25 600	36 600
$M_t^{1)}$	Nm	65	200	280	440	790
$M_L^{1)}$	Nm	29	83	130	200	340
A	mm	47	63	70	90	100
B	mm	44.7	57.3	67	75.3	84.9
$H_1$	mm	19.9	25.35	29.9	35.35	40.4
m	kg	0.15	0.3	0.5	0.8	1.2

<sup>1)</sup> The load capacities (N) and moments (Nm) apply to Ball Runner Blocks without ball chain.

For ordering information for the GoTo products, see page 86.



# Standard Ball Runner Blocks, steel, SNS, Type R1622

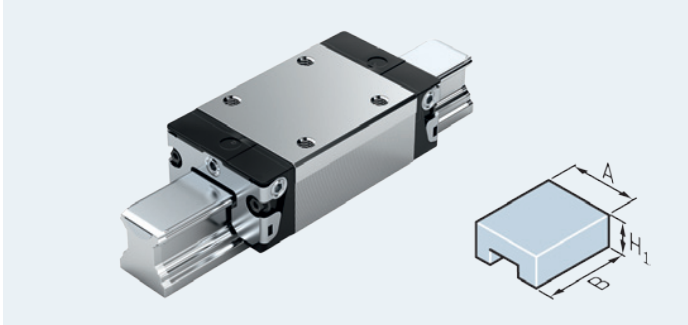

- ▶ High load-bearing capacity
- ▶ For restricted space in the transverse direction
- ▶ For mounting from above
- ▶ Travel speed:  $v_{\max} = 5 \text{ m/s}$
- ▶ Acceleration:  $a_{\max} = 500 \text{ m/s}^2$

## Features

- ▶ Now with improved performance data
- ▶ Unrestricted interchangeability
- ▶ Integrated all-around sealing as standard
- ▶ Same load capacity in all four directions of loading
- ▶ Can be used on all Ball Guide Rails SNS

## Product description

High rigidity in all load directions – permits applications with just one runner block per rail. Unrestricted interchangeability means that all Rexroth ball runner blocks and ball guide rails within one accuracy class can be combined at will. Rexroth ball runner blocks can optionally be equipped with a ball chain to optimize noise levels.

### Detailed information:

Ball Rail Systems R310EN 2202 catalog

## Technical data

Size		15	20	25	30	35	45
C without ball chain	N	9 860	23 400	28 600	36 500	51 800	86 400
C with ball chain	N	8 850	22 200	26 700	34 800	49 400	82 400
$M_t$ without ball chain	Nm	95	300	410	630	1 110	2 330
$M_t$ with ball chain	Nm	85	280	380	600	1 060	2 220
$M_L$ without ball chain	Nm	68	200	290	440	720	1 540
$M_L$ with ball chain	Nm	62	190	270	420	700	1 480
A	mm	34	44	48	60	70	86
B	mm	58.2	75.0	86.2	97.7	110.5	137.6
$H_1$	mm	19.9	25.35	29.9	35.35	40.4	50.3
m	kg	0.15	0.35	0.5	0.85	1.25	2.4

For ordering information for the GoTo products, see page 87.

## Standard Ball Runner Blocks, steel, SLS, Type R1623

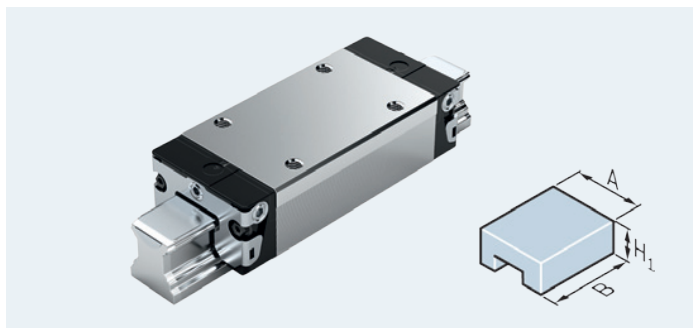

- ▶ Long version for even higher load capacity and rigidity
- ▶ For mounting from above
- ▶ Travel speed:  $v_{\max} = 5 \text{ m/s}$
- ▶ Acceleration:  $a_{\max} = 500 \text{ m/s}^2$

### Features

- ▶ Now with improved performance data
- ▶ Unrestricted interchangeability
- ▶ Integrated all-around sealing as standard
- ▶ Same load capacity in all four directions of loading
- ▶ Can be used on all Ball Guide Rails SNS

### Product description

High rigidity in all load directions – permits applications with just one runner block per rail. Unrestricted interchangeability means that all Rexroth ball runner blocks and ball guide rails within one accuracy class can be combined at will.

### Detailed information:

Ball Rail Systems R310EN 2202 catalog

### Technical data

Size		15	20	25	30	35	45
C <sup>1)</sup>	N	12 800	29 600	37 300	46 000	66 700	111 000
M <sub>t</sub> <sup>1)</sup>	Nm	120	380	530	800	1 440	3 010
M <sub>l</sub> <sup>1)</sup>	Nm	120	340	530	740	1 290	2 730
A	mm	34	44	48	60	70	86
B	mm	72.6	91.0	107.9	119.7	139.0	174.1
H <sub>1</sub>	mm	19.9	25.35	29.9	35.35	40.4	50.3
m	kg	0.2	0.45	0.65	1.1	1.7	3.2

<sup>1)</sup> The load capacities (N) and moments (Nm) apply to Ball Runner Blocks without ball chain.

For ordering information for the GoTo products, see page 87.

# Standard Ball Runner Blocks, steel, SKS, Type R1666

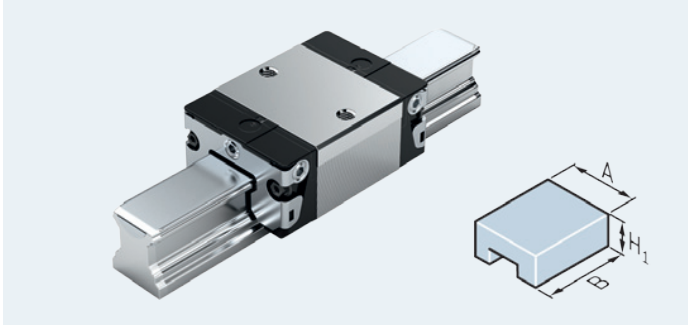

- ▶ For restricted space in the longitudinal and transverse direction
- ▶ For mounting from above
- ▶ Travel speed:  $v_{\max} = 5 \text{ m/s}$
- ▶ Acceleration:  $a_{\max} = 500 \text{ m/s}^2$
- ▶ Medium load-bearing capacity

## Features

- ▶ Now with improved performance data
- ▶ Unrestricted interchangeability
- ▶ Integrated all-around sealing as standard
- ▶ Same load capacity in all four directions of loading
- ▶ Can be used on all Ball Guide Rails SNS

## Product description

Optimal rigidity for standard applications. Short version of the standard runner block.

### Detailed information:

Ball Rail Systems R310EN 2202 catalog

## Technische Daten

Größe		15	20	25	30	35
$C^{1)}$	N	6 720	15 400	19 800	25 600	36 600
$M_t^{1)}$	Nm	65	200	280	440	790
$M_L^{1)}$	Nm	29	83	130	200	340
A	mm	34	44	48	60	70
B	mm	44.7	57.3	67	75.3	84.9
$H_1$	mm	19.9	25.35	29.9	35.35	40.4
m	kg	0.1	0.25	0.35	0.6	0.9

<sup>1)</sup> The load capacities (N) and moments (Nm) apply to Ball Runner Blocks without ball chain.

# Standard Ball Runner Blocks, steel, SNH, Type R1621

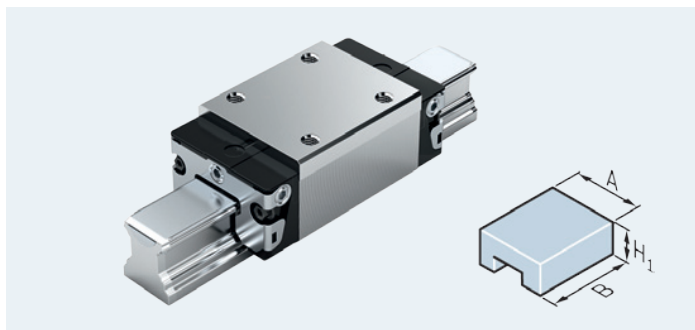

- ▶ High load-bearing capacity
- ▶ High rigidity
- ▶ For restricted space in the transverse direction
- ▶ Travel speed:  $v_{\max} = 5 \text{ m/s}$
- ▶ Acceleration:  $a_{\max} = 500 \text{ m/s}^2$

## Features

- ▶ Now with improved performance data
- ▶ Unrestricted interchangeability
- ▶ Integrated all-around sealing as standard
- ▶ Same load capacity in all four directions of loading
- ▶ Can be used on all Ball Guide Rails SNS

## Product description

High rigidity in all load directions – permits applications with just one runner block per rail. Unrestricted interchangeability means that all Rexroth ball runner blocks and ball guide rails within one accuracy class can be combined at will.

### Detailed information:

Ball Rail Systems R310EN 2202 catalog

## Technical data

Size		15	25	30	35	45
C <sup>1)</sup>	N	9 860	28 600	36 500	51 800	86 400
M <sub>t</sub> <sup>1)</sup>	Nm	95	410	630	1 110	2 330
M <sub>L</sub> <sup>1)</sup>	Nm	68	290	440	720	1 540
A	mm	34	48	60	70	86
B	mm	58.2	86.2	97.7	110.5	137.6
H <sub>1</sub>	mm	23.9	33.9	38.35	47.4	60.3
m	kg	0.2	0.6	0.95	1.55	3

<sup>1)</sup> The load capacities (N) and moments (Nm) apply to Ball Runner Blocks without ball chain.

For ordering information for the GoTo products, see page 89.

## Standard Ball Runner Blocks, steel, SLH, Type R1624

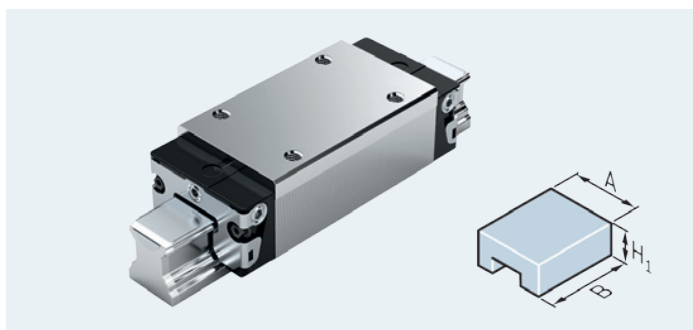

- ▶ Long version for even higher load capacity and rigidity
- ▶ For restricted space in the transverse direction
- ▶ Travel speed:  $v_{\max} = 5 \text{ m/s}$
- ▶ Acceleration:  $a_{\max} = 500 \text{ m/s}^2$

### Features

- ▶ Now with improved performance data
- ▶ Unrestricted interchangeability
- ▶ Integrated all-around sealing as standard
- ▶ Same load capacity in all four directions of loading
- ▶ Can be used on all Ball Guide Rails SNS

### Product description

High rigidity in all load directions – permits applications with just one runner block per rail. Unrestricted interchangeability means that all Rexroth ball runner blocks and ball guide rails within one accuracy class can be combined at will.

### Detailed information:

Ball Rail Systems R310EN 2202 catalog

### Technical data

Size		25	30	35	45
$C^{1)}$	N	37 300	46 000	66 700	111 000
$M_t^{1)}$	Nm	530	800	1 440	3 010
$M_L^{1)}$	Nm	530	740	1 290	2 730
A	mm	48	60	70	86
B	mm	107.9	119.7	139	174.1
$H_1$	mm	33.9	38.35	47.4	60.3
m	kg	0.8	1.2	2.1	4.1

<sup>1)</sup> The load capacities (N) and moments (Nm) apply to Ball Runner Blocks without ball chain.



# Super Ball Runner Blocks, steel, FKS, Type R1661

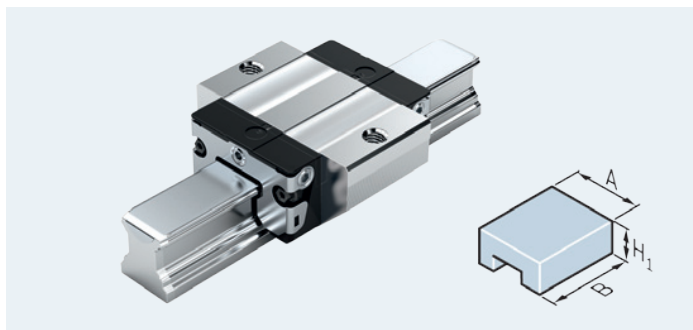

- ▶ Self-aligning
- ▶ Extra-compact design
- ▶ Travel speed:  $v_{\max} = 5 \text{ m/s}$
- ▶ Acceleration:  $a_{\max} = 500 \text{ m/s}^2$
- ▶ Low noise

## Features

- ▶ Unrestricted interchangeability
- ▶ Excellent dynamic characteristics
- ▶ Integrated all-around sealing as standard
- ▶ Same load capacity in all four directions of loading
- ▶ Can be used on all Ball Guide Rails SNS

## Product description

At least two ball runner blocks required per rail. The self-aligning feature assures, even in less accurately aligned configurations, that the balls enter the load-bearing zone smoothly and that the load is distributed evenly across the entire row of balls.

The result is extra-smooth running and considerably longer service life.

### Detailed information:

Ball Rail Systems R310EN 2202 catalog

## Technical data

Size		15	20	25	30	35
C <sup>1)</sup>	N	3 900	10 100	11 400	15 800	21 100
F <sub>max</sub> <sup>1)</sup>	N	1 500	3 900	4 400	6 100	8 100
M <sub>t</sub> <sup>1)</sup>	Nm	39	130	170	270	450
M <sub>t max</sub> <sup>1)</sup>	Nm	15	50	65	105	175
A	mm	47	63	70	90	100
B	mm	25.7	31.9	38.6	45	51.4
H <sub>1</sub>	mm	19.9	25.35	29.9	35.35	40.4
m	kg	0.15	0.3	0.5	0.8	1.2

<sup>1)</sup> The load capacities (N) and moments (Nm) apply to Ball Runner Blocks without ball chain.

For ordering information for the GoTo products, see page 90.

## Super Ball Runner Blocks, steel, SKS, Type R1662

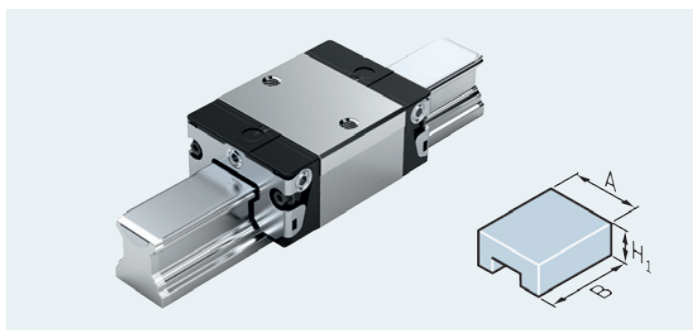

- ▶ Self-aligning
- ▶ Extra-compact design
- ▶ Travel speed:  $v_{\max} = 5 \text{ m/s}$
- ▶ Acceleration:  $a_{\max} = 500 \text{ m/s}^2$
- ▶ Low noise

### Features

- ▶ Unrestricted interchangeability
- ▶ Excellent dynamic characteristics
- ▶ Integrated all-around sealing as standard
- ▶ Same load capacity in all four directions of loading
- ▶ Can be used on all Ball Guide Rails SNS

### Product description

At least two ball runner blocks required per rail. The self-aligning feature assures, even in less accurately aligned configurations, that the balls enter the load-bearing zone smoothly and that the load is distributed evenly across the entire row of balls.

The result is extra-smooth running and considerably longer service life.

### Detailed information:

Ball Rail Systems R310EN 2202 catalog

### Technical data

Size		15	20	25	30	35
$C^{1)}$	N	3 900	10 100	11 400	15 800	21 100
$F_{\max}^{1)}$	N	1 500	3 900	4 400	6 100	8 100
$M_t^{1)}$	Nm	39	130	170	270	450
$M_{t \max}^{1)}$	Nm	15	50	65	105	175
A	mm	34	44	48	60	70
B	mm	25.7	31.9	38.6	45	51.4
$H_1$	mm	19.9	25.35	29.9	35.35	40.4
m	kg	0.1	0.25	0.35	0.6	0.9

<sup>1)</sup> The load capacities (N) and moments (Nm) apply to Ball Runner Blocks without ball chain.

# Standard Ball Runner Blocks, aluminum, FNS, Type R1631

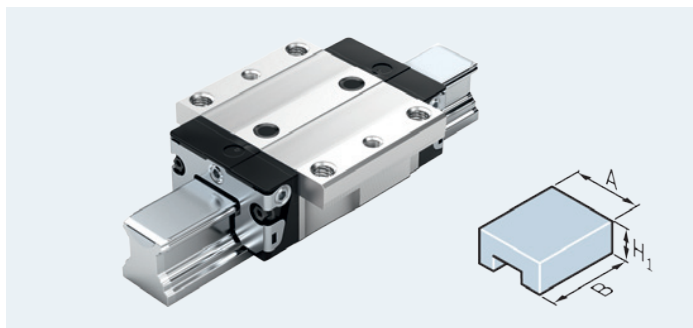

- ▶ High load-bearing capacity
- ▶ High torque load capacity
- ▶ For mounting from above and below
- ▶ Travel speed:  $v_{\max} = 5 \text{ m/s}$
- ▶ Acceleration:  $a_{\max} = 500 \text{ m/s}^2$

## Features

- ▶ Now with improved performance data
- ▶ Unrestricted interchangeability
- ▶ Integrated all-around sealing as standard
- ▶ Same load capacity in all four directions of loading
- ▶ Can be used on all Ball Guide Rails SNS

## Product description

Up to 60% weight saving with high load-bearing capacity. The steel insert technology assures the same load capacities as the steel version up to the maximum load-bearing capability of the aluminum body.

### Detailed information:

Ball Rail Systems R310EN 2202 catalog

## Technical data

Size		15	20	25	30	35
$C^{1)}$	N	9 860	23 400	28 600	36 500	51 800
$F_{\max}^{1)}$	N	3 000	7 200	8 800	12 200	16 200
$M_t^{1)}$	Nm	95	300	410	630	1 110
$M_{t \max}^{1)}$	Nm	29	92	125	210	345
$M_L^{1)}$	Nm	68	200	290	440	720
$M_{L \max}^{1)}$	Nm	16	50	70	110	170
A	mm	47	63	70	90	100
B	mm	58.2	75	86.2	97.7	110.5
$H_1$	mm	19.9	25.35	29.9	35.35	40.4
m	kg	0.1	0.24	0.3	0.5	0.75

<sup>1)</sup> The load capacities (N) and moments (Nm) apply to Ball Runner Blocks without ball chain.

For ordering information for the GoTo products, see page 90.

# Standard Ball Runner Blocks, aluminum, SNS, Type R1632

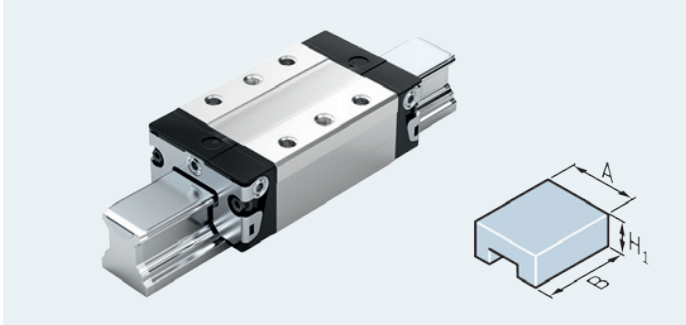

- ▶ High load-bearing capacity
- ▶ High torque load capacity
- ▶ For mounting from above
- ▶ Travel speed:  $v_{\max} = 5 \text{ m/s}$
- ▶ Acceleration:  $a_{\max} = 500 \text{ m/s}^2$

## Features

- ▶ Now with improved performance data
- ▶ Unrestricted interchangeability
- ▶ Integrated all-around sealing as standard
- ▶ Same load capacity in all four directions of loading
- ▶ Can be used on all Ball Guide Rails SNS

## Product description

Up to 60% weight saving with high load-bearing capacity. The steel insert technology assures the same load capacities as the steel version up to the maximum load-bearing capability of the aluminum body.

### Detailed information:

Ball Rail Systems R310EN 2202 catalog

## Technical data

Size		15	20	25	30	35
$C^{1)}$	N	9 860	23 400	28 600	36 500	51 800
$F_{\max}^{1)}$	N	3 000	7 200	8 800	12 200	16 200
$M_t^{1)}$	Nm	95	300	410	630	1 110
$M_{t \max}^{1)}$	Nm	29	92	125	210	345
$M_L^{1)}$	Nm	68	200	290	440	720
$M_{L \max}^{1)}$	Nm	16	50	70	110	170
A	mm	34	44	48	60	70
B	mm	58.2	75	86.2	97.7	110.5
$H_1$	mm	19.9	25.35	29.9	35.35	40.4
m	kg	0.1	0.2	0.35	0.45	0.65

<sup>1)</sup> The load capacities (N) and moments (Nm) apply to Ball Runner Blocks without ball chain.

## Standard Ball Guide Rails, steel, SNS, Type R1605 .0, with plastic mounting hole plugs

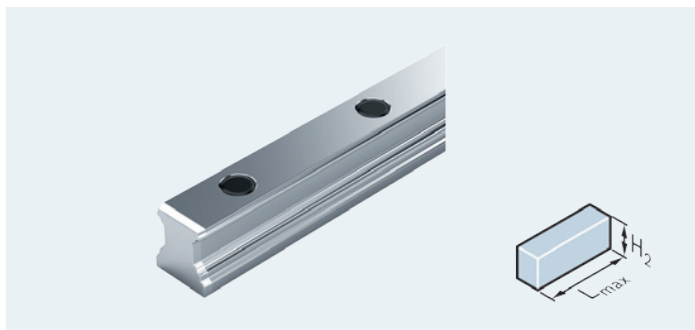

- ▶ For mounting from above
- ▶ No extra space needed at rail ends
- ▶ Available in accuracy classes N, H, P

### Features

- ▶ Top rigidity in all load directions
- ▶ High torque load capacity
- ▶ One-piece version

### Product description

The highly accurate precision-ground ball guide rails have reference edges on both sides. The optimally shaped chamfers around the edges of the end faces make it easier to push on the runner blocks and protect the seals from being damaged during this process.

### Detailed information:

Ball Rail Systems R310EN 2202 catalog

### Technical data

Size		15	20	25	30	35	45
$L_{max}$	mm	3 836	3 836	3 836	3 836	3 836	3 776
$H_2$	mm	16.2	20.55	24.25	28.35	31.85	39.85
m	kg/m	1.4	2.4	3.2	5	6.8	10.5

For ordering information for the GoTo products, see page 91.



## Standard Ball Guide Rails, steel, SNS, Type R1605 .6, with cover strip and protective end caps

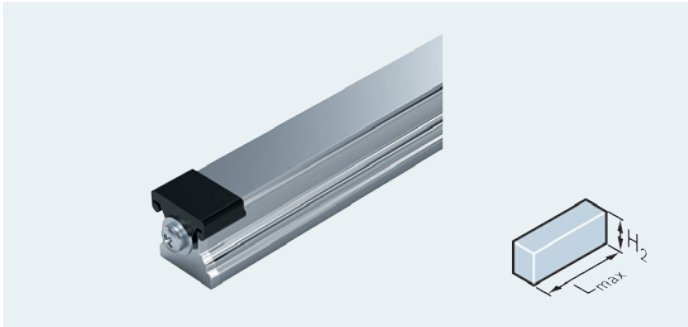

- ▶ For mounting from above
- ▶ Cover strip made of corrosion-resistant spring steel
- ▶ With threaded holes at the end faces
- ▶ Screw-down plastic protective end caps
- ▶ Available in accuracy classes N, H, P

### Features

- ▶ Top rigidity in all load directions
- ▶ High torque load capacity
- ▶ For harsh environments
- ▶ Compact cover strip fastening
- ▶ A single cover for all holes
- ▶ One-piece version

### Product description

The highly accurate precision-ground ball guide rails have reference edges on both sides. The optimally shaped chamfers around the edges of the end faces make it easier to push on the runner blocks and protect the seals from being damaged during this process.

Cover strip made of corrosion-resistant spring steel per EN 10088.

### Detailed information:

Ball Rail Systems R310EN 2202 catalog

### Technical data

Size		15	20	25	30	35	45
L <sub>max</sub>	mm	3 836	3 836	3 836	3 836	3 836	3 776
H <sub>2</sub>	mm	16.3	20.75	24.45	28.55	32.15	40.15
m	kg/m	1.4	2.4	3.2	5	6.8	10.5

For ordering information for the GoTo products, see page 91.

## Standard Ball Guide Rails, steel, SNS, Type R1607, for mounting from below

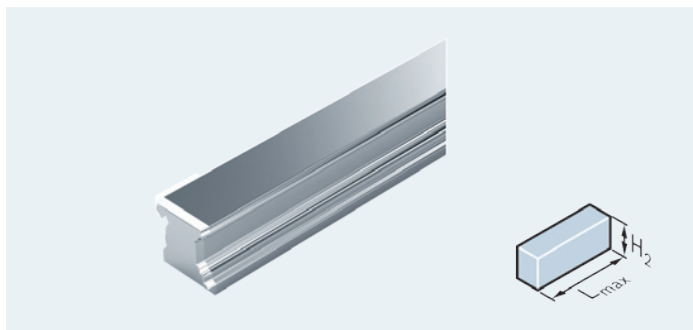

- ▶ For mounting from below
- ▶ Greater side loads permitted
- ▶ No extra space needed at rail ends
- ▶ Easy access to mounting base underside
- ▶ Available in accuracy classes N, H, P

### Features

- ▶ Top rigidity in all load directions
- ▶ High torque load capacity
- ▶ One-piece version
- ▶ Best sealing action of end seals

### Product description

The highly accurate precision-ground ball guide rails have reference edges on both sides. The optimally shaped chamfers around the edges of the end faces make it easier to push on the runner blocks and protect the seals from being damaged during this process.

### Detailed information:

Ball Rail Systems R310EN 2202 catalog

### Technical data

Size		15	20	25	30	35	45
$L_{max}$	mm	3 836	3 836	3 836	3 836	3 836	3 776
$H_2$	mm	16.2	20.55	24.25	28.35	31.85	39.85
m	kg/m	1.4	2.4	3.2	5	6.8	10.5

For ordering information for the GoTo products, see page 92.

## Wide Ball Runner Blocks, steel, BNS, Type R1671

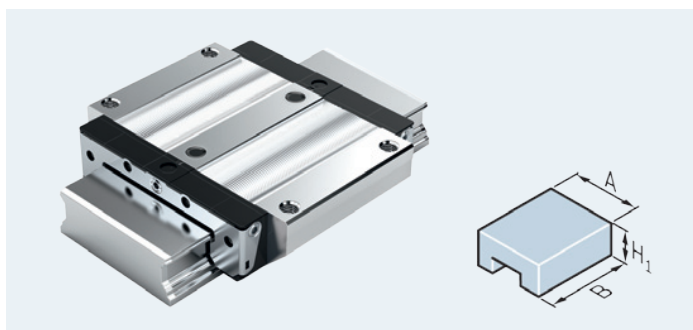

- ▶ Excellent dynamic characteristics
- ▶ Very high torsional moment load capacity
- ▶ Very high torsional rigidity
- ▶ High torque load capacity

### Features

- ▶ Now with improved performance data
- ▶ Unrestricted interchangeability
- ▶ For mounting from above and below
- ▶ Same high load capacities in all four major planes of load application

### Product description

High rigidity in all load directions – permits applications with just one runner block per rail. Unrestricted interchangeability means that all Rexroth ball runner blocks and ball guide rails within one accuracy class can be combined at will.

### Detailed information:

Ball Rail Systems R310EN 2202 catalog

### Technical data

Size		20/40	25/70	35/90
$C^{1)}$	N	14 900	36 200	70 700
$M_t^{1)}$	Nm	340	1 350	3 500
$M_L^{1)}$	Nm	140	490	1 470
A	mm	80	120	162
B	mm	73	105	142
$H_1$	mm	22.50	29.75	42.50
m	kg	0.4	1.2	3.7
$v_{max}$	m/s	5	5	3
$a_{max}$	m/s <sup>2</sup>	500	500	250

<sup>1)</sup> The load capacities (N) and moments (Nm) apply to Ball Runner Blocks without ball chain.

## Wide Ball Guide Rails, steel, BNS, Type R1675 .0, With plastic mounting hole plugs

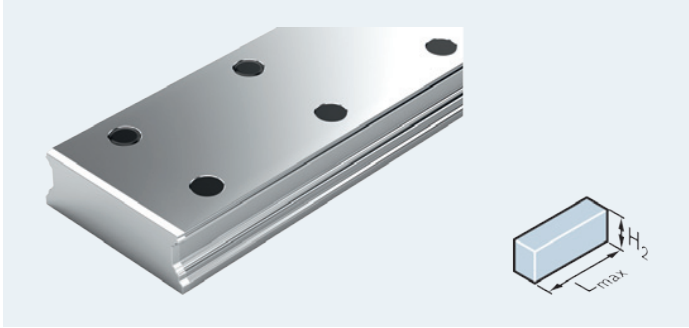

- ▶ Very high rigidity in all load directions
- ▶ Very high torque capacity
- ▶ For mounting from above

### Features

- ▶ Accuracy classes N and H
- ▶ With two-row mounting hole pattern

### Product description

The highly accurate precision-ground ball guide rails have reference edges on both sides. The optimally shaped chamfers around the edges of the end faces make it easier to push on the runner blocks and protect the seals from being damaged during this process.

### Detailed information:

Ball Rail Systems R310EN 2202 catalog

### Technical data

Size		20/40	25/70	35/90
$L_{max}$	mm	3 836	3 836	3 836
$H_2$	mm	18.30	23.55	31.85
m	kg/m	5.30	11.60	21.00

For ordering information for the GoTo products, see page 92.

Bosch Rexroth AG, R310EN 2060, 2014-05

# Standard Ball Runner Blocks NRF, steel, FNS, Type R2001

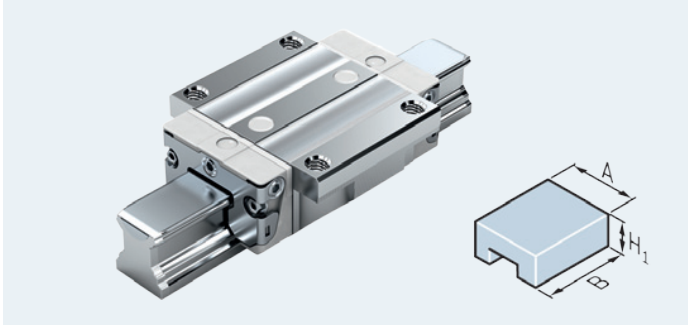

- ▶ High load-bearing capacity
- ▶ Excellent dynamic characteristics
- ▶ Same load capacity in all four directions of loading
- ▶ Also suitable for environments with a relative humidity of over 70 % and temperatures above 30 °C.

## Features

- ▶ Now with improved performance data
- ▶ All metal parts made of corrosion-resistant steel
- ▶ All plastic parts made of certified material as per Directive 2002/72/EC and FDA21CFR.
- ▶ Integrated all-round sealing
- ▶ No additional corrosion protection needed

## Product description

Corrosion-resistant ball runner blocks with special FG (food grade) features for use in the packaging industry and areas of the food industry.

### Detailed information:

Ball Rail Systems NRF R310EN 2226 catalog

## Technical data

Size		15	20	25	30	35
C <sup>1)</sup>	N	6 480	15 300	18 800	24 000	34 000
M <sub>t</sub> <sup>1)</sup>	Nm	63	200	270	420	730
M <sub>L</sub> <sup>1)</sup>	Nm	44	130	190	290	480
A	mm	47	63	70	90	100
B	mm	58.2	75.0	86.2	97.7	110.5
H <sub>1</sub>	mm	19.90	25.35	29.90	35.35	40.40
m	kg	0.20	0.45	0.65	1.10	1.60

<sup>1)</sup> The load capacities (N) and moments (Nm) apply to Ball Runner Blocks without ball chain.



## Standard Ball Runner Blocks NRRFG, steel, FLS, Type R2002

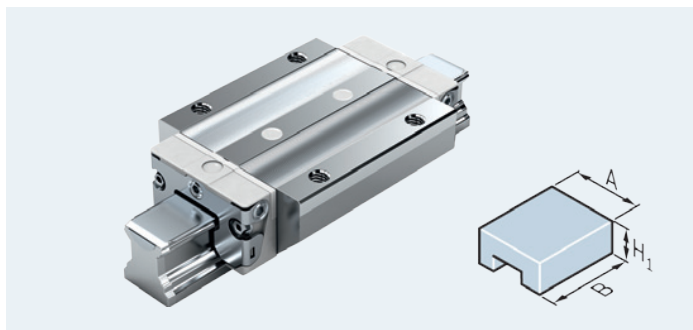

- ▶ Very high load capacity
- ▶ Excellent dynamic characteristics
- ▶ Also suitable for environments with a relative humidity of over 70 % and temperatures above 30 °C.
- ▶ No additional corrosion protection needed

### Features

- ▶ Now with improved performance data
- ▶ All metal parts made of corrosion-resistant steel
- ▶ All plastic parts made of certified material as per Directive 2002/72/EC and FDA21CFR.
- ▶ Integrated all-round sealing

### Product description

Corrosion-resistant ball runner blocks with special FG (food grade) features for use in the packaging industry and areas of the food industry.

#### Detailed information:

Ball Rail Systems NRRFG R310EN 2226 catalog

### Technical data

Size		15	20	25	30	35
C <sup>1)</sup>	N	8 400	19 500	24 500	30 200	43 900
M <sub>t</sub> <sup>1)</sup>	Nm	81	250	350	520	940
M <sub>L</sub> <sup>1)</sup>	Nm	80	230	350	490	840
A	mm	47	63	70	90	100
B	mm	72.6	91.0	107.9	119.7	139.0
H <sub>1</sub>	mm	19.90	25.35	29.90	35.35	40.40
m	kg	0.30	0.55	0.90	1.50	2.25

<sup>1)</sup> The load capacities (N) and moments (Nm) apply to Ball Runner Blocks without ball chain.

For ordering information for the GoTo products, see page 92.

# Standard Ball Runner Blocks NRF, steel, SNS, Type R2011

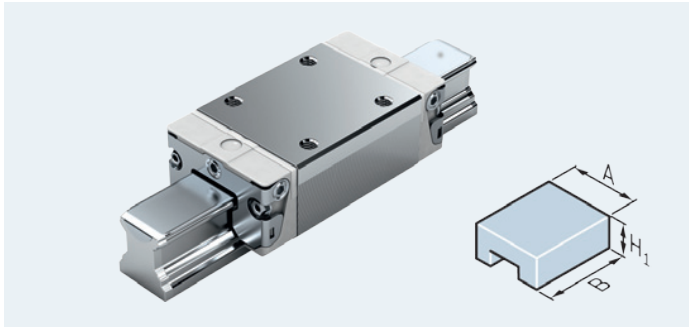

- ▶ For restricted space in the transverse direction
- ▶ Excellent dynamic characteristics
- ▶ Same load capacity in all four directions of loading
- ▶ Also suitable for environments with a relative humidity of over 70 % and temperatures above 30 °C.

## Features

- ▶ All metal parts made of corrosion-resistant steel
- ▶ All plastic parts made of certified material as per Directive 2002/72/EC and FDA21CFR.
- ▶ Integrated all-round sealing
- ▶ No additional corrosion protection needed

## Product description

Corrosion-resistant ball runner blocks with special FG (food grade) features for use in the packaging industry and areas of the food industry.

### Detailed information:

Ball Rail Systems NRF R310EN 2226 catalog

## Technical data

Size		15	20	25	30	35
C <sup>1)</sup>	N	6 480	15 300	18 800	24 000	34 000
M <sub>t</sub> <sup>1)</sup>	Nm	63	200	270	420	730
M <sub>L</sub> <sup>1)</sup>	Nm	44	130	190	290	480
A	mm	34	44	48	60	70
B	mm	58.2	75.0	86.2	97.7	110.5
H <sub>1</sub>	mm	19.90	25.35	29.90	35.35	40.40
m	kg	0.15	0.35	0.50	0.85	1.25

<sup>1)</sup> The load capacities (N) and moments (Nm) apply to Ball Runner Blocks without ball chain.

## Standard Ball Runner Blocks NRFG, steel, SLS, Type R2012

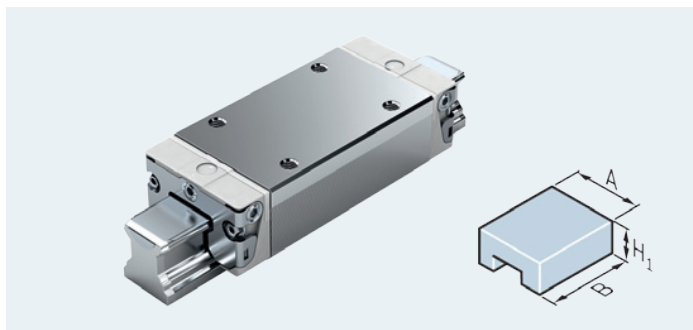

- ▶ Very high load capacity
- ▶ For restricted space in the transverse direction
- ▶ Excellent dynamic characteristics
- ▶ Also suitable for environments with a relative humidity of over 70 % and temperatures above 30 °C.

### Features

- ▶ Now with improved performance data
- ▶ All metal parts made of corrosion-resistant steel
- ▶ All plastic parts made of certified material as per Directive 2002/72/EC and FDA21CFR.
- ▶ Integrated all-round sealing
- ▶ No additional corrosion protection needed

### Product description

Corrosion-resistant ball runner blocks with special FG (food grade) features for use in the packaging industry and areas of the food industry.

#### Detailed information:

Ball Rail Systems NRFG R310EN 2226 catalog

### Technical data

Size		15	20	25	30	35
C <sup>1)</sup>	N	8 400	19 500	24 500	30 200	43 900
M <sub>t</sub> <sup>1)</sup>	Nm	81	250	350	520	940
M <sub>L</sub> <sup>1)</sup>	Nm	80	230	350	490	840
A	mm	34	44	48	60	70
B	mm	72.6	91.0	107.9	119.7	139.0
H <sub>1</sub>	mm	19.90	25.35	29.90	35.35	40.40
m	kg	0.20	0.45	0.65	1.10	1.70

<sup>1)</sup> The load capacities (N) and moments (Nm) apply to Ball Runner Blocks without ball chain.

For ordering information for the GoTo products, see page 93.

## Ball Guide Rails Resist NR II, SNS, Type R2045 .0, With plastic mounting hole plugs

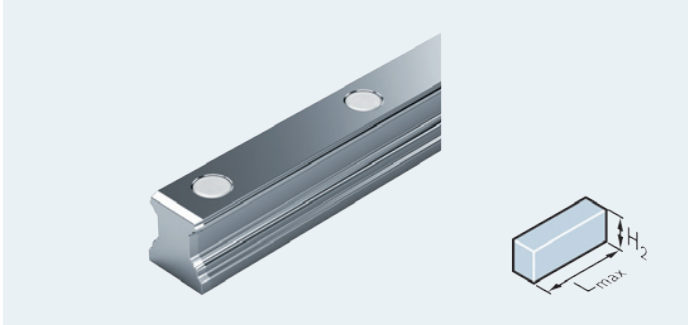

- ▶ For mounting from above
- ▶ Very high rigidity in all load directions
- ▶ Very high torque capacity
- ▶ Made of corrosion-resistant steel per EN 10088

### Features

- ▶ Also suitable for environments with a relative humidity of over 70 % and temperatures above 30°C.
- ▶ All plastic parts made of certified material as per Directive 2002/72/EC and FDA21CFR.
- ▶ No additional corrosion protection needed

### Product description

The highly accurate precision-ground ball guide rails have reference edges on both sides. The optimally shaped chamfers around the edges of the end faces make it easier to push on the runner blocks and protect the seals from being damaged during this process. Ball guide rails in Resist NR II are specifically intended for use in applications involving aqueous media.

### Detailed information:

Ball Rail Systems NRRG R310EN 2226 catalog

### Technical data

Size		15	20	25	30	35
L <sub>max</sub>	mm	1 856	3 836	3 836	3 836	3 836
H <sub>2</sub>	mm	16.20	20.55	24.25	28.35	31.85
m	kg/m	1.4	2.4	3.2	5.0	6.8

For ordering information for the GoTo products, see page 93.



# Miniature Ball Rail Systems

The Miniature versions of Ball Rail Systems were developed specifically for compact applications in medical and automation technology and for the electrical industry. These industries in particular often require rolling-element linear guides with extremely small dimensions but high load capacities. Rexroth products in these small sizes deliver outstanding performance. Having the same high load capacities in all four main directions of loading, these ball guide units provide optimal solutions to meet the very special requirements of these manufacturing segments. Cleanroom applications can also be served, and appropriate certifications have been obtained.

## Miniature Ball Runner Blocks

High load capacities in all load directions, including moments about all axes, due to the use of largest possible ball sizes.

## Miniature Ball Guide Rails

Utmost precision thanks to highly accurate machining.

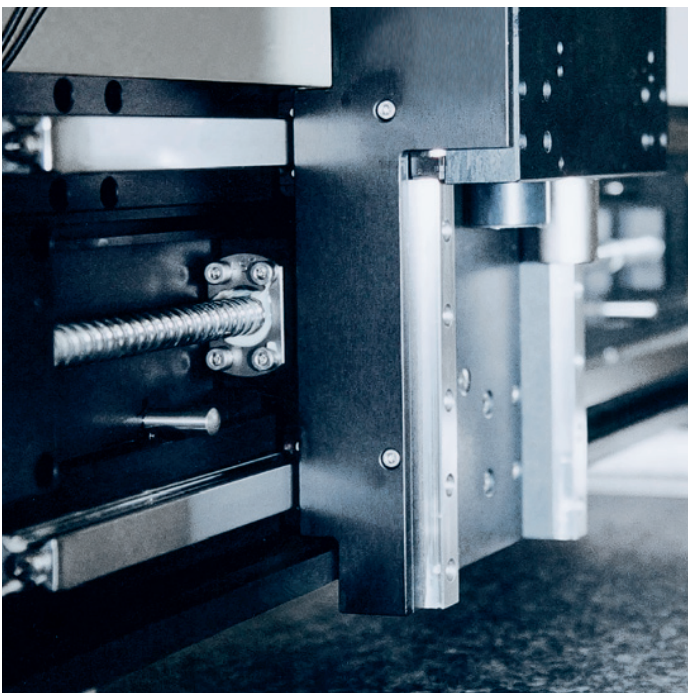

## Miniature Ball Runner Blocks, standard, Type R0442

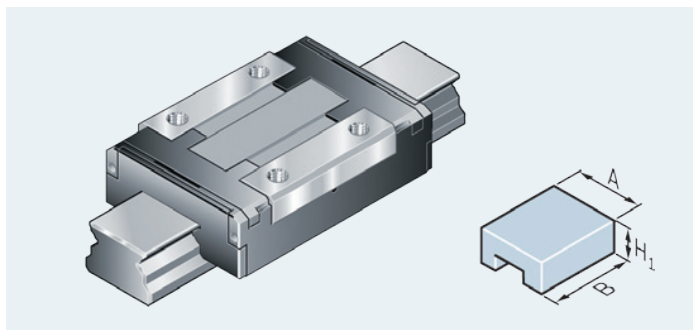

- ▶ Extremely compact dimensions
- ▶ High load-bearing capacity

### Features

- ▶ Unrestricted interchangeability within the same accuracy class
- ▶ All steel parts made of rust and acid resistant material
- ▶ Same load capacity in all four main directions of loading
- ▶ Easy mounting and replacement without loss of balls due to special ball retention feature

### Product description

Miniature Ball Rail Systems are rolling-element linear guides in extremely compact dimensions with high load-bearing capability.

### Detailed information:

Miniature Ball Rail Systems R310EN 2210 catalog

### Technical data

Size		<b>7</b>	<b>9</b>	<b>12</b>	<b>15</b>	<b>20</b>
C	N	860	1 180	2 310	4 200	7 900
$M_t$	Nm	3.1	5.4	13.7	31.2	81.4
$M_L$	Nm	1.9	3.6	7.9	18.3	51.7
A	mm	17	20	27	32	46
B	mm	24	31	34.8	43	66
$H_1$	mm	8	10	13	16	25
m	g	9	16	33	47	177

For ordering information for the GoTo products, see page 93.



## Miniature Ball Runner Blocks, long, Type R0444

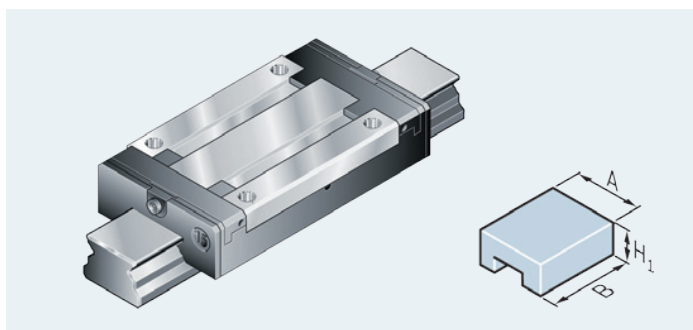

- ▶ Extremely compact dimensions
- ▶ High load-bearing capacity
- ▶ Long version

### Features

- ▶ Unrestricted interchangeability within the same accuracy class
- ▶ All steel parts made of rust and acid resistant material
- ▶ Same load capacity in all four main directions of loading
- ▶ Easy mounting and replacement without loss of balls due to special ball retention feature

### Product description

Miniature Ball Rail Systems are rolling-element linear guides in extremely compact dimensions with high load-bearing capability.

### Detailed information:

Miniature Ball Rail Systems R310EN 2210 catalog

### Technical data

Size		7	9	12	15
C	N	1 220	1 570	3 240	5 940
$M_t$	Nm	4.5	7.2	19.3	44.0
$M_L$	Nm	4.3	7.0	16.8	39.2
A	mm	17	20	27	32
B	mm	33	41.4	47.5	60.8
$H_1$	mm	8	10	13	16
m	g	14	26	51	94

For ordering information for the GoTo products, see page 93.

**Miniature Ball Guide Rails**

# Miniature Ball Guide Rails, standard, without cover strip, Type R0445



► For mounting from above

**Features**

► For standard and long Miniature Ball Runner Blocks

**Product description**

Miniature ball guide rails are made of rust and acid resistant material similar to ISO 683-17/EN 10088.

**Detailed information:**

Miniature Ball Rail Systems R310EN 2210 catalog

**Technical data**

Size		<b>7</b>	<b>9</b>	<b>12</b>	<b>15</b>	<b>20</b>
L <sub>max</sub>	mm	1 000	1 000	1 000	1 000	1 000
H <sub>2</sub>	mm	4.7	5.5	7.8	9.5	15
m	g/100 mm	22	33	61	97	211

For ordering information for the GoTo products, see page 94.

## Miniature Ball Runner Blocks, wide, Type R0443

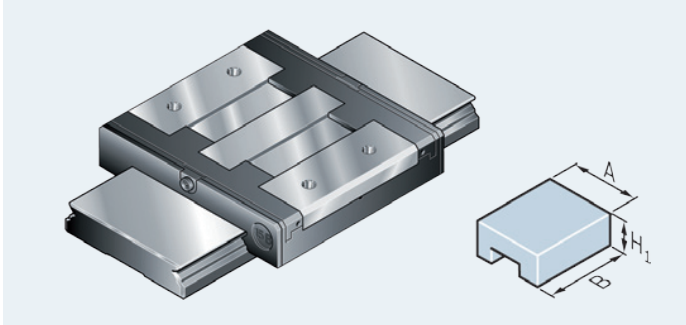

- ▶ Extremely compact dimensions
- ▶ High load-bearing capacity
- ▶ Wide version
- ▶ High torque load capacity
- ▶ Suitable for one-rail applications

### Features

- ▶ Unrestricted interchangeability within the same accuracy class
- ▶ All steel parts made of rust and acid resistant material
- ▶ Same load capacity in all four main directions of loading
- ▶ Easy mounting and replacement without loss of balls due to special ball retention feature

### Product description

Miniature Ball Rail Systems are rolling-element linear guides in extremely compact dimensions with high load-bearing capability.

### Detailed information:

Miniature Ball Rail Systems R310EN 2210 catalog

### Technical data

Size		<b>9</b>	<b>12</b>	<b>15</b>
C	N	1 920	3 200	5 285
$M_t$	Nm	15.9	37.9	107.0
$M_L$	Nm	7.4	14.3	30.0
A	mm	30	40	60
B	mm	39	44.5	55.5
$H_1$	mm	12	14	16
m	g	26	51	110

For ordering information for the GoTo products, see page 94.

## Miniature Ball Runner Blocks, wide, long, Type R0441

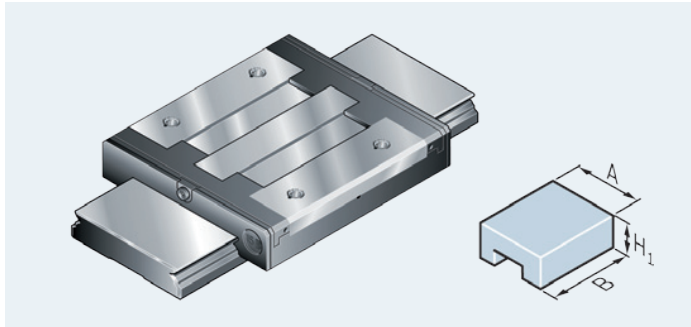

- ▶ Extremely compact dimensions
- ▶ High load-bearing capacity
- ▶ Wide and long version
- ▶ High torque load capacity
- ▶ Suitable for one-rail applications

### Features

- ▶ Unrestricted interchangeability within the same accuracy class
- ▶ All steel parts made of rust and acid resistant material
- ▶ Same load capacity in all four main directions of loading
- ▶ Easy mounting and replacement without loss of balls due to special ball retention feature

### Product description

Miniature Ball Rail Systems are rolling-element linear guides in extremely compact dimensions with high load-bearing capability.

### Detailed information:

Miniature Ball Rail Systems R310EN 2210 catalog

### Technical data

Size		<b>9</b>	<b>12</b>	<b>15</b>
C	N	2 825	4 340	7 460
$M_t$	Nm	23.5	51.4	151.0
$M_L$	Nm	15.8	28.7	66.1
A	mm	30	40	60
B	mm	51	59.5	74.5
$H_1$	mm	12	14	16
m	g	41	76	170

For ordering information for the GoTo products, see page 94.

## Miniature Ball Guide Rails, wide, without cover strip, Type R0455

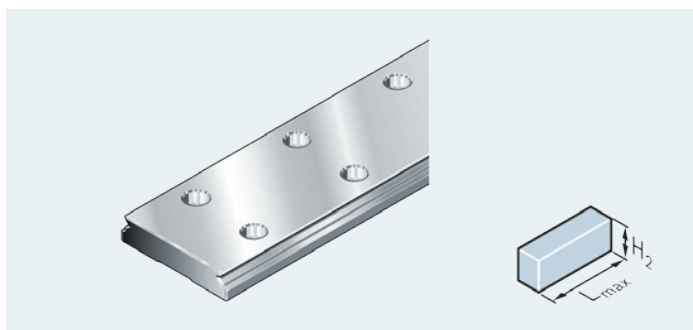

- ▶ For mounting from above
- ▶ Size 15 with two rows of mounting holes
- ▶ High torque load capacity
- ▶ Suitable for one-rail applications

### Features

- ▶ For wide and wide, long Miniature Ball Runner Blocks

### Product description

Miniature ball guide rails are made of rust and acid resistant material similar to ISO 683-17/EN 10088.

### Detailed information:

Miniature Ball Rail Systems R310EN 2210 catalog

### Technical data

Size		9	12	15
$L_{max}$	mm	1 000	1 000	1 000
$H_2$	mm	7.5	8.5	9.5
m	g/100 mm	92	145	286

For ordering information for the GoTo products, see page 94.



# Linear Bushings and Shafts

Linear Bushings guides from Rexroth have proved their worth over many decades. Their uses are practically unlimited. The great diversity of sizes, designs and versions opens up applications beyond the classic areas of general and special-purpose machinery, jigs and fixtures, enabling powerful solutions for tasks in, for example, the food, semiconductor and medical technology industries. Linear Bushings show impressive performance in environmental conditions involving heavy contamination or high thermal loads. They are also renowned for their long life, accuracy and high degree of efficiency.

## Linear Bushings

For short-stroke applications, self-supporting guides with closed-type Linear Bushings are the best choice even in harsh conditions. The GoTo Program now includes a broad selection of Linear Bushings ranging from Compact and Segmental designs to all varieties of Super Linear Bushings, and of course the rugged Standard Linear Bushing.

## Linear Sets

Utmost precision thanks to highly accurate machining. Ready-to-mount units for cost-effective implementation.

## Precision Steel Shafts

Broad application spectrum with cut-to-length precision shafts in various tolerances made of heat-treated steel and corrosion-resistant steel as well as hard chrome plated.

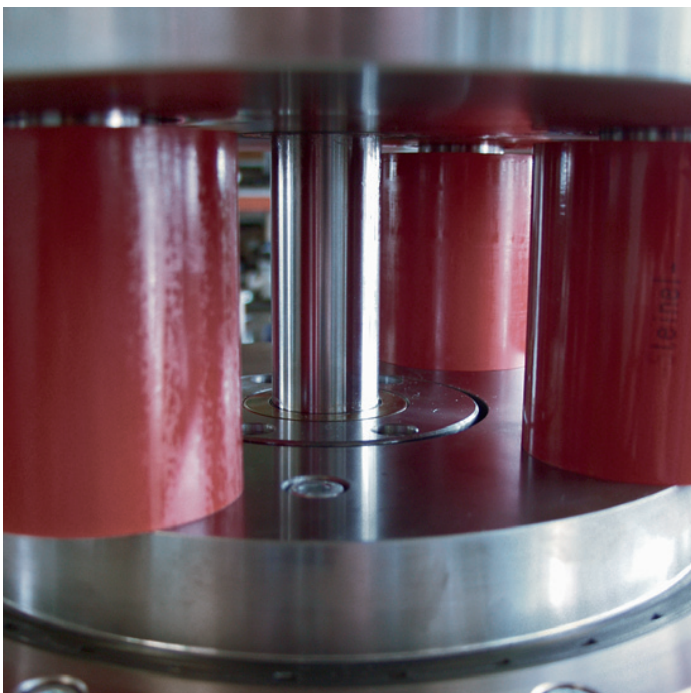



## Compact Linear Bushings, closed, Type R0658, shaft diameter 8 to 10

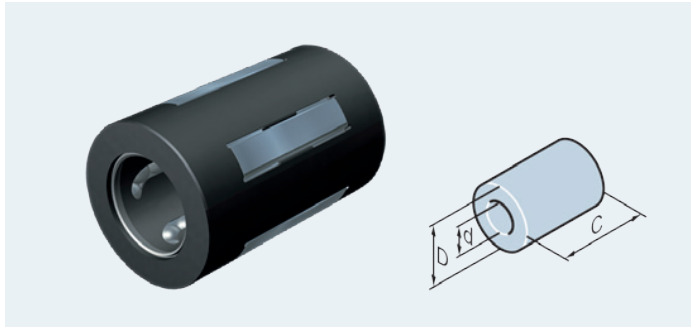

- ▶ Small outside dimensions
- ▶ High travel speed (5 m/s)
- ▶ With two integrated wiper seals
- ▶ Closed-type construction form for self-supporting shafts
- ▶ POM ball retainer

### Features

- ▶ Also available in corrosion-resistant steels as per ISO 683-17/EN 10088

### Product description

Space-saving Linear Bushings with small outside dimensions for especially compact constructions. High load capacities and long service life due to hardened segmental steel plates with ball conformity in the running track. Many pockets acting as lubricant reservoirs for extended lubrication intervals or lubrication for life. Pockets also whisk away any dirt that may have worked its way in and so prevent jamming of the linear bushing.

### Detailed information:

Linear Bushings and Shafts R310EN 3100 catalog

### Technical data

Shaft diameter d	mm	8	10
$C_{max}$	N	580	720
$C_{max}$ corrosion-resistant	N	410	500
$C_{0\ max}$	N	500	600
$C_{0\ max}$ corrosion-resistant	N	400	480
$v_{max}$	m/s	5	5
$a_{max}$	m/s <sup>2</sup>	150	150
D	mm	15	17
Length C	mm	24	26
m	kg	0.011	0.014

For ordering information for the GoTo products, see page 95.

## Compact Linear Bushings, closed, Type R0658, shaft diameter 12 to 50

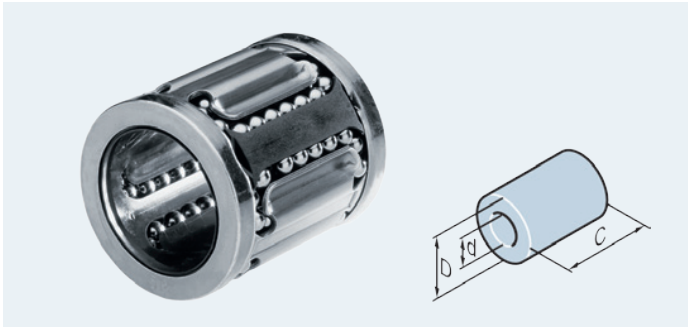

- ▶ Small outside dimensions
- ▶ High travel speed (5 m/s)
- ▶ With two integrated wiper seals
- ▶ Closed-type construction form for self-supporting shafts
- ▶ Integrated metal retaining rings

### Features

- ▶ Also available in corrosion-resistant steels as per ISO 683-17/EN 10088
- ▶ Easy press-fit mounting – no additional retention necessary

### Product description

Space-saving Linear Bushings with small outside dimensions for especially compact constructions. High load capacities and long service life due to hardened segmental steel plates with ball conformity in the running track. Many pockets acting as lubricant reservoirs for extended lubrication intervals or lubrication for life. Pockets also whisk away any dirt that may have worked its way in and so prevent jamming of the linear bushing.

### Detailed information:

Linear Bushings and Shafts R310EN 3100 catalog

### Technical data

Shaft diameter d	mm	12	16	20	25	30	40	50
$C_{max}$	N	870	1 120	1 410	2 930	3 250	6 380	7 180
$C_{max}$ corrosion-resistant	N	610	780	990	2 050	2 700	4 470	5 030
$C_{0\ max}$	N	620	730	900	1 950	2 790	4 650	5 350
$C_{0\ max}$ corrosion-resistant	N	500	580	720	1 560	2 230	3 720	4 280
$v_{max}$	m/s	5	5	5	5	5	5	5
$a_{max}$	m/s <sup>2</sup>	150	150	150	150	150	150	150
D	mm	19	24	28	35	40	52	62
Length C	mm	28	30	30	40	50	60	70
m	kg	0.016	0.025	0.028	0.058	0.080	0.140	0.170

For ordering information for the GoTo products, see page 95.

## Linear Sets with Compact Linear Bushings, closed, normal or corrosion-resistant, Type R1027

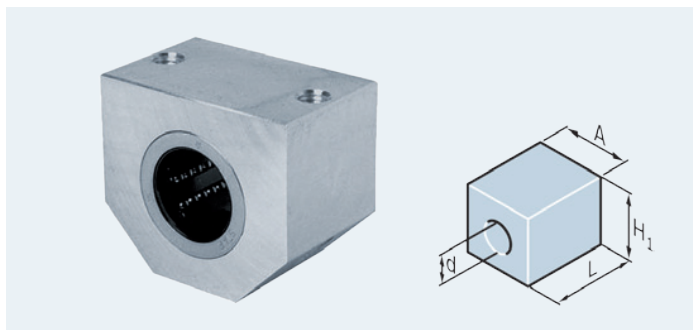

- ▶ Precision, lightweight housing (aluminum)
- ▶ With integrated wiper seals
- ▶ With normal radial clearance

### Features

- ▶ Pre-lubricated
- ▶ Also available in corrosion-resistant version (per ISO 683-17/EN 10088)

### Product description

Linear Sets are complete bearing units consisting of a housing with a Rexroth linear bushing. They are available in many different configurations. Because of their rationalized construction and fabrication, they offer users significant cost advantages over customer-built designs.

### Detailed information:

Linear Bushings and Shafts R310EN 3100 catalog

### Technical data

Shaft diameter d	mm	12	16	20	25	30	40	50
C <sup>1)</sup>	N	810	1 050	1 410	2 930	3 850	6 830	7 180
C <sup>1)</sup> corrosion-resistant	N	570	730	990	2 050	2 700	4 470	5 030
C <sub>0</sub> <sup>1)</sup>	N	490	570	900	1 950	2 790	4 650	5 350
C <sub>0</sub> <sup>1)</sup> corrosion-resistant	N	390	460	720	1 560	2 230	3 720	4 280
H <sub>1</sub>	mm	33	38	45	54	60	76	92
L	mm	28	30	30	40	50	60	70
A	mm	40	45	53	62	67	87	103
m	kg	0.08	0.11	0.15	0.27	0.40	0.75	1.20

<sup>1)</sup> The load capacities apply for the main direction of loading.

For ordering information for the GoTo products, see page 95.

Bosch Rexroth AG, R310EN 2060, 2013-09

# Linear Sets with Compact Linear Bushings, adjustable, Type R1028

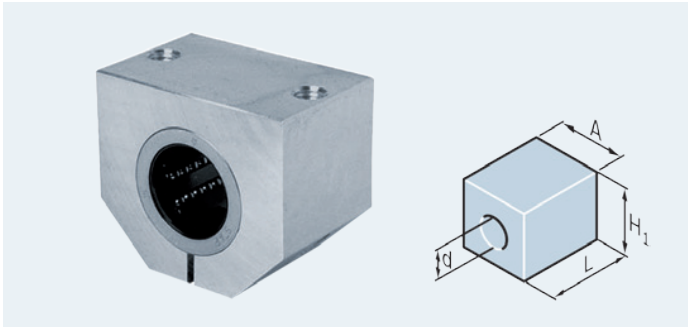

- ▶ Precision, lightweight housing (aluminum)
- ▶ With integrated wiper seals
- ▶ Radial clearance adjustable

## Features

- ▶ Pre-lubricated

## Product description

Linear Sets are complete bearing units consisting of a housing with a Rexroth linear bushing. They are available in many different configurations. Because of their rationalized construction and fabrication, they offer users significant cost advantages over customer-built designs.

### Detailed information:

Linear Bushings and Shafts R310EN 3100 catalog

## Technical data

Shaft diameter d	mm	12	16	20	25	30	40	50
C <sup>1)</sup>	N	810	1 050	1 410	2 930	3 850	6 830	7 180
C <sub>0</sub> <sup>1)</sup>	N	490	570	900	1 950	2 790	4 650	5 350
H <sub>1</sub>	mm	33	38	45	54	60	76	92
L	mm	28	30	30	40	50	60	70
A	mm	40	45	53	62	67	87	103
m	kg	0.08	0.11	0.15	0.27	0.40	0.75	1.20

<sup>1)</sup> The load capacities apply for the main direction of loading.

## Super Linear Bushings **A**, closed, Type R0670

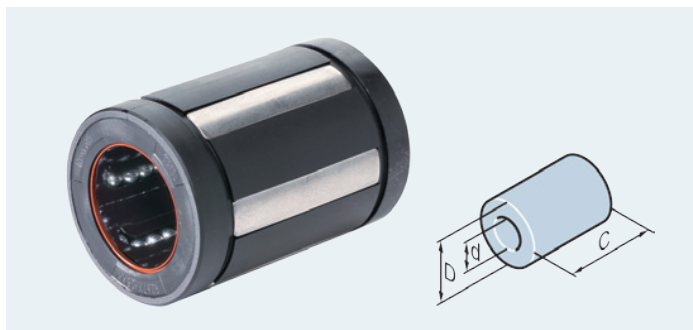

- ▶ Very high load capacity
- ▶ Unsurpassed, smooth ball circulation
- ▶ Compensation of misalignments
- ▶ Long service life
- ▶ High travel speed (up to 5 m/s)

### Features

- ▶ Hardened steel segmental load bearing plates with ground ball tracks
- ▶ Ball retainer and outer sleeve made of POM
- ▶ Balls made of anti-friction bearing steel
- ▶ With or without two integrated wiper seals

### Product description

The Super Linear Bushings have a built-in self-alignment capability. This compensates for angular alignment errors of up to 0.5 degrees without any reduction in load capacity. As a result, the Super Linear Bushings offer unparalleled smooth motion, a very high load-carrying capacity, and an extremely long service life.

### Detailed information:

Linear Bushings and Shafts R310EN 3100 catalog

### Technical data

Shaft diameter d	mm	10	12	16	20	25	30	40	50
$C_{max}$	N	820	1 140	1 400	2 470	4 820	5 860	10 070	14 730
$C_{0 max}$	N	480	620	780	1 340	2 790	3 570	5 570	8 280
$v_{max}^{1)}$	m/s	3	3	3	3	3	3	3	3
$a_{max}$	m/s <sup>2</sup>	150	150	150	150	150	150	150	150
D	mm	19	22	26	32	40	47	62	75
Length C	mm	29	32	36	45	58	68	80	100
m	kg	0.017	0.023	0.028	0.061	0.122	0.185	0.360	0.580

<sup>1)</sup> Up to 5 m/s possible (increased wear on the plastic parts).

For ordering information for the GoTo products, see page 95.

# Linear Sets with Super Linear Bushings **A**, closed, Type R1035

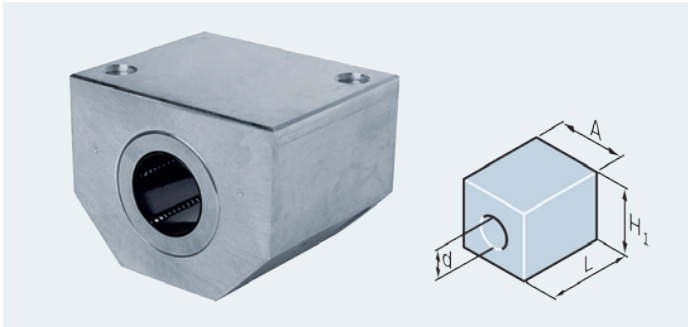

- ▶ Precision, lightweight housing (aluminum)
- ▶ Super Linear Bushing with self-alignment feature
- ▶ With two external seals

## Features

- ▶ Fully sealed

## Product description

Linear Sets are complete bearing units consisting of a housing with a Rexroth linear bushing. They are available in many different configurations. Because of their rationalized construction and fabrication, they offer users significant cost advantages over customer-built designs.

### Detailed information:

Linear Bushings and Shafts R310EN 3100 catalog

## Technical data

Shaft diameter d	mm	12	16	20	25	30	40	50
C <sup>1)</sup>	N	1 020	1 250	2 470	4 820	5 860	10 070	14 730
C <sub>0</sub> <sup>1)</sup>	N	490	620	1 340	2 790	3 570	5 570	8 280
H <sub>1</sub>	mm	35	42	50	60	70	90	105
L	mm	39	43	54	67	79	91	113
A	mm	42	53	60	78	87	108	132
m	kg	0.13	0.20	0.34	0.65	0.97	1.80	3.00

<sup>1)</sup> The load capacities apply for the main direction of loading.

## Linear Sets with Super Linear Bushings **A**, adjustable, Type R1036



- ▶ Precision, lightweight housing (aluminum)
- ▶ Super Linear Bushing with self-alignment feature
- ▶ With two external seals
- ▶ Radial clearance adjustable

### Features

- ▶ Fully sealed

### Product description

Linear Sets are complete bearing units consisting of a housing with a Rexroth linear bushing. They are available in many different configurations. Because of their rationalized construction and fabrication, they offer users significant cost advantages over customer-built designs.

### Detailed information:

Linear Bushings and Shafts R310EN 3100 catalog

### Technical data

Shaft diameter d	mm	12	16	20	25	30	40	50
C <sup>1)</sup>	N	1 020	1 250	2 470	4 820	5 860	10 070	14 730
C <sub>0</sub> <sup>1)</sup>	N	490	620	1 340	2 790	3 570	5 570	8 280
H <sub>1</sub>	mm	35	42	50	60	70	90	105
L	mm	39	43	54	67	79	91	113
A	mm	42	53	60	78	87	108	132
m	kg	0.13	0.20	0.34	0.65	0.97	1.80	3.00

<sup>1)</sup> The load capacities apply for the main direction of loading.

For ordering information for the GoTo products, see page 96.

Bosch Rexroth AG, R310EN 2060, 2013-09



# Linear Sets with Super Linear Bushings **A**, closed, tandem, Type R1085

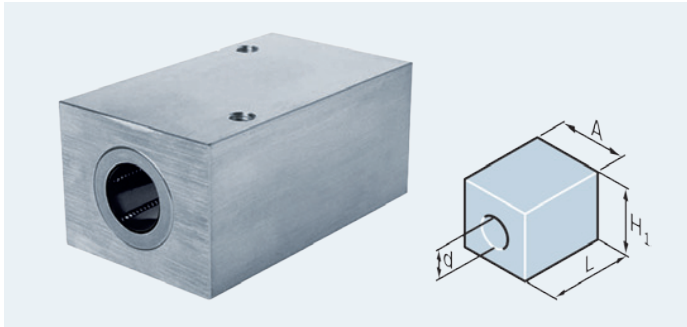

- ▶ Precision tandem housing, lightweight series (aluminum)
- ▶ Two Super Linear Bushings with self-alignment feature
- ▶ With two external seals

## Features

- ▶ Fully sealed

## Product description

The Linear Sets are complete bearing units consisting of a housing with two Rexroth linear bushings. They are available in many different configurations. Because of their rationalized construction and fabrication, they offer users significant cost advantages over customer-built designs.

### Detailed information:

Linear Bushings and Shafts R310EN 3100 catalog

## Technical data

Shaft diameter d	mm	12	16	20	25	30	40	50
C <sup>1)</sup>	N	1 660	2 030	4 010	7 830	9 520	16 360	23 930
C <sub>0</sub> <sup>1)</sup>	N	980	1 240	2 680	5 580	7 140	11 140	16 560
M <sub>L</sub>	Nm	26	35	84	205	289	576	1 097
M <sub>L0</sub>	Nm	16	22	54	140	206	374	725
H <sub>1</sub>	mm	35	42	50	60	70	90	105
L	mm	76	84	104	130	152	176	224
A	mm	42	50	60	74	84	108	130
m	kg	0.27	0.41	0.72	1.35	2.01	3.67	6.30

<sup>1)</sup> Load capacity when both Linear Bushings are equally loaded. The load capacities apply for the main direction of loading.

# Linear Sets with Super Linear Bushings **A**, adjustable, tandem, Type R1032

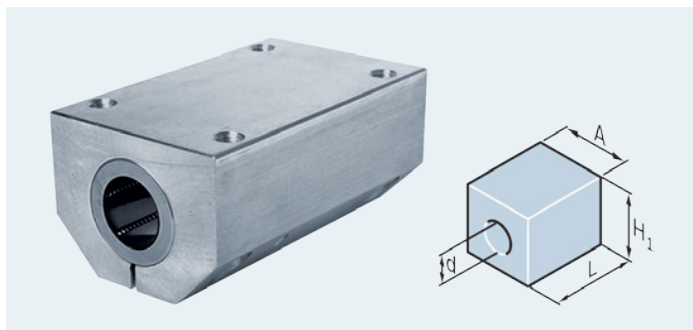

- ▶ Precision tandem housing, lightweight series (aluminum)
- ▶ Two Super Linear Bushings with self-alignment feature
- ▶ Radial clearance adjustable
- ▶ With reference edge

## Features

- ▶ With two external seals
- ▶ Fully sealed

## Product description

The Linear Sets are complete bearing units consisting of a housing with two Rexroth linear bushings. They are available in many different configurations. Because of their rationalized construction and fabrication, they offer users significant cost advantages over customer-built designs.

### Detailed information:

Linear Bushings and Shafts R310EN 3100 catalog

## Technical data

Shaft diameter d	mm	12	16	20	25	30	40	50
C <sup>1)</sup>	N	1 660	2 030	4 010	7 830	9 520	16 360	23 930
C <sub>0</sub> <sup>1)</sup>	N	980	1 240	2 680	5 580	7 140	11 140	16 560
M <sub>L</sub>	Nm	26	35	84	205	289	576	1 097
M <sub>L0</sub>	Nm	16	22	54	140	206	374	725
H <sub>1</sub>	mm	35	42	50	60	70	90	105
L	mm	76	84	104	130	152	176	224
A	mm	43	53	60	78	87	108	132
m	kg	0.27	0.41	0.72	1.35	2.01	3.67	6.30

<sup>1)</sup> Load capacity when both Linear Bushings are equally loaded. The load capacities apply for the main direction of loading.

## Linear Sets with Super Linear Bushings **A**, closed, tandem, flanged, Type R1083

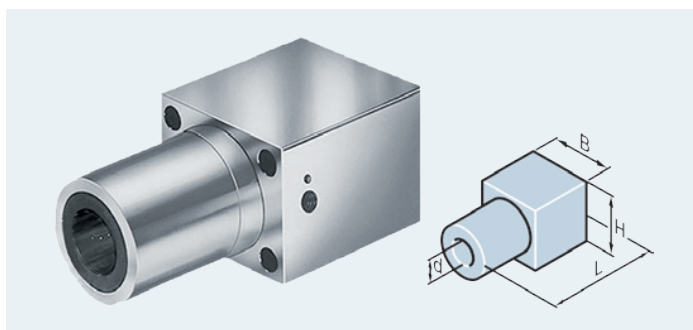

- ▶ Precision flanged housing, lightweight series (aluminum)
- ▶ Two Super Linear Bushings with self-alignment feature
- ▶ With two external seals
- ▶ With centering collar

### Features

- ▶ Fully sealed

### Product description

The Linear Sets are complete bearing units consisting of a housing with two Rexroth linear bushings. They are available in many different configurations. Because of their rationalized construction and fabrication, they offer users significant cost advantages over customer-built designs.

#### Detailed information:

Linear Bushings and Shafts R310EN 3100 catalog

### Technical data

Shaft diameter d	mm	12	16	20	25	30
C <sup>1)</sup>	N	1 350	1 660	3 280	6 420	7 800
C <sub>0</sub> <sup>1)</sup>	N	840	1 060	2 100	4 360	5 580
M <sub>L</sub>	Nm	26	35	84	205	289
M <sub>L0</sub>	Nm	16	22	54	140	206
H	mm	34	40	50	60	70
L	mm	76	84	104	130	152
B	mm	42	50	60	74	84
m	kg	0.20	0.32	0.55	1.00	1.50

<sup>1)</sup> Load capacity when both Linear Bushings are equally loaded.

## Linear Sets with Super Linear Bushings **A**, adjustable, cast iron housing, Type R1066

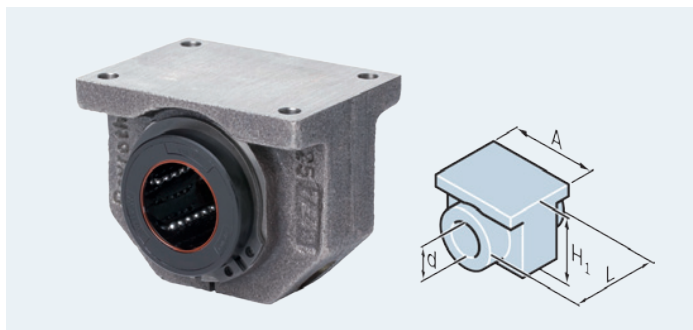

- ▶ Precision housing made of lamellar graphite cast iron
- ▶ Super Linear Bushing with self-alignment feature
- ▶ Radial clearance adjustable

### Features

- ▶ With integrated wiper seals

### Product description

The Linear Sets are complete bearing units consisting of a housing and a Rexroth linear bushing. They are available in many different configurations. Because of their rationalized construction and fabrication, they offer users significant cost advantages over customer-built designs.

### Detailed information:

Linear Bushings and Shafts R310EN 3100 catalog

### Technical data

Shaft diameter d	mm	20	30	40
C <sup>1)</sup>	N	2 470	5 860	10 070
C <sub>0</sub> <sup>1)</sup>	N	1 340	3 570	5 570
H <sub>1</sub>	mm	50	70	90
L	mm	45	68	80
A	mm	60	74	84
m	kg	0.41	1.19	2.26

<sup>1)</sup> The load capacities apply for the main direction of loading.

For ordering information for the GoTo products, see page 97.

Bosch Rexroth AG, R310EN 2060, 2013-09

## Linear Sets with Super Linear Bushings **A**, flanged, cast iron housing, Type R1081

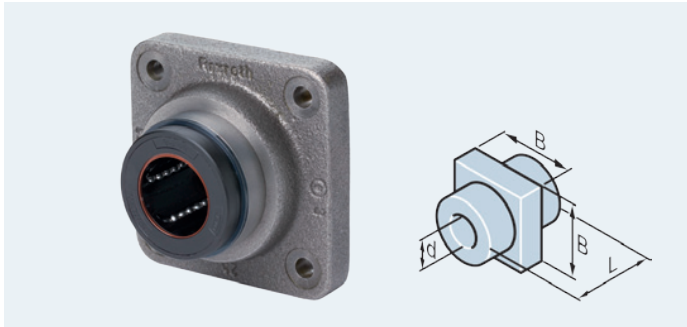

- ▶ Precision flanged housing made of lamellar graphite cast iron
- ▶ Super Linear Bushing with self-alignment feature
- ▶ With 2 integrated wiper seals

### Features

- ▶ Two retaining rings
- ▶ Two spacer rings (steel) for shaft diameters 16 to 40

### Product description

The Linear Sets are complete bearing units consisting of a housing and a Rexroth linear bushing. They are available in many different configurations. Because of their rationalized construction and fabrication, they offer users significant cost advantages over customer-built designs.

### Detailed information:

Linear Bushings and Shafts R310EN 3100 catalog

### Technical data

Shaft diameter d	mm	16	20	25	30	40	50
C	N	1 020	2 020	3 950	4 800	8 240	12 060
C <sub>0</sub>	N	530	1 050	2 180	2 790	4 350	6 470
B	mm	50	60	74	84	108	130
L	mm	36	45	58	68	80	100
m	kg	0.16	0.30	0.57	1.85	1.65	3.40

For ordering information for the GoTo products, see page 97.

## Super Linear Bushing **B**, closed, Type R0672

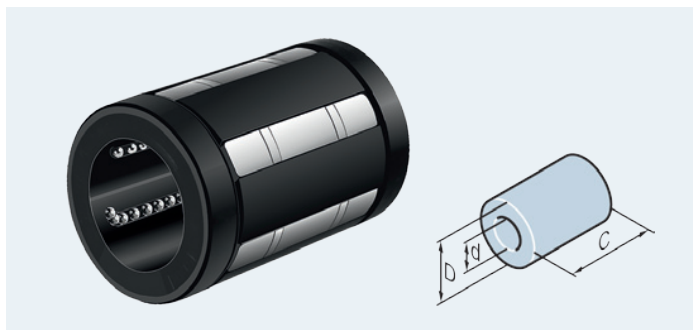

- ▶ High load-bearing capacity
- ▶ Smooth ball circulation
- ▶ Long service life
- ▶ Travel speed up to 3 m/s

### Features

- ▶ Hardened steel segmental load bearing plates with ground ball tracks
- ▶ Ball retainer and outer sleeve made of POM
- ▶ Balls made of anti-friction bearing steel
- ▶ With or without two integrated wiper seals

### Product description

The Super Linear Bushing **B** without self-alignment is the solution for applications where only one linear bushing is used per shaft and the linear bushing may not rock on the shaft.

### Detailed information:

Linear Bushings and Shafts R310EN 3100 catalog

### Technical data

Shaft diameter d	mm	10	12	16	20	25	30	40	50
$C_{max}$	N	820	1 140	1 400	2 470	4 820	5 860	10 070	14 730
$C_{0 max}$	N	480	620	780	1 340	2 790	3 570	5 570	8 280
$v_{max}^{1)}$	m/s	3	3	3	3	3	3	3	3
$a_{max}$	m/s <sup>2</sup>	150	150	150	150	150	150	150	150
D	mm	19	22	26	32	40	47	62	75
Length C	mm	29	32	36	45	58	68	80	100
m	kg	0.017	0.023	0.028	0.061	0.122	0.185	0.36	0.58

<sup>1)</sup> Up to 5 m/s possible (increased wear on the plastic parts).

For ordering information for the GoTo products, see page 97.

Bosch Rexroth AG, R310EN 2060, 2013-09

## Super Linear Bushing **H**, closed, Type R0732

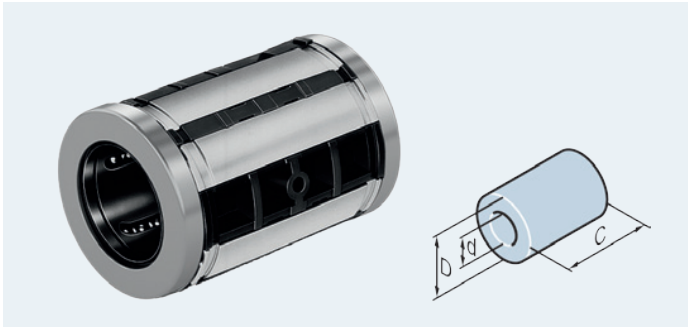

- ▶ High load-bearing capacity
- ▶ Highest precision
- ▶ Compensation of misalignments
- ▶ High travel speed up to 5 m/s

### Features

- ▶ Additional row of balls for higher load capacities
- ▶ Steel segmental load bearing plates with ground ball tracks and ground backs
- ▶ With or without integral wiper seals
- ▶ Two metal retaining rings
- ▶ Ball retainer made of POM

### Product description

The Super Linear Bushing **H** has even more load-bearing segmental steel plates and rows of balls than the well-known, tried and trusted Super Linear Bushing **A**. The higher load capacities permit even particularly heavy loads to be moved with full self-alignment.

### Detailed information:

Linear Bushings and Shafts R310EN 3100 catalog

### Technical data

Shaft diameter d	mm	20	25	30	40	50	60
C	N	2 520	4 430	6 300	9 680	16 000	23 500
C <sub>0</sub>	N	1 880	3 360	5 230	7 600	12 200	18 700
v <sub>max</sub>	m/s	5	5	5	5	5	5
a <sub>max</sub>	m/s <sup>2</sup>	150	150	150	150	150	150
D	mm	32	40	47	62	75	90
Length C	mm	45	58	68	80	100	125
m	kg	0.07	0.15	0.21	0.4	0.7	1.2

For ordering information for the GoTo products, see page 97.



## Super Linear Bushing **SH**, closed, Type R0730

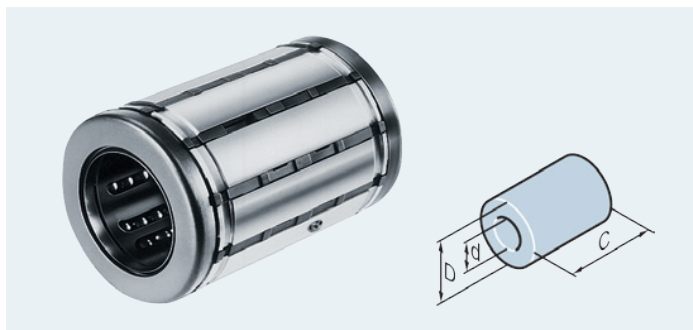

- ▶ Very high load capacity
- ▶ High rigidity
- ▶ Highest precision
- ▶ Compensation of misalignments
- ▶ High travel speed up to 5 m/s

### Features

- ▶ Additional steel segmental load bearing plates with ground ball tracks and ground backs.
- ▶ With or without integral wiper seals
- ▶ Two metal retaining rings
- ▶ Ball retainer made of POM

### Product description

The Super Linear Bushing **SH** has even more load-bearing segmental steel plates and rows of balls than the well-known, tried and trusted Super Linear Bushing **SA**. Very high load capacities permit even particularly heavy loads to be moved with full self-alignment.

### Detailed information:

Linear Bushings and Shafts R310EN 3100 catalog

### Technical data

Shaft diameter d	mm	20	25	30	40	50
C	N	3 530	6 190	6 300	13 500	22 300
C <sub>0</sub>	N	2 530	4 530	7 180	10 400	16 800
v <sub>max</sub>	m/s	5	5	5	5	5
a <sub>max</sub>	m/s <sup>2</sup>	150	150	150	150	150
D	mm	32	40	47	62	75
Length C	mm	45	58	68	80	100
m	kg	0.009	0.19	0.3	0.6	1.05

For ordering information for the GoTo products, see page 97.

Bosch Rexroth AG, R310EN 2060, 2013-09

## Standard Linear Bushings, closed, Type R0600 and R0602

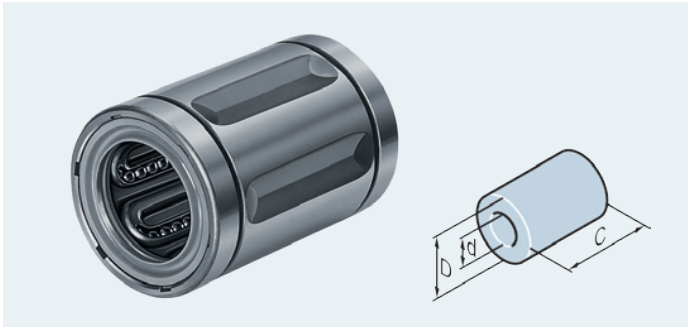

- ▶ Closed-type construction form for self-supporting shafts
- ▶ Steel ball retainer
- ▶ With two integrated wiper seals or integrated steel holding rings
- ▶ Shaft diameter 8 with plastic ball retainer

### Features

- ▶ Robust, hard-wearing design
- ▶ Particularly suitable for tough demands
- ▶ Size 12 and up can be used at temperatures up to 200 °C without seals
- ▶ Hardened and ground outer sleeves
- ▶ Antifriction bearing steel

### Product description

Linear Bushings in rugged all-metal design with steel ball retainer for harsh environments with heavy contamination. Many pockets acting as lubricant reservoirs for extended lubrication intervals or lubrication for life. Pockets also whisk away any dirt that may have worked its way in and so prevent jamming of the linear bushing.

### Detailed information:

Linear Bushings and Shafts R310EN 3100 catalog

### Technical data

Shaft diameter d	mm	8	12	16	20	25	30	40	50
$C_{max}$	N	370	480	670	1 390	2 480	2 980	5 480	8 740
$C_{0 max}$	N	330	400	620	1 250	2 280	2 860	4 880	8 280
$v_{max}$	m/s	2.5	2.5	2.5	2.5	2.5	2.5	2.5	2
$a_{max}$	m/s <sup>2</sup>	100	100	100	100	100	100	100	50
D	mm	16	22	26	32	40	47	62	75
Length C	mm	25	32	36	45	58	68	80	100
m	kg	0.02	0.04	0.05	0.10	0.19	0.32	0.62	1.14

For ordering information for the GoTo products, see page 97.

## Standard Linear Bushings, closed, corrosion-resistant, Type R0602

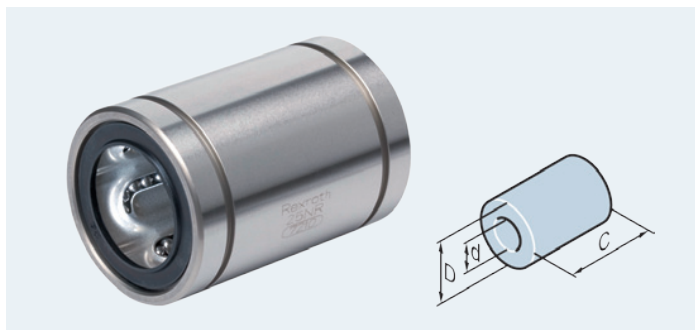

- ▶ Hardened and ground outer sleeve made of corrosion-resistant steel
- ▶ Corrosion-resistant steel ball retainer
- ▶ Balls made of corrosion-resistant steel
- ▶ Closed-type construction form for self-supporting shafts

### Features

- ▶ With two integrated wiper seals or integrated steel holding rings
- ▶ Robust, hard-wearing design
- ▶ Particularly suitable for tough demands
- ▶ Corrosion-resistant steels as per ISO 683-17/EN 10088

### Product description

Linear Bushings in rugged all-metal design with steel ball retainer for harsh environments with heavy contamination. Many pockets acting as lubricant reservoirs for extended lubrication intervals or lubrication for life. Pockets also whisk away any dirt that may have worked its way in and so prevent jamming of the linear bushing.

### Detailed information:

Linear Bushings and Shafts R310EN 3100 catalog

### Technical data

Shaft diameter d	mm	8	12	16	20	25
$C_{max}$	N	240	460	530	800	830
$C_{0\ max}$	N	330	600	630	1 250	2 100
$v_{max}$	m/s	2.5	2.5	2.5	2.5	2.5
$a_{max}$	m/s <sup>2</sup>	100	100	100	100	100
D	mm	16	22	26	32	40
Length C	mm	25	32	36	45	58
m	kg	0.022	0.045	0.060	0.100	0.235

For ordering information for the GoTo products, see page 98.

## Standard Linear Bushings, adjustable, Type R0610 and R0612

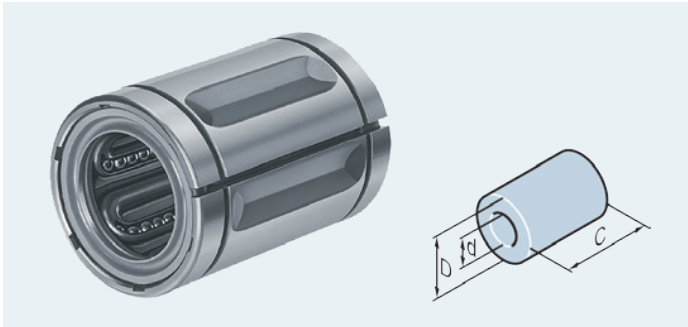

- ▶ Radial clearance adjustable
- ▶ Closed-type construction form for self-supporting shafts
- ▶ Steel ball retainer
- ▶ Shaft diameter 8 with plastic ball retainer
- ▶ With two integrated wiper seals or integrated steel holding rings

### Features

- ▶ Robust, hard-wearing design
- ▶ Particularly suitable for tough demands
- ▶ Size 12 and up can be used at temperatures up to 200 °C without seals
- ▶ Hardened and ground outer sleeves
- ▶ Antifriction bearing steel

### Product description

Linear Bushings in rugged all-metal design with steel ball retainer for harsh environments with heavy contamination. Many pockets acting as lubricant reservoirs for extended lubrication intervals or lubrication for life. Pockets also whisk away any dirt that may have worked its way in and so prevent jamming of the linear bushing.

#### Detailed information:

Linear Bushings and Shafts R310EN 3100 catalog

### Technical data

Shaft diameter d	mm	8	12	16	20	25	30	40	50
$C_{max}$	N	370	480	670	1 390	2 480	2 980	5 480	8 740
$C_{0 max}$	N	330	400	620	1 250	2 280	2 860	4 880	8 280
$v_{max}$	m/s	2.5	2.5	2.5	2.5	2.5	2.5	2.5	2
$a_{max}$	m/s <sup>2</sup>	100	100	100	100	100	100	100	50
D	mm	16	22	26	32	40	47	62	75
Length C	mm	25	32	36	45	58	68	80	100
m	kg	0.02	0.04	0.05	0.10	0.19	0.32	0.62	1.14

For ordering information for the GoTo products, see page 98.

## Linear Sets with Standard Linear Bushings, adjustable, cast iron housing, Type R1066

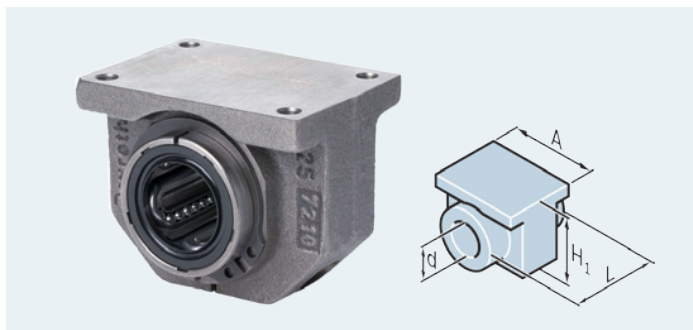

- ▶ Precision housing made of lamellar graphite cast iron
- ▶ Standard Linear Bushing
- ▶ Radial clearance adjustable

### Features

- ▶ With two integrated wiper seals
- ▶ With two retaining rings

### Product description

The Linear Sets are complete bearing units consisting of a housing and a Rexroth linear bushing. They are available in many different configurations. Because of their rationalized construction and fabrication, they offer users significant cost advantages over customer-built designs.

### Detailed information:

Linear Bushings and Shafts R310EN 3100 catalog

### Technical data

Shaft diameter d	mm	25	30	40	50
C <sup>1)</sup>	N	2 080	2 820	5 170	8 260
C <sub>0</sub> <sup>1)</sup>	N	1 560	2 230	3 810	6 470
H <sub>1</sub>	mm	60	70	90	105
L	mm	58	68	80	100
A	mm	74	84	108	130
m	kg	0.89	1.33	2.51	3.68

<sup>1)</sup> The load capacities stated are minimal values as the orientation and direction of load cannot always be precisely defined.

For ordering information for the GoTo products, see page 98.

Bosch Rexroth AG, R310EN 2060, 2013-09

## Linear Sets with Standard Linear Bushings, flanged, cast iron housing, Type R1081

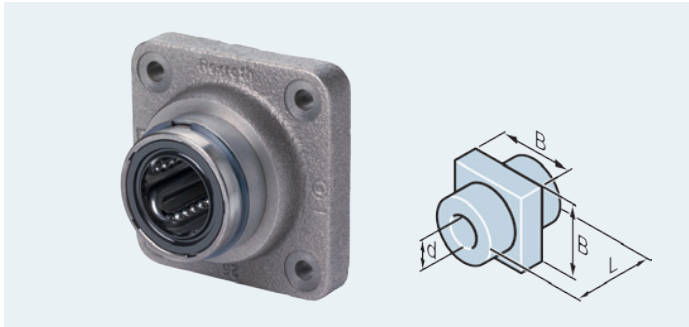

- ▶ Precision flanged housing made of lamellar graphite cast iron
- ▶ Standard Linear Bushing

### Features

- ▶ With two integrated wiper seals
- ▶ With two retaining rings
- ▶ With two spacer rings for shaft diameters 16 to 40

### Product description

The Linear Sets are complete bearing units consisting of a housing and a Rexroth linear bushing. They are available in many different configurations. Because of their rationalized construction and fabrication, they offer users significant cost advantages over customer-built designs.

### Detailed information:

Linear Bushings and Shafts R310EN 3100 catalog

### Technical data

Shaft diameter d	mm	16	20	25	30	40	50
C <sup>1)</sup>	N	580	1 170	2 080	2 820	5 170	8 260
C <sub>0</sub> <sup>1)</sup>	N	440	860	1 560	2 230	3 810	6 470
B	mm	50	60	74	84	108	130
L	mm	36	45	58	68	80	100
m	kg	0.18	0.33	0.63	1.00	1.90	4.00

<sup>1)</sup> The load capacities stated are minimal values as the orientation and direction of load cannot always be precisely defined.

## Segmental Linear Bushing, closed, normal or corrosion-resistant, Type R0668

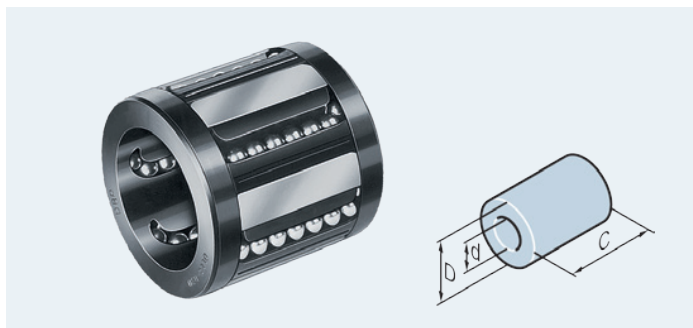

- ▶ Corrosion-resistant version available
- ▶ Multi-purpose
- ▶ Economical
- ▶ Travel speed up to 3 m/s

### Features

- ▶ Segmental load bearing plates made of hardened or corrosion-resistant steel
- ▶ Ball retainer made of polyamide

### Product description

The Segmental Linear Bushing with its durable plastic housing, is a cost-effective, ready-to-install Linear Bushing. For applications in corrosive conditions or where there are heavy requirements on cleanliness, such as in the food, semiconductor or medical equipment industries, this linear bushing is also available in a corrosion-resistant version.

### Detailed information:

Linear Bushings and Shafts R310EN 3100 catalog

### Technical data

Shaft diameter d	mm	12	16	20	25	30	40
$C_{max}$	N	570	860	1 080	1 730	2 530	4 100
$C_{max}$ corrosion-resistant	N	290	430	540	870	1 270	2 050
$C_{0\ max}$	N	620	910	1 120	1 750	2 510	4 180
$C_{0\ max}$ corrosion-resistant	N	490	730	890	1 400	2 000	3 340
$v_{max}$	m/s	3	3	3	3	3	3
$a_{max}$	m/s <sup>2</sup>	150	150	150	150	150	150
D	mm	20	25	30	37	44	56
Length C	mm	24	28	30	37	44	56
m	kg	0.013	0.02	0.031	0.057	0.096	0.17

For ordering information for the GoTo products, see page 99.

## Precision Steel Shafts, solid, Type R1000

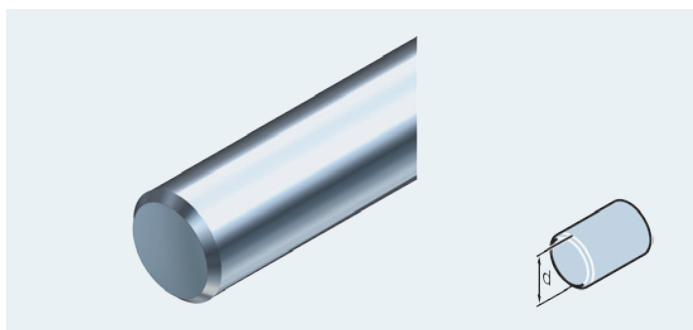

- ▶ Various diameters in tolerance class h6
- ▶ Heat-treated steel
- ▶ Corrosion-resistant steel
- ▶ Hard chrome plated

### Features

- ▶ With chamfers to protect the Linear Bushing seal
- ▶ Broad spectrum of uses (guide shaft, roller, etc.)

### Product description

Broad application spectrum with shafts made of heat-treated steel and corrosion-resistant steel as well as hard chrome plated. Precision steel shafts are induction hardened and smoothed by centerless grinding. They are cut to length and chamfered according to customer specifications.

### Detailed information:

Linear Bushings and Shafts R310EN 3100 catalog

### Technical data

Shaft diameter d	mm	8	10	12	16	20	25	30	40	50
Heat-treated steel		✓	✓	✓	✓	✓	✓	✓	✓	✓
Corrosion-resistant X46Cr13		✓	✓	✓	✓	✓	✓	✓	✓	✓
Corrosion-resistant X90CrMoV18						✓	✓	✓	✓	✓
Hard chrome plated							✓	✓	✓	✓
m	kg/m	0.39	0.61	0.88	1.57	2.45	3.83	5.51	9.80	15.32
L <sub>max</sub>	mm	5 900	5 900	5 900 <sup>1)</sup>	5 900	5 900	5 900	5 900	5 900	5 900

<sup>1)</sup> In the corrosion-resistant version X46Cr13, L<sub>max</sub> = 3 450 mm



## Precision Steel Shafts, tubular, Type R1001

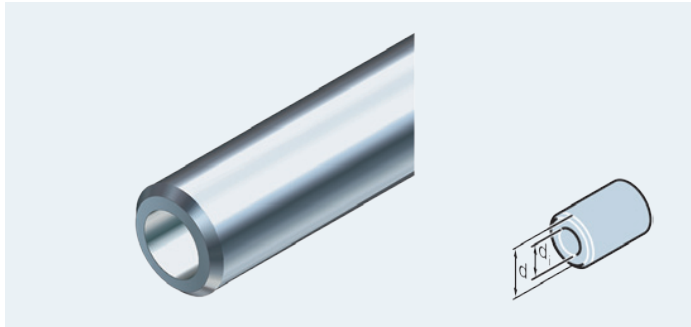

- ▶ Heat-treated steel in tolerance class h6
- ▶ Hard chrome plated in tolerance class h7

### Features

- ▶ With chamfers to protect the Linear Bushing seal
- ▶ Broad spectrum of uses (guide shaft, roller, etc.)

### Product description

Broad application spectrum with shafts in various tolerances made of heat-treated steel as well as hard chrome plated. Precision steel shafts are induction hardened and smoothed by centerless grinding. They are cut to length and chamfered according to customer specifications.

### Detailed information:

Linear Bushings and Shafts R310EN 3100 catalog

### Technical data

Shaft diameter d	mm	25	30	40	50
Heat-treated steel		✓	✓	✓	✓
Hard chrome plated			✓	✓	✓
d <sub>i</sub> (approx.)	mm	14	19	26.5	29.6
m	kg/m	2.63	3.30	5.50	9.95
L <sub>max</sub>	mm	5 800	5 800	5 800	5 800

For ordering information for the GoTo products, see page 99.

# Compact Shaft Support Blocks, aluminum

## Type R1058

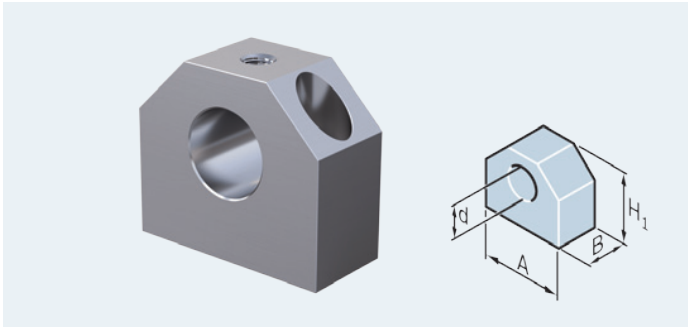

- ▶ Aluminum
- ▶ Precision machined
- ▶ Especially low profile
- ▶ Clamping from above for better access

### Features

- ▶ Thread for attachment from below
- ▶ Drill hole for attachment from above

### Product description

Compact Shaft Support Blocks are used to fix the ends of guide shafts carrying Compact Linear Bushings and Compact Linear Sets. Rexroth Compact Shaft Support Blocks provide significant technical and cost advantages over customer-built designs. They can be fastened from above or below and allow rigid fixing of the shaft.

### Detailed information:

Linear Bushings and Shafts R310EN 3100 catalog

### Technical data

Shaft diameter d	mm	12	16	20	25	30	40	50
H <sub>1</sub>	mm	33	38	45	54	60	76	92
B	mm	18	20	24	28	30	40	50
A	mm	40	45	53	62	67	87	103
m	kg	0.045	0.065	0.11	0.17	0.22	0.47	0.82

## Shaft Support Blocks, aluminum, Type R1057

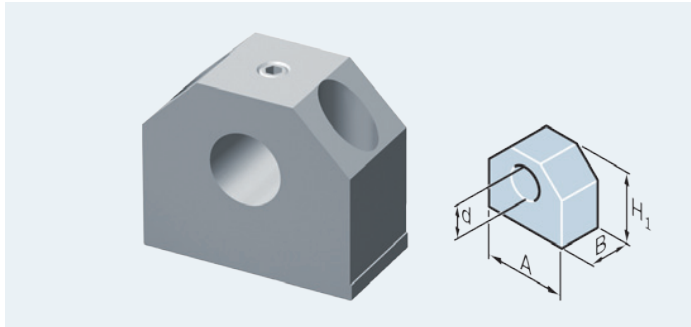

- ▶ Aluminum
- ▶ Rigid shaft mounting due to extra-wide design
- ▶ Clamping from above for better access
- ▶ Thread for attachment from below
- ▶ With reference edge for easy alignment

### Features

- ▶ Greater security through clamping screw with large thread diameter
- ▶ Drill hole for attachment from above
- ▶ High rigidity
- ▶ Interchangeability thanks to high dimensional accuracy
- ▶ Simple mounting

### Product description

Shaft support blocks are used to fix the ends of guide shafts with closed-type linear bushings and linear sets. Rexroth shaft support blocks provide significant technical and cost advantages over customer-built designs. Aluminum shaft support blocks have an extra-wide design, allowing rigid fixing of the shaft. They can also be fastened from above or below and aligned easily and precisely with the help of the reference edge.

### Detailed information:

Linear Bushings and Shafts R310EN 3100 catalog

### Technical data

Shaft diameter d	mm	10	12	16	20	25	30	40	50
H <sub>1</sub>	mm	31	35	42	51	61	70	88	105
B	mm	20	20	24	30	38	40	48	58
A	mm	40	43	53	60	78	87	108	132
m	kg	0.05	0.06	0.11	0.18	0.35	0.48	0.90	1.50

For ordering information for the GoTo products, see page 100.

# Ball Screw Assemblies

Ball screw assemblies are the efficient solution for precise conversion of rotary to linear motion. Building on long years of experience and deep engineering expertise, we have developed a product range that meets the most varied requirements. No matter whether you need very high linear speeds, maximum load ratings, or minimum installed length, you will always find the right solution in Rexroth's broad manufacturing spectrum. To make sure your application runs with utmost accuracy and operational safety, the individual components in our range have been precisely matched to one another. That makes it easy to put together complete assemblies quickly and efficiently.

## Ball Nuts

The flanged nuts from the standard series are available not only with Rexroth connection dimensions but also in a version with DIN connection dimensions. The corresponding engineering standards (DIN 69051 and ISO 3408) are therefore fully supported by Rexroth. Almost all single nuts in the version with axial backlash can be easily mounted on the screw by the customer – which is especially useful when it comes to replacements.

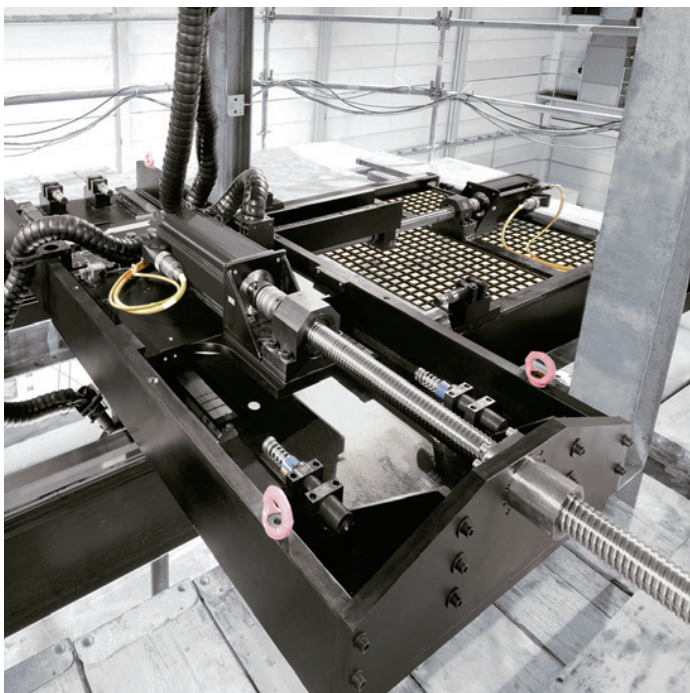

## Precision Screws

Precision-rolled screws from Rexroth are the core element of Rexroth Ball Screw Assemblies. They are produced in high quality in many different sizes and leads. Depending on the lead, Rexroth screws can also be delivered in two-start or four-start versions.

In combination with the multi-start Rexroth ball nuts, this allows higher load ratings to be achieved within a short overall length.

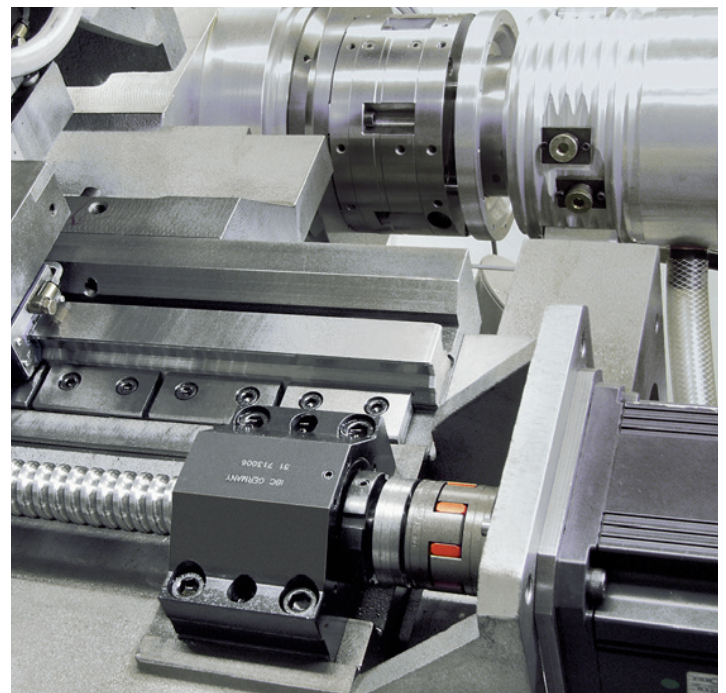

## Flanged Single Nuts FEM-E-C, standard, Type R1502

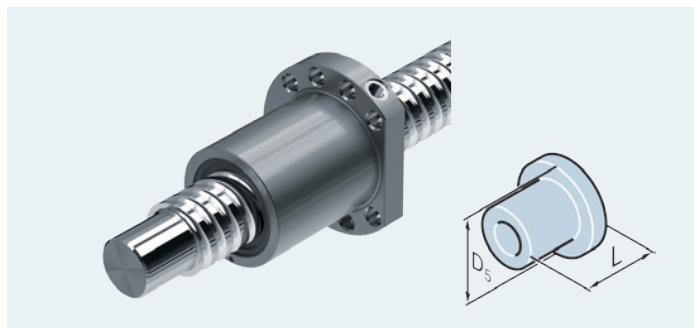

- ▶ Standard seals
- ▶ Connection dimensions per DIN 69051, Part 5
- ▶ With backlash
- ▶ Optional reinforced seals

### Features

- ▶ High axial load-bearing capacity
- ▶ High dynamic
- ▶ High rigidity
- ▶ For precision-rolled screws SN-R in tolerance grades T5, T7, T9

### Product description

Ball screw assemblies are the efficient solution for precise conversion of rotary to linear motion. Ball screw assemblies are used in applications requiring very high linear speeds, maximum load ratings, or minimum installation lengths.

### Detailed information:

Ball Screw Assemblies R310EN 3301 catalog

### Technical data

Size		16x5Rx3-4	16x10Rx3-3	16x16Rx3-3	20x5Rx3-4	20x20Rx3.5-3	25x5Rx3-4	25x10Rx3-4	25x25Rx3.5-3
C	N	12 300	9 600	9 300	14 300	13 300	15 900	15 700	14 700
D <sub>5</sub>	mm	48	48	48	58	58	62	62	62
L	mm	38	45	61	40	77	45	64	95
v <sub>max</sub>	m/s	30	60	96	30	120	30	60	150
m	kg	0.19	0.21	0.26	0.31	0.49	0.36	0.47	0.63
Size		32x5Rx3.5-4	32x10Rx3.969-5	32x20Rx3.969-3	32x32Rx3.969-3	40x5Rx3.5-5	40x10Rx6-4	40x20Rx6-3	
C	N	21 600	31 700	19 700	19 500	29 100	50 000	37 900	
D <sub>5</sub>	mm	80	80	80	80	93	93	93	
L	mm	48	77	84	120	54	70	88	
v <sub>max</sub>	m/s	23	47	94	150	19	38	75	
m	kg	0.62	0.84	0.9	1.21	1.03	1.19	1.44	

For ordering information for the GoTo products, see page 100.

Bosch Rexroth AG, R310EN 2060, 2013-09

## Flanged Single Nuts FEM-E-S, standard, Type R1512, size 16x5 to 25x5

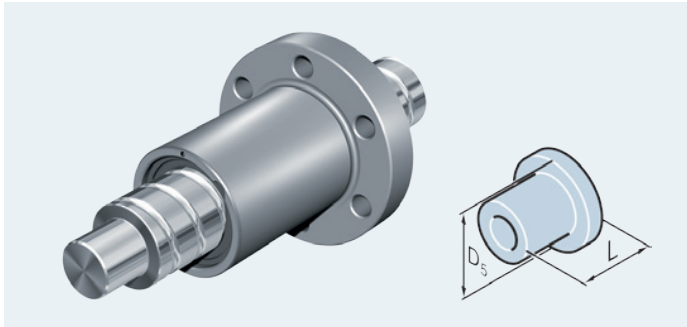

- ▶ Standard seals
- ▶ Rexroth connection dimensions
- ▶ With backlash
- ▶ Optional reinforced seals

### Features

- ▶ High axial load-bearing capacity
- ▶ High dynamic
- ▶ High rigidity
- ▶ For precision-rolled screws SN-R in tolerance grades T5, T7, T9

### Product description

Ball screw assemblies are the efficient solution for precise conversion of rotary to linear motion. Ball screw assemblies are used in applications requiring very high linear speeds, maximum load ratings, or minimum installation lengths.

### Detailed information:

Ball Screw Assemblies R310EN 3301 catalog

### Technical data

Size		8x2.5Rx1.588-3	12x5Rx2-3	16x5Rx3-4	16x10Rx3-3	16x16Rx3-2
C	N	2 200	3 800	12 300	9 600	6 300
D <sub>s</sub>	mm	30	40	53	53	58
L	mm	16	28	38	45	45
v <sub>max</sub>	m/s	15	30	30	60	96
m	kg	0.05	0.12	0.24	0.25	0.39
Size		20x5Rx3-4	20x10Rx3-4	20x20Rx3.5-2	25x5Rx3-4	
C	N	14 300	14 100	9 100	15 900	
D <sub>s</sub>	mm	58	58	63	63	
L	mm	40	60	60	45	
v <sub>max</sub>	m/s	30	60	120	30	
m	kg	0.28	0.36	0.6	0.35	

For ordering information for the GoTo products, see page 100.

## Flanged Single Nuts FEM-E-S, standard, Type R1512, size 25x10 to 40x40

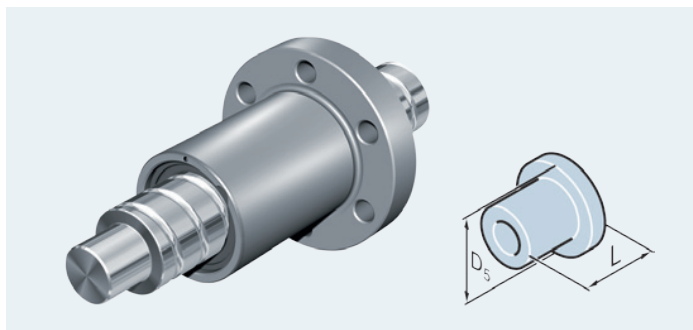

- ▶ Standard seals
- ▶ Rexroth connection dimensions
- ▶ With backlash
- ▶ Optional reinforced seals

### Features

- ▶ High axial load-bearing capacity
- ▶ High dynamic
- ▶ High rigidity
- ▶ For precision-rolled screws SN-R in tolerance grades T5, T7, T9

### Product description

Ball screw assemblies are the efficient solution for precise conversion of rotary to linear motion. Ball screw assemblies are used in applications requiring very high linear speeds, maximum load ratings, or minimum installation lengths.

### Detailed information:

Ball Screw Assemblies R310EN 3301 catalog

### Technical data

Size		25x10Rx3-4	25x25Rx3.5-2	32x5Rx3.5-4	32x10Rx3.969-5	32x20Rx3.969-2
C	N	15 700	10 100	21 600	31 700	13 500
D <sub>5</sub>	mm	63	73	73	73	80
L	mm	64	70	48	77	64
v <sub>max</sub>	m/s	60	150	23	47	94
m	kg	0.44	1.09	0.54	0.72	1.02
Size		32x32Rx3.969-2	40x5Rx3.5-5	40x10Rx6-4	40x20Rx6-3	40x40Rx6-2
C	N	13 400	29 100	50 000	37 900	25 500
D <sub>5</sub>	mm	80	80	95	95	110
L	mm	88	54	70	88	102
v <sub>max</sub>	m/s	150	19	38	75	150
m	kg	1.4	0.71	1.29	1.54	3.59

For ordering information for the GoTo products, see page 100.



# Precision-Rolled Screws SN-R, Type R1511

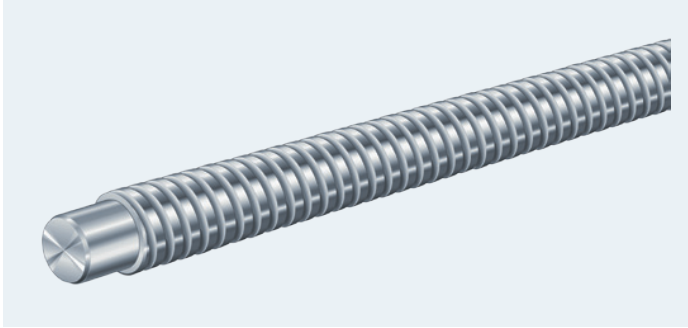

► Rolled screw

## Features

- Tolerance grades T5, T7, T9

## Product description

Precision screws are produced in high quality in many different sizes and leads. Depending on the lead, screws can also be delivered in two-start or four-start versions. In combination with our multi-start ball nuts, this allows higher load ratings to be achieved within a short overall length.

### Detailed information:

Ball Screw Assemblies R310EN 3301 catalog

## Technical data

Size		8x2.5Rx1.588	12x5Rx2	16x5Rx3	16x10Rx3	16x16Rx3	20x5Rx3	20x20Rx3.5
$J_s$	kgcm <sup>2</sup> /m	0.04	0.11	0.31	0.31	0.34	0.84	0.81
m	kg/m	0.30	0.75	1.24	1.23	1.29	2.03	1.99
$L_{max}$	mm			1 500	1 500	1 500	1 500	1 500
Size		25x5Rx3	25x10Rx3	25x25Rx3.5	32x5Rx3.5	32x10Rx3.969	32x20Rx3.969	32x32Rx3.969
$J_s$	kgcm <sup>2</sup> /m	2.22	2.39	2.15	6.05	6.4	6.39	6.17
m	kg/m	3.31	3.43	3.25	5.45	5.6	5.6	5.5
$L_{max}$	mm	2 500	2 500	2 500	2 500	2 500	2 500	2 500
Size		40x5Rx3.5	40x10Rx6	40x20Rx6	40x40Rx6			
$J_s$	kgcm <sup>2</sup> /m	15.64	13.55	13.52	13.42			
m	kg/m	8.78	8.15	8.14	8.11			
$L_{max}$	mm	4 500	4 500	4 500	4 500			

For ordering information for the GoTo products, see page 101.





# Linear Systems

Rexroth Linear Systems range from single axes to sophisticated, pre-configured complete solutions precisely engineered to meet your specific requirements and application needs – compact and ready to install. They help you to get ahead faster, more easily and much more efficiently.

## Electromechanical Cylinder in fixed length increments

The Electromechanical Cylinder EMC from Rexroth is a powerful alternative to pneumatic cylinders while providing significant benefits in terms of energy efficiency, a prime goal in engineering today. It also offers clear conceptual advantages, allowing travel to any intermediate target position as well as creating greater flexibility through higher thrust and variable speeds.

Whether installed with articulated bearings (to avoid the effects of transverse forces) or rigid mounts, this product is

especially well suited for typical motion applications, including handling tasks.

EMCs with fixed length increments have faster delivery times than EMCs with freely configurable lengths. The faster delivery times apply only to the fixed-length EMC without attachments. For more information on the fixed length increments, please refer to our online catalog at [www.boschrexroth.com/eshop](http://www.boschrexroth.com/eshop).

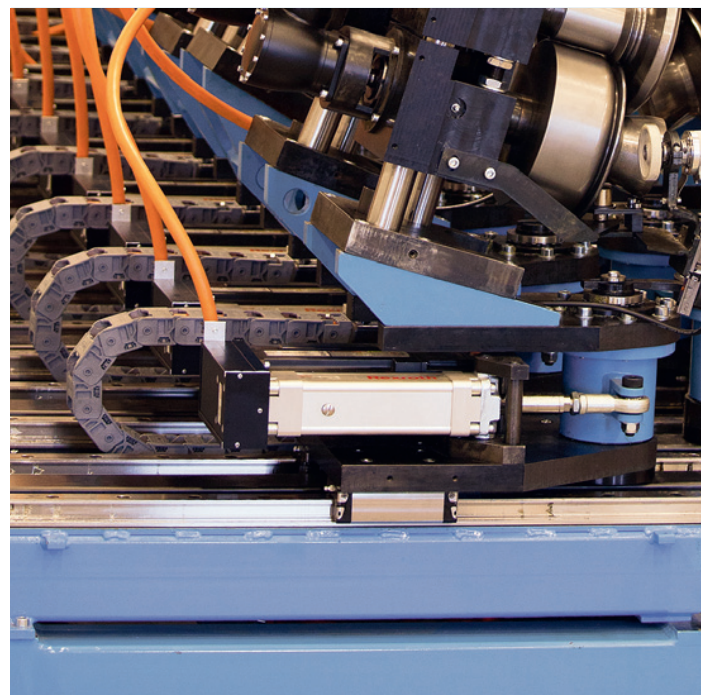
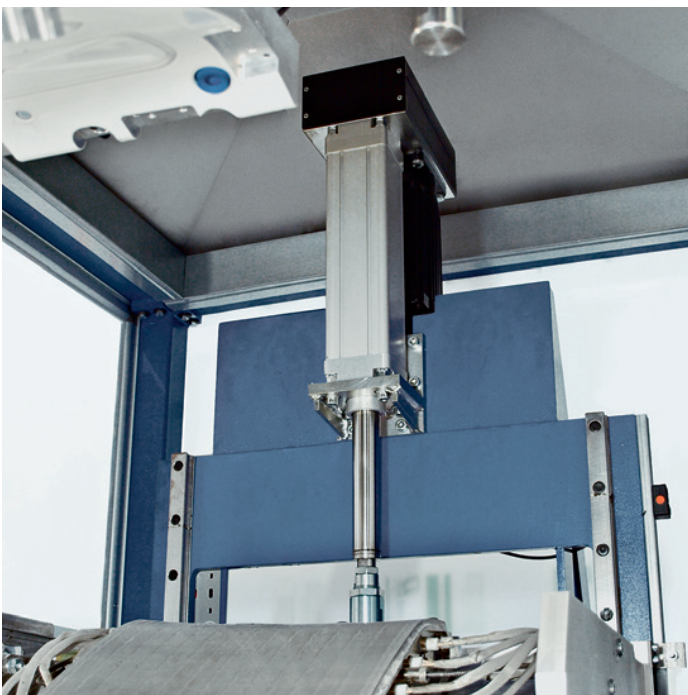

## Electromechanical Cylinders, fixed length, Type 1560, size 32 to 50

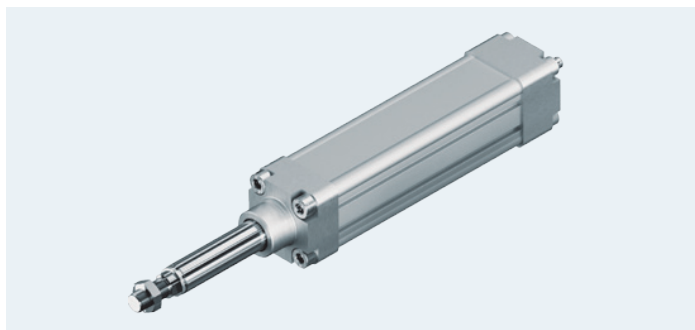

- ▶ High energy efficiency compared with fluid-driven designs or trapezoidal screws
- ▶ Integrated ball screw drive ensures exact positioning and powerful thrust capability
- ▶ Compact construction

### Features

- ▶ Large range of size increments
- ▶ Piston rod made of corrosion-resistant stainless steel
- ▶ Rapid installation, compatible with other products from Rexroth
- ▶ Ball screw with reduced backlash and tolerance grade 7

### Product description

Mechanics with proven, precision ball screws in all common diameter/lead combinations. Performance characteristics such as positioning accuracy, thrust or speed can be optimized to meet the requirements of each specific application. Through the use of generously sized angular-contact thrust ball bearings, the load rating is used to its maximum potential.

### Detailed information:

Electromechanical Cylinders EMC R310EN 3306 catalog

### Technical data

Size		32	32	40	40	40	50	50
<b>Ball screw d<sub>0</sub>xP</b>	mm	<b>12x5</b>	<b>12x10</b>	<b>16x5</b>	<b>16x10</b>	<b>16x16</b>	<b>20x5</b>	<b>20x20</b>
C <sub>EMC</sub> <sup>1)</sup>	N	3 800	2 500	12 300	9 600	9 600	14 300	13 300
F <sub>max EMC</sub> <sup>2)</sup>	N	580	440	2 800	2 200	1 700	5 800	3 100
M <sub>P</sub> <sup>2)</sup>	Nm	0.51	0.78	2.46	3.95	4.87	5.09	11.08
v <sub>max</sub>	m/s	0.57	1.13	0.38	0.77	1.23	0.32	1.27
s <sub>max</sub> (fixed length)	mm	100	100	100	100	200	100	200
		200	200	200	200	—	200	—
		—	—	320	320	—	400	—
		—	—	400	400	—	—	—

<sup>1)</sup> With respect to the desired service life, equivalent dynamic loads of up to 20% of the load rating have generally proved acceptable.

<sup>2)</sup> The attainable values may vary according to the version, mounting orientation and maximum travel.

For ordering information for the GoTo products, see page 102.

Bosch Rexroth AG, R310EN 2060, 2013-09

## Electromechanical Cylinders, fixed length, Type 1560, size 63 to 100

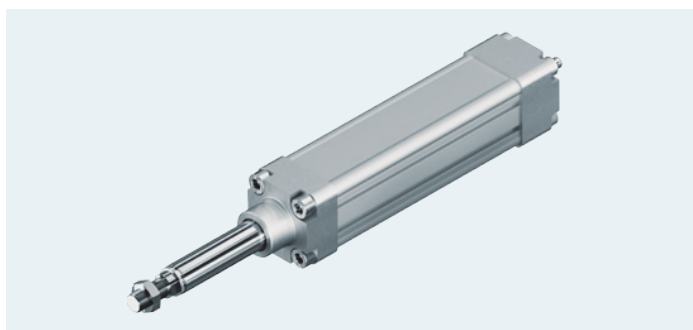

- ▶ High energy efficiency compared with fluid-driven designs or trapezoidal screws
- ▶ Integrated ball screw drive ensures exact positioning and powerful thrust capability
- ▶ Compact construction

### Features

- ▶ Large range of size increments
- ▶ Piston rod made of corrosion-resistant stainless steel
- ▶ Rapid installation, compatible with other products from Rexroth
- ▶ Ball screw with reduced backlash and tolerance grade 7

### Product description

Mechanics with proven, precision ball screws in all common diameter/lead combinations. Performance characteristics such as positioning accuracy, thrust or speed can be optimized to meet the requirements of each specific application. Through the use of generously sized angular-contact thrust ball bearings, the load rating is used to its maximum potential.

### Detailed information:

Electromechanical Cylinders EMC R310EN 3306 catalog

### Technical data

Size		63	63	80	80	100	100
Ball screw $d_0 \times P$	mm	25x5	25x10	32x5	32x10	40x5	40x20
$C_{EMC}^{1)}$	N	15 900	15 700	21 600	26 000	29 000	29 000
$F_{max EMC}^{2)}$	N	15 900	15 700	19 100	17 400	29 000	29 000
$M_p^{2)}$	Nm	14.06	27.76	16.89	30.75	25.64	102.57
$v_{max}$	m/s	0.28	0.55	0.25	0.50	0.18	0.73
$s_{max}$ (fixed length)	mm	100	200	100	200	200	400
		200	400	200	400	–	–
		400	–	–	–	–	–

<sup>1)</sup> With respect to the desired service life, equivalent dynamic loads of up to 20% of the load rating have generally proved acceptable.

<sup>2)</sup> The attainable values may vary according to the version, mounting orientation and maximum travel.



# Ordering Information

The following pages list all available GoTo products with their description and part number. In addition, the table provides the maximum order quantity and the delivery time.

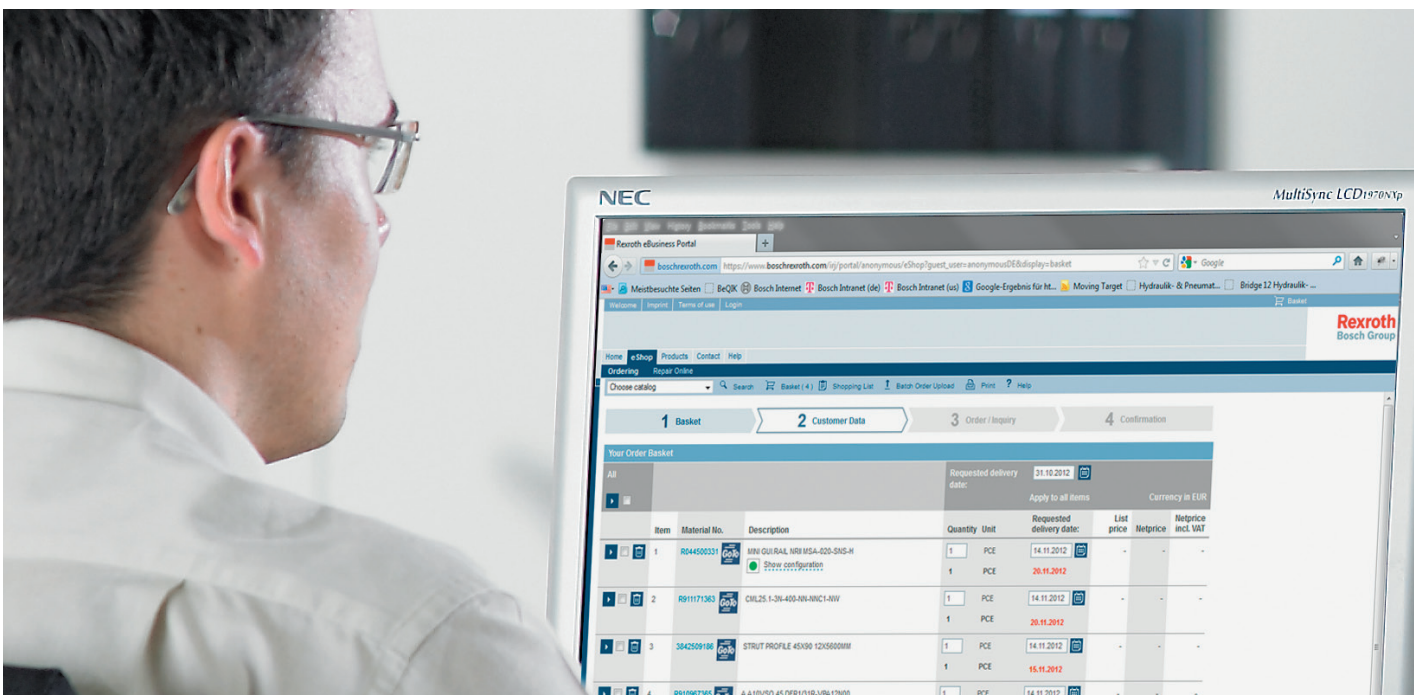

Page	Part number	Size	Description	Specification	Maximum GoTo quantity (units)	Delivery time (working days) ex works in Germany
<b>Roller Rail Systems</b>						
8	<b>Standard Roller Runner Blocks, steel, FNS, Type R1851</b>					
	R185122210	25	RWA-025-FNS-C2-P-2	P class, preload C2	12	5
	R185123210	25	RWA-025-FNS-C3-P-2	P class, preload C3	12	5
	R18513222X	35	RWD-035-FNS-C2-P-2	P class, preload C2	4	5
	R18513322X	35	RWD-035-FNS-C3-P-2	P class, preload C3	4	5
	R18514222X	45	RWD-045-FNS-C2-P-2	P class, preload C2	4	5
	R18514322X	45	RWD-045-FNS-C3-P-2	P class, preload C3	4	5
9	<b>Standard Roller Runner Blocks, steel, FLS, Type R1853</b>					
	R185322210	25	RWA-025-FLS-C2-P-2	P class, preload C2	12	5
	R185323210	25	RWA-025-FLS-C3-P-2	P class, preload C3	12	5
	R18533222X	35	RWD-035-FLS-C2-P-2	P class, preload C2	4	5
	R18533322X	35	RWD-035-FLS-C3-P-2	P class, preload C3	4	5
	R18534222X	45	RWD-045-FLS-C2-P-2	P class, preload C2	4	5
	R18534322X	45	RWD-045-FLS-C3-P-2	P class, preload C3	4	5
10	<b>Standard Roller Runner Blocks, steel, SNH, Type R1821</b>					
	R182122210	25	RWA-025-SNH-C2-P-2	P class, preload C2	12	5
	R182123210	25	RWA-025-SNH-C3-P-2	P class, preload C3	12	5
	R18213222X	35	RWD-035-SNH-C2-P-2	P class, preload C2	4	5
	R18213322X	35	RWD-035-SNH-C3-P-2	P class, preload C3	4	5
	R18214222X	45	RWD-045-SNH-C2-P-2	P class, preload C2	4	5
	R18214322X	45	RWD-045-SNH-C3-P-2	P class, preload C3	4	5
11	<b>Standard Roller Runner Blocks, steel, SLH, Type R1824</b>					
	R182422210	25	RWA-025-SLH-C2-P-2	P class, preload C2	12	5
	R182423210	25	RWA-025-SLH-C3-P-2	P class, preload C3	12	5
	R18243222X	35	RWD-035-SLH-C2-P-2	P class, preload C2	4	5
	R18243322X	35	RWD-035-SLH-C3-P-2	P class, preload C3	4	5
	R18244222X	45	RWD-045-SLH-C2-P-2	P class, preload C2	4	5
	R18244322X	45	RWD-045-SLH-C3-P-2	P class, preload C3	4	5
12	<b>Standard Roller Guide Rails, steel, SNS, Type R1805, with cover strip and protective end caps</b>					
	R180526231	25	RSA-025-SNS-P-B03-M1	P class	6	5
	R180536261	35	RSA-035-SNS-P-B03-M1	P class	6	5
	R180546261	45	RSA-045-SNS-P-B03-M1	P class	6	5
13	<b>Standard Roller Guide Rails, steel, SNS, Type R1807, for mounting from below</b>					
	R180720231	25	RSA-025-SNS-P-B08-M1	P class	6	5
	R180730231	35	RSA-035-SNS-P-B08-M1	P class	6	5
	R180740231	45	RSA-045-SNS-P-B08-M1	P class	6	5



Page	Part number	Size	Description	Specification	Maximum GoTo quantity (units)	Delivery time (working days) ex works in Germany
<b>Ball Rail Systems</b>						
16	<b>Standard Ball Runner Blocks, steel, FNS, Type R1651</b>					
	R165111220	15	KWD-015-FNS-C1-P-1	P class, preload C1	12	5
	R165111322	15	KWD-015-FNS-C1-H-1	H class, preload C1	4	5
	R165111422	15	KWD-015-FNS-C1-N-1	N class, preload C1	4	5
	R165112220	15	KWD-015-FNS-C2-P-1	P class, preload C2	12	5
	R165112320	15	KWD-015-FNS-C2-H-1	H class, preload C2	12	5
	R165112420	15	KWD-015-FNS-C2-N-1	N class, preload C2	12	5
	R165119420	15	KWD-015-FNS-C0-N-1	N class, without preload	12	5
	R165181220	20	KWD-020-FNS-C1-P-1	P class, preload C1	12	5
	R165181322	20	KWD-020-FNS-C1-H-1	H class, preload C1	4	5
	R165181422	20	KWD-020-FNS-C1-N-1	N class, preload C1	4	5
	R165182220	20	KWD-020-FNS-C2-P-1	P class, preload C2	12	5
	R165182320	20	KWD-020-FNS-C2-H-1	H class, preload C2	12	5
	R165189420	20	KWD-020-FNS-C0-N-1	N class, without preload	12	5
	R165121220	25	KWD-025-FNS-C1-P-1	P class, preload C1	12	5
	R165121322	25	KWD-025-FNS-C1-H-1	H class, preload C1	4	5
	R165121422	25	KWD-025-FNS-C1-N-1	N class, preload C1	4	5
	R165122220	25	KWD-025-FNS-C2-P-1	P class, preload C2	12	5
	R165122320	25	KWD-025-FNS-C2-H-1	H class, preload C2	12	5
	R165129420	25	KWD-025-FNS-C0-N-1	N class, without preload	12	5
	R165171220	30	KWD-030-FNS-C1-P-1	P class, preload C1	12	5
	R165171322	30	KWD-030-FNS-C1-H-1	H class, preload C1	4	5
	R165171422	30	KWD-030-FNS-C1-N-1	N class, preload C1	4	5
	R165172220	30	KWD-030-FNS-C2-P-1	P class, preload C2	12	5
	R165172320	30	KWD-030-FNS-C2-H-1	H class, preload C2	12	5
	R165179420	30	KWD-030-FNS-C0-N-1	N class, without preload	12	5
	R165131220	35	KWD-035-FNS-C1-P-1	P class, preload C1	12	5
	R165131322	35	KWD-035-FNS-C1-H-1	H class, preload C1	4	5
	R165131422	35	KWD-035-FNS-C1-N-1	N class, preload C1	4	5
	R165132220	35	KWD-035-FNS-C2-P-1	P class, preload C2	12	5
	R165132320	35	KWD-035-FNS-C2-H-1	H class, preload C2	12	5
	R165139420	35	KWD-035-FNS-C0-N-1	N class, preload C2	12	5
	R165141220	45	KWD-045-FNS-C1-P-1	P class, preload C1	12	5
	R165141320	45	KWD-045-FNS-C1-H-1	H class, preload C1	12	5
	R165141420	45	KWD-045-FNS-C1-N-1	N class, preload C1	12	5
	R165142220	45	KWD-045-FNS-C2-P-1	P class, preload C2	12	5
	R165142320	45	KWD-045-FNS-C2-H-1	H class, preload C2	12	5
	R165149420	45	KWD-045-FNS-C0-N-1	N class, without preload	12	5
17	<b>Standard Ball Runner Blocks, steel, FLS, Type R1653</b>					
	R165311220	15	KWD-015-FLS-C1-P-1	P class, preload C1	12	5
	R165311320	15	KWD-015-FLS-C1-H-1	H class, preload C1	12	5
	R165311420	15	KWD-015-FLS-C1-N-1	N class, preload C1	12	5
	R165312220	15	KWD-015-FLS-C2-P-1	P class, preload C2	12	5
	R165312320	15	KWD-015-FLS-C2-H-1	H class, preload C2	12	5



Page	Part number	Size	Description	Specification	Maximum GoTo quantity (units)	Delivery time (working days) ex works in Germany
	R165319420	15	KWD-015-FLS-C0-N-1	N class, without preload	12	5
	R165381220	20	KWD-020-FLS-C1-P-1	P class, preload C1	12	5
	R165381320	20	KWD-020-FLS-C1-H-1	H class, preload C1	12	5
	R165381420	20	KWD-020-FLS-C1-N-1	N class, preload C1	12	5
	R165382220	20	KWD-020-FLS-C2-P-1	P class, preload C2	12	5
	R165382320	20	KWD-020-FLS-C2-H-1	H class, preload C2	12	5
	R165389420	20	KWD-020-FLS-C0-N-1	N class, without preload	12	5
	R165321220	25	KWD-025-FLS-C1-P-1	P class, preload C1	12	5
	R165321320	25	KWD-025-FLS-C1-H-1	H class, preload C1	12	5
	R165321420	25	KWD-025-FLS-C1-N-1	N class, preload C1	12	5
	R165322220	25	KWD-025-FLS-C2-P-1	P class, preload C2	12	5
	R165322320	25	KWD-025-FLS-C2-H-1	H class, preload C2	12	5
	R165329420	25	KWD-025-FLS-C0-N-1	N class, without preload	12	5
	R165371220	30	KWD-030-FLS-C1-P-1	P class, preload C1	12	5
	R165371320	30	KWD-030-FLS-C1-H-1	H class, preload C1	12	5
	R165371420	30	KWD-030-FLS-C1-N-1	N class, preload C1	12	5
	R165372220	30	KWD-030-FLS-C2-P-1	P class, preload C2	12	5
	R165372320	30	KWD-030-FLS-C2-H-1	P class, preload C1	12	5
	R165379420	30	KWD-030-FLS-C0-N-1	N class, without preload	12	5
	R165331220	35	KWD-035-FLS-C1-P-1	P class, preload C1	12	5
	R165331320	35	KWD-035-FLS-C1-H-1	H class, preload C1	12	5
	R165331420	35	KWD-035-FLS-C1-N-1	N class, preload C1	12	5
	R165332220	35	KWD-035-FLS-C2-P-1	P class, preload C2	12	5
	R165332320	35	KWD-035-FLS-C2-H-1	H class, preload C2	12	5
	R165339420	35	KWD-035-FLS-C0-N-1	N class, without preload	12	5
	R165341220	45	KWD-045-FLS-C1-P-1	P class, preload C1	12	5
	R165341320	45	KWD-045-FLS-C1-H-1	H class, preload C1	12	5
	R165341420	45	KWD-045-FLS-C1-N-1	N class, preload C1	12	5
	R165342220	45	KWD-045-FLS-C2-P-1	P class, preload C2	12	5
	R165342320	45	KWD-045-FLS-C2-H-1	H class, preload C2	12	5
	R165349420	45	KWD-045-FLS-C0-N-1	N class, without preload	12	5
18	<b>Standard Ball Runner Blocks, steel, FKS, Type R1665</b>					
	R166511320	15	KWD-015-FKS-C1-H-1	H class, preload C1	12	5
	R166511420	15	KWD-015-FKS-C1-N-1	N class, preload C1	12	5
	R166519420	15	KWD-015-FKS-C0-N-1	N class, without preload	12	5
	R166581320	20	KWD-020-FKS-C1-H-1	H class, preload C1	12	5
	R166581420	20	KWD-020-FKS-C1-N-1	N class, preload C1	12	5
	R166589420	20	KWD-020-FKS-C0-N-1	N class, without preload	12	5
	R166521320	25	KWD-025-FKS-C1-H-1	H class, preload C1	12	5
	R166521420	25	KWD-025-FKS-C1-N-1	N class, preload C1	12	5
	R166529420	25	KWD-025-FKS-C0-N-1	N class, without preload	12	5
	R166571320	30	KWD-030-FKS-C1-H-1	H class, preload C1	12	5
	R166571420	30	KWD-030-FKS-C1-N-1	N class, preload C1	12	5
	R166579420	30	KWD-030-FKS-C0-N-1	N class, without preload	12	5
	R166531320	35	KWD-035-FKS-C1-H-1	H class, preload C1	12	5
	R166531420	35	KWD-035-FKS-C1-N-1	N class, preload C1	12	5

Page	Part number	Size	Description	Specification	Maximum GoTo quantity (units)	Delivery time (working days) ex works in Germany
	R166539420	35	KWD-035-FKS-C0-N-1	N class, without preload	12	5
19	<b>Standard Ball Runner Blocks, steel, SNS, Type R1622</b>					
	R162211220	15	KWD-015-SNS-C1-P-1	P class, preload C1	12	5
	R162211322	15	KWD-015-SNS-C1-H-1	H class, preload C1	4	5
	R162211422	15	KWD-015-SNS-C1-N-1	N class, preload C1	4	5
	R162212220	15	KWD-015-SNS-C2-P-1	P class, preload C2	12	5
	R162212320	15	KWD-015-SNS-C2-H-1	H class, preload C2	12	5
	R162219420	15	KWD-015-SNS-C0-N-1	N class, without preload	12	5
	R162281220	20	KWD-020-SNS-C1-P-1	P class, preload C1	12	5
	R162281322	20	KWD-020-SNS-C1-H-1	H class, preload C1	4	5
	R162281422	20	KWD-020-SNS-C1-N-1	N class, preload C1	4	5
	R162282220	20	KWD-020-SNS-C2-P-1	P class, preload C2	12	5
	R162282320	20	KWD-020-SNS-C2-H-1	H class, preload C2	12	5
	R162289420	20	KWD-020-SNS-C0-N-1	N class, without preload	12	5
	R162221220	25	KWD-025-SNS-C1-P-1	P class, preload C1	12	5
	R162221322	25	KWD-025-SNS-C1-H-1	H class, preload C1	4	5
	R162221422	25	KWD-025-SNS-C1-N-1	N class, preload C1	4	5
	R162222220	25	KWD-025-SNS-C2-P-1	P class, preload C2	12	5
	R162222320	25	KWD-025-SNS-C2-H-1	H class, preload C2	12	5
	R162229420	25	KWD-025-SNS-C0-N-1	N class, without preload	12	5
	R162271220	30	KWD-030-SNS-C1-P-1	P class, preload C1	12	5
	R162271322	30	KWD-030-SNS-C1-H-1	H class, preload C1	4	5
	R162271422	30	KWD-030-SNS-C1-N-1	N class, preload C1	4	5
	R162272220	30	KWD-030-SNS-C2-P-1	P class, preload C2	12	5
	R162272320	30	KWD-030-SNS-C2-H-1	H class, preload C2	12	5
	R162279420	30	KWD-030-SNS-C0-N-1	N class, without preload	12	5
	R162231220	35	KWD-035-SNS-C1-P-1	P class, preload C1	12	5
	R162231322	35	KWD-035-SNS-C1-H-1	H class, preload C1	4	5
	R162231422	35	KWD-035-SNS-C1-N-1	N class, preload C1	4	5
	R162232220	35	KWD-035-SNS-C2-P-1	P class, preload C2	12	5
	R162232320	35	KWD-035-SNS-C2-H-1	H class, preload C2	12	5
	R162239420	35	KWD-035-SNS-C0-N-1	N class, without preload	12	5
	R162241220	45	KWD-045-SNS-C1-P-1	P class, preload C1	12	5
	R162241320	45	KWD-045-SNS-C1-H-1	H class, preload C1	12	5
	R162241420	45	KWD-045-SNS-C1-N-1	N class, preload C1	12	5
	R162242220	45	KWD-045-SNS-C2-P-1	P class, preload C2	12	5
	R162242320	45	KWD-045-SNS-C2-H-1	H class, preload C2	12	5
	R162249420	45	KWD-045-SNS-C0-N-1	N class, without preload	12	5
20	<b>Standard Ball Runner Blocks, steel, SLS, Type R1623</b>					
	R162311220	15	KWD-015-SLS-C1-P-1	P class, preload C1	12	5
	R162311320	15	KWD-015-SLS-C1-H-1	H class, preload C1	12	5
	R162311420	15	KWD-015-SLS-C1-N-1	N class, preload C1	12	5
	R162312220	15	KWD-015-SLS-C2-P-1	P class, preload C2	12	5
	R162312320	15	KWD-015-SLS-C2-H-1	H class, preload C2	12	5
	R162319420	15	KWD-015-SLS-C0-N-1	N class, without preload	12	5
	R162381220	20	KWD-020-SLS-C1-P-1	P class, preload C1	12	5

Page	Part number	Size	Description	Specification	Maximum GoTo quantity (units)	Delivery time (working days) ex works in Germany
	R162381320	20	KWD-020-SLS-C1-H-1	H class, preload C1	12	5
	R162381420	20	KWD-020-SLS-C1-N-1	N class preload C1	12	5
	R162382220	20	KWD-020-SLS-C2-P-1	P class, preload C2	12	5
	R162382320	20	KWD-020-SLS-C2-H-1	H class, preload C2	12	5
	R162389420	20	KWD-020-SLS-C0-N-1	N class, without preload	12	5
	R162321220	25	KWD-025-SLS-C1-P-1	P class, preload C1	12	5
	R162321320	25	KWD-025-SLS-C1-H-1	H class, preload C1	12	5
	R162321420	25	KWD-025-SLS-C1-N-1	N class, preload C1	12	5
	R162322220	25	KWD-025-SLS-C2-P-1	P class, preload C2	12	5
	R162322320	25	KWD-025-SLS-C2-H-1	H class, preload C2	12	5
	R162329420	25	KWD-025-SLS-C0-N-1	N class, without preload	12	5
	R162371220	30	KWD-030-SLS-C1-P-1	P class, preload C1	12	5
	R162371320	30	KWD-030-SLS-C1-H-1	H class, preload C1	12	5
	R162371420	30	KWD-030-SLS-C1-N-1	N class, preload C1	12	5
	R162372220	30	KWD-030-SLS-C2-P-1	P class, preload C2	12	5
	R162372320	30	KWD-030-SLS-C2-H-1	H class, preload C2	12	5
	R162379420	30	KWD-030-SLS-C0-N-1	N class, without preload	12	5
	R162331220	35	KWD-035-SLS-C1-P-1	P class, preload C1	12	5
	R162331320	35	KWD-035-SLS-C1-H-1	H class, preload C1	12	5
	R162331420	35	KWD-035-SLS-C1-N-1	N class, preload C1	12	5
	R162332220	35	KWD-035-SLS-C2-P-1	P class, preload C2	12	5
	R162332320	35	KWD-035-SLS-C2-H-1	H class, preload C2	12	5
	R162339420	35	KWD-035-SLS-C0-N-1	N class, without preload	12	5
	R162341220	45	KWD-045-SLS-C1-P-1	P class, preload C1	12	5
	R162341320	45	KWD-045-SLS-C1-H-1	H class, preload C1	12	5
	R162341420	45	KWD-045-SLS-C1-N-1	N class, preload C1	12	5
	R162342220	45	KWD-045-SLS-C2-P-1	P class, preload C2	12	5
	R162342320	45	KWD-045-SLS-C2-H-1	H class, preload C2	12	5
	R162349420	45	KWD-045-SLS-C0-N-1	N class, without preload	12	5
21	<b>Standard Ball Runner Blocks, steel, SKS, Type R1666</b>					
	R166611320	15	KWD-015-SKS-C1-H-1	H class, preload C1	12	5
	R166611420	15	KWD-015-SKS-C1-N-1	N class, preload C1	12	5
	R166619420	15	KWD-015-SKS-C0-N-1	N class, without preload	12	5
	R166681320	20	KWD-020-SKS-C1-H-1	H class, preload C1	12	5
	R166681420	20	KWD-020-SKS-C1-N-1	N class, preload C1	12	5
	R166689420	20	KWD-020-SKS-C0-N-1	N class, without preload	12	5
	R166621320	25	KWD-025-SKS-C1-H-1	H class, preload C1	12	5
	R166621420	25	KWD-025-SKS-C1-N-1	N class, preload C1	12	5
	R166629420	25	KWD-025-SKS-C0-N-1	N class, without preload	12	5
	R166671320	30	KWD-030-SKS-C1-H-1	H class, preload C1	12	5
	R166671420	30	KWD-030-SKS-C1-N-1	N class, preload C1	12	5
	R166679420	30	KWD-030-SKS-C0-N-1	N class, without preload	12	5
	R166631320	35	KWD-035-SKS-C1-H-1	H class, preload C1	12	5
	R166631420	35	KWD-035-SKS-C1-N-1	N class, preload C1	12	5
	R166639420	35	KWD-035-SKS-C0-N-1	N class, without preload	12	5

Page	Part number	Size	Description	Specification	Maximum GoTo quantity (units)	Delivery time (working days) ex works in Germany
22	<b>Standard Ball Runner Blocks, steel, SNH, Type R1621</b>					
	R162111220	15	KWD-015-SNH-C1-P-1	P class, preload C1	12	5
	R162111320	15	KWD-015-SNH-C1-H-1	H class, preload C1	12	5
	R162111420	15	KWD-015-SNH-C1-N-1	N class, preload C1	12	5
	R162112220	15	KWD-015-SNH-C2-P-1	P class, preload C2	12	5
	R162112320	15	KWD-015-SNH-C2-H-1	H class, preload C2	12	5
	R162119420	15	KWD-015-SNH-C0-N-1	N class, without preload	12	5
	R162121220	25	KWD-025-SNH-C1-P-1	P class, preload C1	12	5
	R162121320	25	KWD-025-SNH-C1-H-1	H class, preload C1	12	5
	R162121420	25	KWD-025-SNH-C1-N-1	N class, preload C1	12	5
	R162122220	25	KWD-025-SNH-C2-P-1	P class, preload C2	12	5
	R162122320	25	KWD-025-SNH-C2-H-1	H class, preload C2	12	5
	R162129420	25	KWD-025-SNH-C0-N-1	N class, without preload	12	5
	R162171220	30	KWD-030-SNH-C1-P-1	P class, preload C1	12	5
	R162171320	30	KWD-030-SNH-C1-H-1	H class, preload C1	12	5
	R162171420	30	KWD-030-SNH-C1-N-1	N class, preload C1	12	5
	R162172220	30	KWD-030-SNH-C2-P-1	P class, preload C2	12	5
	R162172320	30	KWD-030-SNH-C2-H-1	H class, preload C2	12	5
	R162179420	30	KWD-030-SNH-C0-N-1	N class, without preload	12	5
	R162131220	35	KWD-035-SNH-C1-P-1	P class, preload C1	12	5
	R162131320	35	KWD-035-SNH-C1-H-1	H class, preload C1	12	5
	R162131420	35	KWD-035-SNH-C1-N-1	N class, preload C1	12	5
	R162132220	35	KWD-035-SNH-C2-P-1	P class, preload C2	12	5
	R162132320	35	KWD-035-SNH-C2-H-1	H class, preload C2	12	5
	R162139420	35	KWD-035-SNH-C0-N-1	N class, without preload	12	5
	R162141220	45	KWD-045-SNH-C1-P-1	P class, preload C1	12	5
	R162141320	45	KWD-045-SNH-C1-H-1	H class, preload C1	12	5
	R162141420	45	KWD-045-SNH-C1-N-1	N class, preload C1	12	5
	R162142220	45	KWD-045-SNH-C2-P-1	P class, preload C2	12	5
	R162142320	45	KWD-045-SNH-C2-H-1	H class, preload C2	12	5
	R162149420	45	KWD-045-SNH-C0-N-1	N class, without preload	12	5
23	<b>Standard Ball Runner Blocks, steel, SLH, Type R1624</b>					
	R162421220	25	KWD-025-SLH-C1-P-1	P class, preload C1	12	5
	R162421320	25	KWD-025-SLH-C1-H-1	H class, preload C1	12	5
	R162421420	25	KWD-025-SLH-C1-N-1	N class, preload C1	12	5
	R162422220	25	KWD-025-SLH-C2-P-1	P class, preload C2	12	5
	R162422320	25	KWD-025-SLH-C2-H-1	H class, preload C2	12	5
	R162429420	25	KWD-025-SLH-C0-N-1	N class, without preload	12	5
	R162471220	30	KWD-030-SLH-C1-P-1	P class, preload C1	12	5
	R162471320	30	KWD-030-SLH-C1-H-1	H class, preload C1	12	5
	R162471420	30	KWD-030-SLH-C1-N-1	N class, preload C1	12	5
	R162472220	30	KWD-030-SLH-C2-P-1	P class, preload C2	12	5
	R162472320	30	KWD-030-SLH-C2-H-1	H class, preload C2	12	5
	R162479420	30	KWD-030-SLH-C0-N-1	N class, without preload	12	5
	R162431220	35	KWD-035-SLH-C1-P-1	P class, preload C1	12	5
	R162431320	35	KWD-035-SLH-C1-H-1	H class, preload C1	12	5

Page	Part number	Size	Description	Specification	Maximum GoTo quantity (units)	Delivery time (working days) ex works in Germany
	R162431420	35	KWD-035-SLH-C1-N-1	N class, preload C1	12	5
	R162432220	35	KWD-035-SLH-C2-P-1	P class, preload C2	12	5
	R162432320	35	KWD-035-SLH-C2-H-1	H class, preload C2	12	5
	R162439420	35	KWD-035-SLH-C0-N-1	N class, without preload	12	5
	R162441220	45	KWD-045-SLH-C1-P-1	P class, preload C1	12	5
	R162441320	45	KWD-045-SLH-C1-H-1	H class, preload C1	12	5
	R162441420	45	KWD-045-SLH-C1-N-1	N class, preload C1	12	5
	R162442220	45	KWD-045-SLH-C2-P-1	P class, preload C2	12	5
	R162442320	45	KWD-045-SLH-C2-H-1	H class, preload C2	12	5
	R162449420	45	KWD-045-SLH-C0-N-1	N class, without preload	12	5
24	<b>Super Ball Runner Blocks, steel, FKS, Type R1661</b>					
	R166111420	15	KWD-015-FKS-C1-N-1	N class, preload C1	12	5
	R166119420	15	KWD-015-FKS-C0-N-1	N class, without preload	12	5
	R166181420	20	KWD-020-FKS-C1-N-1	N class, preload C1	12	5
	R166189420	20	KWD-020-FKS-C0-N-1	N class, without preload	12	5
	R166121420	25	KWD-025-FKS-C1-N-1	N class, preload C1	12	5
	R166129420	25	KWD-025-FKS-C0-N-1	N class, without preload	12	5
	R166171420	30	KWD-030-FKS-C1-N-1	N class, preload C1	12	5
	R166179420	30	KWD-030-FKS-C0-N-1	N class, without preload	12	5
	R166131420	35	KWD-035-FKS-C1-N-1	N class, preload C1	12	5
	R166139420	35	KWD-035-FKS-C0-N-1	N class, without preload	12	5
25	<b>Super Ball Runner Blocks, steel, SKS, Type R1662</b>					
	R166211420	15	KWD-015-SKS-C1-N-1	N class, preload C1	12	5
	R166219420	15	KWD-015-SKS-C0-N-1	N class, without preload	12	5
	R166281420	20	KWD-020-SKS-C1-N-1	N class, preload C1	12	5
	R166289420	20	KWD-020-SKS-C0-N-1	N class, without preload	12	5
	R166221420	25	KWD-025-SKS-C1-N-1	N class, preload C1	12	5
	R166229420	25	KWD-025-SKS-C0-N-1	N class, without preload	12	5
	R166271420	30	KWD-030-SKS-C1-N-1	N class, preload C1	12	5
	R166279420	30	KWD-030-SKS-C0-N-1	N class, without preload	12	5
	R166231420	35	KWD-035-SKS-C1-N-1	N class, preload C1	12	5
	R166239420	35	KWD-035-SKS-C0-N-1	N class, without preload	12	5
26	<b>Standard Ball Runner Blocks, aluminum, FNS, Type R1631</b>					
	R163111420	15	KWD-015-FNS-C1-N-1	N class, preload C1	12	5
	R163119420	15	KWD-015-FNS-C0-N-1	N class, without preload	12	5
	R163181420	20	KWD-020-FNS-C1-N-1	N class, preload C1	12	5
	R163189420	20	KWD-020-FNS-C0-N-1	N class, without preload	12	5
	R163171420	30	KWD-030-FNS-C1-N-1	N class, preload C1	12	5
	R163179420	30	KWD-030-FNS-C0-N-1	N class, without preload	12	5
	R163121420	25	KWD-025-FNS-C1-N-1	N class, preload C1	12	5
	R163129420	25	KWD-025-FNS-C0-N-1	N class, without preload	12	5
	R163131420	35	KWD-035-FNS-C1-N-1	N class, preload C1	12	5
	R163139420	35	KWD-035-FNS-C0-N-1	N class, without preload	12	5
27	<b>Standard Ball Runner Blocks, aluminum, SNS, Type R1632</b>					
	R163211420	15	KWD-015-SNS-C1-N-1	N class, preload C1	12	5
	R163219420	15	KWD-015-SNS-C0-N-1	N class, without preload	12	5

Page	Part number	Size	Description	Specification	Maximum GoTo quantity (units)	Delivery time (working days) ex works in Germany
	R163281420	20	KWD-020-SNS-C1-N-1	N class, preload C1	12	5
	R163289420	20	KWD-020-SNS-C0-N-1	N class, without preload	12	5
	R163221420	25	KWD-025-SNS-C1-N-1	N class, preload C1	12	5
	R163229420	25	KWD-025-SNS-C0-N-1	N class, without preload	12	5
	R163271420	30	KWD-030-SNS-C1-N-1	N class, preload C1	12	5
	R163279420	30	KWD-030-SNS-C0-N-1	N class, without preload	12	5
	R163231420	35	KWD-035-SNS-C1-N-1	N class, preload C1	12	5
	R163239420	35	KWD-035-SNS-C0-N-1	N class, without preload	12	5
28	<b>Standard Ball Guide Rails, steel, SNS, Type R1605 .0, with plastic mounting hole plugs</b>					
	R160510231	15	KSA-015-SNS-P	P class	6	5
	R160510331	15	KSA-015-SNS-H	H class	6	5
	R160510431	15	KSA-015-SNS-N	N class	6	5
	R160580231	20	KSA-020-SNS-P	P class	6	5
	R160580331	20	KSA-020-SNS-H	H class	6	5
	R160580431	20	KSA-020-SNS-N	N class	6	5
	R160520231	25	KSA-025-SNS-P	P class	6	5
	R160520331	25	KSA-025-SNS-H	H class	6	5
	R160520431	25	KSA-025-SNS-N	N class	6	5
	R160570231	30	KSA-030-SNS-P	P class	6	5
	R160570331	30	KSA-030-SNS-H	H class	6	5
	R160570431	30	KSA-030-SNS-N	N class	6	5
	R160530231	35	KSA-035-SNS-P	P class	6	5
	R160530331	35	KSA-035-SNS-H	H class	6	5
	R160530431	35	KSA-035-SNS-N	N class	6	5
	R160540231	45	KSA-045-SNS-P	P class	6	5
	R160540331	45	KSA-045-SNS-H	H class	6	5
	R160540431	45	KSA-045-SNS-N	N class	6	5
29	<b>Standard Ball Guide Rails, steel, SNS, Type R1605 .6, with cover strip and protective end caps</b>					
	R160516231	15	KSA-015-SNS-P	P class	6	5
	R160516331	15	KSA-015-SNS-H	H class	6	5
	R160516431	15	KSA-015-SNS-N	N class	6	5
	R160586231	20	KSA-020-SNS-P	P class	6	5
	R160586331	20	KSA-020-SNS-H	H class	6	5
	R160586431	20	KSA-020-SNS-N	N class	6	5
	R160526231	25	KSA-025-SNS-P	P class	6	5
	R160526331	25	KSA-025-SNS-H	H class	6	5
	R160526431	25	KSA-025-SNS-N	N class	6	5
	R160576231	30	KSA-030-SNS-P	P class	6	5
	R160576331	30	KSA-030-SNS-H	H class	6	5
	R160576431	30	KSA-030-SNS-N	N class	6	5
	R160536261	35	KSA-035-SNS-P	P class	6	5
	R160536361	35	KSA-035-SNS-H	H class	6	5
	R160536461	35	KSA-035-SNS-N	N class	6	5
	R160546261	45	KSA-045-SNS-S	P class	6	5
	R160546361	45	KSA-045-SNS-H	H class	6	5
	R160546461	45	KSA-045-SNS-N	N class	6	5







Page	Part number	Size	Description	Specification	Maximum GoTo quantity (units)	Delivery time (working days) ex works in Germany
30	<b>Standard Ball Guide Rails, steel, SNS, Type R1607, for mounting from below</b>					
	R160710231	15	KSA-015-SNS-P	P class	6	5
	R160710331	15	KSA-015-SNS-H	H class	6	5
	R160710431	15	KSA-015-SNS-N	N class	6	5
	R160780231	20	KSA-020-SNS-P	P class	6	5
	R160780331	20	KSA-020-SNS-H	H class	6	5
	R160780431	20	KSA-020-SNS-N	N class	6	5
	R160720231	25	KSA-025-SNS-P	P class	6	5
	R160720331	25	KSA-025-SNS-H	H class	6	5
	R160720431	25	KSA-025-SNS-N	N class	6	5
	R160770231	30	KSA-030-SNS-P	P class	6	5
	R160770331	30	KSA-030-SNS-H	H class	6	5
	R160770431	30	KSA-030-SNS-N	N class	6	5
	R160730231	35	KSA-035-SNS-P	P class	6	5
	R160730331	35	KSA-035-SNS-H	H class	6	5
	R160730431	35	KSA-035-SNS-N	N class	6	5
	R160740231	45	KSA-045-SNS-P	P class	6	5
	R160740331	45	KSA-045-SNS-H	H class	6	5
	R160740431	45	KSA-045-SNS-H	N class	6	5
31	<b>Wide Ball Runner Blocks, steel, BNS, Type R1671</b>					
	R167151320	20	KWD-020-BNS-C1-H-1	H class, with preload	4	5
	R167151420	20	KWD-020-BNS-C1-N-1	N class, with preload	4	5
	R167121320	25	KWD-025-BNS-C1-H-1	H class, with preload	4	5
	R167121420	25	KWD-025-BNS-C1-N-1	N class, with preload	4	5
	R167131310	35	KWC-035-BNS-C1-H-2	H class, with preload	4	5
	R167131410	35	KWC-035-BNS-C1-N-2	N class, with preload	4	5
32	<b>Wide Ball Guide Rails, steel, BNS, Type R1675 .0, With plastic mounting hole plugs</b>					
	R167550331	20	KSD-020-BNS-H-MA-AK	H class	4	5
	R167550431	20	KSD-020-BNS-N-MA-AK	N class	4	5
	R167520331	25	KSA-025-BNS-H-MA-AK	H class	4	5
	R167520431	25	KSA-025-BNS-N-MA-AK	N class	4	5
	R167530331	35	KSA-035-BNS-H-MA-AK	H class	4	5
	R167530431	35	KSA-035-BNS-N-MA-AK	N class	4	5
33	<b>Standard Ball Runner Blocks NRFG, steel, FNS, Type R2001</b>					
	R200111314	15	NRFG KWD-015-FNS-C1-H-0	H class, with preload	4	5
	R200181314	20	NRFG KWD-020-FNS-C1-H-0	H class, with preload	4	5
	R200121314	25	NRFG KWD-025-FNS-C1-H-0	H class, with preload	4	5
	R200171314	30	NRFG KWD-030-FNS-C1-H-0	H class, with preload	4	5
	R200131314	35	NRFG KWD-035-FNS-C1-H-0	H class, with preload	4	5
34	<b>Standard Ball Runner Blocks NRFG, steel, FLS, Type R2002</b>					
	R200211314	15	NRFG KWD-015-FLS-C1-H-0	H class, with preload	4	5
	R200281314	20	NRFG KWD-020-FLS-C1-H-0	H class, with preload	4	5
	R200221314	25	NRFG KWD-025-FLS-C1-H-0	H class, with preload	4	5
	R200271314	30	NRFG KWD-030-FLS-C1-H-0	H class, with preload	4	5
	R200231314	35	NRFG KWD-035-FLS-C1-H-0	H class, with preload	4	5

Page	Part number	Size	Description	Specification	Maximum GoTo quantity (units)	Delivery time (working days) ex works in Germany
35	<b>Standard Ball Runner Blocks NRRFG, steel, SNS, Type R2011</b>					
	R201111314	15	NRRFG KWD-015-SNS-C1-H-0	H class, with preload	4	5
	R201181314	20	NRRFG KWD-020-SNS-C1-H-0	H class, with preload	4	5
	R201121314	25	NRRFG KWD-025-SNS-C1-H-0	H class, with preload	4	5
	R201171314	30	NRRFG KWD-030-SNS-C1-H-0	H class, with preload	4	5
	R201131314	35	NRRFG KWD-035-SNS-C1-H-0	H class, with preload	4	5
36	<b>Standard Ball Runner Blocks NRRFG, steel, SLS, Type R2012</b>					
	R201211314	15	NRRFG KWD-015-SLS-C1-H-0	H class, with preload	4	5
	R201281314	20	NRRFG KWD-020-SLS-C1-H-0	H class, with preload	4	5
	R201221314	25	NRRFG KWD-025-SLS-C1-H-0	H class, with preload	4	5
	R201271314	30	NRRFG KWD-030-SLS-C1-H-0	H class, with preload	4	5
	R201231314	35	NRRFG KWD-035-SLS-C1-H-0	H class, with preload	4	5
37	<b>Ball Guide Rails Resist NR II, SNS, Type R2045 .0, With plastic mounting hole plugs</b>					
	R204510331	15	NR II KSA-015-SNS-H-MA-AK	H class	4	5
	R204580331	20	NR II KSA-020-SNS-H-MA-AK	H class	4	5
	R204520331	25	NR II KSA-025-SNS-H-MA-AK	H class	4	5
	R204570331	30	NR II KSA-030-SNS-H-MA-AK	H class	4	5
	R204530331	35	NR II KSA-035-SNS-H-MA-AK	H class	4	5
	<b>Miniature Ball Rail Systems</b>					
40	<b>Miniature Ball Runner Blocks, standard, Type R0442</b>					
	R044271201	7	MWA-007-SNS-C1-P-3	P class, with preload	16	5
	R044271301	7	MWA-007-SNS-C1-H-3	H class, with preload	16	5
	R044279401	7	MWA-007-SNS-C0-N-3	N class, with clearance	16	5
	R044281201	9	MWA-009-SNS-C1-P-3	P class, with preload	16	5
	R044281301	9	MWA-009-SNS-C1-H-3	H class, with preload	16	5
	R044289401	9	MWA-009-SNS-C0-N-3	N class, with clearance	16	5
	R044221201	12	MWA-012-SNS-C1-P-3	P class, with preload	16	5
	R044221301	12	MWA-012-SNS-C1-H-3	H class, with preload	16	5
	R044229401	12	MWA-012-SNS-C0-N-3	N class, with clearance	16	5
	R044251201	15	MWA-015-SNS-C1-P-3	P class, with preload	16	5
	R044251301	15	MWA-015-SNS-C1-H-3	H class, with preload	16	5
	R044259401	15	MWA-015-SNS-C0-N-3	N class, with clearance	16	5
	R044201201	20	MWA-020-SNS-C1-P-3	P class, with preload	16	5
	R044201301	20	MWA-020-SNS-C1-H-3	H class, with preload	16	5
	R044209401	20	MWA-020-SNS-C0-N-3	N class, with clearance	16	5
41	<b>Miniature Ball Runner Blocks, long, Type R0444</b>					
	R044471201	7	MWA-007-SLS-C1-P-3	P class, with preload	16	5
	R044471301	7	MWA-007-SLS-C1-H-3	H class, with preload	16	5
	R044479401	7	MWA-007-SLS-C0-N-3	N class, with clearance	16	5
	R044481201	9	MWA-009-SLS-C1-P-3	P class, with preload	16	5
	R044481301	9	MWA-009-SLS-C1-H-3	H class, with preload	16	5
	R044489401	9	MWA-009-SLS-C0-N-3	N class, with clearance	16	5
	R044421201	12	MWA-012-SLS-C1-P-3	P class, with preload	16	5
	R044421301	12	MWA-012-SLS-C1-H-3	H class, with preload	16	5
	R044429401	12	MWA-012-SLS-C0-N-3	N class, with clearance	16	5
	R044451201	15	MWA-015-SLS-C1-P-3	P class, with preload	16	5



Page	Part number	Size	Description	Specification	Maximum GoTo quantity (units)	Delivery time (working days) ex works in Germany
	R044451301	15	MWA-015-SLS-C1-H-3	H class, with preload	16	5
	R044459401	15	MWA-015-SLS-C0-N-3	N class, with clearance	16	5
42	<b>Miniature Ball Guide Rails, standard, without cover strip, Type R0445</b>					
	R044570231	7	MSA-007-SNS-P	P class	8	5
	R044570331	7	MSA-007-SNS-H	H class	8	5
	R044570431	7	MSA-007-SNS-N	N class	8	5
	R044580231	9	MSA-009-SNS-P	P class	8	5
	R044580331	9	MSA-009-SNS-H	H class	8	5
	R044580431	9	MSA-009-SNS-N	N class	8	5
	R044520231	12	MSA-012-SNS-P	P class	8	5
	R044520331	12	MSA-012-SNS-H	H class	8	5
	R044520431	12	MSA-012-SNS-N	N class	8	5
	R044550231	15	MSA-015-SNS-P	P class	8	5
	R044550331	15	MSA-015-SNS-H	H class	8	5
	R044550431	15	MSA-015-SNS-N	N class	8	5
	R044500231	20	MSA-020-SNS-P	P class	8	5
	R044500331	20	MSA-020-SNS-H	H class	8	5
	R044500431	20	MSA-020-SNS-N	N class	8	5
43	<b>Miniature Ball Runner Blocks, wide, Type R0443</b>					
	R044381201	9	MWA-009-BNS-C1-P-3	P class, with preload	16	5
	R044381301	9	MWA-009-BNS-C1-H-3	H class, with preload	16	5
	R044389401	9	MWA-009-BNS-C0-N-3	N class, with clearance	16	5
	R044321201	12	MWA-012-BNS-C1-P-3	P class, with preload	16	5
	R044321301	12	MWA-012-BNS-C1-H-3	H class, with preload	16	5
	R044329401	12	MWA-012-BNS-C0-N-3	N class, with clearance	16	5
	R044351201	15	MWA-015-BNS-C1-P-3	P class, with preload	16	5
	R044351301	15	MWA-015-BNS-C1-H-3	H class, with preload	16	5
	R044359401	15	MWA-015-BNS-C0-N-3	N class, with clearance	16	5
44	<b>Miniature Ball Runner Blocks, wide, long, Type R0441</b>					
	R044121201	12	MWA-012-BLS-C1-P-3	P class, with preload	16	5
	R044121301	12	MWA-012-BLS-C1-H-3	H class, with preload	16	5
	R044129401	12	MWA-012-BLS-C0-N-3	N class, with clearance	16	5
	R044151201	15	MWA-015-BLS-C1-P-3	P class, with preload	16	5
	R044151301	15	MWA-015-BLS-C1-H-3	H class, with preload	16	5
	R044159401	15	MWA-015-BLS-C0-N-3	N class, with clearance	16	5
45	<b>Miniature Ball Guide Rails, wide, without cover strip, Type R0455</b>					
	R045580231	9	MSA-009-BNS-P	P class	8	5
	R045580331	9	MSA-009-BNS-H	H class	8	5
	R045580431	9	MSA-009-BNS-N	N class	8	5
	R045520231	12	MSA-012-BNS-P	P class	8	5
	R045520331	12	MSA-012-BNS-H	H class	8	5
	R045520431	12	MSA-012-BNS-N	N class	8	5
	R045550231	15	MSA-015-BNS-P	P class	8	5
	R045550331	15	MSA-015-BNS-H	H class	8	5
	R045550431	15	MSA-015-BNS-N	N class	8	5

Page	Part number	Size	Description	Specification	Maximum GoTo quantity (units)	Delivery time (working days) ex works in Germany
<b>Linear Bushings and Shafts</b>						
48	<b>Compact Linear Bushings, closed, Type R0658</b>					
	R065820830	8	KBC-8-DD-NR	Corrosion-resistant, with seals	16	5
	R065820840	8	KBC-8-DD	Corrosion-resistant, with seals	16	5
	R065821030	10	KBC-10-DD-NR	Corrosion-resistant	16	5
	R065821040	10	KBC-10-DD	Corrosion-resistant, with seals	16	5
	R065821230	12	KBC-12-DD-NR	Corrosion-resistant	16	5
	R065821240	12	KBC-12-DD	Corrosion-resistant, with seals	16	5
	R065821630	16	KBC-16-DD-NR	Corrosion-resistant	16	5
	R065821640	16	KBC-16-DD	Corrosion-resistant, with seals	16	5
	R065822030	20	KBC-20-DD-NR	Corrosion-resistant	16	5
	R065822040	20	KBC-20-DD	Corrosion-resistant, with seals	16	5
	R065822530	25	KBC-25-DD-NR	Corrosion-resistant	16	5
	R065822540	25	KBC-25-DD	Corrosion-resistant, with seals	16	5
	R065823030	30	KBC-30-DD-NR	Corrosion-resistant	16	5
	R065823040	30	KBC-30-DD	Corrosion-resistant, with seals	16	5
	R065824030	40	KBC-40-DD-NR	Corrosion-resistant	8	5
	R065824040	40	KBC-40-DD	Corrosion-resistant, with seals	8	5
	R065825030	50	KBC-50-DD-NR	Corrosion-resistant	8	5
	R065825040	50	KBC-50-DD	Corrosion-resistant, with seals	8	5
50	<b>Linear Sets with Compact Linear Bushings, closed, normal or corrosion-resistant, Type R1027</b>					
	R102721244	12	LSAC-12-DD-G	With seals	8	5
	R102721644	16	LSAC-16-DD-G	With seals	8	5
	R102722034	20	LSAC-20-DD-NR-G	Corrosion-resistant, with seals	8	5
	R102722044	20	LSAC-20-DD-G	With seals	8	5
	R102722534	25	LSAC-25-DD-NR-G	Corrosion-resistant, with seals	8	5
	R102722544	25	LSAC-25-DD-G	With seals	8	5
	R102723034	30	LSAC-30-DD-NR-G	Corrosion-resistant, with seals	8	5
	R102723044	30	LSAC-30-DD-G	With seals	8	5
	R102724034	40	LSAC-40-DD-NR-G	Corrosion-resistant, with seals	4	5
	R102724044	40	LSAC-40-DD-G	With seals	4	5
	R102725044	50	LSAC-50-DD-G	With seals	4	5
51	<b>Linear Sets with Compact Linear Bushings, adjustable, Type R1028</b>					
	R102821244	12	LSACE-12-DD-G	With seals	8	5
	R102821644	16	LSACE-16-DD-G	With seals	8	5
	R102822044	20	LSACE-20-DD-G	With seals	8	5
	R102822544	25	LSACE-25-DD-G	With seals	8	5
	R102823044	30	LSACE-30-DD-G	With seals	8	5
	R102824044	40	LSACE-40-DD-G	With seals	4	5
	R102825044	50	LSACE-50-DD-G	With seals	4	5
52	<b>Super Linear Bushings , closed, Type R0670</b>					
	R067001000	10	KBA-10	Without seals	16	5
	R067021040	10	KBA-10-DD	With seals	16	5
	R067001200	12	KBA-12	Without seals	16	5
	R067021240	12	KBA-12-DD	With seals	16	5

Page	Part number	Size	Description	Specification	Maximum GoTo quantity (units)	Delivery time (working days) ex works in Germany
	R067001600	16	KBA-16	Without seals	16	5
	R067021640	16	KBA-16-DD	With seals	16	5
	R067002000	20	KBA-20	Without seals	16	5
	R067022040	20	KBA-20-DD	With seals	16	5
	R067002500	25	KBA-25	Without seals	16	5
	R067022540	25	KBA-25-DD	With seals	16	5
	R067003000	30	KBA-30	Without seals	16	5
	R067023040	30	KBA-30-DD	With seals	16	5
	R067004000	40	KBA-40	Without seals	8	5
	R067024040	40	KBA-40-DD	With seals	8	5
	R067005000	50	KBA-50	Without seals	8	5
	R067025040	50	KBA-50-DD	With seals	8	5
53	<b>Linear Sets with Super Linear Bushings , closed, Type R1035</b>					
	R103561220	12	LSA-A-12-DD	With seals	8	5
	R103561620	16	LSA-A-16-DD	With seals	8	5
	R103562020	20	LSA-A-20-DD	With seals	8	5
	R103562520	25	LSA-A-25-DD	With seals	8	5
	R103563020	30	LSA-A-30-DD	With seals	8	5
	R103564020	40	LSA-A-40-DD	With seals	4	5
	R103565020	50	LSA-A-50-DD	With seals	4	5
54	<b>Linear Sets with Super Linear Bushings , adjustable, Type R1036</b>					
	R103661220	12	LSAE-A-12-DD	Adjustable, with seals	8	5
	R103661620	16	LSAE-A-16-DD	Adjustable, with seals	8	5
	R103662020	20	LSAE-A-20-DD	Adjustable, with seals	8	5
	R103662520	25	LSAE-A-25-DD	Adjustable, with seals	8	5
	R103663020	30	LSAE-A-30-DD	Adjustable, with seals	8	5
	R103664020	40	LSAE-A-40-DD	Adjustable, with seals	4	5
	R103665020	50	LSAE-A-50-DD	Adjustable, with seals	4	5
55	<b>Linear Sets with Super Linear Bushings , closed, tandem, Type R1085</b>					
	R108561220	12	LSAT-A-12-DD	With seals	8	5
	R108561620	16	LSAT-A-16-DD	With seals	8	5
	R108562020	20	LSAT-A-20-DD	With seals	8	5
	R108562520	25	LSAT-A-25-DD	With seals	8	5
	R108563020	30	LSAT-A-30-DD	With seals	8	5
	R108564020	40	LSAT-A-40-DD	With seals	4	5
	R108565020	50	LSAT-A-50-DD	With seals	4	5
56	<b>Linear Sets with Super Linear Bushings , adjustable, tandem, Type R1032</b>					
	R103261220	12	LSATE-A-12-DD	With seals	8	5
	R103261620	16	LSATE-A-16-DD	With seals	8	5
	R103262020	20	LSATE-A-20-DD	With seals	8	5
	R103262520	25	LSATE-A-25-DD	With seals	8	5
	R103263020	30	LSATE-A-30-DD	With seals	8	5
	R103264020	40	LSATE-A-40-DD	With seals	4	5
	R103265020	50	LSATE-A-50-DD	With seals	4	5

Page	Part number	Size	Description	Specification	Maximum GoTo quantity (units)	Delivery time (working days) ex works in Germany
57	<b>Linear Sets with Super Linear Bushings , closed, tandem, flanged, Type R1083</b>					
	R108361220	12	LSAFT-A-12-DD	With seals	8	5
	R108361620	16	LSAFT-A-16-DD	With seals	8	5
	R108362020	20	LSAFT-A-20-DD	With seals	8	5
	R108362520	25	LSAFT-A-25-DD	With seals	8	5
	R108363020	30	LSAFT-A-30-DD	With seals	8	5
58	<b>Linear Sets with Super Linear Bushings , adjustable, cast iron housing, Type R1066</b>					
	R106662040	20	LSGE-A-20-DD	With seals	8	5
	R106663040	30	LSGE-A-30-DD	With seals	8	5
	R106664040	40	LSGE-A-40-DD	With seals	4	5
59	<b>Linear Sets with Super Linear Bushings , flanged, cast iron housing, Type R1081</b>					
	R108161640	16	LSGF-A-16-DD	With seals	8	5
	R108162040	20	LSGF-A-20-DD	With seals	8	5
	R108162540	25	LSGF-A-25-DD	With seals	8	5
	R108163040	30	LSGF-A-30-DD	With seals	8	5
	R108164040	40	LSGF-A-40-DD	With seals	4	5
	R108165040	50	LSGF-A-50-DD	With seals	4	5
60	<b>Super Linear Bushing , closed, Type R0672</b>					
	R067221040	10	KBB-10-DD	With seals	4	5
	R067221240	12	KBB-12-DD	With seals	4	5
	R067221640	16	KBB-16-DD	With seals	4	5
	R067222040	20	KBB-20-DD	With seals	4	5
	R067222540	25	KBB-25-DD	With seals	4	5
	R067223040	30	KBB-30-DD	With seals	4	5
	R067224040	40	KBB-40-DD	With seals	4	5
	R067225040	50	KBB-50-DD	With seals	4	5
61	<b>Super Linear Bushing , closed, Type R0732</b>					
	R073222040	20	KBH-20-DD	With seals	4	5
	R073222540	25	KBH-25-DD	With seals	4	5
	R073223040	30	KBH-30-DD	With seals	4	5
	R073224040	40	KBH-40-DD	With seals	4	5
	R073225040	50	KBH-50-DD	With seals	4	5
62	<b>Super Linear Bushing , closed, Type R0730</b>					
	R073022040	20	KBSH-20-DD	With seals	4	5
	R073022540	25	KBSH-25-DD	With seals	4	5
	R073023040	30	KBSH-30-DD	With seals	4	5
	R073024040	40	KBSH-40-DD	With seals	4	5
	R073025040	50	KBSH-50-DD	With seals	4	5
63	<b>Standard Linear Bushings, closed, Type R0600 and R0602</b>					
	R060030800	8	KBM-8	Without seals	16	5
	R060230810	8	KBM-8-DD	With seals	16	5
	R060001200	12	KBM-12	Without seals	16	5
	R060201210	12	KBM-12-DD	With seals	16	5
	R060001600	16	KBM-16	Without seals	16	5

Page	Part number	Size	Description	Specification	Maximum GoTo quantity (units)	Delivery time (working days) ex works in Germany
	R060201610	16	KBM-16-DD	With seals	16	5
	R060002000	20	KBM-20	Without seals	16	5
	R060202010	20	KBM-20-DD	With seals	16	5
	R060002500	25	KBM-25	Without seals	16	5
	R060202510	25	KBM-25-DD	With seals	16	5
	R060003000	30	KBM-30	Without seals	16	5
	R060203010	30	KBM-30-DD	With seals	16	5
	R060004000	40	KBM-40	Without seals	8	5
	R060204010	40	KBM-40-DD	With seals	8	5
	R060005000	50	KBM-50	Without seals	8	5
	R060205010	50	KBM-50-DD	With seals	8	5
64	<b>Standard Linear Bushings, closed, corrosion-resistant, Type R0602</b>					
	R060200830	8	KBM-8-DD-NR	Corrosion-resistant, with seals	4	5
	R060201230	12	KBM-12-DD-NR	Corrosion-resistant, with seals	4	5
	R060201630	16	KBM-16-DD-NR	Corrosion-resistant, with seals	4	5
	R060202030	20	KBM-20-DD-NR	Corrosion-resistant, with seals	4	5
	R060202530	25	KBM-25-DD-NR	Corrosion-resistant, with seals	4	5
65	<b>Standard Linear Bushings, adjustable, Type R0610 and R0612</b>					
	R061030800	8	KBM-E-8	Adjustable, without seals	16	5
	R061230810	8	KBM-E-8-DD	Adjustable, with seals	16	5
	R061001200	12	KBM-E-12	Adjustable, without seals	16	5
	R061201210	12	KBM-E-12-DD	Adjustable, with seals	16	5
	R061001600	16	KBM-E-16	Adjustable, without seals	16	5
	R061201610	16	KBM-E-16-DD	Adjustable, with seals	16	5
	R061002000	20	KBM-E-20	Adjustable, without seals	16	5
	R061202010	20	KBM-E-20-DD	Adjustable, with seals	16	5
	R061002500	25	KBM-E-25	Adjustable, without seals	16	5
	R061202510	25	KBM-E-25-DD	Adjustable, with seals	16	5
	R061003000	30	KBM-E-30	Adjustable, without seals	16	5
	R061203010	30	KBM-E-30-DD	Adjustable, with seals	16	5
	R061004000	40	KBM-E-40	Adjustable, without seals	8	5
	R061204010	40	KBM-E-40-DD	Adjustable, with seals	8	5
	R061005000	50	KBM-E-50	Adjustable, without seals	8	5
	R061205010	50	KBM-E-50-DD	Adjustable, with seals	8	5
66	<b>Linear Sets with Standard Linear Bushings, adjustable, cast iron housing, Type R1066</b>					
	R106622500	25	LSGE-M-25-DD	With seals	8	5
	R106623000	30	LSGE-M-30-DD	With seals	8	5
	R106624000	40	LSGE-M-40-DD	With seals	4	5
	R106625000	50	LSGE-M-50-DD	With seals	4	5
67	<b>Linear Sets with Standard Linear Bushings, flanged, cast iron housing, Type R1081</b>					
	R108121600	16	LSGF-M-16-DD	With seals	8	5
	R108122000	20	LSGF-M-20-DD	With seals	8	5
	R108122500	25	LSGF-M-25-DD	With seals	8	5
	R108123000	30	LSGF-M-30-DD	With seals	8	5
	R108124000	40	LSGF-M-40-DD	With seals	4	5
	R108125000	50	LSGF-M-50-DD	With seals	4	5

Page	Part number	Size	Description	Specification	Maximum GoTo quantity (units)	Delivery time (working days) ex works in Germany
68	<b>Segmental Linear Bushing, closed, normal or corrosion-resistant, Type R0668</b>					
	R066801200	12	KBSE-12	Heat-treated steel	4	5
	R066801230	12	KBSE-12-NR	Corrosion-resistant	4	5
	R066801600	16	KBSE-16	Heat-treated steel	4	5
	R066801630	16	KBSE-16-NR	Corrosion-resistant	4	5
	R066802000	20	KBSE-20	Heat-treated steel	4	5
	R066802030	20	KBSE-20-NR	Corrosion-resistant	4	5
	R066802500	25	KBSE-25	Heat-treated steel	4	5
	R066802530	25	KBSE-25-NR	Corrosion-resistant	4	5
	R066803000	30	KBSE-30	Heat-treated steel	4	5
	R066803030	30	KBSE-30-NR	Corrosion-resistant	4	5
	R066804000	40	KBSE-40	Heat-treated steel	4	5
	R066804030	40	KBSE-40-NR	Corrosion-resistant	4	5
69	<b>Precision Steel Shafts, solid, Type R1000</b>					
	R100000800	8	8 H6	Heat-treated steel	8	10
	R100000830	8	8 H6 NR - X46	Corrosion-resistant	8	10
	R100001000	10	10 H6	Heat-treated steel	8	10
	R100001030	10	10 H6 NR - X46	Corrosion-resistant	8	10
	R100001200	12	12 H6	Heat-treated steel	8	10
	R100001230	12	12 H6 NR - X46	Corrosion-resistant	8	10
	R100001600	16	16 H6	Heat-treated steel	8	10
	R100001630	16	16 H6 NR - X46	Corrosion-resistant	8	10
	R100002000	20	20 H6	Heat-treated steel	8	10
	R100002020	20	20 H6 NR - X90	Corrosion-resistant	4	5
	R100002030	20	20 H6 NR - X46	Corrosion-resistant	8	10
	R100002500	25	25 H6	Heat-treated steel	8	10
	R100002520	25	25 H6 NR - X90	Corrosion-resistant	4	5
	R100002530	25	25 H6 NR - X46	Corrosion-resistant	8	10
	R100002560	25	25 H6 CR	Hard chrome plated	8	10
	R100003000	30	30 H6	Heat-treated steel	8	10
	R100003020	30	30 H6 NR - X90	Corrosion-resistant	4	5
	R100003030	30	30 H6 NR - X46	Corrosion-resistant	8	10
	R100003060	30	30 H6 CR	Hard chrome plated	8	10
	R100004000	40	40 H6	Heat-treated steel	4	10
	R100004020	40	40 H6 NR - X90	Corrosion-resistant	4	5
	R100004030	40	40 H6 NR - X46	Corrosion-resistant	4	10
	R100004060	40	40 H6 CR	Hard chrome plated	4	10
	R100005000	50	50 H6	Heat-treated steel	4	10
	R100005020	50	50 H6 NR - X90	Corrosion-resistant	4	5
	R100005030	50	50 H6 NR - X46	Corrosion-resistant	4	10
	R100005060	50	50 H6 CR	Hard chrome plated	4	10
70	<b>Precision Steel Shafts, tubular, Type R1001</b>					
	R100102510	25	25 H6	Heat-treated steel	4	10
	R100103010	30	30 H6	Heat-treated steel	4	10

Page	Part number	Size	Description	Specification	Maximum GoTo quantity (units)	Delivery time (working days) ex works in Germany
	R100103041	30	30 H7 CR	Hard chrome plated	4	10
	R100104010	40	40 H6	Heat-treated steel	4	10
	R100104041	40	40 H7 CR	Hard chrome plated	4	10
	R100105010	50	50 H6	Heat-treated steel	4	10
	R100105041	50	50 H7 CR	Hard chrome plated	4	10
71	<b>Compact Shaft Support Blocks, aluminum Type R1058</b>					
	R105801200	12	WBA-12C-FO		4	5
	R105801600	16	WBA-16C-FO		4	5
	R105802000	20	WBA-20C-FO		4	5
	R105802500	25	WBA-25C-FO		4	5
	R105803000	30	WBA-30C-FO		4	5
	R105804000	40	WBA-40C-FO		4	5
	R105805000	50	WBA-50C-FO		4	5
72	<b>Shaft Support Blocks, aluminium, Type R1057</b>					
	R105701000	10	WBA-10		16	5
	R105701200	12	WBA-12		16	5
	R105701600	16	WBA-16		16	5
	R105702000	20	WBA-20		16	5
	R105702500	25	WBA-25		16	5
	R105703000	30	WBA-30		16	5
	R105704000	40	WBA-40		8	5
	R105705000	50	WBA-50		8	5
	<b>Ball Screw Assemblies</b>					
74	<b>Flanged Single Nuts FEM-E-C, standard, Type R1502</b>					
	R150201065	16X5	FEM-E-C 16X5RX3-4	Standard backlash	10	5
	R150204085	16X10	FEM-E-C 16X10RX3-3	Standard backlash	10	5
	R150206065	16X16	FEM-E-C 16X16RX3-3	Standard backlash	10	5
	R150211085	20X5	FEM-E-C 20X5RX3-4	Standard backlash	10	5
	R150217065	20X20	FEM-E-C 20X20RX3,5-3	Standard backlash	10	5
	R150221085	25X5	FEM-E-C 25X5RX3-4	Standard backlash	10	5
	R150224085	25X10	FEM-E-C 25X10RX3-4	Standard backlash	10	5
	R150228065	25X25	FEM-E-C 25X25RX3,5-3	Standard backlash	10	5
	R150231085	32X5	FEM-E-C 32X5RX3,5-4	Standard backlash	10	5
	R150234086	32X10	FEM-E-C 32X10RX3,969-5	Standard backlash	10	5
	R150237065	32X20	FEM-E-C 32X20RX3,969-3	Standard backlash	10	5
	R150239065	32X32	FEM-E-C 32X32RX3,969-3	Standard backlash	10	5
	R150241086	40X5	FEM-E-C 40X5RX3,5-5	Standard backlash	10	5
	R150244085	40X10	FEM-E-C 40X10RX6-4	Standard backlash	10	5
	R150247085	40X20	FEM-E-C 40X20RX6-3	Standard backlash	10	5
75	<b>Flanged Single Nuts FEM-E-S, standard, Type R1512</b>					
	R153223003	8x2,5	FEM-E-S 8x2,5	Standard backlash	4	5
	R153246023	12x5	FEM-E-S 12x5	Standard backlash	4	5
	R151201023	16X5	FEM-E-S 16X5RX3-4	Standard backlash	10	5
	R151204013	16X10	FEM-E-S 16X10RX3-3	Standard backlash	10	5
	R151206013	16X16	FEM-E-S 16X16RX3-2	Standard backlash	10	5
	R151211013	20X5	FEM-E-S 20X5RX3-4	Standard backlash	10	5



Page	Part number	Size	Description	Specification	Maximum GoTo quantity (units)	Delivery time (working days) ex works in Germany
	R151214013	20X10	FEM-E-S 20X10RX3-4	Standard backlash	10	5
	R151217013	20X20	FEM-E-S 20X20RX3,5-2	Standard backlash	10	5
	R151221013	25X5	FEM-E-S 25X5RX3-4	Standard backlash	10	5
	R151224013	25X10	FEM-E-S 25X10RX3-4	Standard backlash	10	5
	R151228013	25X25	FEM-E-S 25X25RX3,5-2	Standard backlash	10	5
	R151231013	32X5	FEM-E-S 32X5RX3,5-4	Standard backlash	10	5
	R151234013	32X10	FEM-E-S 32X10RX3,969-5	Standard backlash	10	5
	R151237013	32X20	FEM-E-S 32X20RX3,969-2	Standard backlash	10	5
	R151239013	32X32	FEM-E-S 32X32RX3,969-2	Standard backlash	10	5
	R151241013	40X5	FEM-E-S 40X5RX3,5-5	Standard backlash	10	5
	R151244013	40X10	FEM-E-S 40X10RX6-4	Standard backlash	10	5
	R151247013	40X20	FEM-E-S 40X20RX6-3	Standard backlash	10	5
	R151249013	40X40	FEM-E-S 40X40RX6-2	Standard backlash	10	5
<b>77</b>	<b>Precision-Rolled Screws SN-R, Type R1511</b>					
	R153123500	8x2,5	Precision screw 8x2,5 T5	Cut, cut and annealed	4	5
	R153123700	8x2,5	Precision screw 8x2,5 T7	Cut, cut and annealed	4	5
	R153123900	8x2,5	Precision screw 8x2,5 T9	Cut, cut and annealed	4	5
	R153146510	12x5	Precision screw 12x5 T5	Cut, cut and annealed	4	5
	R153146710	12x5	Precision screw 12x5 T7	Cut, cut and annealed	4	5
	R153146910	12x5	Precision screw 12x5 T9	Cut, cut and annealed	4	5
	R151101500	16x5	Precision screw 16x5Rx3	Cut, cut and annealed	20	10
	R151101700	16x5	Precision screw 16x5Rx3	Cut, cut and annealed	20	10
	R151101900	16x5	Precision screw 16x5Rx3	Cut, cut and annealed	20	10
	R151104500	16x10	Precision screw 16x10Rx3	Cut, cut and annealed	20	10
	R151104700	16x10	Precision screw 16x10Rx3	Cut, cut and annealed	20	10
	R151104900	16x10	Precision screw 16x10Rx3	Cut, cut and annealed	20	10
	R151106510	16x16	Precision screw 16x16Rx3	Cut, cut and annealed	20	10
	R151106710	16x16	Precision screw 16x16Rx3	Cut, cut and annealed	20	10
	R151106910	16x16	Precision screw 16x16Rx3	Cut, cut and annealed	20	10
	R151111500	20x5	Precision screw 20x5Rx3	Cut, cut and annealed	20	10
	R151111700	20x5	Precision screw 20x5Rx3	Cut, cut and annealed	20	10
	R151111900	20x5	Precision screw 20x5Rx3	Cut, cut and annealed	20	10
	R151117510	20x20	Precision screw 20x20Rx3,5	Cut, cut and annealed	20	10
	R151117710	20x20	Precision screw 20x20Rx3,5	Cut, cut and annealed	20	10
	R151117910	20x20	Precision screw 20x20Rx3,5	Cut, cut and annealed	20	10
	R151121500	25x5	Precision screw 25x5Rx3	Cut, cut and annealed	20	10
	R151121700	25x5	Precision screw 25x5Rx3	Cut, cut and annealed	20	10
	R151121900	25x5	Precision screw 25x5Rx3	Cut, cut and annealed	20	10
	R151124500	25x10	Precision screw 25x10Rx3	Cut, cut and annealed	20	10
	R151124700	25x10	Precision screw 25x10Rx3	Cut, cut and annealed	20	10
	R151124900	25x10	Precision screw 25x10Rx3	Cut, cut and annealed	20	10
	R151128510	25x25	Precision screw 25x25Rx3,5	Cut, cut and annealed	20	10
	R151128710	25x25	Precision screw 25x25Rx3,5	Cut, cut and annealed	20	10
	R151128910	25x25	Precision screw 25x25Rx3,5	Cut, cut and annealed	20	10
	R151131500	32x5	Precision screw 32x5Rx3,5	Cut, cut and annealed	20	10
	R151131700	32x5	Precision screw 32x5Rx3,5	Cut, cut and annealed	20	10



Page	Part number	Size	Description	Specification	Maximum GoTo quantity (units)	Delivery time (working days) ex works in Germany
	R151131900	32x5	Precision screw 32x5Rx3,5	Cut, cut and annealed	20	10
	R151134510	32x10	Precision screw 32x10Rx3,969	Cut, cut and annealed	20	10
	R151134710	32x10	Precision screw 32x10Rx3,969	Cut, cut and annealed	20	10
	R151134910	32x10	Precision screw 32x10Rx3,969	Cut, cut and annealed	20	10
	R151137510	32x20	Precision screw 32x20Rx3,969	Cut, cut and annealed	20	10
	R151137710	32x20	Precision screw 32x20Rx3,969	Cut, cut and annealed	20	10
	R151137910	32x20	Precision screw 32x20Rx3,969	Cut, cut and annealed	20	10
	R151139510	32x32	Precision screw 32x32Rx3,969	Cut, cut and annealed	20	10
	R151139710	32x32	Precision screw 32x32Rx3,969	Cut, cut and annealed	20	10
	R151139910	32x32	Precision screw 32x32Rx3,969	Cut, cut and annealed	20	10
	R151141500	40x5	Precision screw 40x5Rx3,5	Cut, cut and annealed	20	10
	R151141700	40x5	Precision screw 40x5Rx3,5	Cut, cut and annealed	20	10
	R151141700	40x5	Precision screw 40x5Rx3,5	Cut, cut and annealed	20	10
	R151144500	40x10	Precision screw 40x10Rx6	Cut, cut and annealed	20	10
	R151144700	40x10	Precision screw 40x10Rx6	Cut, cut and annealed	20	10
	R151144900	40x10	Precision screw 40x10Rx6	Cut, cut and annealed	20	10
	R151147500	40x20	Precision screw 40x20Rx6	Cut, cut and annealed	20	10
	R151147700	40x20	Precision screw 40x20Rx6	Cut, cut and annealed	20	10
	R151147900	40x20	Precision screw 40x20Rx6	Cut, cut and annealed	20	10
	R151149510	40x40	Precision screw 40x40Rx6	Cut, cut and annealed	20	10
	R151149710	40x40	Precision screw 40x40Rx6	Cut, cut and annealed	20	10
	R151149910	40x40	Precision screw 40x40Rx6	Cut, cut and annealed	20	10

### Linear Systems

80

#### Electromechanical Cylinders, Type 1560

R156011100	32-12	EMC 32-12	Fixed length 100 mm	5	5
R156012100	32-12	EMC 32-12	Fixed length 100 mm	5	5
R156011200	32-12	EMC 32-12	Fixed length 200 mm	5	5
R156012200	32-12	EMC 32-12	Fixed length 200 mm	5	5
R156021100	40-16	EMC 40-16	Fixed length 100 mm	5	5
R156022100	40-16	EMC 40-16	Fixed length 100 mm	5	5
R156021200	40-16	EMC 40-16	Fixed length 200 mm	5	5
R156022200	40-16	EMC 40-16	Fixed length 200 mm	5	5
R156023200	40-16	EMC 40-16	Fixed length 200 mm	5	5
R156021320	40-16	EMC 40-16	Fixed length 320 mm	5	5
R156022320	40-16	EMC 40-16	Fixed length 320 mm	5	5
R156021400	40-16	EMC 40-16	Fixed length 400 mm	5	5
R156022400	40-16	EMC 40-16	Fixed length 400 mm	5	5
R156031100	50-20	EMC 50-20	Fixed length 100 mm	5	5
R156031200	50-20	EMC 50-20	Fixed length 200 mm	5	5
R156034200	50-20	EMC 50-20	Fixed length 200 mm	5	5
R156031400	50-20	EMC 50-20	Fixed length 400 mm	5	5
R156041100	63-25	EMC 63-25	Fixed length 100 mm	5	5
R156041200	63-25	EMC 63-25	Fixed length 200 mm	5	5
R156042200	63-25	EMC 63-25	Fixed length 200 mm	5	5
R156041400	63-25	EMC 63-25	Fixed length 400 mm	5	5
R156042400	63-25	EMC 63-25	Fixed length 400 mm	5	5

Page	Part number	Size	Description	Specification	Maximum GoTo quantity (units)	Delivery time (working days) <b>ex works in Germany</b>
	R156051100	80-32	EMC 80-32	Fixed length 100 mm	5	5
	R156051200	80-32	EMC 80-32	Fixed length 200 mm	5	5
	R156052200	80-32	EMC 80-32	Fixed length 200 mm	5	5
	R156052400	80-32	EMC 80-32	Fixed length 400 mm	5	5
	R156061200	100-40	EMC 100-40	Fixed length 200 mm	5	5
	R156064400	100-40	EMC 100-40	Fixed length 400 mm	5	5

Please state the required stroke when ordering.

**Abbreviations used**

<b>RSF</b>	Roller Rail Systems
<b>KSF</b>	Ball Rail Systems
<b>Mini-KSF</b>	Miniature Ball Rail Systems
<b>KBF</b>	Linear Bushings and Shafts
<b>KGT</b>	Ball Screw Assemblies
<b>EMC</b>	Electromechanical Cylinder

**Explanation of technical symbols used**

<b>a<sub>max</sub></b>	m/s <sup>2</sup>	Maximum acceleration
<b>C</b>	N	Dynamic load capacity
<b>C<sub>max</sub></b>	N	Maximum dynamic load capacity
<b>C<sub>0</sub></b>	N	Static load capacity (rating)
<b>C<sub>0 max</sub></b>	N	Maximum static load capacity (rating)
<b>F<sub>max</sub></b>	N	Maximum dynamic load
<b>J<sub>s</sub></b>	kgm <sup>2</sup>	Mass moment of inertia of system without external load
<b>M<sub>L</sub></b>	Nm	Dynamic longitudinal moment load capacity
<b>M<sub>L max</sub></b>	Nm	Maximum permissible longitudinal load moment
<b>M<sub>p</sub></b>	Nm	Maximum permissible drive torque
<b>M<sub>t</sub></b>	Nm	Dynamic torsional moment load capacity
<b>M<sub>t max</sub></b>	Nm	Maximum permissible torsional moment
<b>m</b>	kg	Mass
<b>v<sub>max</sub></b>	m/s	Maximum travel speed







**Bosch Rexroth AG**

Ernst-Sachs-Straße 100  
97424 Schweinfurt, Germany  
Tel. +49 9721 937-0  
Fax +49 9721 937-275  
info@boschrexroth.de  
www.boschrexroth.com

**Find your local contact person here:**

[www.boschrexroth.com/contact](http://www.boschrexroth.com/contact)