

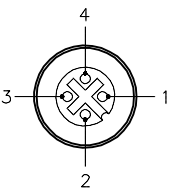

FEMALE END VIEW	MALE END VIEW	WIRING DIAGRAM	SPECIFICATIONS	
			CONTACT CARRIER MATERIAL/COLOR	NYLON OR TPU/YELLOW
			MOLDED HEAD MATERIAL/COLOR	TPU/YELLOW
			CONTACT MATERIAL/PLATING	BRASS/GOLD
			COUPLING NUT MATERIAL/PLATING	BRASS/NICKEL
			RATED CURRENT [A]	4.0 A
			RATED VOLTAGE [V]	250 V
			TEMPERATURE RATING	-40°C to +105°C (-40°F to +221°F)
			PROTECTION CLASS	MEETS NEMA 1,3,4,6P AND IEC IP68

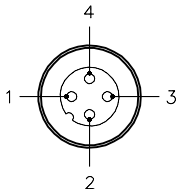
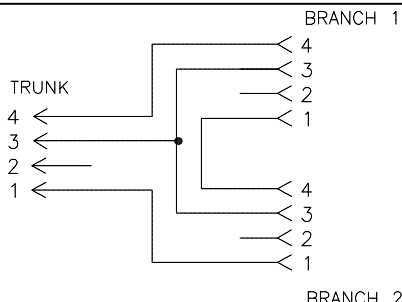

SOURCE DRAWING - FOR REFERENCE ONLY

NOTES:

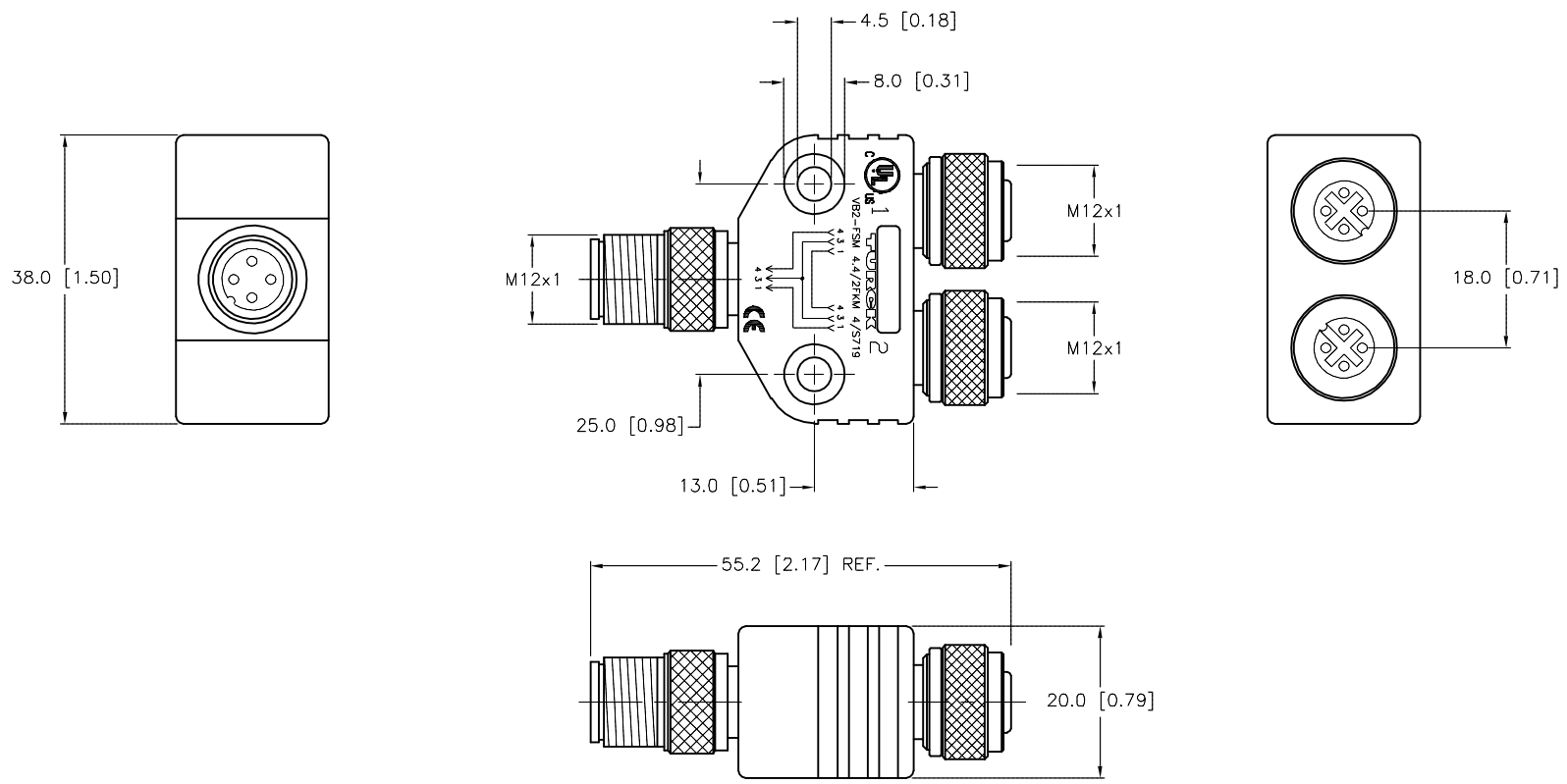
- "*" INDICATES CABLE LENGTH IN METERS. CONTACT TURCK TO ORDER SPECIFIC LENGTHS.
- "/S719" DESIGNATES SERIES WIRING.
- "/SV" DESIGNATES SPECIAL PACKAGING FOR VENDING MACHINES.

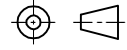
RELATED DOCUMENTS 1. 2. 3. 4.	3RD ANGLE PROJECTION 	THIS DRAWING IS CONFIDENTIAL AND THE PROPERTY OF TURCK INC. USE OF THIS DOCUMENT WITHOUT WRITTEN PERMISSION IS PROHIBITED.		3000 CAMPUS DRIVE MINNEAPOLIS, MN 55441 1-800-544-7769 (763) 553-7300 (763) 553-0708 fax www.turck.us	
	MATERIAL	DRFT	RWC	DATE	12/17/07
	SEE SPECIFICATIONS	APVD		SCALE	1=1.0
	FINISH	UNIT OF MEASUREMENT MILLIMETER [INCH]		DESCRIPTION	VB2-FSM 4.4/2FKM 4/S719/SV
SEE SPECIFICATIONS	CONTACT TURCK FOR MORE INFORMATION	DO NOT SCALE THIS DRAWING		IDENTIFICATION NO. U2-12880	REV C
		FILE: U2-12880		SHEET 1 OF 1	

C	UPDATE CLICHE	TR	08/29/18	65811
REV	DESCRIPTION	BY	DATE	ECO NO.