

GE Fanuc Automation Europe

Computer Numerical Controls



*I/O Unit - Model A
Connection*

Maintenance Manual

B-63813EN/03



DEFINITION OF WARNING, CAUTION, AND NOTE

This manual includes safety precautions for protecting the user and preventing damage to the machine. Precautions are classified into Warning and Caution according to their bearing on safety. Also, supplementary information is described as a Note. Read the Warning, Caution, and Note thoroughly before attempting to use the machine.

WARNING

Applied when there is a danger of the user being injured or when there is a damage of both the user being injured and the equipment being damaged if the approved procedure is not observed.

CAUTION

Applied when there is a danger of the equipment being damaged, if the approved procedure is not observed.

NOTE

The Note is used to indicate supplementary information other than Warning and Caution.

- Read this manual carefully, and store it in a safe place.

PREFACE

This manual describe the following products:

Applicable models

| Name of products | Abbreviation |
|-------------------------|---------------------|
| FANUC I/O Unit-MODEL A | I/O Unit-A |
| FANUC I/O Unit-MODEL B | I/O Unit-B |

Applicable CNCs

| Name of products | Abbreviation |
|-----------------------------|---------------------|
| FANUC Power Mate-MODEL A | Power Mate-A |
| FANUC Power Mate-MODEL B | Power Mate-B |
| FANUC Power Mate-MODEL C | Power Mate-C |
| FANUC Series 0(MODEL C) | Series 0-C |
| FANUC Series 15 | Series 15 |
| FANUC Series 16 | Series 16 |
| FANUC Series 18 | Series 18 |
| FANUC SYSTEM F-MODEL D Mate | F-D Mate |

PREFACE

I CONNECTIONS

| | |
|------------------------------------------------------------------------------|----|
| 1. FANUC I/O LINK..... | 3 |
| 1.1 CONFIGURATION..... | 4 |
| 1.2 ALLOCATION OF I/O POINTS..... | 5 |
| 2. I/O UNIT CONFIGURATION..... | 8 |
| 3. INSTALLATION..... | 9 |
| 3.1 ENVIRONMENTAL CONDITIONS..... | 9 |
| 3.2 DESIGNING CONDITION FOR A CABINET..... | 10 |
| 3.3 OUTER DIMENSION OF I/O Unit..... | 11 |
| 3.4 MOUNTING AND DISMOUNTING MODULES..... | 13 |
| 4. CONNECTION..... | 14 |
| 4.1 GENERAL CONNECTION DIAGRAM..... | 14 |
| 4.2 CONNECTING INPUT POWER SOURCE..... | 15 |
| 4.3 GROUNDING..... | 16 |
| 4.4 REQUIRED CURRENT..... | 17 |
| 4.5 INTERFACE MODULE (AIF01A, AIF01B)..... | 18 |
| 4.6 INTERFACE MODULE (AIF02C) CONNECTION..... | 21 |
| 4.6.1 Overview..... | 21 |
| 4.6.2 Connection..... | 22 |
| 4.6.3 Setting with the DIP switch..... | 24 |
| 4.7 CONNECTING WITH I/O MODULES..... | 25 |
| 5. DIGITAL INPUT / OUTPUT MODULES..... | 27 |
| 5.1 LIST OF MODULES..... | 27 |
| 5.2 CORRESPONDENCE BETWEEN I/O SIGNALS AND ADDRESSES IN A MODULE..... | 29 |
| 5.3 SPECIFICATION FOR EACH MODULE..... | 30 |
| 6. ANALOG INPUT MODULE (AAD04A)..... | 61 |
| 6.1 SPECIFICATIONS FOR ANALOG INPUT MODULE..... | 61 |
| 6.2 CORRESPONDENCE BETWEEN INPUT SIGNALS AND ADDRESSES IN A MODULE..... | 62 |
| 6.3 CONNECTING WITH ANALOG INPUT MODULE..... | 64 |
| 7. ANALOG OUTPUT MODULE..... | 65 |
| 7.1 12-BIT ANALOG OUTPUT MODULE (ADA02A)..... | 65 |
| 7.1.1 Specification..... | 65 |
| 7.1.2 Correspondence between Output Signals and Addresses in a Module..... | 66 |
| 7.1.3 Connection to Analog Output Module..... | 67 |
| 7.2 FOURTEEN-BIT ANALOG OUTPUT MODULE (ADA02B)..... | 68 |
| 7.2.1 Specification..... | 68 |
| 7.2.2 Correspondence between Output Signals and Addresses in the Module..... | 68 |
| 7.2.3 Connection between the Analog Output Module and Load..... | 69 |

| | |
|-----------------------------------------------------------------|------------|
| 8. HIGH SPEED COUNTER MODULE | 70 |
| 8.1 OUTLINE OF HIGH SPEED COUNTER MODULE..... | 70 |
| 8.2 SPECIFICATIONS OF HIGH SPEED COUNTER MODULE..... | 72 |
| 8.2.1 Pulse counter..... | 72 |
| 8.2.2 Comparison function..... | 72 |
| 8.2.3 Pulse Interface..... | 74 |
| 8.2.4 External contact input..... | 76 |
| 8.2.5 External contact output..... | 76 |
| 8.2.6 Marker processing..... | 76 |
| 8.2.7 LED Indicators..... | 77 |
| 8.3 PMC INTERFACE..... | 79 |
| 8.3.1 Mode A..... | 79 |
| 8.3.2 Mode B..... | 81 |
| 8.3.3 Details of PMC interface signals..... | 83 |
| 8.4 TOTAL CONNECTION OF HIGH SPEED COUNTER MODULE..... | 86 |
| 8.4.1 Connection diagram..... | 86 |
| 8.4.2 Connector signal list..... | 87 |
| 8.5 CONNECTION WITH PULSE GENERATOR..... | 88 |
| 8.5.1 Use of phase A and B pulses..... | 88 |
| 8.5.2 Use of positive/negative pulses..... | 89 |
| 8.6 CONNECTION WITH POWER MAGNETICS CABINET..... | 90 |
| 8.7 I/O SIGNALS CONVENTIONS..... | 91 |
| 8.7.1 Solid state relay output signals (OUT0 to OUT7)..... | 91 |
| 8.7.2 DC input signals (ME and CSP)..... | 92 |
| 8.8 SUPPLEMENT..... | 93 |
| 8.8.1 Configuration of mode A..... | 93 |
| 8.8.2 Counter presetting and counting..... | 94 |
| 8.8.3 Setting data..... | 95 |
| 8.8.4 Reading data..... | 97 |
| 8.8.5 Miscellaneous information..... | 98 |
| 9. TEMPERATURE INPUT MODULE | 99 |
| 9.1 OVERVIEW..... | 99 |
| 9.2 TEMPERATURE INPUT MODULE SPECIFICATION..... | 100 |
| 9.3 PMC INTERFACE..... | 101 |
| 9.3.1 PMC I/O area..... | 101 |
| 9.3.2 Measurement mode..... | 102 |
| 9.3.3 Details of output signals (PMC → temperature module)..... | 102 |
| 9.3.4 Details of input signals (temperature module → PMC)..... | 104 |
| 9.4 COMPLETE CONNECTION OF TEMPERATURE INPUT MODULE..... | 107 |
| 9.4.1 Temperature input module connection diagram..... | 107 |
| 9.4.2 Connector signal lists..... | 108 |
| 9.4.3 Terminal board unit connection diagram..... | 109 |
| 9.5 TIMING CHARTS..... | 110 |
| 9.6 MEASUREMENT EXAMPLES..... | 111 |
| 9.7 TERMINAL BOARD UNIT DIMENSIONS..... | 118 |
| 10. OPTICAL I/O LINK ADAPTER | 119 |
| 10.1 EXTERNAL DIMENSION OF OPTICAL I/O LINK..... | 120 |
| 10.2 WEIGHT OF OPTICAL I/O LINK..... | 120 |
| 10.3 CONNECTION OF OPTICAL I/O LINK..... | 121 |
| 10.4 POWER SOURCE OF OPTICAL I/O LINK ADAPTER..... | 121 |
| 10.5 INSTALLATION CONDITIONS OF OPTICAL I/O LINK ADAPTER..... | 122 |
| 10.6 OPTICAL FIBER CABLE..... | 122 |
| 10.6.1 External view of optical fiber cable..... | 122 |
| 10.6.2 Notice of optical fiber cable handling..... | 123 |
| 10.6.3 Optical fiber cable clamping method..... | 124 |
| 10.6.4 Relay using an optical fiber adapter..... | 125 |

| | | |
|---------------------------|----------------------------------------------------------------------------------------------|------------|
| 10.6.5 | Maximum transmission distance by optical fiber cable | 125 |
| 11. | I/O LINK DUMMY UNIT | 126 |
| 11.1 | OVERVIEW | 126 |
| 11.2 | EXTERNAL DIMENSIONS | 126 |
| 11.3 | LED INDICATORS | 127 |
| 11.4 | WEIGHT | 127 |
| 11.5 | POWER REQUIREMENTS | 127 |
| 11.6 | INSTALLATION CONDITIONS | 127 |
| 11.7 | CONNECTION DIAGRAMS | 128 |
| 11.7.1 | When not connecting FANUC I/O Link dummy units in series | 128 |
| 11.7.2 | Connecting FANUC I/O Link dummy units in series | 129 |
| 11.7.3 | Grounding | 129 |
| 11.7.4 | K3X cable | 130 |
| 12. | SAFETY FOR USING AC | 131 |
| 12.1 | INSTALLATION ENVIRONMENT | 132 |
| 12.1.1 | Installation Category (Overvoltage Category) | 132 |
| 12.1.2 | Pollution Degree | 132 |
| II MAINTENANCE | | |
| 1. | OVERVIEW | 135 |
| 1.1 | SYSTEM CONFIGURATION | 135 |
| 1.2 | I/O UNIT-A CONFIGURATION | 136 |
| 1.3 | BLOCK DIAGRAM | 137 |
| 1.4 | LIST OF UNITS | 138 |
| 2. | INDICATION | 140 |
| 2.1 | INTERFACE MODULE (AIF01A) LEDS | 140 |
| 2.2 | INTERFACE MODULE (AIF01B) LEDS | 144 |
| 2.3 | INTERFACE MODULE (AIF02C) LED INDICATORS | 146 |
| 2.3.1 | PWR indicator | 146 |
| 2.3.2 | LNK indicators | 146 |
| 2.3.3 | ER indicators | 146 |
| 2.3.4 | LED indicators | 146 |
| 2.3.5 | M/S indicator | 147 |
| 2.3.6 | No. Indicators | 148 |
| 2.4 | LED INDICATORS ON THE INPUT/OUTPUT MODULES (HAVING 16 OR FEWER INPUT/OUTPUT POINTS) | 148 |
| 3. | FUSES | 149 |
| 4. | REMOVING PC BOARDS | 150 |
| 4.1 | HOW TO REMOVE TERMINAL BOARD-TYPE I/O MODULE PC BOARDS | 150 |
| 4.2 | HOW TO REMOVE INTERFACE AND CONNECTOR-TYPE I/O MODULE PC BOARDS | 152 |

I. CONNECTIONS

1

FANUC I/O Link

I/O Link is a serial interface with a purpose to transfer I/O signals (bit data) between CNC, cell controller, the I/O Unit-A, the Power Mate-A, etc. at high speed.

1.1 CONFIGURATION

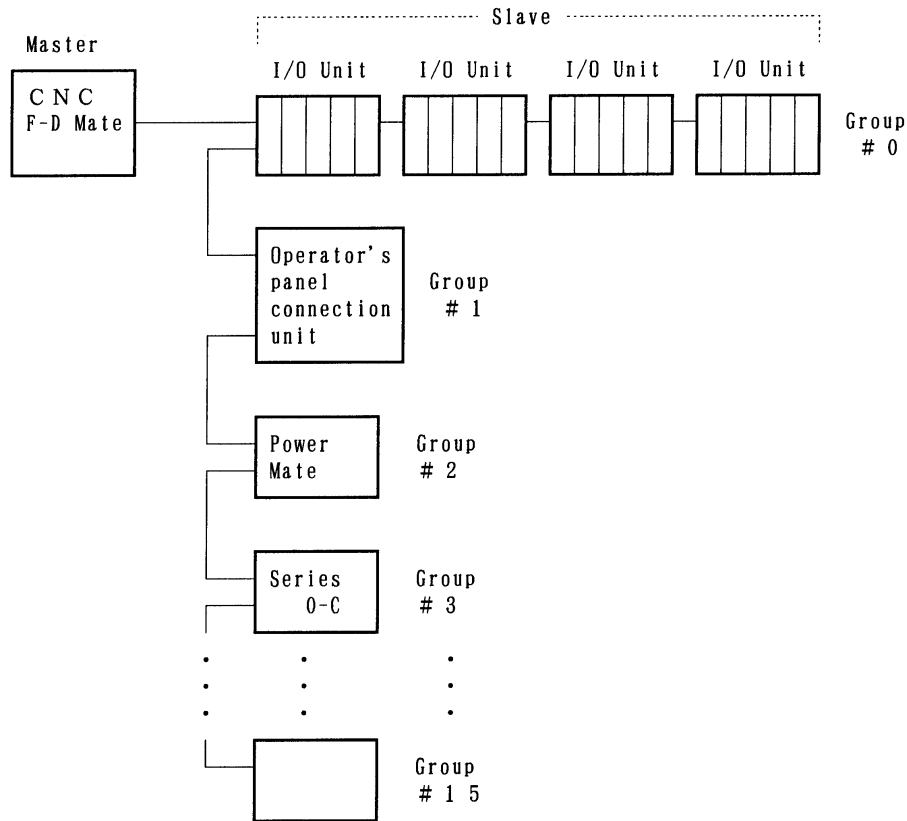

- 1) The FANUC I/O Link is made up of one master and a number of slaves.
 Master : Series 0-C, Series 15/16/18/20/21, Series 15i/16i/18i/20i/21i, Power Mate-D/H, Power Mate i-D/H, F-D Mate
 Slave : I/O Unit-A, Power Mate operator's panel connection unit, Series 0-C

- 2) Up to 16 groups of slaves can be connected with a single I/O Link. Number of slaves per one group is as follows.
 I/O Unit-A : Up to 4 units (i.e.4 bases) but when Master is CNC and Pwer Mate up to 2 units.
 Power Mate : 1
 Operator's panel connection unit : 1
 Series 0-C, : 1

- 3) Any slave can be connected with any group. However, different types of slaves can not be connected with a single group.

1.2 ALLOCATION OF I/O POINTS

I/O Link has 1024 input points and 1024 output points as viewed from the master.

I/O data is periodically transferred between the master and slaves by allotting these I/O points to each slave.

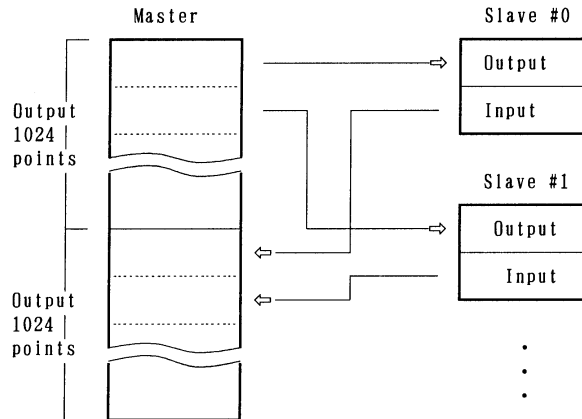

Each slave occupies specified number of I/O points. Sum of I/O points occupied by all slaves in an I/O Link is restricted as follows:

- Number of input points 1024
- Number of output points 1024

Number of actual I/O points may differ from that of the occupied ones. How to determine the number of I/O points to be allotted to each slave and restrictions for allocation are shown in the followings.

(For the allocation method for I/O points, refer to the PMC PROGRAMMING MANUAL.)

Number of actual and occupied I/O points are shown in Table 1.2.

Table 1.2

| Kind of slave | Actual I/O points | | Occupied I/O point | | Remarks | |
|----------------------------------|--------------------------|---------------------------|----------------------|---------------|---------|------------------------------------|
| | Input points | Output points | Input points | Output points | | |
| I/O Unit-A | Each input module points | Each output module points | Refer 3 of next page | | | |
| Operator's panel connection unit | A | 96 | 64 | 128 | 64 | |
| | B | 64 | 32 | | | |
| Power Mate | | 32 | 32 | 32 | 32 | Either I/O point can be allocated. |
| | | 64 | 64 | 64 | 64 | |
| Series 0-C | | 32 | 32 | 32 | 32 | Either I/O point can be allocated. |
| | | 64 | 64 | 64 | 64 | |

- 1) Sum the numbers of the occupied I/O points in Table 1 for all slaves connected with a single I/O Link. The sum must satisfy the following restriction :

Number of input points 1024 (per one I/O Link)

Number of output points 1024 (per one I/O Link)

- 2) Number of the occupied I/O points per one group must satisfy the following restriction :

Number of input points 256 (per one group)

Number of output points 256 (per one group)

- 3) Determine the number of I/O points for the I/O Unit-A using the following.

[Output points]

| Sum of the actual output points in a group | | Occupied output points |
|--------------------------------------------|---|------------------------|
| 0 to 32 | ⇒ | 32 points |
| 40 to 64 | ⇒ | 64 points |
| 72 to 128 | ⇒ | 128 points |
| 136 to 256 | ⇒ | 256 points |

NOTE

Count AOA05E as 8 points AOA12F as 16 points.

[Input points]

| Sum of the actual output points in a group | | Occupied output points |
|--------------------------------------------|---|------------------------|
| 0 to 32 | ⇒ | 32 points |
| 40 to 64 | ⇒ | 64 points |
| 72 to 128 | ⇒ | 128 points |
| 136 to 256 | ⇒ | 256 points |

However, as result of the calculation above, when the number of input points is not larger than that of the output points in a single group, the number of input points is assumed to be equal to that of the output points.

Example 1 : When the following modules are used in the group No. 0.

AOD32C 3 AID32A 5

AOA12F 2 AIA16G 3

[Output points]

$$32 \times 3 + 16 \times 2 = 128 \Rightarrow 128 \text{ points}$$

[Input points]

$$32 \times 5 + 16 \times 3 = 208 \Rightarrow 256 \text{ points}$$

Example 2: When the following modules are used in the group No.2

AOD16C 7 AID16C 4

AOA05E 9 AIA16G 3

[Output points]

$$16 \times 7 + 8 \times 9 = 184 \Rightarrow 256 \text{ points}$$

[Input points]

$$16 \times 4 + 16 \times 3 = 112 \Rightarrow 128 \text{ points}$$

In this case, as the number of input points is not larger than that of the output points, the number of input points is assumed to be equal to that of the output points, in other words, 256 points.

2

I/O UNIT CONFIGURATION

5-slot horizontal base unit (ABU05A)

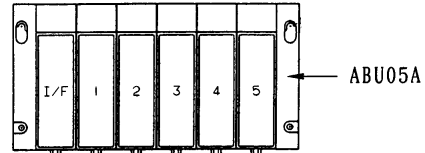

10-slot horizontal base unit (ABU10A)

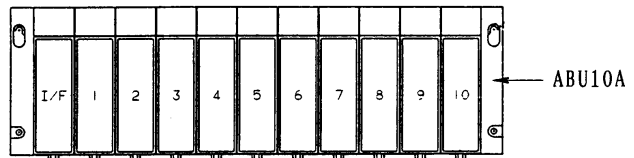

5-slot vertical base unit (ABU05B)

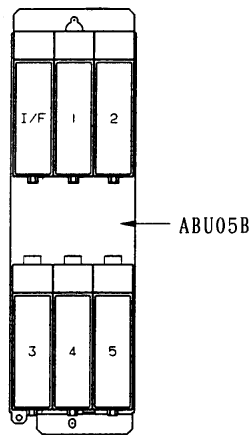

10-slot vertical base unit (ABU10B)

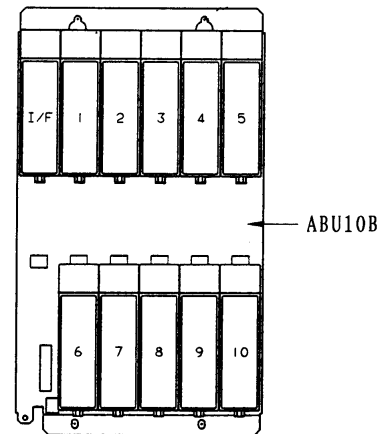

NOTE
I/F :Interface module (AIF01A, AIF01B, or AIF02C)
1 to 10: I/O modules

3

INSTALLATION

3.1 ENVIRONMENTAL CONDITIONS

Install the cabinet containing the I/O Unit-A where the following conditions are satisfied.

- 1) Surrounding temperature
During operation: 0 to 45
During preservation and transportation: -20 to 60
- 2) Temperature changing rate: Max. 1.1 /min
- 3) Humidity
Normal condition: 75% or less (relative humidity)
Short period (one month or shorter): Max.95%
- 4) Vibration
During operation: 0.5G or less
- 5) Atmosphere
When the unit is used in areas with high density of dust, cutting fluid or organic solvent, the user should consult FANUC.

3.2 DESIGNING CONDITION FOR A CABINET

When designing a cabinet to contain the I/O Unit-A, take the same care as taken for the cabinet containing the CNC control unit and other units. For details, refer to the CNC CONNECTING MANUAL.

In addition, when mounting the I/O unit, conform to the followings in view of maintenance, environmental durability, noise resistance and the like.

- 1) In order to ventilate inside the module well, mount the I/O unit in the direction shown in the figure below.

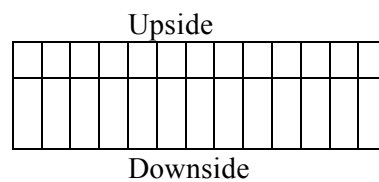

- 2) Mount the I/O unit vertically apart from other units by 100 mm or more taking ventilation and wiring into consideration.
- 3) Do not put equipments which generate a large amount of heat under the I/O unit.
- 4) Low-level signals are transferred through the signal cables K1X and K2X. (For these cables, see the general connection diagram.) Lay out these cables apart from the wires for AC power source and the I/O wires of the I/O module by 100 mm or more.
- 5) Make sure that there is no protruding portion such as a screw on the mounting surface of the I/O unit.
- 6) Heat values of I/O unit are listed in Table 3.3

3.3 OUTER DIMENSION OF I/O Unit

Horizontal base units (ABU05A and ABU10A)

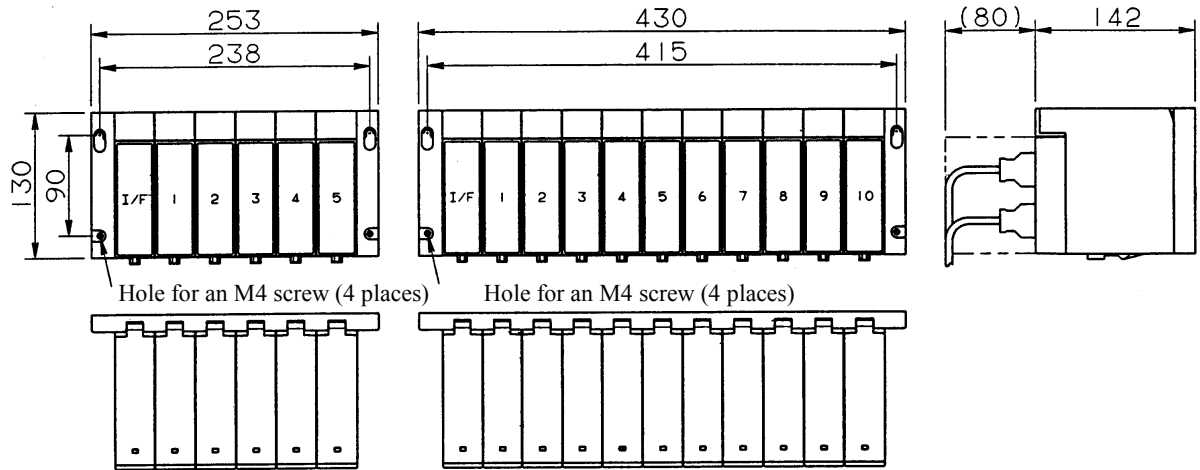

Vertical base units (ABU05B and ABU10B)

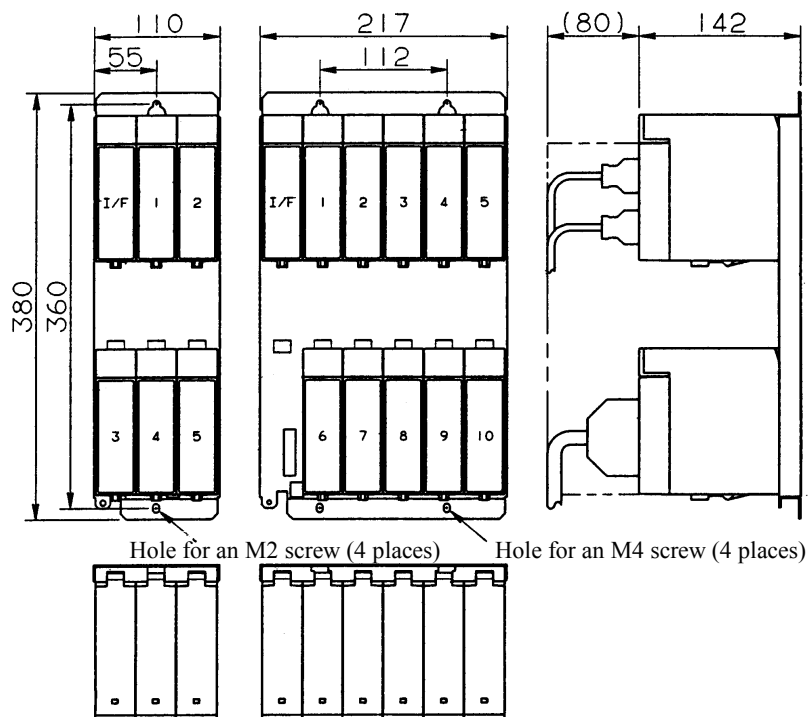

Table 3.3 Heat value of each module

| | Module name | Basic heat value (W) | Heat value per 1 I/O point (W) |
|----|-------------|----------------------|--------------------------------|
| | AIF01A | 1.2 | - |
| | AIF01B | 1.2 | - |
| *1 | AID32A1 | 1.2 | 0.23 |
| *2 | AID32B1 | 1.2 | 0.23 |
| | AID32H1 | 1.2 | 0.23 |
| | AID16C | 0.1 | 0.21 |
| | AID16K | 0.1 | 0.21 |
| | AID16D | 0.1 | 0.21 |
| | AID16L | 0.1 | 0.21 |
| *3 | AID32E1 | 0.1 | 0.23 |
| | AID32E2 | 0.1 | 0.23 |
| *4 | AID32F1 | 0.1 | 0.23 |
| | AID32F2 | 0.1 | 0.23 |
| | AIA16G | 0.1 | 0.21 |
| *5 | AOD32A1 | 0.3 | - |
| | AOD08C | 0.1 | $0.04+0.4\times IL^2$ |
| | AOD08D | 0.1 | $0.04+0.6\times IL^2$ |
| | AOD16C | 0.1 | $0.04+1.4\times IL^2$ |
| | AOD16D | 0.1 | $0.04+1.4\times IL^2$ |
| *6 | AOD32C1 | 0.1 | $0.01+0.8\times IL^2$ |
| | AOD32C2 | 0.1 | $0.01+0.8\times IL^2$ |
| *7 | AOD32D1 | 0.1 | $0.01+0.8\times IL^2$ |
| | AOD32D2 | 0.1 | $0.01+0.8\times IL^2$ |
| | AOA05E | 0.1 | $0.13+1.5\times IL$ |
| | AOA08E | 0.1 | $0.13+1.5\times IL$ |
| | AOA12F | 0.1 | $0.11+1.5\times IL$ |
| | AOR08G | 0.1 | $0.3+0.1\times IL^2$ |
| | AOR16G | 0.1 | $0.3+0.1\times IL^2$ |
| | AOR16H2 | 0.1 | $0.3+0.1\times IL^2$ |
| | AAD04A | 3.1 | - |
| | ADA02A | 3.1 | - |
| | ADA02B | 3.1 | - |
| | ACT01A | 4.1 | - |
| | ATI04A | 4.0 | - |
| | ATI04B | 4.0 | - |

- Total 'Heat value per 1 I/O point' for simultaneous ON points plus 'Basic heat value' is the heat value of the module.
- IL : Load current of output
- A□ D32□ 1 of " *1 to *7" is the same module as former A□ D32□
(Example : AID32E1 is equal to former AID32E.)

3.4 MOUNTING AND DISMOUNTING MODULES

Interface modules and various types of I/O modules can be mounted to and dismantled from the base unit easily as shown below.

Mounting

Hang the hook at the top of the module on the groove in the upper side of the base unit, and make the connector of the module engage with that of the base unit. Push the module in the lower groove of the base unit till the stopper in the lower side of the module stops.

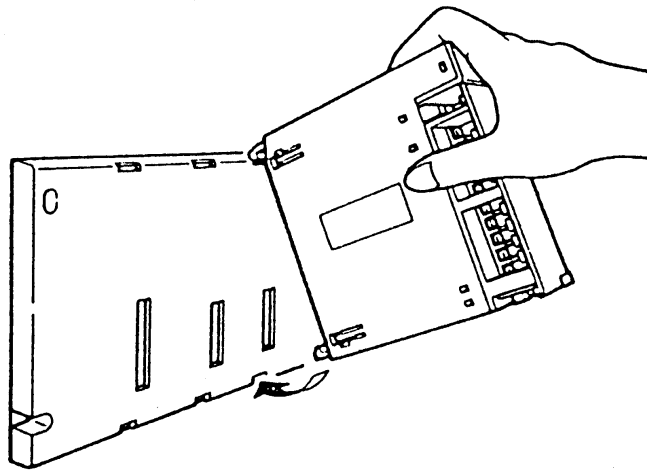

Dismounting

Release the stopper by pushing the lever at the bottom of the module, and then push the module upwards.

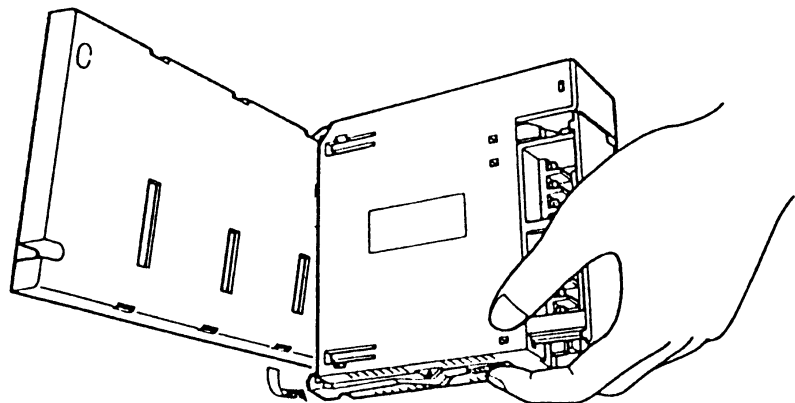

4 CONNECTION

4.1 GENERAL CONNECTION DIAGRAM

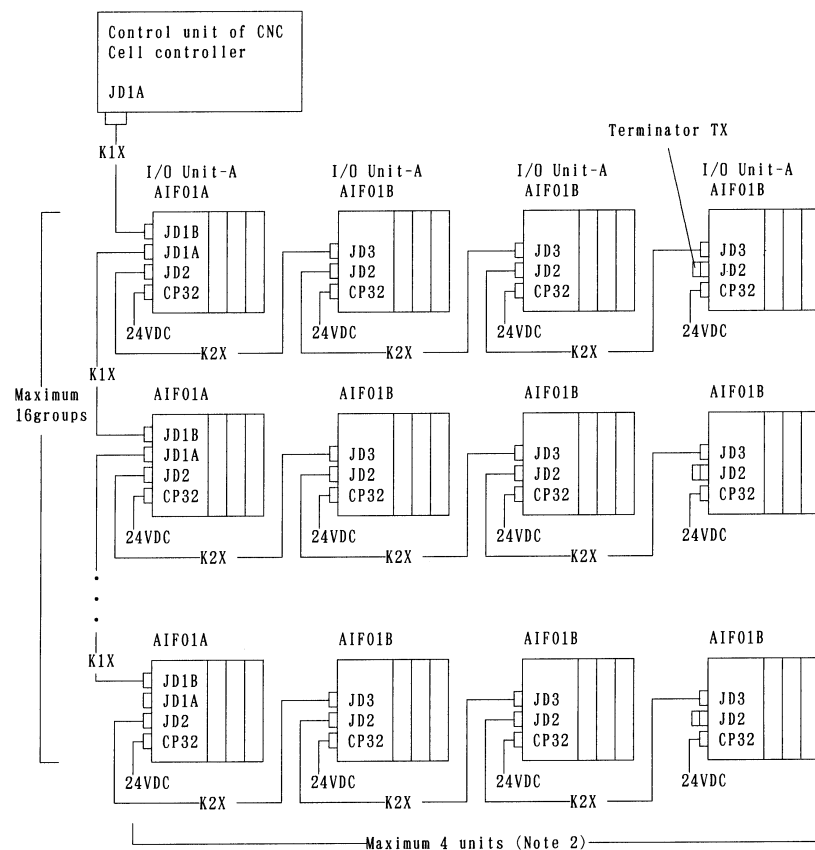

NOTE

- 1 Number of I/O Units and connecting method are restricted depending on the allocation of the I/O points. Refer to the section 1.2, "Allocation of I/O points."
- 2 The number of I/O units per group is limited to 2 when the master equipment is the CNC.
- 3 Cable K1X can be an optical fiber cable by using the optical I/O link adapter. See chapter 10.
- 4 Terminator TX is required for connector JD2 of the AIF01B that is the last unit to be connected in the group. The terminator is not required when the AIF01B is not used.

4.2 CONNECTING INPUT POWER SOURCE

Connect the following power source with the connector CP32 of the interface module (AIF01A, AIF01B, or AIF02C).

- Voltage: 24VDC \pm 10%
- Current: Determine from Table 4.4

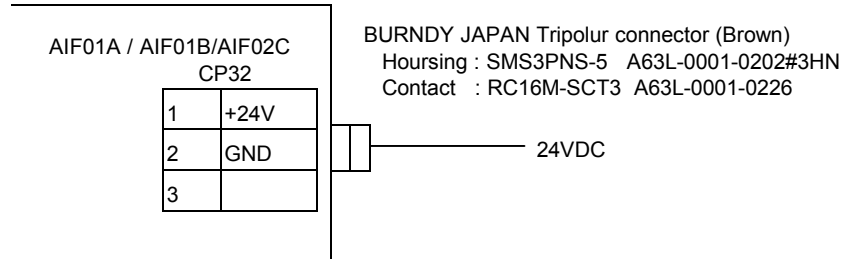

NOTE

Turn ON the power for the I/O unit just when or before the power for the CNC or the cell controller is turned ON. When the CNC or cell controller power is turned OFF, make sure to turn the power to the I/O unit OFF as well. If the power is not turned on and off according to the above procedure, an error occurs in the CNC or the controller, or the I/O unit is not normally connected to the power.

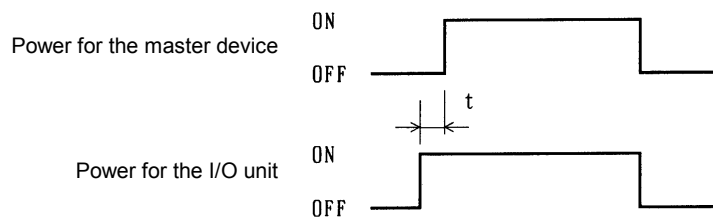

$t \geq 500$ ms (Turn ON of the power for I/O unit can be late 500 ms or less.)

4.3 GROUNDING

Connect the grounding terminal of the base unit (ABU05A, ABU05B, ABU10A, or ABU10B) to ground.

- (1) Horizontal type base unit

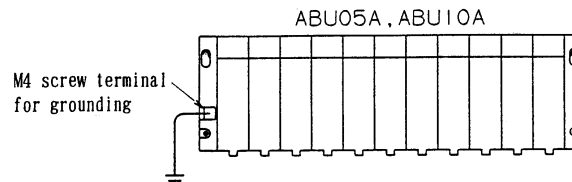

Use a wire of 2 mm² or more for grounding.

- (2) Vertical type base unit
(a) For metal case

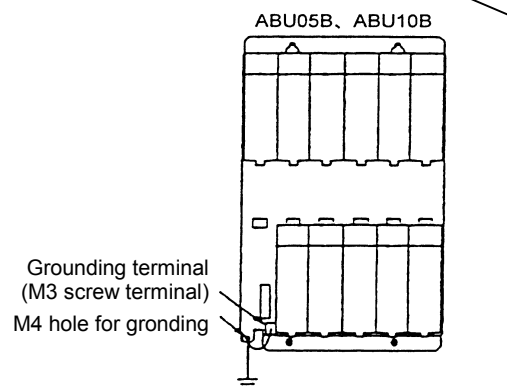

NOTE

Connect the grounding terminal to the grounding hole portion.

- (b) For plastic case

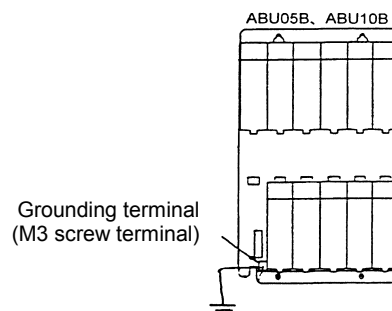

- (2) When the cable K1X (See overall connection figure in section 4.1) runs between different cabinets, make sure to connect the cabinets with a wire more than 5.5 mm².

4.4 REQUIRED CURRENT

Table 4.4 Required current of each module

| Module name | Required current (mA) of+24V | |
|-------------|------------------------------|--------------------|
| | A | B |
| AIF01A | 50 | |
| AIF01B | 50 | |
| AIF0K | 50 | |
| AID32A1 | $20+0.5 \times n$ | $3.0+7.5 \times n$ |
| AID32B1 | $20+0.5 \times n$ | $3.0+7.5 \times n$ |
| AID32H1 | $20+0.5 \times n$ | $3.0+7.5 \times n$ |
| AID16C | 5 | |
| AID16K | 5 | |
| AID16D | 5 | |
| AID16L | 5 | |
| AID32E1 | 5 | |
| AID32E2 | 5 | |
| AID32F1 | 5 | |
| AID32F2 | 5 | |
| AIA16G | $5+1.5 \times n$ | |
| AOD32A1 | 14 | |
| AOD08C | $5+2 \times n$ | |
| AOD08D | $5+2 \times n$ | |
| AOD16C | $5+2 \times n$ | |
| AOD16D | $5+2 \times n$ | |
| AOD32C1 | $5+0.5 \times n$ | |
| AOD32C2 | $5+0.5 \times n$ | |
| AOD32D1 | $5+0.5 \times n$ | |
| AOD32D2 | $5+0.5 \times n$ | |
| AOA05E | $5+5.5 \times n$ | |
| AOA08E | $5+5.5 \times n$ | |
| AOA12F | $5+4.5 \times n$ | |
| AOR08G | 5 | $10 \times n$ |
| AOR16G | 5 | $10 \times n$ |
| AOR16H2 | 5 | $10 \times n$ |
| AAD04A | 5 | 130 |
| ADA02A | 6 | 120 |
| ADA04B | 5 | 130 |
| ACT01A | $170+0.3 \times \alpha$ | |
| ATI04A | 62.5 | 100 |
| ATI04B | 62.5 | 100 |

n: Number of the input and output points (for each module) which turn ON simultaneously

α : +5-V current (mA) output to the outside

- Add the sums of the columns A and B for the modules to be used. The sum is the required current.(Unit:mA)
- For each base unit, keep the sum of column A and the sum of column B to within 500 mA and 1,500 mA, respectively.

4.5 INTERFACE MODULE (AIF01A, AIF01B)

Details of the cables K1X, K2X and the terminator shown in the general connection diagram are as follows.

1) Cable K1X

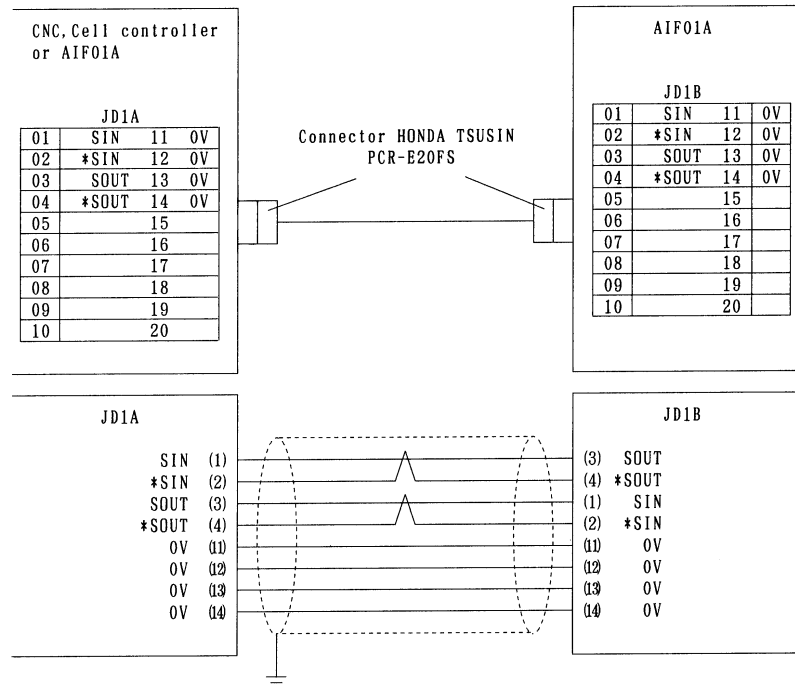

- a) Make sure to use twisted pair wires for signal SIN and *SIN, and signals SOUT and *SOUT.
 - i) Reconnected cable material: A66L-0001-0284#10P (twisted pair/shielded)
 - ii) Shielding wires should be connected with the grounding plate of the cabinet at the JD1A side using a cable clamp. (Refer to the CONNECTING MANUAL for the CNC and the cell controller.)
 - iii) Maximum cable length: 10 m
 - iv) Make sure not to connect to the connector spare pins.
 - v) In the following cases, make sure to use an optical I/O link adapter and an optical fiber cable. (See chapter 10)
 - When the cable is more than 10 meters long.
 - When the cable runs between different cabinets and there is no appropriate ground wire between the cabinets.
 - When there is concern that the cable is influenced by strong noise.
 - vi) When an optical I/O link adapter is used: Cable to be used between the interface module (AIF01A) and the optical I/O link adapter is dissimilar to this cable. (See chapter 10.)

2) Cable K2X

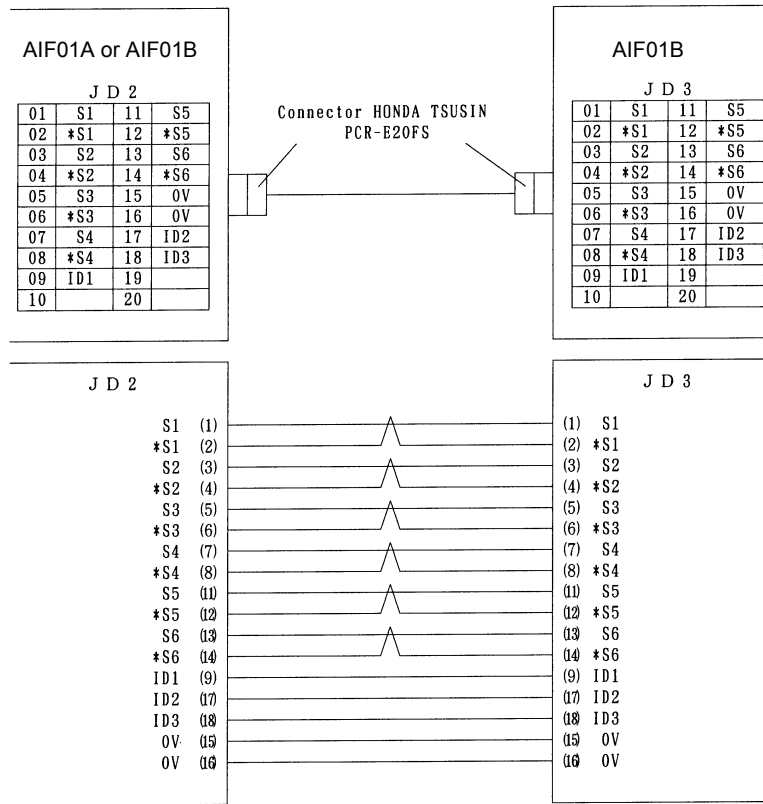

- Connect the signals with a same name.
- Make sure to use twisted pair wires for the following signals:
S1 and * S1, S2 and *S2, S3 and *S3
S4 and * S4, S5 and *S5, S6 and *S6
- Do not connect the pins No.10, No.19 and No.20 as they are used internally.
- Recommended cable material: A66L - 0001 - 0284#10P (twisted pair/shielded)
- Maximum cable length: 2m

3) Terminator TX

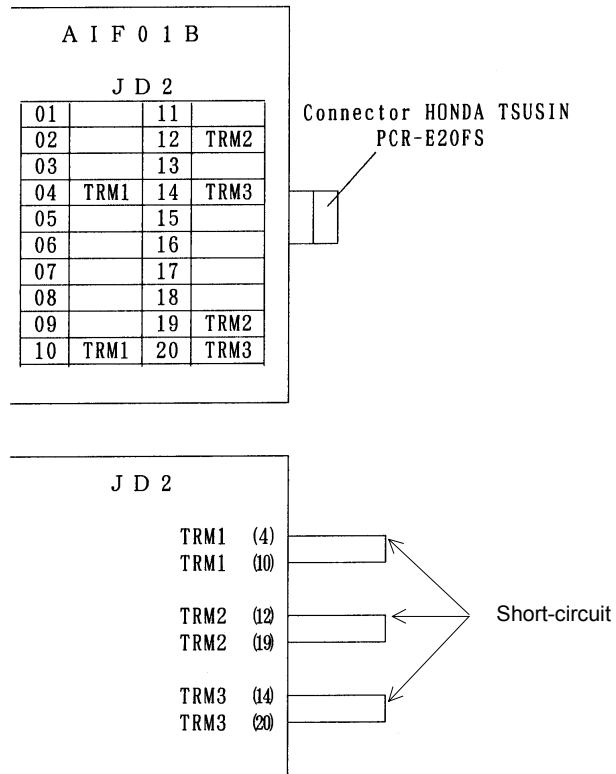

- Terminate the connector JD2 of the last AIF01B in a single group with the terminator. The connector need not be terminated when the AIF01B is not used.
- Short-circuit the TRM1s, the TRM2s and the TRM 3s one another respectively in a manner that a TRM1 is with another TRM1 and so on.

4.6 INTERFACE MODULE (AIF02C) CONNECTION

4.6.1 Overview

One interface module (AIF02C) can control communication with both I/O Unit-A and Unit-B, when it is connected to the FANUC I/O Link.

The following examples show a configuration in which two conventional separate interface modules, I/O Unit-A and I/O Unit-B, are used and a configuration in which the AIF02C is used.

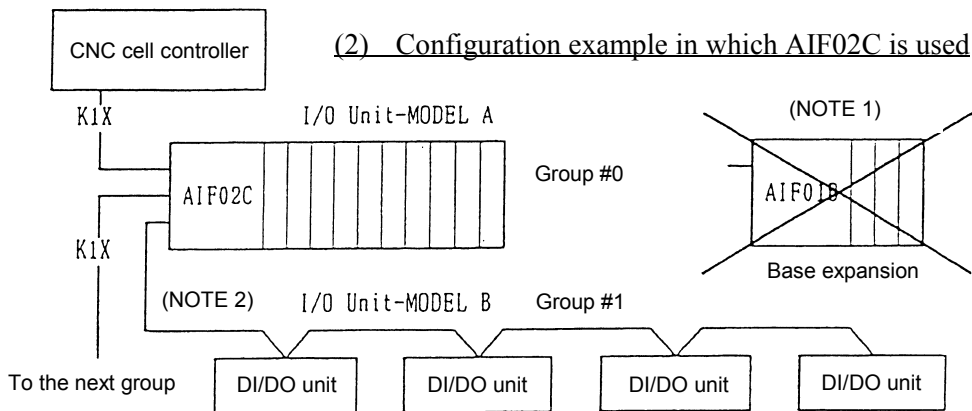
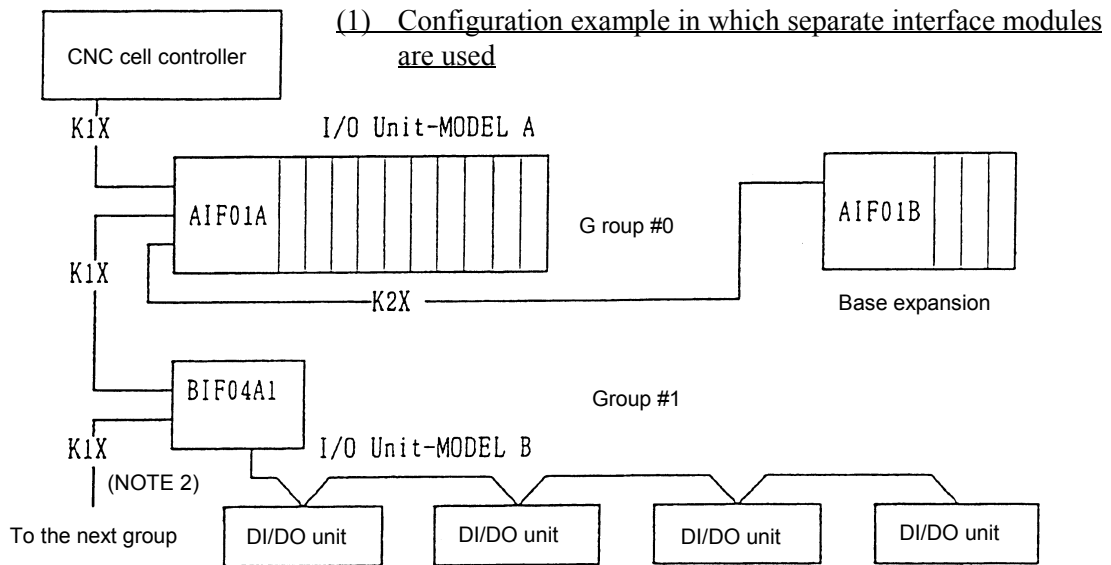

In this way, using the AIF02C eliminates the necessity for the interface unit (BIF04A1) for I/O Unit-B, which has conventionally been used separately; this configuration is suitable for a small I/O Unit-B system. Note the following points.

NOTES

- 1 The AIF02C cannot be used for base expansion.
- 2 The BIF04A1 can branch to a maximum of eight communication lines.
The AIF02C can branch only to a maximum of two distributed link cables.

4.6.2 Connection

(1) Connection diagram

[a] Configuration with two distributed link cables (note the setting of the terminating resistor.)

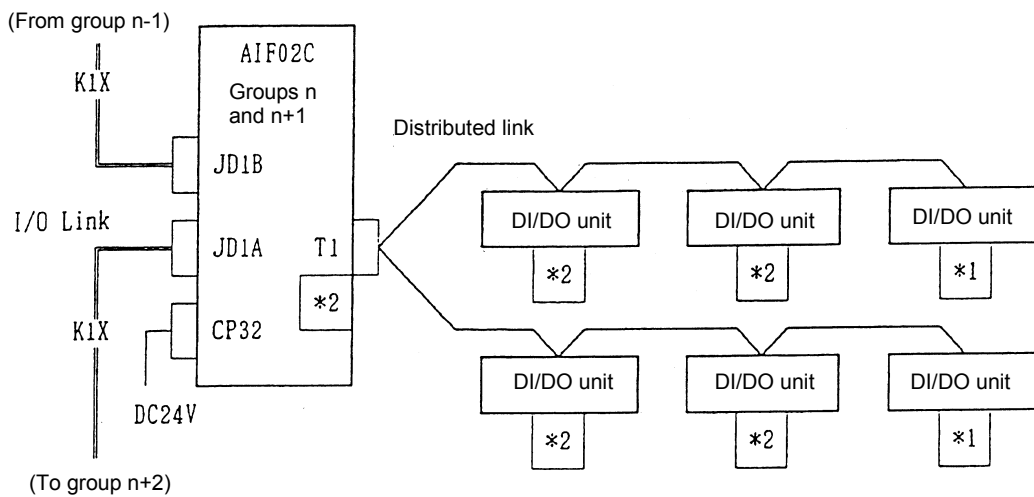

CAUTIONS

- 1 Set the terminating resistor DIP switch to ON
- 2 Set the terminating resistor DIP switch to OFF.

[b] Connection with one Distributed Link cable (note the setting

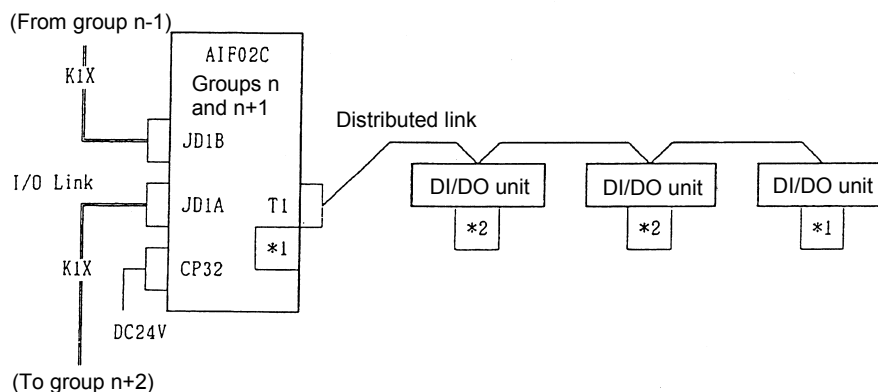

CAUTIONS

- 1 Set the terminating resistor DIP switch to ON.
- 2 Set the terminating resistor DIP switch to OFF.

(2) Connection with the I/O link

The AIF02C occupies two groups on the I/O link.

When groups #n and #n+1 are used, for example, the smaller-numbered group, #n, is assigned to the I/O Unit-A, and the larger-numbered group, #n+1, is assigned to the I/O Unit-B.

[a] Connection of the I/O link cable

Connect the I/O link cable from the previous group to JD1B. Connect JD1A to the I/O link cable leading to the next group. Use the K1X I/O link signal cable, the same I/O link signal cable type as that for the AIF01A.

[b] Number of occupied I/O points on the I/O link

The nominal number of occupied I/O points may differ from the actual number of I/O points. For the details of the number of I/O points occupied by the I/O Unit-B, refer to Section 4.2.1, "Number of points occupied on the interface unit I/O link," of the FANUC I/O Unit-B MODEL Connection Manual (B-62163E).

(3) Connection with the distributed link (I/O Unit-B)

[a] Number of distributed communication lines (I/O Unit-B)

"T1" can connect to two communication lines (twisted-pair wires).

So, it is possible to branch to up to two lines.

To branch to more lines, you should use the I/O Unit-B interface unit (BIF04A1), which enables branching to up to eight communication lines.

[b] Terminal board "T1," used for connection with the distributed link cable

The distributed link cable is connected to "T1."

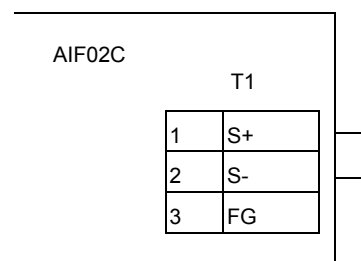

- ① Use twisted-pair wires as the distributed link cable.
- ② The distributed link cable is polarity-sensitive. Match the signal polarity of the AIF02C with that of the basic unit.
- ③ The terminal board has M3 screws with a terminal cover.

Refer to Section 4.3, "Connecting a Distributed Link," and Section 4.5.2, "Connecting the communications cable," of the FANUC I/O Unit-MODEL B Connection Manual (B-62163E) for details.

4.6.3 Setting with the DIP switch

In the AIF02C, distributed link settings can be made with the DIP switch on the back of the module.

The settings and corresponding signals are shown below.

| | | |
|---|------|----------|
| 1 | | } Unused |
| 2 | | |
| 3 | | |
| 4 | EDSP | |
| 5 | Q | |
| 6 | H | |
| 7 | URDY | |
| 8 | R | |

- (1) EDSP (error display method selection)
Normally, set EDSP to the ON position.
- (2) Q and H (communication speed setting)
Normally, set both Q and H to the OFF positions.
- (3) URDY (setting of the power on/off information for the unit)
Normally, set URDY to the OFF position.
- (4) R (terminating resistor setting)
The ON position means that a terminating resistor must be installed. The OFF position means that no terminating resistor need be installed.

When only one communication cable is connected to the AIF02C, terminate it and the basic unit at the end of the communication cable with a resistor.

When two communication cables are connected to the AIF02C, terminate the basic unit connected to the end of each communication cable with a resistor. Do not connect a terminating resistor to the AIF02C. (Refer to Section 4.6.2, "Connection.")

Refer to Section 5.1.1, "DIP switch setting," of the FANUC I/O Unit-MODEL B Connection Manual (B-62163E).

4.7 CONNECTING WITH I/O MODULES

From the point of view of an external connecting method, there are two types of I/O modules such as one with a terminal block and one with a connector.

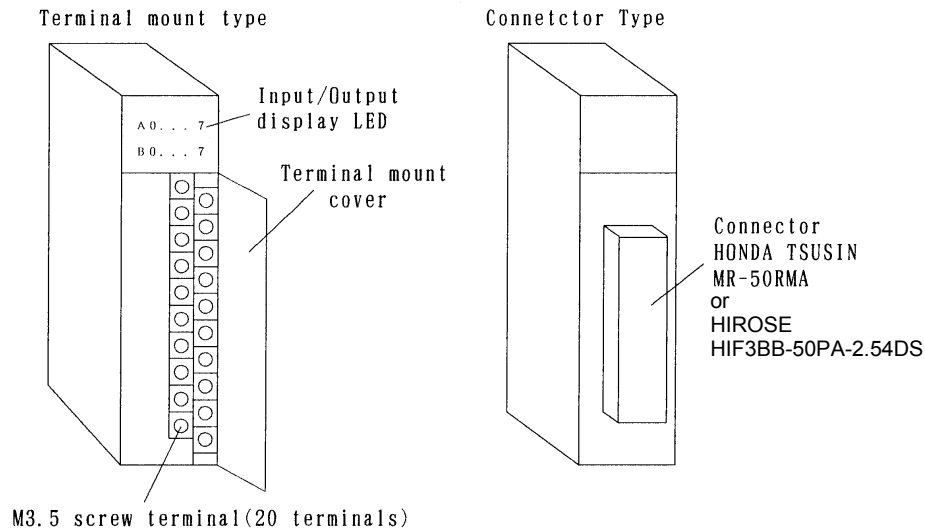

- 1) Connect with each module following the connection diagrams of sections 4.2 and 5.3.
- 2) The terminal block is a removable type.

[Dismounting the terminal block]

- ① Open the cover of the terminal block.
- ② Push up the latch at the top of the terminal block.
- ③ Drag out the tab at the top of the terminal block and pull it out. The terminal block will be removed from the module.

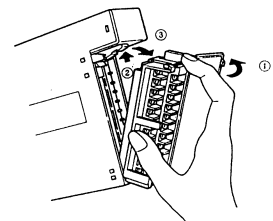

[Mounting the terminal block]

- ① Insert the protruding portion at the bottom of the terminal block in the groove of the module side.
- ② Push the terminal block using the engaging point of the protruding portion and the groove as an axis and mount it in the module firmly.
- ③ Open the cover of the terminal block and check to make sure the latch at the top of the terminal block is firmly set.

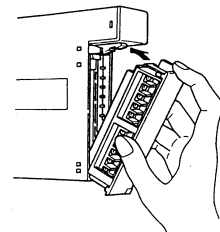

3) Cautionary points when wiring terminal block type

- Wiring material : AWG22 to 18 (0.3 to 0.75 mm²)
A wire as this as possible is recommended.
- Crimp style terminal : M3.5
Crimp style terminal with no insulation sleeve and a short distance "A", as illustrated in the drawing below, is recommended.

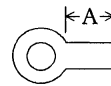

| | |
|----------------|----------------|
| DAIDO TANSHI | 1.25-S3.5 |
| NICHIFU TANSHI | 1.25-3.5S etc. |

- Mark tube : Use a short mark tube as possible and cover crimped part with the mark tube.

5

DIGITAL INPUT/OUTPUT MODULES

5.1 LIST OF MODULES

Digital input modules

| Input type | module name | Rated voltage | Rated current | Polarity | Response time | Points | External connection | LED display |
|------------------------------|-------------|---------------|------------------|----------|-------------------------------|---------|---------------------|--------------|
| Non-insulation type DC input | AID32A1 | 24VDC | 7.5 mA | Both | Maximum 20 ms | 32 | Connector A | not provided |
| | AID32B1 | 24VDC | 7.5 mA | Both | Maximum 2 ms | 32 | Connector A | not provided |
| | AID32H1 | 24VDC | 7.5 mA | Both | Maximum 2 ms Maximum 20 ms | 8 24 | Connector A | not provided |
| Insulation type DC input | AID16C | 24VDC | 7.5 mA | NEG | Maximum 20 ms | 16 | Terminal block | provided |
| | AID16K | 24VDC | 7.5 mA | NEG | Maximum 2 ms | 16 | Terminal block | provided |
| | AID16D | 24VDC | 7.5 mA | POS | Maximum 20 ms | 16 | Terminal block | provided |
| | AID16L | 24VDC | 7.5 mA | POS | Maximum 2 ms | 16 | Terminal block | provided |
| | AID32E1 | 24VDC | 7.5 mA | Both | Maximum 20 ms | 32 | Connector A | not provided |
| | AID32E2 | 24VDC | 7.5 mA | Both | Maximum 20 ms | 32 | Connector B | not provided |
| | AID32F1 | 24VDC | 7.5 mA | Both | Maximum 2 ms | 32 | Connector A | not provided |
| | AID32F2 | 24VDC | 7.5 mA | Both | Maximum 2 ms | 32 | Connector B | not provided |
| AC input | AIA16G | 100 to 120VAC | 10.5 mA (120VAC) | | ON Max 35ms OFF Max 45ms | 16 | Terminal block | provided |

NOTE

1 Polarity

Negative : 0 V common (current source type) Regard to be ON when input is at Low level.

Positive : 24 V common (current sink type) Regard to be ON when input is High level.

2 Connector A : HONDA MR Connector

Connector B : Flat Cable Connector

3 For the details of the specifications for each module, refer to the section 5.3.

Digital output modules

| Output type | Module name | Rated voltage | Maximum current | Polarity | Points | Points/common | External connection | LED display | Fuse |
|-------------------------------|-------------|--------------------------|-----------------|----------|--------|---------------|---------------------|--------------|--------------|
| Non-insulation type DC output | AOD32A1 | 5 to 24VDC | 0.3A | NEG | 32 | 8 | Connector A | not provided | not provided |
| Insulation type DC output | AOD08C | 12 to 24VDC | 2A | NEG | 8 | 8 | Terminal block | provided | provided |
| | AOD08D | | 2A | POS | 8 | 8 | Terminal block | provided | provided |
| | AOD16C | | 0.5A | NEG | 16 | 8 | Terminal block | provided | not provided |
| | AOD16D | | 0.5A | POS | 16 | 8 | Terminal block | provided | not provided |
| | AOD32C1 | | 0.3A | NEG | 32 | 8 | Connector A | not provided | not provided |
| | AOD32C2 | | 0.3A | NEG | 32 | 8 | Connector B | not provided | not provided |
| | AOD32D1 | | 0.3A | POS | 32 | 8 | Connector A | not provided | not provided |
| | AOD32D2 | | 0.3A | POS | 32 | 8 | Connector B | not provided | not provided |
| AC output | AOA05E | 100 to 240VAC | 2A | - | 5 | 1 | Terminal block | provided | provided |
| | AOA08E | | 1A | - | 8 | 4 | Terminal block | provided | provided |
| | AOA12F | 100 to 120VAC | 0.5A | - | 12 | 6 | Terminal block | provided | provided |
| RELAY output | AOR08G | Maximum 250VAC/ 30VDC | 4A | - | 8 | 1 | Terminal block | provided | not provided |
| | AOR16G | | 2A | - | 16 | 4 | Terminal block | provided | not provided |
| | AOR16H2 | 30VDC | 2A | - | 16 | 4 | Connector B | provided | not provided |

NOTE

1 Polarity

Negative : 0 V common (current sink type) Output is at Low level when ON.

Positive : 24 V common (current source type) Output is at High level when ON.

2 Connector A : HONDA MR Connector

Connector B : Flat Cable Connector

3 For the details of the specifications for each module, refer to the section 5.3.

4 The maximum current of the DC output module includes the permissible rush current.

5.2 CORRESPONDENCE BETWEEN I/O SIGNALS AND ADDRESSES IN A MODULE

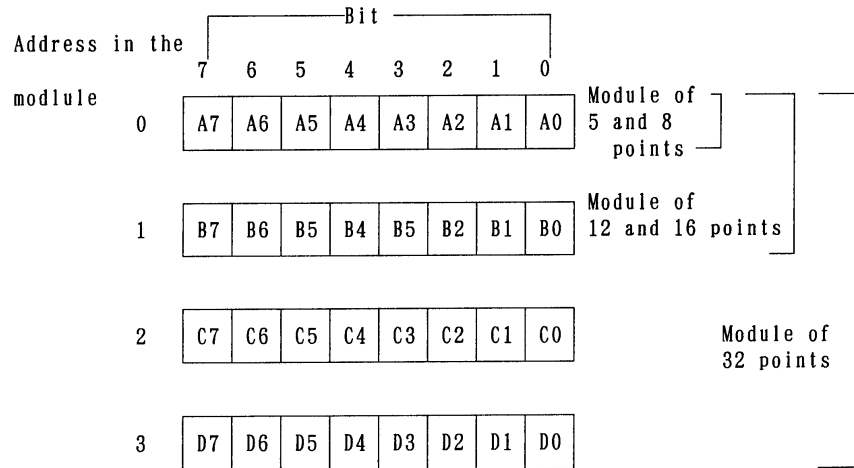

Addresses in a module are addresses defined for each module. They are relative addresses in a module with the beginning address in the module as 0. Real addresses viewed from the sequence program of the PMC are set by the programmer.

For input modules, an input signal becomes "1" when the contact point connected with the input is turned ON. On the other hand, for output modules, an output contact point (or transistor) is turned ON when the output signal is "1."

5.3 SPECIFICATION FOR EACH MODULE

Specifications for each I/O module are shown in the following pages.

- (1) Input module AID32A1
- (2) Input module AID32B1
- (3) Input module AID32H1
- (4) Input module AID16C
- (5) Input module AID16K
- (6) Input module AID16D
- (7) Input module AID16L
- (8) Input module AID32E1
- (9) Input module AID32E2
- (10) Input module AID32F1
- (11) Input module AID32F2
- (12) Input module AIA16G
- (13) Output module AOD32A1
- (14) Output module AOD08C
- (15) Output module AOD08D
- (16) Output module AOD16C
- (17) Output module AOD16D
- (18) Output module AOD32C1
- (19) Output module AOD32C2
- (20) Output module AOD32D1
- (21) Output module AOD32D2
- (22) Output module AOA05E
- (23) Output module AOA08E
- (24) Output module AOA12F
- (25) Output module AOR08G
- (26) Output module AOR16G
- (27) Output module AOR16H2

(1) Input module AID32A1 (Non-insulation type)

| Item | | Specifications | |
|-----------------------------------|--------|-----------------------------------|--------------------------------------------------------------------------------------------------------------------------------------------------|
| Points/module | | 32 points | |
| Points/common | | 16 points/common | |
| Sink/source current | | Both directions | |
| Input voltage | | 24VDC +10%, -20% | |
| Input current | | 7.5mA (average) | |
| ON voltage, current | | Min. 18VDC, min. 6mA | |
| OFF voltage, current | | Max. 6VDC, max. 1.5mA | |
| Response time | OFF ON | Max.20ms | This is the value from input to output in the module. The actual value is determined by adding it to the scanning time depending on each system. |
| | ON OFF | Max.20ms | |
| Input display | | Not provided | |
| External connection | | Connector (HONDA TSUSIN MR-50RMA) | |
| Terminal connection and circuitry | | | |

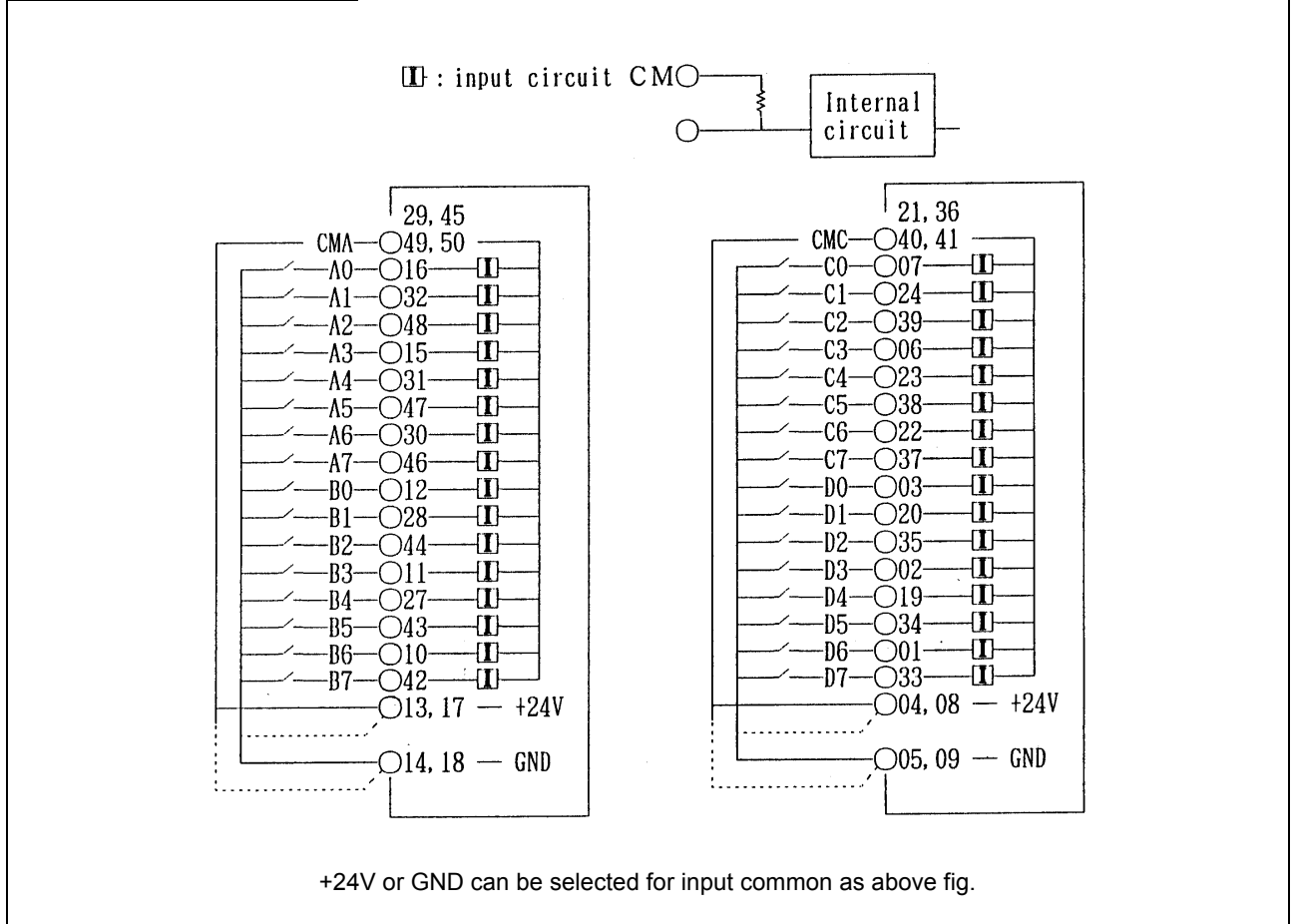

NOTE
 1 Make sure to connect all common (CMA, CMC) pins.
 2 This module outputs +24 V on pins 13, 17, 04, and 08.

(2) Input module AID32B1 (Non-insulation type)

| Item | | Specifications | |
|-----------------------------------|--------|-----------------------------------|--------------------------------------------------------------------------------------------------------------------------------------------------|
| Points/module | | 32 points | |
| Points/common | | 16 points/common | |
| Sink/source current | | Both directions | |
| Input voltage | | 24VDC +10%, -20% | |
| Input current | | 7.5mA (average) | |
| ON voltage, current | | Min. 18VDC, min. 6mA | |
| OFF voltage, current | | Max. 6VDC, max. 1.5mA | |
| Response time | OFF ON | Max.2ms | This is the value from input to output in the module. The actual value is determined by adding it to the scanning time depending on each system. |
| | ON OFF | Max.2ms | |
| Input display | | Not provided | |
| External connection | | Connector (HONDA TSUSIN MR-50RMA) | |
| Terminal connection and circuitry | | | |

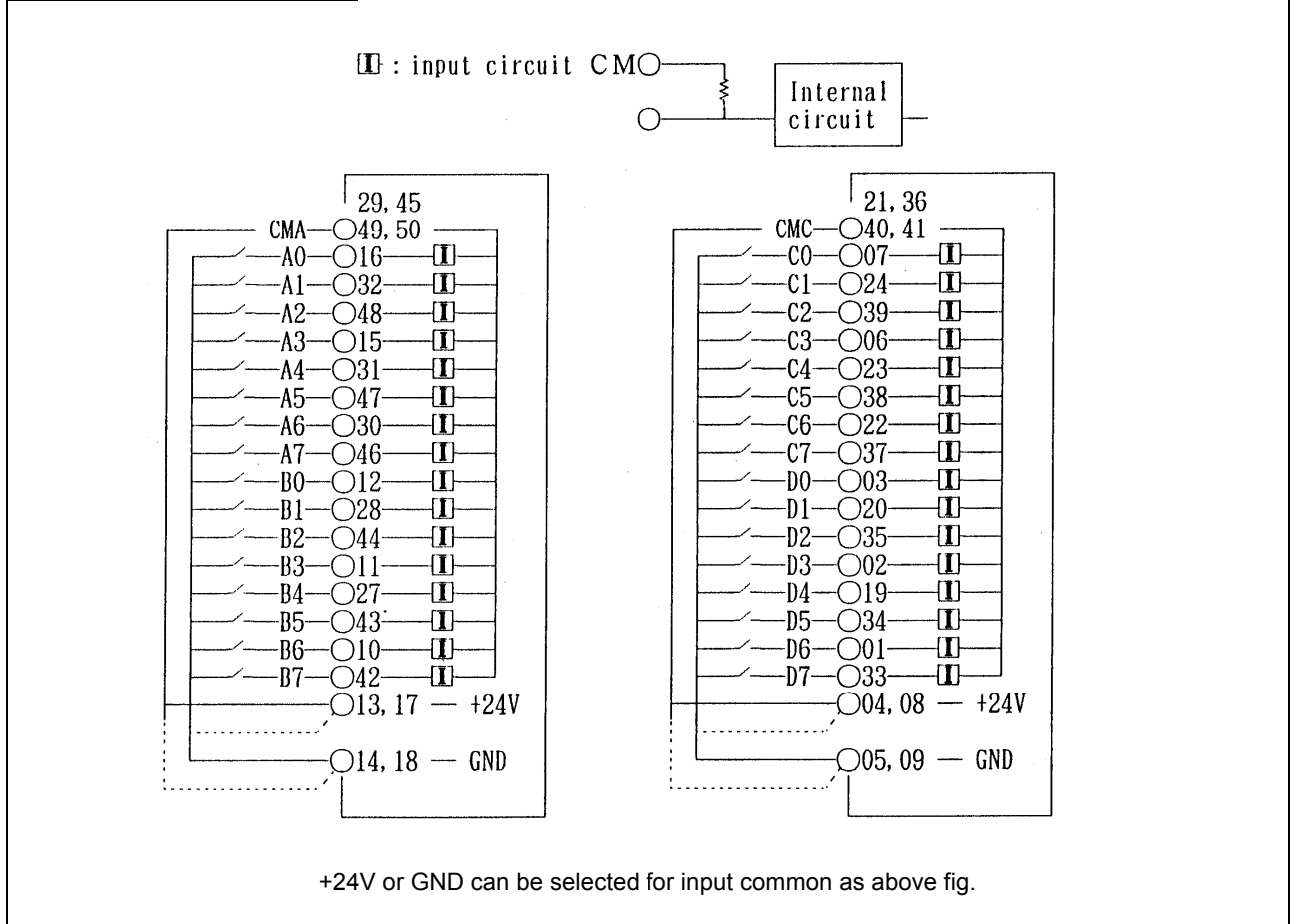

NOTE
 1 Make sure to connect all common (CMA, CMC) pins.
 2 This module outputs +24 V on pins 13, 17, 04, and 08.

(3) Input module AID32H1

| Item | | Specifications | |
|----------------------|--------|-------------------------------------------|--------------------------------------------------------------------------------------------------------------------------------------------------|
| Points/module | | 32 points | |
| Points/common | | 16 points/common | |
| Sink/source current | | Both directions | |
| Input voltage | | 24VDC +10%, -20% | |
| Input current | | 7.5mA (average) | |
| ON voltage, current | | Min. 18VDC, min. 6mA | |
| OFF voltage, current | | Max. 6VDC, max. 1.5mA | |
| Response time | OFF ON | Max.2ms (A0 to A7) Max.20ms (B0 to D7) | This is the value from input to output in the module. The actual value is determined by adding it to the scanning time depending on each system. |
| | ON OFF | Max.2ms (A0 to A7) Max.20ms (B0 to D7) | |
| Input display | | Not provided | |
| External connection | | Connector (HONDA TSUSIN MR-50RMA) | |

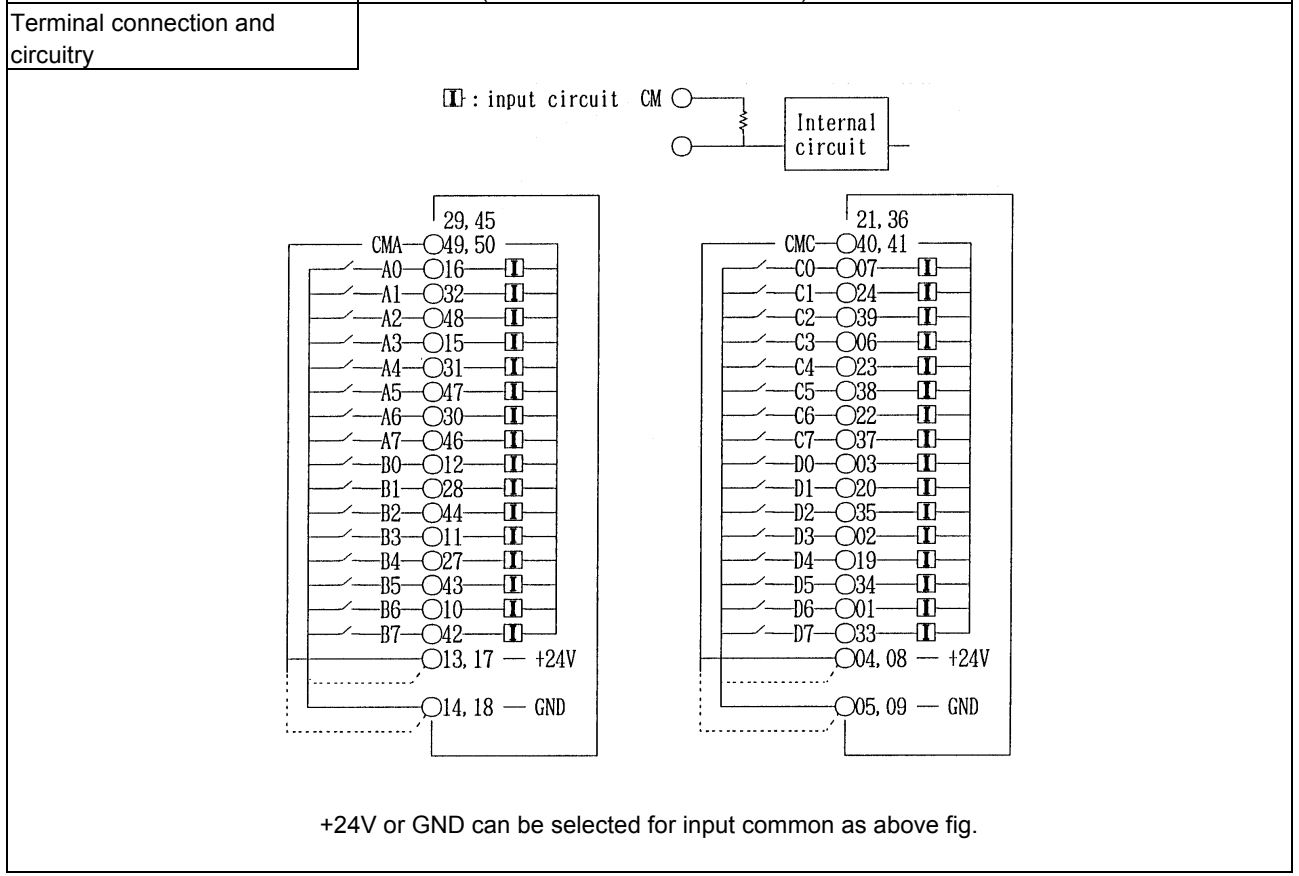

NOTE
 1 Make sure to connect all common (CMA, CMC) pins.
 2 This module outputs +24 V on pins 13, 17, 04, and 08.

(4) Input module AID16C

| Item | | Specifications | |
|----------------------|--------|--------------------------------------------------------------|--------------------------------------------------------------------------------------------------------------------------------------------------|
| Points/module | | 16 points | |
| Points/common | | 16 points/common | |
| Sink/source current | | Source current type | |
| Input voltage | | 24VDC +10%, -20% | |
| Input current | | 7.5mA (average) | |
| ON voltage, current | | Min. 15VDC, min. 4mA | |
| OFF voltage, current | | Max. 5VDC, max. 1.5mA | |
| Response time | OFF ON | Max.20ms | This is the value from input to output in the module. The actual value is determined by adding it to the scanning time depending on each system. |
| | ON OFF | Max.20ms | |
| Input display | | LED display | |
| External connection | | Terminal block connector (20 terminals, M3.5 screw terminal) | |

Terminal connection and circuitry

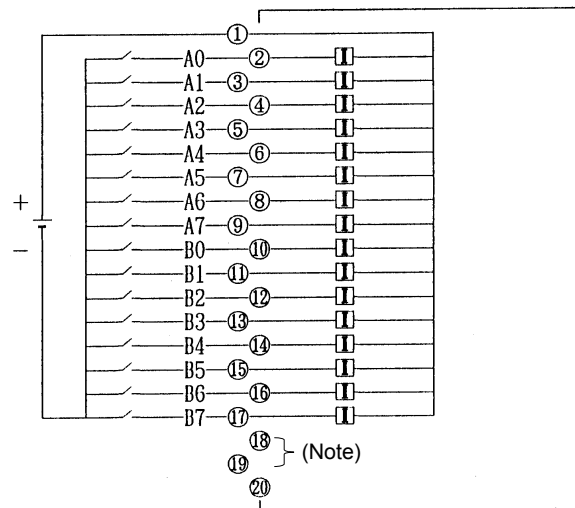

□: input circuit

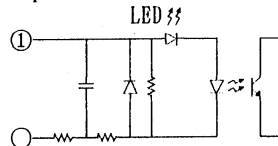

NOTE
 Pins 18 and 19 are for factory use only.
 Do not connect any wire to them

(5) Input module AID16K

| Item | | Specifications | |
|-----------------------------------|--------|--------------------------------------------------------------|--------------------------------------------------------------------------------------------------------------------------------------------------|
| Points/module | | 16 points | |
| Points/common | | 16 points/common | |
| Sink/source current | | Source current type | |
| Input voltage | | 24VDC +10%, -20% | |
| Input current | | 7.5mA (average) | |
| ON voltage, current | | Min. 15VDC, min. 4mA | |
| OFF voltage, current | | Max. 5VDC, max. 1.5mA | |
| Response time | OFF ON | Max.2ms | This is the value from input to output in the module. The actual value is determined by adding it to the scanning time depending on each system. |
| | ON OFF | Max.2ms | |
| Input display | | LED display | |
| External connection | | Terminal block connector (20 terminals, M3.5 screw terminal) | |
| Terminal connection and circuitry | | | |

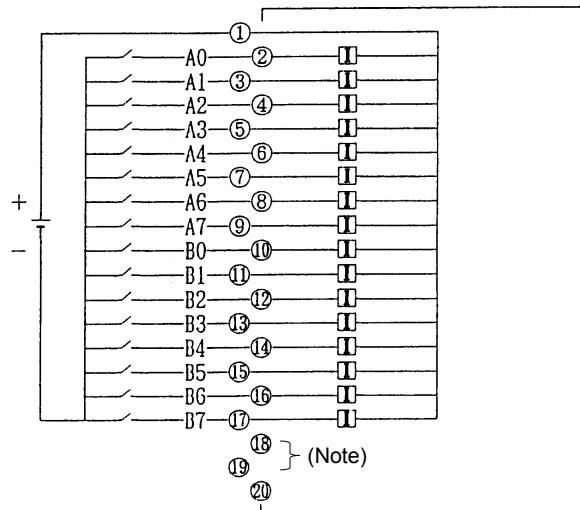

□ : input circuit

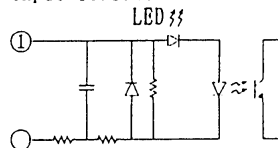

NOTE
 Pins 18 and 19 are for factory use only.
 Do not connect any wire to them

(6) Input module AID16D

| Item | | Specifications | |
|----------------------|--------|--------------------------------------------------------------|--------------------------------------------------------------------------------------------------------------------------------------------------|
| Points/module | | 32 points | |
| Points/common | | 16 points/common | |
| Sink/source current | | Sink current type | |
| Input voltage | | 24VDC +10%, -20% | |
| Input current | | 7.5mA (average) | |
| ON voltage, current | | Min. 15VDC, min. 4mA | |
| OFF voltage, current | | Max. 5VDC, max. 1.5mA | |
| Response time | OFF ON | Max.20ms | This is the value from input to output in the module. The actual value is determined by adding it to the scanning time depending on each system. |
| | ON OFF | Max.20ms | |
| Input display | | LED display | |
| External connection | | Terminal block connector (20 terminals, M3.5 screw terminal) | |

Terminal connection and circuitry

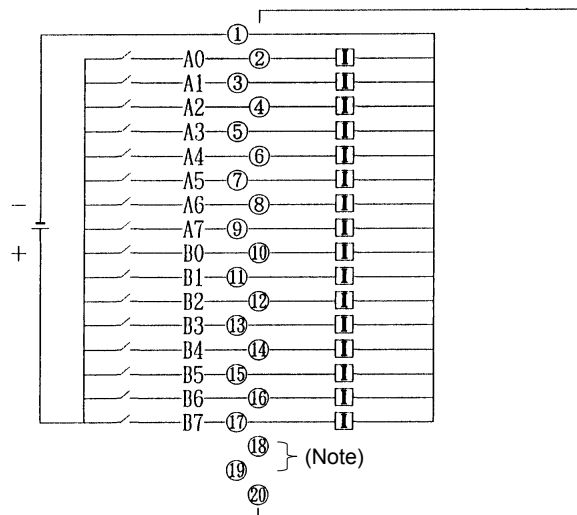

□ : input circuit

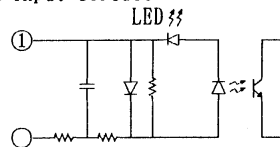

NOTE
 Pins 18 and 19 are for factory use only.
 Do not connect any wire to them

(7) Input module AID16L

| Item | | Specifications | |
|-----------------------------------|--------|--------------------------------------------------------------|--------------------------------------------------------------------------------------------------------------------------------------------------|
| Points/module | | 16 points | |
| Points/common | | 16 points/common | |
| Sink/source current | | Source current type | |
| Input voltage | | 24VDC +10%, -20% | |
| Input current | | 7.5mA (average) | |
| ON voltage, current | | Min. 15VDC, min. 4mA | |
| OFF voltage, current | | Max. 5VDC, max. 1.5mA | |
| Response time | OFF ON | Max.2ms | This is the value from input to output in the module. The actual value is determined by adding it to the scanning time depending on each system. |
| | ON OFF | Max.2ms | |
| Input display | | LED display | |
| External connection | | Terminal block connector (20 terminals, M3.5 screw terminal) | |
| Terminal connection and circuitry | | | |

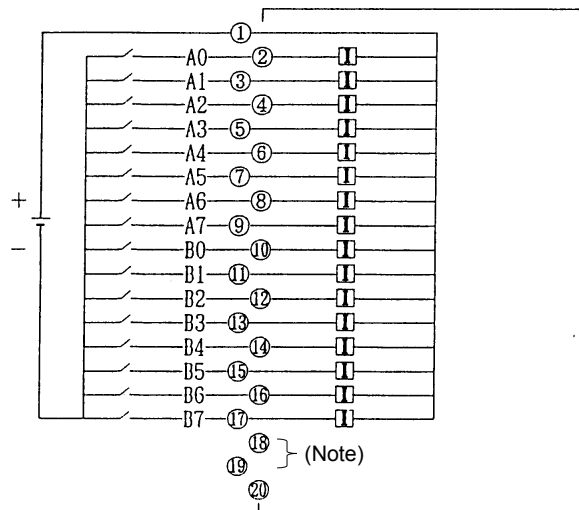

□: input circuit

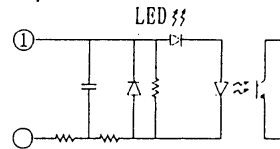

NOTE
 Pins 18 and 19 are for factory use only.
 Do not connect any wire to them

(8) Input module AID32E1

| Item | | Specifications | |
|----------------------|--------|-----------------------------------|--------------------------------------------------------------------------------------------------------------------------------------------------|
| Points/module | | 32 points | |
| Points/common | | 8 points/common | |
| Sink/source current | | Both directions | |
| Input voltage | | 24VDC +10%, -20% | |
| Input current | | 7.5mA (average) | |
| ON voltage, current | | Min. 15VDC, min. 4.5mA | |
| OFF voltage, current | | Max. 6VDC, max. 2mA | |
| Response time | OFF ON | Max.20ms | This is the value from input to output in the module. The actual value is determined by adding it to the scanning time depending on each system. |
| | ON OFF | Max.20ms | |
| Input display | | Not provided | |
| External connection | | Connector (HONDA TSUSIN MR-50RMA) | |

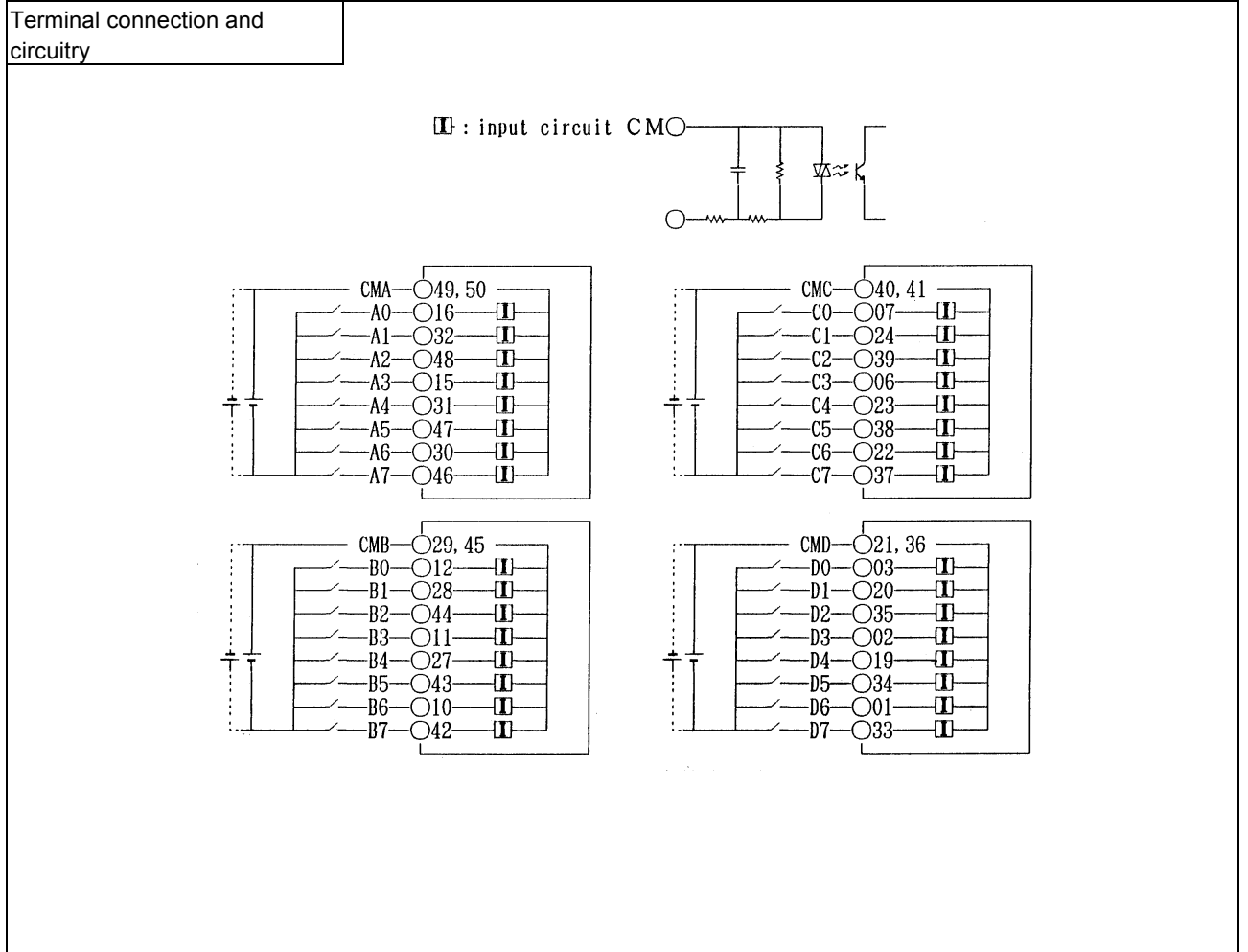

(9) Input module AID32E2

| Item | | Specifications | |
|----------------------|--------|--------------------------------------------------------------------------------|--------------------------------------------------------------------------------------------------------------------------------------------------|
| Points/module | | 32 points | |
| Points/common | | 8 points/common | |
| Sink/source current | | Both directions | |
| Input voltage | | 24VDC +10%, -20% | |
| Input current | | 7.5mA (average) | |
| ON voltage, current | | Min. 15VDC, min. 4.5mA | |
| OFF voltage, current | | Max. 6VDC, max. 2mA | |
| Response time | OFF ON | Max.20ms | This is the value from input to output in the module. The actual value is determined by adding it to the scanning time depending on each system. |
| | ON OFF | Max.20ms | |
| Input display | | Not provided | |
| External connection | | Connector (HIROSE ELECTRIC HIF3BB-50PA-2.54DS in accordance with MIL standard) | |

Terminal connection and circuitry

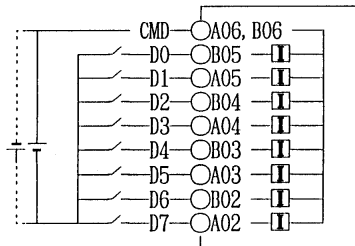
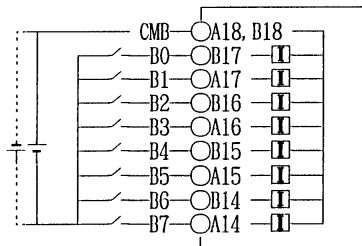
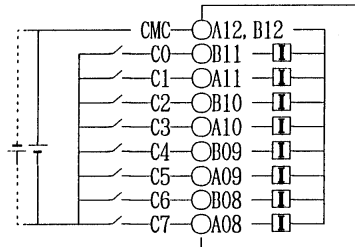
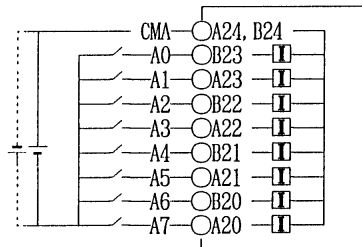
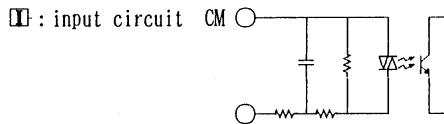

(10) Input module AID32F1

| Item | | Specifications | |
|-----------------------------------|--------|-----------------------------------|--------------------------------------------------------------------------------------------------------------------------------------------------|
| Points/module | | 32 points | |
| Points/common | | 8 points/common | |
| Sink/source current | | Both directions | |
| Input voltage | | 24VDC +10%, -20% | |
| Input current | | 7.5mA (average) | |
| ON voltage, current | | Min. 15VDC, min. 4.5mA | |
| OFF voltage, current | | Max. 6VDC, max. 2mA | |
| Response time | OFF ON | Max.2ms | This is the value from input to output in the module. The actual value is determined by adding it to the scanning time depending on each system. |
| | ON OFF | Max.2ms | |
| Input display | | Not provided | |
| External connection | | Connector (HONDA TSUSIN MR-50RMA) | |
| Terminal connection and circuitry | | | |

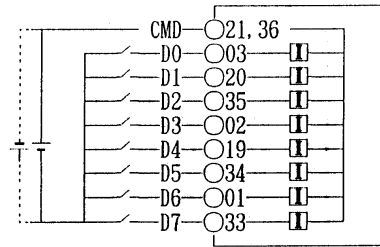
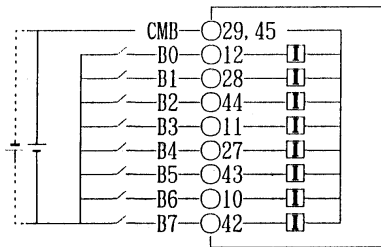
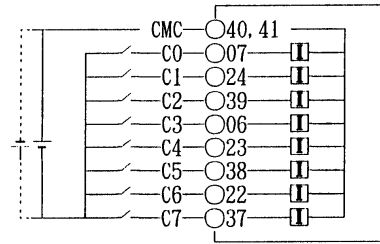
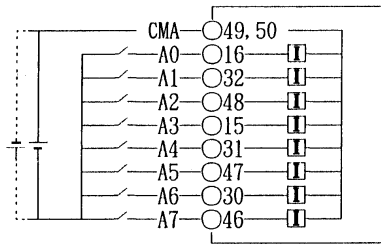
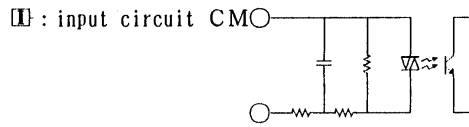

(11) Input module AID32F2

| Item | | Specifications | |
|----------------------|--------|--------------------------------------------------------------------------------|--------------------------------------------------------------------------------------------------------------------------------------------------|
| Points/module | | 32 points | |
| Points/common | | 8 points/common | |
| Sink/source current | | Both directions | |
| Input voltage | | 24VDC +10%, -20% | |
| Input current | | 7.5mA (average) | |
| ON voltage, current | | Min. 15VDC, min. 4.5mA | |
| OFF voltage, current | | Max. 6VDC, max. 2mA | |
| Response time | OFF ON | Max.2ms | This is the value from input to output in the module. The actual value is determined by adding it to the scanning time depending on each system. |
| | ON OFF | Max.2ms | |
| Input display | | Not provided | |
| External connection | | Connector (HIROSE ELECTRIC HIF3BB-50PA-2.54DS in accordance with MIL standard) | |

Terminal connection and circuitry

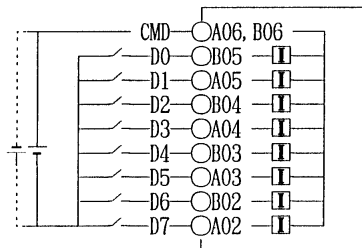
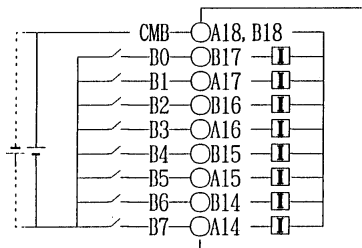
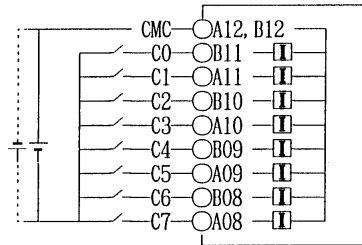
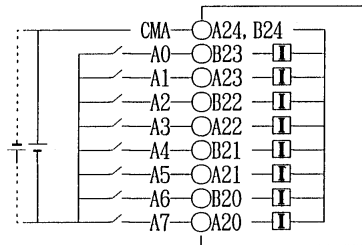
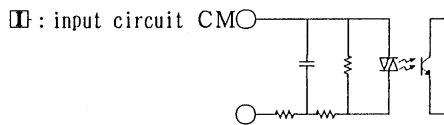

(12) Input module AIA16G

| Item | | Specifications | |
|-----------------------------------|--------|--------------------------------------------------------------|--------------------------------------------------------------------------------------------------------------------------------------------------|
| Points/module | | 16 points | |
| Points/common | | 16 points/common | |
| Sink/source current | | 100 to 115VAC ±15% | |
| Input voltage | | 132Vrms, 50/60 Hz | |
| Input current | | 10.55mArms (120VAC, 50Hz) | |
| ON voltage, current | | Min. 74Vrms, min. 6mArms | |
| OFF voltage, current | | Max. 20Vrms, max. 2.2mArms | |
| Response time | OFF ON | Max.35ms | This is the value from input to output in the module. The actual value is determined by adding it to the scanning time depending on each system. |
| | ON OFF | Max.45ms | |
| Input display | | LED display | |
| External connection | | Terminal block connector (20 terminals, M3.5 screw terminal) | |
| Common | | 16 points/common | |
| Terminal connection and circuitry | | <p>□ : input circuit</p> | |

(14) Output module AOD08C

| Item | | Specifications | |
|-----------------------------------|--------|----------------------------------------------------------------------------------------------------------------------------------------------------------------------------------------------------------------------------------------------------------------------------------------------------------------------------------------------------------------------------------------------------------------------------------------------------------------------------------------------------------------------------------------------------------------------------------------------------------------------------------|--------------------------------------------------------------------------------------------------------------------------------------------------|
| Points/module | | 8 points | |
| Points/common | | 8 points/common | |
| Sink/source current | | Sink current type | |
| Rated load voltage | | 12 to 24VDC +20%, -15% | |
| Maximum load current | | 2A (however 4A/fuse) | |
| Maximum voltage drop when ON | | 0.8V (load current ×0.4Ω) | |
| Maximum leak current when OFF | | 0.1mA | |
| Response time | OFF ON | Max.2ms | This is the value from input to output in the module. The actual value is determined by adding it to the scanning time depending on each system. |
| | ON OFF | Max.2ms | |
| Input display | | LED display | |
| External connection | | Terminal block connector (20 terminals, M3.5 screw terminal) | |
| Fuse | | 5A, 1 piece for each output A0-A3 and A4-A7. | |
| Terminal connection and circuitry | | <p>The diagram illustrates the internal circuitry of the AOD08C output module. It features 20 terminals labeled 1 through 20. Terminals 1 and 2 are connected to a power supply (+ and -). Terminals 3 through 10 are connected to input LEDs labeled A0 through A3. Terminals 11 through 18 are connected to input LEDs labeled A4 through A7. Terminals 19 and 20 are connected to a common output circuit. A fuse is connected between terminals 19 and 20. The output circuit includes an internal circuit block and an LED. A legend indicates that the symbol for the output circuit is a square with a circle inside.</p> | |

(15) Output module AOD08D

| Item | | Specifications | |
|-----------------------------------|--------|--------------------------------------------------------------|--------------------------------------------------------------------------------------------------------------------------------------------------|
| Points/module | | 8 points | |
| Points/common | | 8 points/common | |
| Sink/source current | | Source current type | |
| Rated load voltage | | 12 to 24VDC +20%, -15% | |
| Maximum load current | | 2A (however 4A/fuse) | |
| Limit of load | | Refer to load derating curve (Fig. 5.3(a)) | |
| Maximum voltage drop when ON | | 1.2V (load current \times 0.6 Ω) | |
| Maximum leak current when OFF | | 0.1mA | |
| Response Time | OFF ON | Max.2ms | This is the value from input to output in the module. The actual value is determined by adding it to the scanning time depending on each system. |
| | ON OFF | Max.2ms | |
| Output display | | LED display | |
| External connection | | Terminal block connector (20 terminals, M3.5 screw terminal) | |
| Fuse | | 5A, 1 piece for each output A0-A3 and A4-A7. | |
| Terminal connection and circuitry | | | |

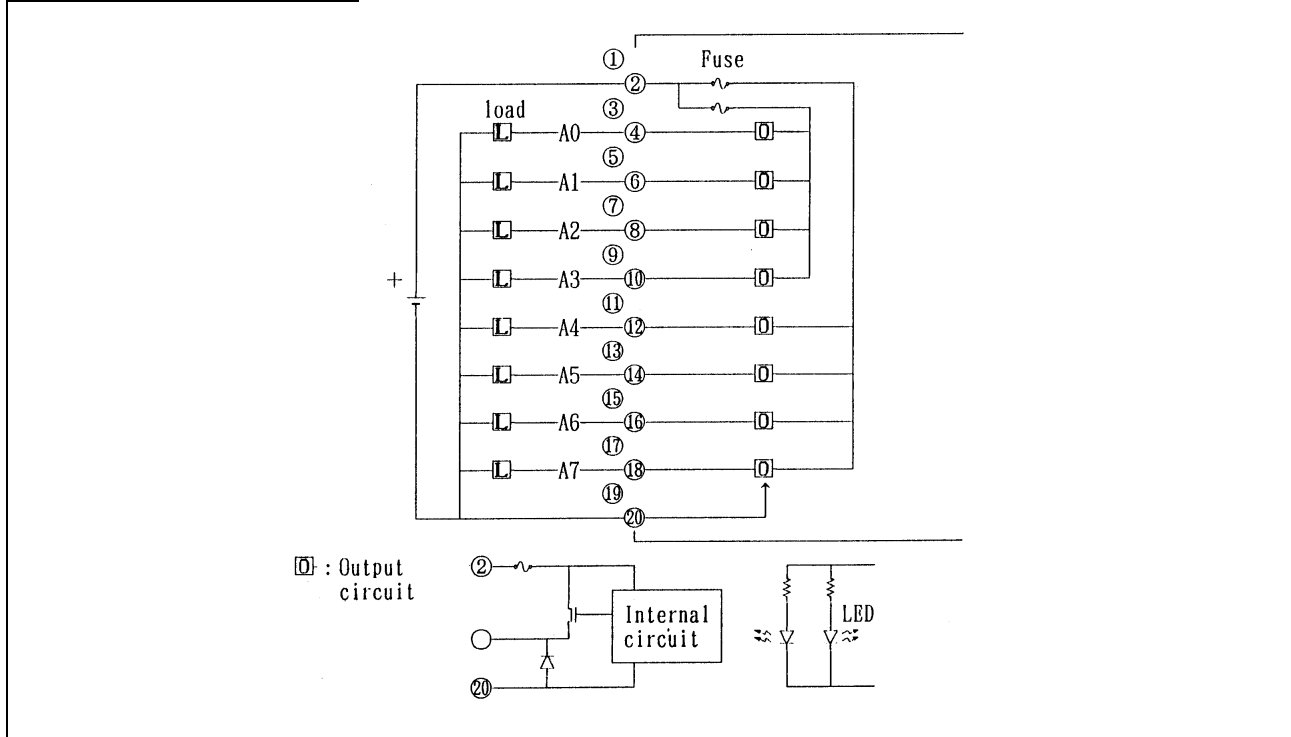

(16) Output module AOD16C

| Item | | Specifications | |
|-------------------------------|--------|--------------------------------------------------------------|--------------------------------------------------------------------------------------------------------------------------------------------------|
| Points/module | | 16 points | |
| Points/common | | 8 points/common | |
| Sink/source current | | Sink current type | |
| Rated load voltage | | 12 to 24VDC +20%, -15% | |
| Maximum load current | | 0.5A (however 2A/common) | |
| Maximum voltage drop when ON | | 0.7V (load current \times 1.4 Ω) | |
| Maximum leak current when OFF | | 0.1Ma | |
| Response time | OFF ON | Max.2ms | This is the value from input to output in the module. The actual value is determined by adding it to the scanning time depending on each system. |
| | ON OFF | Max.2ms | |
| Output display | | LED display | |
| External connection | | Terminal block connector (20 terminals, M3.5 screw terminal) | |

Terminal connection and circuitry

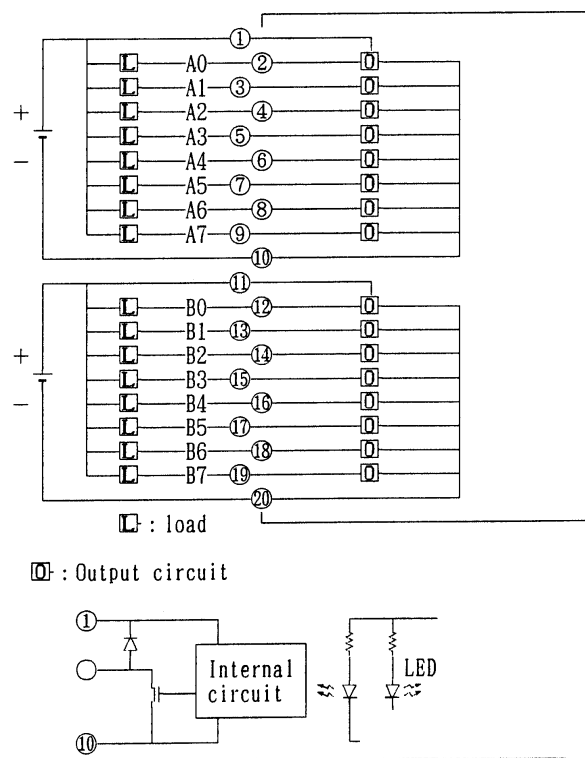

(17) Output module AOD16D

| Item | | Specifications | |
|-----------------------------------|--------|--------------------------------------------------------------|--------------------------------------------------------------------------------------------------------------------------------------------------|
| Points/module | | 16 points | |
| Points/common | | 8 points/common | |
| Sink/source current | | Source current type | |
| Rated load voltage | | 12 to 24VDC +20%, -15% | |
| Maximum load current | | 0.5A (however 2A/common) | |
| Maximum voltage drop when ON | | 0.7V (load current ×1.4Ω) | |
| Maximum leak current when OFF | | 0.1mA | |
| Response time | OFF ON | Max.2ms | This is the value from input to output in the module. The actual value is determined by adding it to the scanning time depending on each system. |
| | ON OFF | Max.2ms | |
| Output display | | LED display | |
| External connection | | Terminal block connector (20 terminals, M3.5 screw terminal) | |
| Terminal connection and circuitry | | <p>□ : load</p> <p>□ : output circuit</p> | |

(18) Output module AOD32C1

| Item | | Specifications |
|-------------------------------|--------|---------------------------------------------|
| Points/module | | 32 points |
| Points/common | | 8 points/common |
| Sink/source current | | Sink current type |
| Rated load voltage | | 12 to 24VDC +20%, -15% |
| Maximum load current | | 0.3A (however 2A/common) |
| Maximum voltage drop when ON | | 0.24V (load current \times 0.8 Ω) |
| Maximum leak current when OFF | | 0.1mA |
| Response time | OFF ON | Max.2ms |
| | ON OFF | Max.2ms |
| Output display | | Not provided |
| External connection | | Connector (HONDA TSUSIN MR-50RMA) |

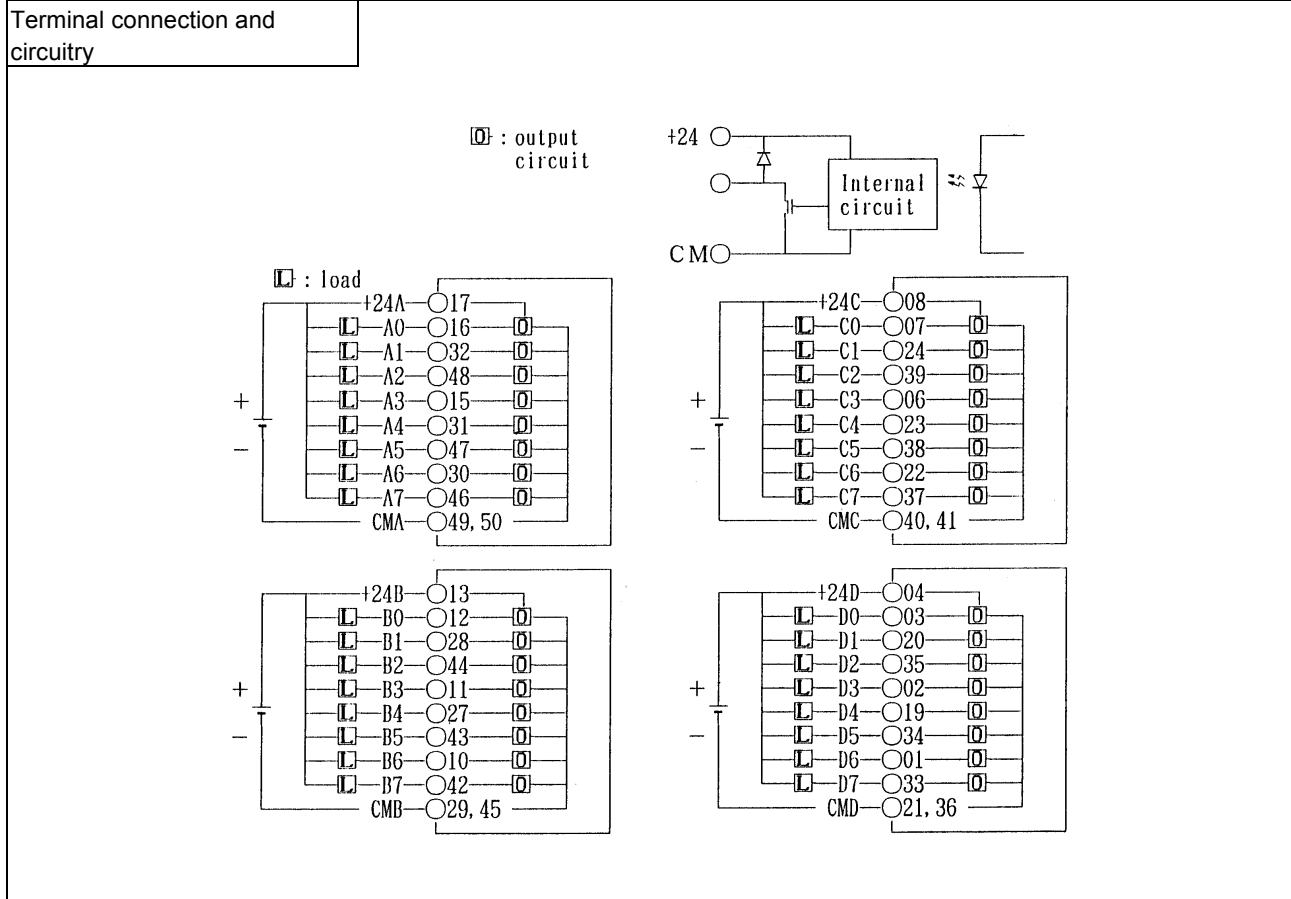

NOTE
 For the common (CMA, CMB, CMC, CMD) , make sure to use both of them.

(19) Output module AOD32C2

| Item | | Specifications |
|-------------------------------|--------|--------------------------------------------------------------------------------|
| Points/module | | 32 points |
| Points/common | | 8 points/common |
| Sink/source current | | Sink current type |
| Rated load voltage | | 12 to 24VDC +20%, -15% |
| Maximum load current | | 0.3A (however 2A/common) |
| Maximum voltage drop when ON | | 0.24V (load current \times 0.8 Ω) |
| Maximum leak current when OFF | | 0.1mA |
| Response time | OFF ON | Max.2ms |
| | ON OFF | Max.2ms |
| Output display | | Not provided |
| External connection | | Connector (HIROSE ELECTRIC HIF3BB-50PA-2.54DS in accordance with MIL standard) |

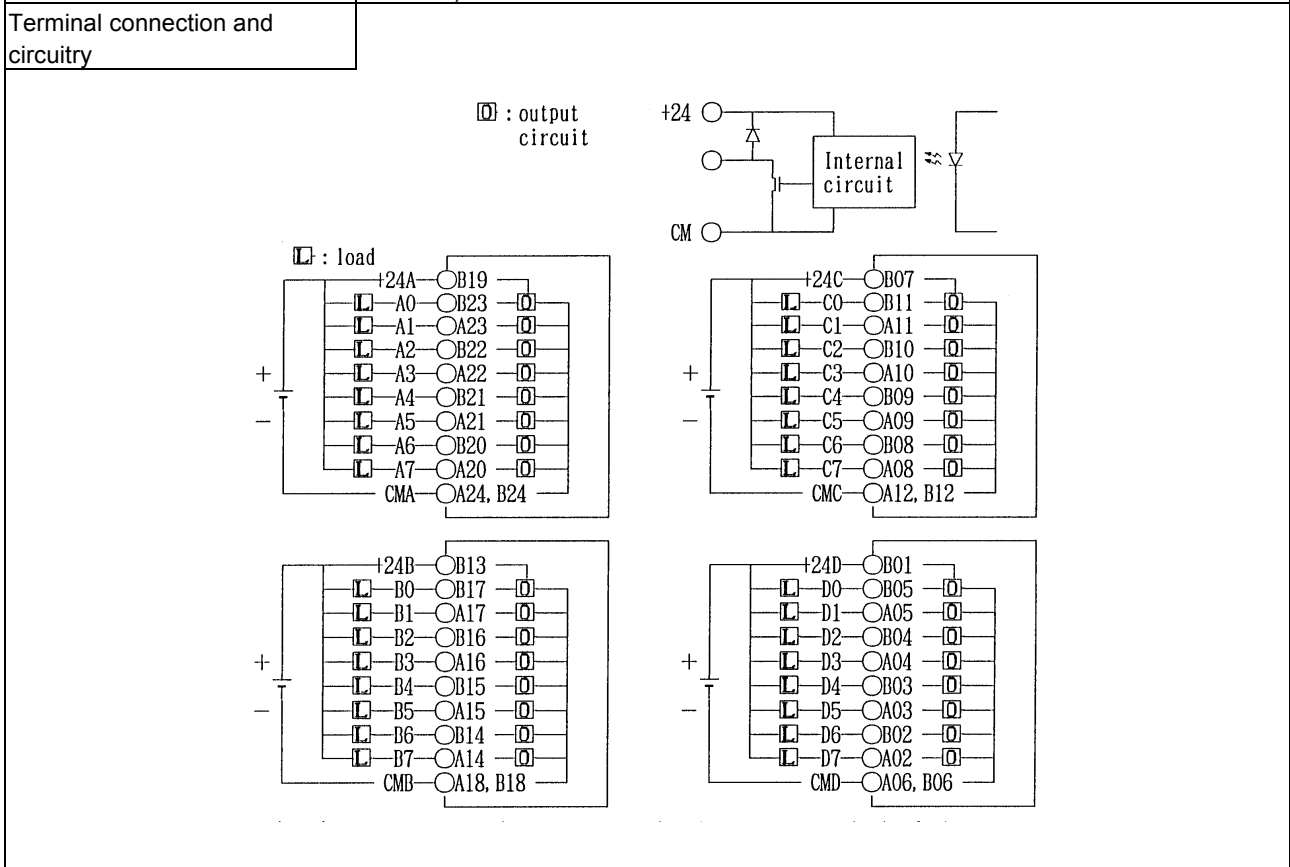

NOTE
For the common (CMA, CMB, CMC, CMD), make sure to use both of them.

(20) Output module AOD32D1

| Item | | Specifications |
|-------------------------------|--------|---------------------------------------------|
| Points/module | | 32 points |
| Points/common | | 8 points/common |
| Sink/source current | | Source current type |
| Rated load voltage | | 12 to 24VDC +20%, -15% |
| Maximum load current | | 0.3A (however 2A/common) |
| Maximum voltage drop when ON | | 0.24V (load current \times 0.8 Ω) |
| Maximum leak current when OFF | | 0.1mA |
| Response Time | OFF ON | Max.2ms |
| | ON OFF | Max.2ms |
| Output display | | Not provided |
| External connection | | Connector (HONDA TSUSIN MR-50RMA) |

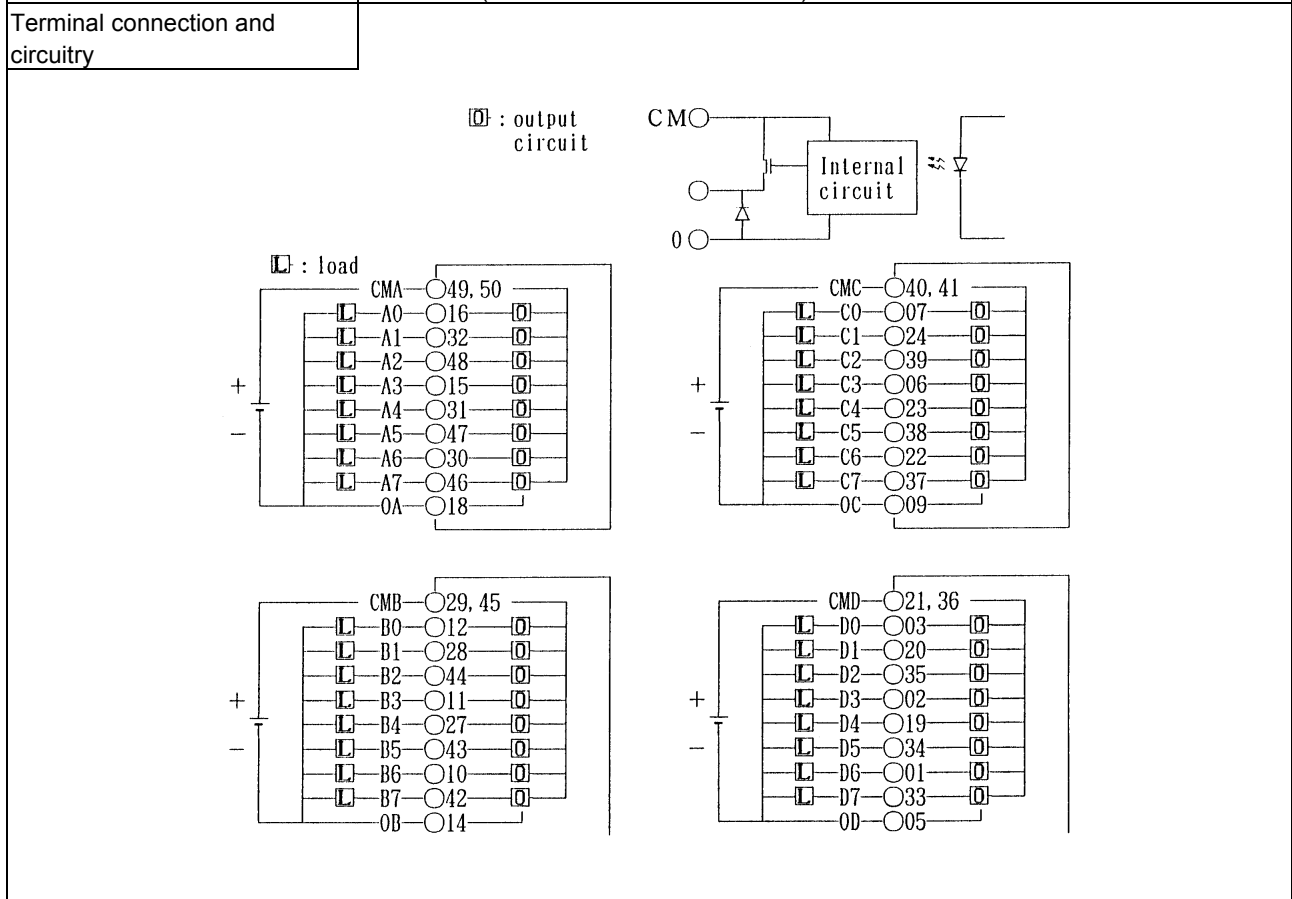

NOTE
For the common (CMA, CMB, CMC, CMD), make sure to use both of them.

(21) Output module AOD32D2

| Item | | Specifications |
|-------------------------------|--------|--------------------------------------------------------------------------------|
| Points/module | | 32 points |
| Points/common | | 8 points/common |
| Sink/source current | | Source current type |
| Rated load voltage | | 12 to 24VDC +20%, -15% |
| Maximum load current | | 0.3A (however 2A/common) |
| Maximum voltage drop when ON | | 0.24V (load current \times 0.8 Ω) |
| Maximum leak current when OFF | | 0.1mA |
| Response time | OFF ON | Max.2ms |
| | ON OFF | Max.2ms |
| Output display | | Not provided |
| External connection | | Connector (HIROSE ELECTRIC HIF3BB-50PA-2.54DS in accordance with MIL standard) |

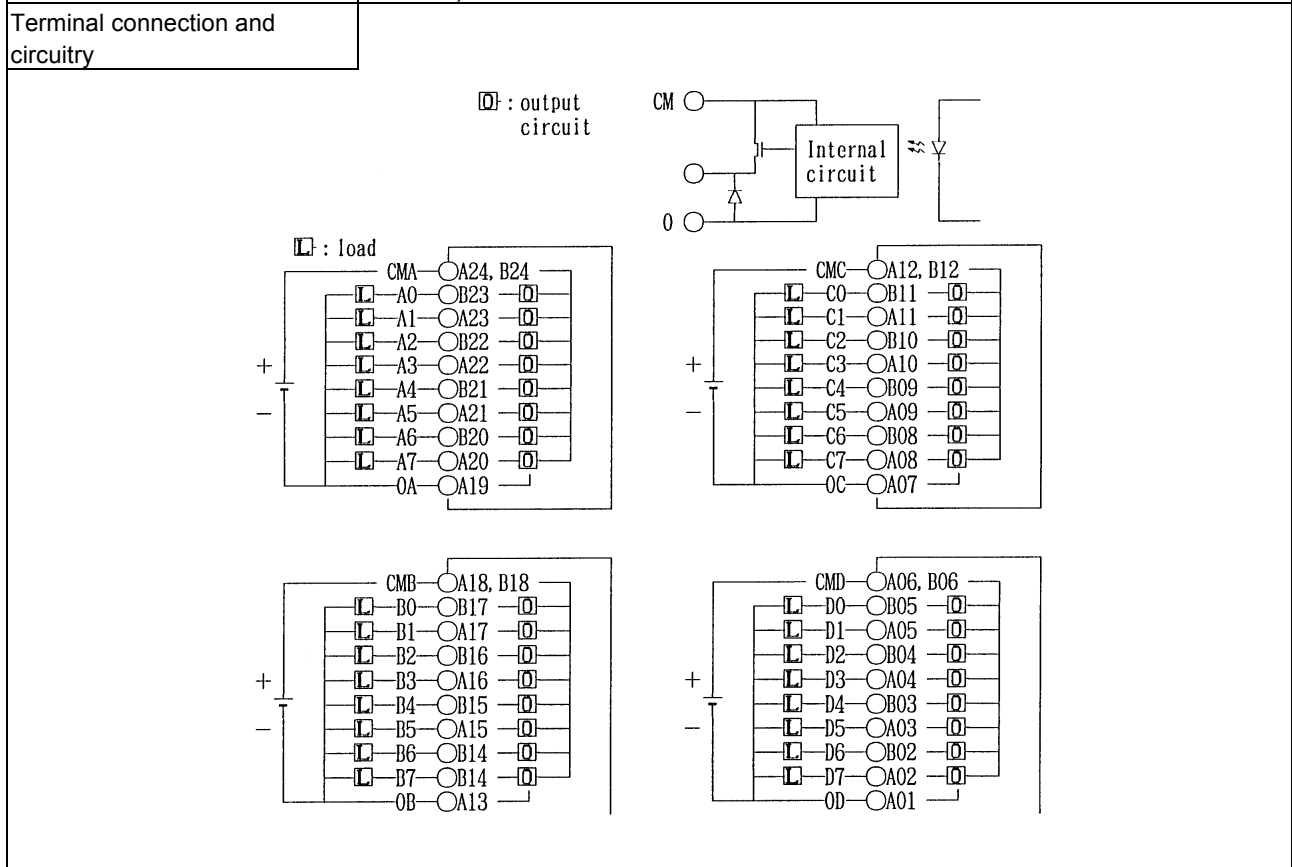

NOTE
For the common (CMA, CMB, CMC, CMD), make sure to use both of them.

(22) Output module AOA05E

| Item | | Specifications | |
|-----------------------------------|--------|--------------------------------------------------------------|--------------------------------------------------------------------------------------------------------------------------------------------------|
| Points/module | | 5 points | |
| Points/common | | 1 points/common | |
| Rated load voltage | | 100 to 230VAC ±15%, 47 to 63Hz | |
| Maximum load current | | 2A/point (however 5A/module) | |
| Maximum rush current | | 25A (1 period) | |
| Limit of load | | Refer to load derating curve (Fig. 5.3 (b)) | |
| Maximum voltage drop when ON | | 1.5Vrms | |
| Maximum leak current when OFF | | 3.0mA (115VAC), 6.0mA (230VAC) | |
| Response time | OFF ON | Max.1ms | This is the value from input to output in the module. The actual value is determined by adding it to the scanning time depending on each system. |
| | ON OFF | Half of the load frequency or less | |
| Output display | | LED display | |
| External connection | | Terminal block connector (20 terminals, M3.5 screw terminal) | |
| Fuse | | 3.2A, 1 piece for each output A0 to A4 | |
| Terminal connection and circuitry | | <p>② : output circuit</p> | |

(23) Output module AOA08E

| Item | | Specifications | |
|-----------------------------------|--------|--------------------------------------------------------------|--------------------------------------------------------------------------------------------------------------------------------------------------|
| Points/module | | 8 points | |
| Points/common | | 4 points/common | |
| Rated load voltage | | 100 to 230VAC ±15%, 47 to 63Hz | |
| Maximum load current | | 1A/point (however 2A/common) | |
| Maximum in rush current | | 10A (1 period) | |
| Maximum voltage drop when ON | | 1.5Vrms | |
| Maximum leak current when OFF | | 3.0mA (115VAC), 6.0mA (230VAC) | |
| Response time | OFF ON | Max.1ms | This is the value from input to output in the module. The actual value is determined by adding it to the scanning time depending on each system. |
| | ON OFF | Half of the load frequency or less | |
| Output display | | LED display | |
| External connection | | Terminal block connector (20 terminals, M3.5 screw terminal) | |
| Fuse | | 3.2A, 1 piece for each output A0 to A3 and A4 to A7 | |
| Terminal connection and circuitry | | <p>⑩ : output circuit</p> | |

(24) Output module AOA12F

| Item | | Specifications | |
|-----------------------------------|--------|---------------------------------------------------------------------------------------------------------------------------------------------------------------------------------------------------------------------------------------------------------------------------------------------------------------------------------------------------------------------------------------------------------------------------------------------------------------|--------------------------------------------------------------------------------------------------------------------------------------------------|
| Points/module | | 12 points | |
| Points/common | | 6 points/common | |
| Rated load voltage | | 100 to 115VAC ±15%, 47 to 63Hz | |
| Maximum load current | | 0.5A/point (however, 2A/common) | |
| Maximum in rush current | | 5A (1 period) | |
| Limit of load | | Refer to load derating curve (Fig. 5.3 (c)) | |
| Maximum voltage drop when ON | | 1.5Vrms | |
| Maximum leak current when OFF | | 1.5mA (115VAC) | |
| Response time | OFF ON | Max.1ms | This is the value from input to output in the module. The actual value is determined by adding it to the scanning time depending on each system. |
| | ON OFF | Half of the load frequency or less | |
| Output display | | LED display | |
| External connection | | Terminal block connector (20 terminals, M3.5 screw terminal) | |
| Fuse | | 3.2A, 1 piece for each output A0 to A5 and B0 to B5 | |
| Terminal connection and circuitry | | <p>The diagram illustrates the terminal connection and internal circuitry for the AOA12F output module. It features two 6-point terminal blocks, labeled A0-A5 and B0-B5. The power supply is connected to terminals 7 and 8, which are protected by a fuse. The ground connection is made at terminals 17 and 18. A detailed inset shows the internal output circuitry for a single point, consisting of a Zener diode (Z), a fuse, a diode, and an LED.</p> | |

(25) Output module AOR08G

| Item | | Specifications | |
|-------------------------------|------------|--------------------------------------------------------------|--------------------------------------------------------------------------------------------------------------------------------------------------|
| Points/module | | 8 points | |
| Points/common | | 1 points/common | |
| Maximum load | | 30VDC/250VAC, 4A (resistance load) | |
| Minimum load | | 5VDC, 10mA | |
| Limit of load | | Refer to load derating curve (Fig. 5.3 (d)) | |
| Maximum voltage drop when ON | | 1.5Vrms | |
| Maximum leak current when OFF | | 1.5mA (115VAC) | |
| Response time | OFF ON | Max.15ms | This is the value from input to output in the module. The actual value is determined by adding it to the scanning time depending on each system. |
| | ON OFF | Max.15ms | |
| Output display | | LED display | |
| External connection | | Terminal block connector (20 terminals, M3.5 screw terminal) | |
| Fuse | | 3.2A, 1 piece for each output A0 to A5 and B0 to B5 | |
| Relay life | Mechanical | Min. 20,000,000 times | |
| | Electrical | Min. 100,000 times (resistance load) | |

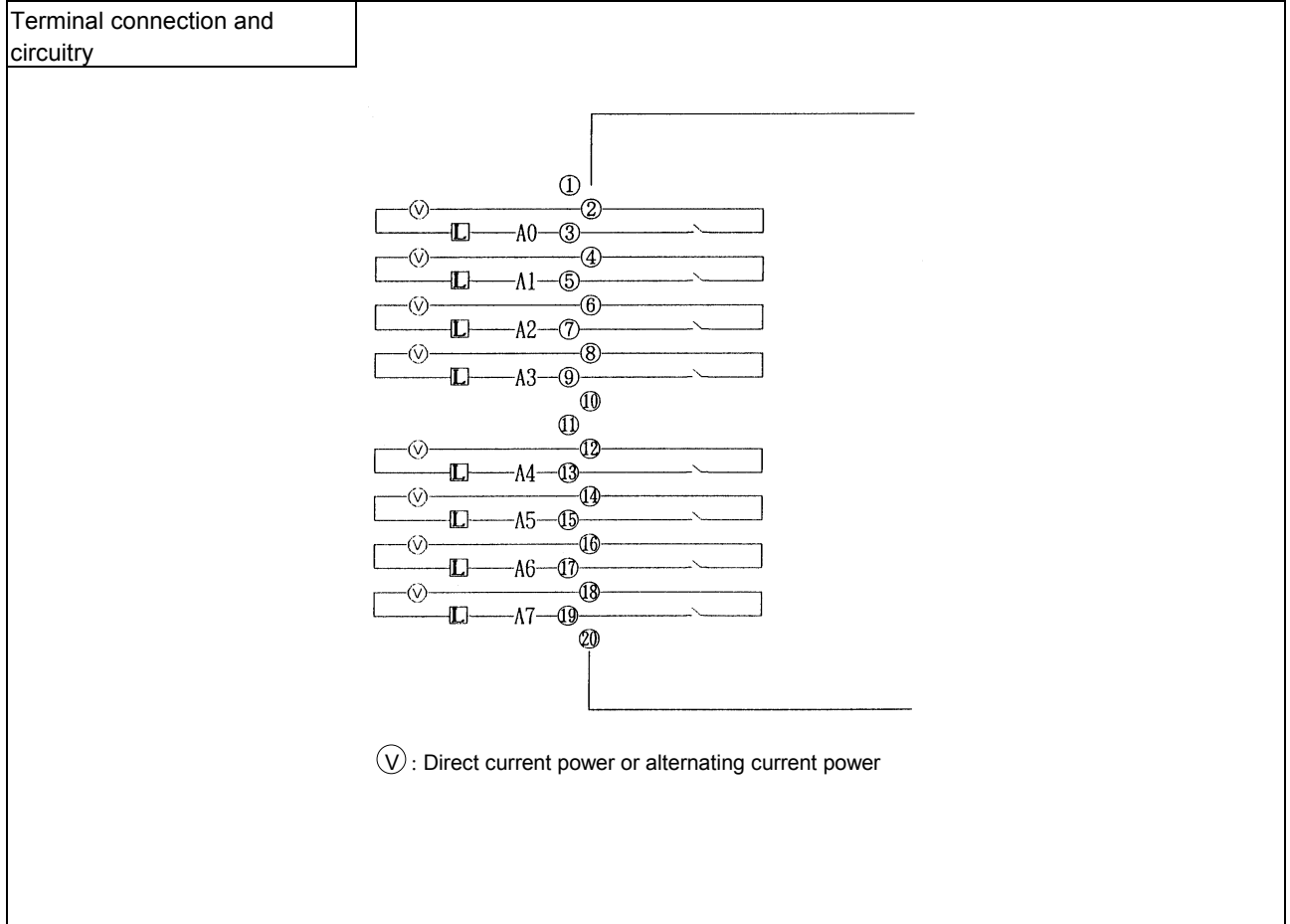

(26) Output module AOR16G

| Item | | Specifications | |
|-----------------------------------|------------|---------------------------------------------------------------|--------------------------------------------------------------------------------------------------------------------------------------------------|
| Points/module | | 16 points | |
| Points/common | | 4 points/common | |
| Maximum load | | 30VDC/250VAC, 2A (resistance load) | |
| Minimum load | | 5VDC, 10mA | |
| Maximum current | | 4A/common | |
| Limit of load | | Refer to load derating curve (Fig. 5.3 (e)) | |
| Response time | OFF ON | Max.15ms | This is the value from input to output in the module. The actual value is determined by adding it to the scanning time depending on each system. |
| | ON OFF | Max.15ms | |
| Output display | | LED display | |
| External connection | | Terminal block connector (20 terminals, M3.5 screw terminal) | |
| Relay life | Mechanical | Min. 20,000,000 times | |
| | Electrical | Min. 100,000 times (resistance load) | |
| Terminal connection and circuitry | | <p>(V): Direct current power or alternating current power</p> | |

(27) Output module AOR16H2

| Item | | Specifications | |
|-----------------------------------|------------|-----------------------------------------------------------------------------------------------------|--------------------------------------------------------------------------------------------------------------------------------------------------|
| Points/module | | 16 points | |
| Points/common | | 4 points/common | |
| Maximum load | | 30VDC, 2A (resistance load) | |
| Minimum load | | 5VDC, 10mA | |
| Maximum current | | 4A/common | |
| Limit of load | | Refer to load derating curve (Fig. 5.3 (e)) | |
| Response time | OFF ON | Max.15ms | This is the value from input to output in the module. The actual value is determined by adding it to the scanning time depending on each system. |
| | ON OFF | Max.15ms | |
| Output display | | LED display | |
| External connection | | Connector (HIROSE ELECTRIC HIF3BB-50PA-2.54DS in accordance with MIL standard) | |
| Relay life | Mechanical | Min. 20,000,000 times | |
| | Electrical | Min. 100,000 times (resistance load) | |
| Terminal connection and circuitry | | <p style="text-align: center;">Load</p> <p style="text-align: center;">⎓ : Direct current power</p> | |

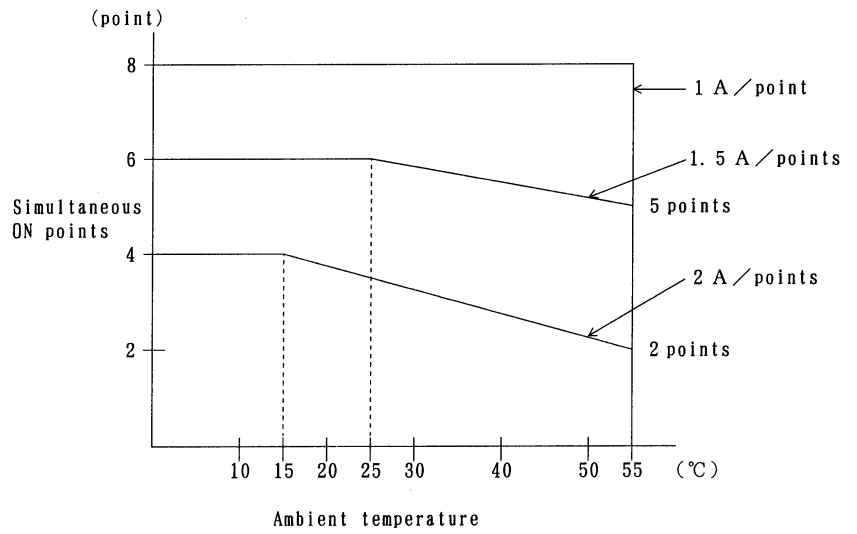

Fig.5.3 (a) AOD08D Load reduction curve

NOTE
 Ambient temperature means the temperature surrounding the I/O unit and not that surrounding the cabinet containing the I/O unit.

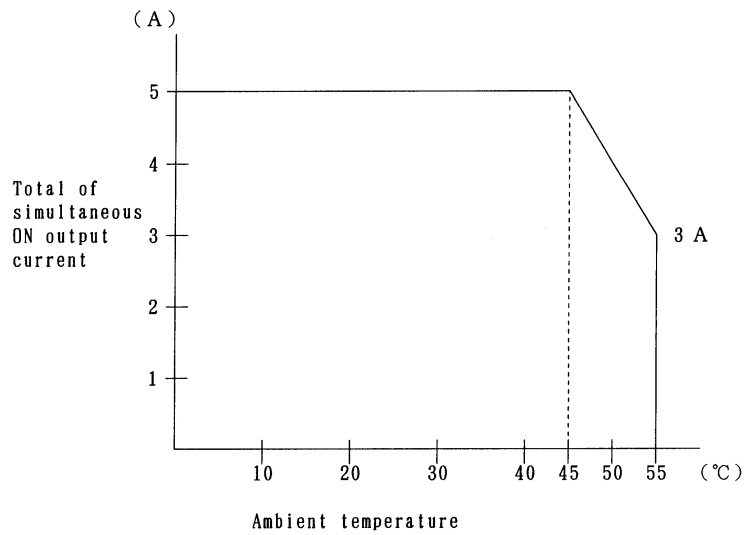

Fig.5.3 (b) AOA05E Load reduction curve

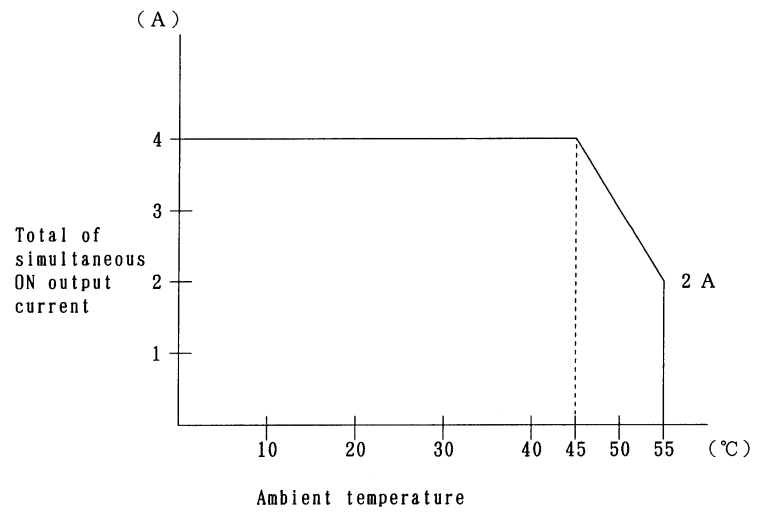

Fig.5.3 (c) AOA12F Load reduction curve

NOTE
Ambient temperature means the temperature surrounding the I/O unit and not that surrounding the cabinet containing the I/O unit.

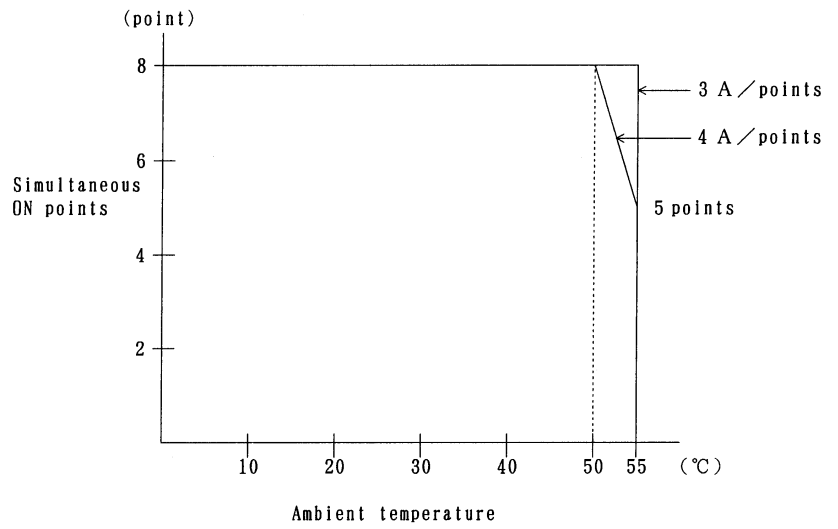

Fig.5.3 (d) AOR08G Load reduction curve

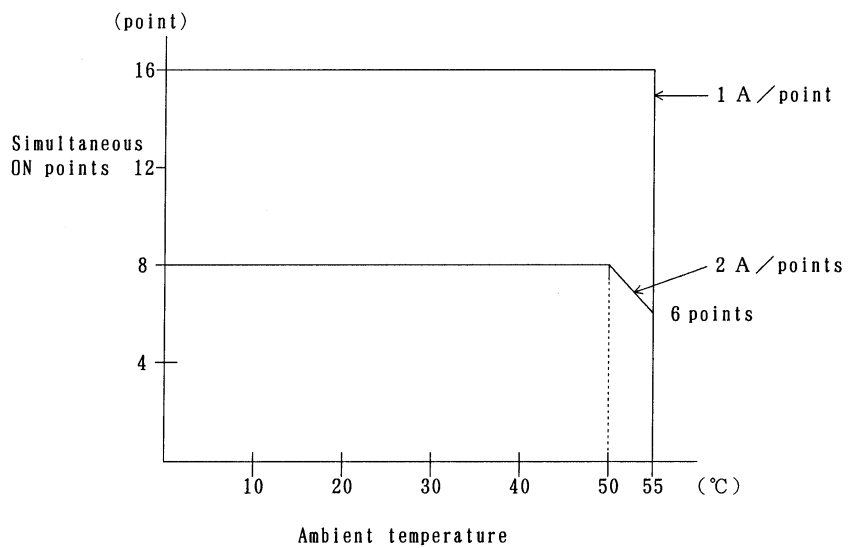

Fig.5.3 (e) AOR16G, AOR16H2 Load reduction curve

NOTE
 Ambient temperature means the temperature surrounding the I/O unit and not that surrounding the cabinet containing the I/O unit.

6

ANALOG INPUT MODULE (AAD04A)

6.1

SPECIFICATIONS FOR ANALOG INPUT MODULE

| Item | Specifications | | | | | | | | | | | | |
|-------------------------------|--------------------------------------------------------------------------------------------------------------------------------------------------------------------------------------------------------------------------------------------------------------------------------------------------------------------------------------------------|--------------|----------------|------|-------|---------------|-------|-----------|---|--------------|-------|------|-------|
| Number of input channel | 4 channel/module | | | | | | | | | | | | |
| Analog input | -10VDC to+10VDC(input resistance 4.7M Ω) -20mADC to+20mADC(input resistance 250 Ω) Selectable | | | | | | | | | | | | |
| Digital output | 12 bit binary (complementary representation of "2".) | | | | | | | | | | | | |
| Input/output correspondence | <table border="1"> <thead> <tr> <th>Analog input</th> <th>Digital output</th> </tr> </thead> <tbody> <tr> <td>+10V</td> <td>+2000</td> </tr> <tr> <td>+5V or + 20mA</td> <td>+1000</td> </tr> <tr> <td>0V or 0mA</td> <td>0</td> </tr> <tr> <td>-5V or -20mA</td> <td>-1000</td> </tr> <tr> <td>-10V</td> <td>-2000</td> </tr> </tbody> </table> | Analog input | Digital output | +10V | +2000 | +5V or + 20mA | +1000 | 0V or 0mA | 0 | -5V or -20mA | -1000 | -10V | -2000 |
| Analog input | Digital output | | | | | | | | | | | | |
| +10V | +2000 | | | | | | | | | | | | |
| +5V or + 20mA | +1000 | | | | | | | | | | | | |
| 0V or 0mA | 0 | | | | | | | | | | | | |
| -5V or -20mA | -1000 | | | | | | | | | | | | |
| -10V | -2000 | | | | | | | | | | | | |
| Resolution | 5mV or 20 μ A | | | | | | | | | | | | |
| Total precision | Voltage input \pm 0.5%(For full scale) Current input \pm 1%(For full scale) | | | | | | | | | | | | |
| Conversionary time | Max.2ms(note) | | | | | | | | | | | | |
| Maximum input voltage/current | \pm 15V, \pm 30mA | | | | | | | | | | | | |
| Isolation | Photocoupler isolated(between the input signal and the base) However, not isolated between input channels | | | | | | | | | | | | |
| Output connecting | Removable terminal block(20 terminals, M3.5 screw terminal) | | | | | | | | | | | | |
| Required input points | 64 points | | | | | | | | | | | | |

NOTE

Conversion time means that only in a module. Actual response speed is ditermined by adding the scanning time depending on each system to this conversion time.

6.2 CORRESPONDENCE BETWEEN INPUT SIGNALS AND ADDRESSES IN A MODULE

In the analog input module AAD04A, the 4-channel analog input signals are cyclically A-D converted in order, and the converted digital data are written in the following addresses. Therefore, in the PMC program, it is possible at any time to know the values for the analog input signals by referring to the following addresses.

(1) PMC-N, Q (PMC for Series 15 AND F-D Mate)

| Address in module | Bits | | | | | | | | |
|----------------------|-------|-------|-------|-------|-------|-------|-------|-------|-----------|
| | 7 | 6 | 5 | 4 | 3 | 2 | 1 | 0 | |
| 0 | X-0 | X-0 | X-0 | X-0 | D11-0 | D10-0 | D09-0 | D08-0 | Channel 0 |
| 1 | D07-0 | D06-0 | D05-0 | D04-0 | D03-0 | D02-0 | D01-0 | D00-0 | |
| 2 | X-1 | X-1 | X-1 | X-1 | D11-1 | D10-1 | D09-1 | D08-1 | Channel 1 |
| 3 | D07-1 | D06-1 | D05-1 | D04-1 | D03-1 | D02-1 | D01-1 | D00-1 | |
| 4 | X-2 | X-2 | X-2 | X-2 | D11-2 | D10-2 | D09-2 | D08-2 | Channel 2 |
| 5 | D07-2 | D06-2 | D05-2 | D04-2 | D03-2 | D02-2 | D01-2 | D00-2 | |
| 6 | X-3 | X-3 | X-3 | X-3 | D11-3 | D10-3 | D09-3 | D08-3 | Channel 3 |
| 7 | D07-3 | D06-3 | D05-3 | D04-3 | D03-3 | D02-3 | D01-3 | D00-3 | |

D00-n and D11-n correspond to the weights of 2^0 and 2^{11} respectively. Here, D11-n corresponds to the sign bit in the complementary representation of "2."

In addition, in X-n is written the same value as that in D11-n.

NOTE

When addressing I/O modules, the beginning address for this module should be assigned to an even one. Moreover, when an A-D converted value is referred to in a PMC program, make sure to read the data in unit of a word (16 bits).

(2) PMC-M, R (PMC for Series 0, Series 16, Series 18)

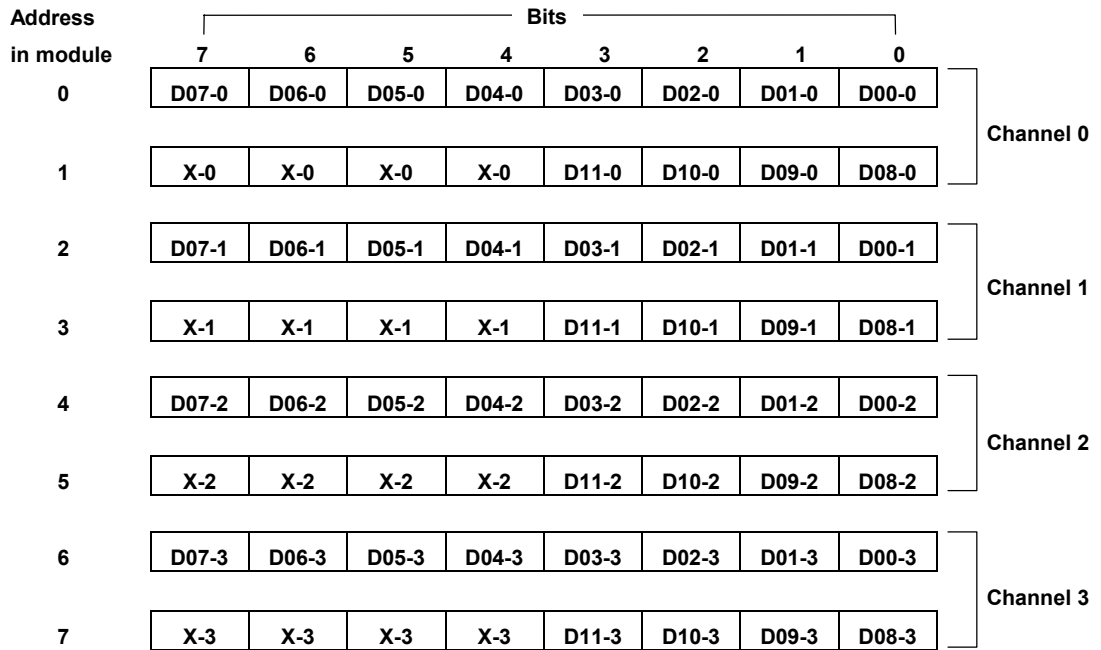

D00-n and D11-n correspond to the weights of 2^0 and 2^{11} respectively. Here, D11-n corresponds to the sign bit in the complementary representation of "2." In addition, in X-n is written the same value as that in D11-n.

NOTE
 When addressing I/O modules, the beginning address for this module should be assigned to an even one. Moreover, when an A-D converted value is referred to in a PMC program, make sure to read the data in unit of a word (16 bits).

6.3 CONNECTING WITH ANALOG INPUT MODULE

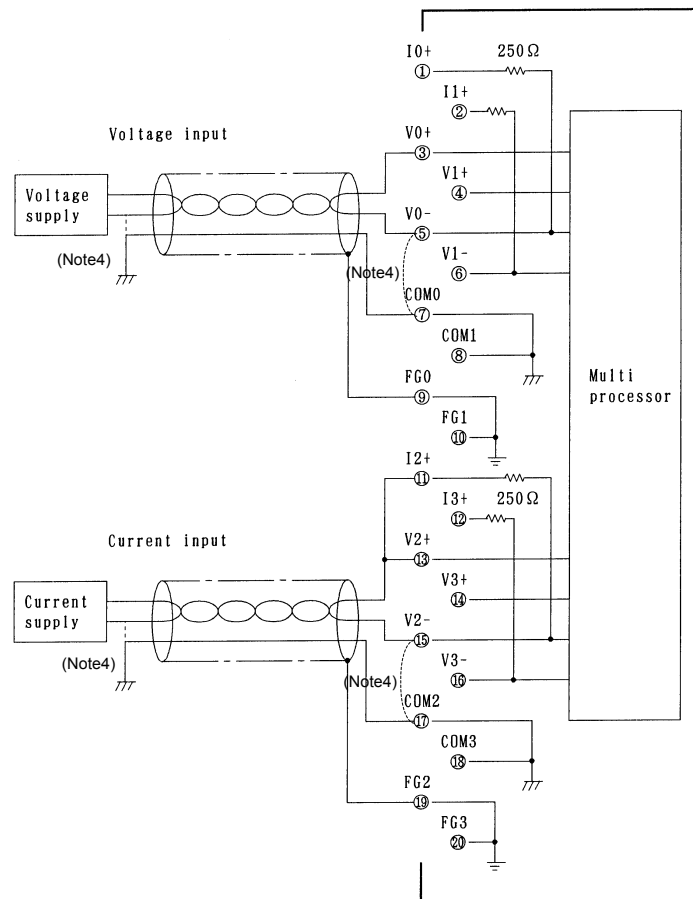

NOTE

- 1 Though the example above shows the connection of channels 0 and 2, it is just the same with the channel 1 (I1+, V1+, V1-, COM1 and FG1) and the channel 3 (I3+, V3+, V3-, COM3 and FG3).
 - 2 Either voltage input or current input can be specified for each channel. When current input is specified, make sure to short-circuit in + and Vn+.
 - 3 Use shielded cables of twisted pair for connecting.
 - 4 Connect the COMX (X: 0 to 3) terminals to the input voltage and current source common (GND) points to fix the ground potential of the conversion section in the module at the ground potential of the input power sources.
- The VX- (X: 0 to 3) and COMX (X: 0 to 3) terminals may have to be strapped depending on the specifications of the input voltage and current sources (if the voltage source external outputs, OUT- and GND, are common).

7

ANALOG OUTPUT MODULE

7.1 12-BIT ANALOG OUTPUT MODULE (ADA02A)

7.1.1 Specification

| Item | Specification | | | | | | | | | | | | |
|----------------------------------|----------------------------------------------------------------------------------------------------------------------------------------------------------------------------------------------------------------------------------------------------------------------------------------------------------------------------------------|---------------|---------------|-------|------|-------|--------------|---|-----------|-------|-----|-------|------|
| Number of output channels | 2 channels/module | | | | | | | | | | | | |
| Digital input | 12-bit binary (2's complement representation) | | | | | | | | | | | | |
| Analog output | -10VDC to +10VDC(external load resistance: 10K Ω or more) (Note 1) 0mADC to +20mADC(external load resistance: 400 Ω or less) | | | | | | | | | | | | |
| Input/output correspondence | <table border="1"> <thead> <tr> <th>Digital input</th> <th>Analog output</th> </tr> </thead> <tbody> <tr> <td>+2000</td> <td>+10V</td> </tr> <tr> <td>+1000</td> <td>+5V or +20mA</td> </tr> <tr> <td>0</td> <td>0V or 0mA</td> </tr> <tr> <td>-1000</td> <td>-5V</td> </tr> <tr> <td>-2000</td> <td>-10V</td> </tr> </tbody> </table> | Digital input | Analog output | +2000 | +10V | +1000 | +5V or +20mA | 0 | 0V or 0mA | -1000 | -5V | -2000 | -10V |
| Digital input | Analog output | | | | | | | | | | | | |
| +2000 | +10V | | | | | | | | | | | | |
| +1000 | +5V or +20mA | | | | | | | | | | | | |
| 0 | 0V or 0mA | | | | | | | | | | | | |
| -1000 | -5V | | | | | | | | | | | | |
| -2000 | -10V | | | | | | | | | | | | |
| Resolution | 5mV or 20 μ A | | | | | | | | | | | | |
| Comprehensive accuracy | Voltage output $\pm 0.5\%$ (For the full scale) Current output $\pm 1\%$ (For the full scale) | | | | | | | | | | | | |
| Converting time | 1ms or less (Note 2) | | | | | | | | | | | | |
| Insulation | Photocoupler insulation (between output signal and base). However, non-insulation between output channels. | | | | | | | | | | | | |
| External connection | At removable terminal block (20 terminals, M3.5 screw terminals) | | | | | | | | | | | | |
| Number of occupied output points | 32 | | | | | | | | | | | | |

NOTE

- 1 It is possible to select whether the analog output module is to be used with voltage or current output.
- 2 The converting time is the one only inside the module. The actual response time is added a scan time that is determined by the system.

7.1.2 Correspondence between Output Signals and Addresses in a Module

In the analog output module ADA02A, a 12-bit digital value is written into each of the following addresses to output the desired voltage/current to its corresponding analog output.

(1) For PMC-N/Q (PMC for Series 15/F-D Mate)

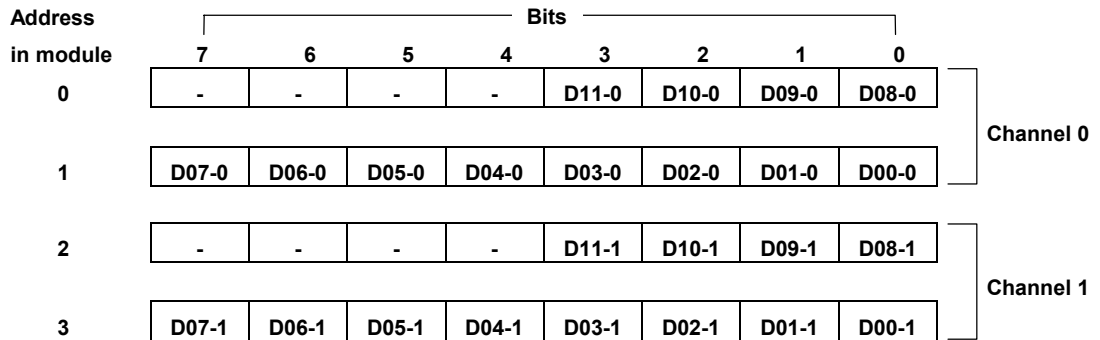

(2) For PMC-M/R (PMC for Series 0/Series 16)

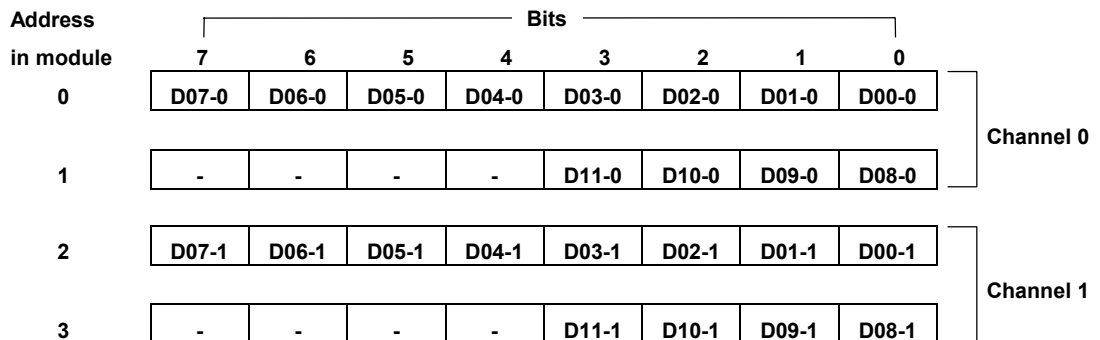

D00-n corresponds to the 2^0 weight, while D11-n corresponds to the 2^{11} weight.

However, D11-n corresponds to the code bit 2's complement representation.

NOTE

When setting an I/O module address, this module initial address must be assigned to an even address. To write a value that is to be converted from digital to analog into a PMC program, be sure to write it in words (16 bits).

7.1.3 Connection to Analog Output Module

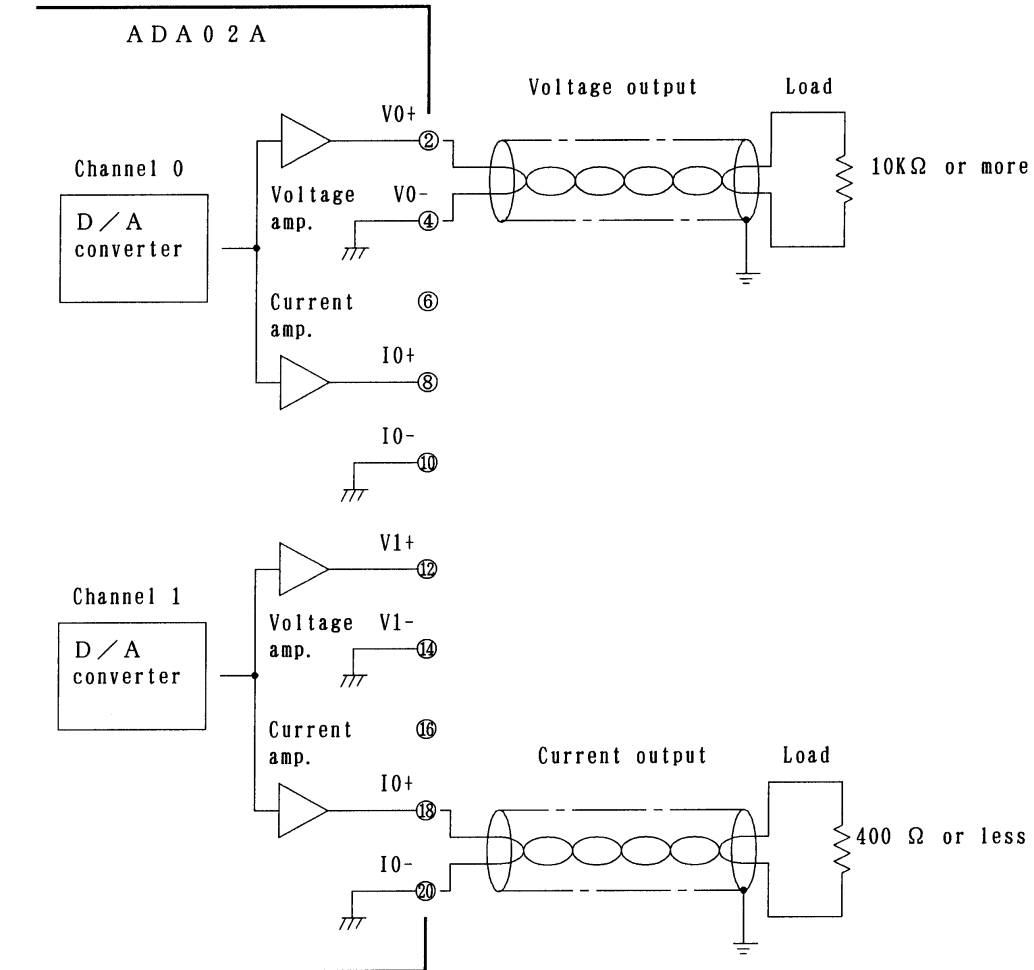

NOTE
1 Use a 2-core twisted shielded cable as the connection cable
2 Ground the cable shield on the load side.

7.2 FOURTEEN-BIT ANALOG OUTPUT MODULE (ADA02B)

7.2.1 Specification

| Item | Specification | | | | | | | | | | | | | | | | | | | | |
|----------------------------------|-------------------------------------------------------------------------------------------------------------------------------------------------------------------------------------------------------------------------------------------------------------------------------------------------------------------------------------------------------------------------------------------------------------------------------------------------------------------------|----------------|---------------|--|----------------|----------------|-------|------|-------|-------|-----|-------|---|---|---|-------|-----|---|-------|------|---|
| Number of output channels | 2 channels/module | | | | | | | | | | | | | | | | | | | | |
| Digital input | 14-bit binary (2's complement representation) | | | | | | | | | | | | | | | | | | | | |
| Analog output | <ul style="list-style-type: none"> •Voltage output -10 VDC to +10 VDC (external load resistance of 10 kΩ or higher) (NOTE 1) •Current output 0 mADC to +20 mADC (external load resistance of 400Ω or lower) | | | | | | | | | | | | | | | | | | | | |
| Input/output correspondence | <table border="1"> <thead> <tr> <th rowspan="2">Digital input</th> <th colspan="2">Analog output</th> </tr> <tr> <th>Voltage output</th> <th>Current output</th> </tr> </thead> <tbody> <tr> <td>+8000</td> <td>+10V</td> <td>+20mA</td> </tr> <tr> <td>+4000</td> <td>+5V</td> <td>+10mA</td> </tr> <tr> <td>0</td> <td>0</td> <td>0</td> </tr> <tr> <td>-4000</td> <td>-5V</td> <td>-</td> </tr> <tr> <td>-8000</td> <td>-10V</td> <td>-</td> </tr> </tbody> </table> | Digital input | Analog output | | Voltage output | Current output | +8000 | +10V | +20mA | +4000 | +5V | +10mA | 0 | 0 | 0 | -4000 | -5V | - | -8000 | -10V | - |
| Digital input | Analog output | | | | | | | | | | | | | | | | | | | | |
| | Voltage output | Current output | | | | | | | | | | | | | | | | | | | |
| +8000 | +10V | +20mA | | | | | | | | | | | | | | | | | | | |
| +4000 | +5V | +10mA | | | | | | | | | | | | | | | | | | | |
| 0 | 0 | 0 | | | | | | | | | | | | | | | | | | | |
| -4000 | -5V | - | | | | | | | | | | | | | | | | | | | |
| -8000 | -10V | - | | | | | | | | | | | | | | | | | | | |
| Resolution | Voltage output: 1.25 mV Current output: 2.5 μ A | | | | | | | | | | | | | | | | | | | | |
| Overall precision | Voltage output: \pm 0.5% (of the full scale) Current output: \pm 1% (of the full scale) | | | | | | | | | | | | | | | | | | | | |
| Converting time | 1 ms or shorter (NOTE 2) | | | | | | | | | | | | | | | | | | | | |
| Insulation | Photocoupler-based insulation between output signal and base, but no insulation between output channels | | | | | | | | | | | | | | | | | | | | |
| External connection | At removable terminal block (with twenty M3.5 screw terminals) | | | | | | | | | | | | | | | | | | | | |
| Number of occupied output points | 32 | | | | | | | | | | | | | | | | | | | | |

NOTE

- 1 It is possible to select whether the analog output module is to be used with voltage output or current output.
- 2 The converting time is that inside the module. The actual response time is added the scan time that is determined by the system.

7.2.2 Correspondence between Output Signals and Addresses in the Module

In the ADA02B analog output module, a 14-bit digital value is written to each of the following address to output the desired voltage/current from its corresponding analog output.

- For PMC-M/R (PMC for Series 0/Series 16)

| Address in module | Bits | | | | | | | | |
|----------------------|-------|-------|-------|-------|-------|-------|-------|-------|-----------|
| | 7 | 6 | 5 | 4 | 3 | 2 | 1 | 0 | |
| 0 | D07-0 | D06-0 | D05-0 | D04-0 | D03-0 | D02-0 | D01-0 | D00-0 | Channel 0 |
| 1 | - | - | D13-0 | D12-0 | D11-0 | D10-0 | D9-0 | D8-0 | |
| 2 | D07-1 | D06-1 | D05-1 | D04-1 | D03-1 | D02-1 | D01-1 | D00-1 | Channel 1 |
| 3 | - | - | D13-1 | D12-1 | D11-1 | D10-1 | D9-1 | D8-1 | |

D00-n (where n is 0 or 1) corresponds to a weight of 2^0 , and D13-n to a weight of 2^{13} . However, D13-n corresponds to the sign bit of a two's complement representation.

7.2.3 Connection between the Analog Output Module and Load

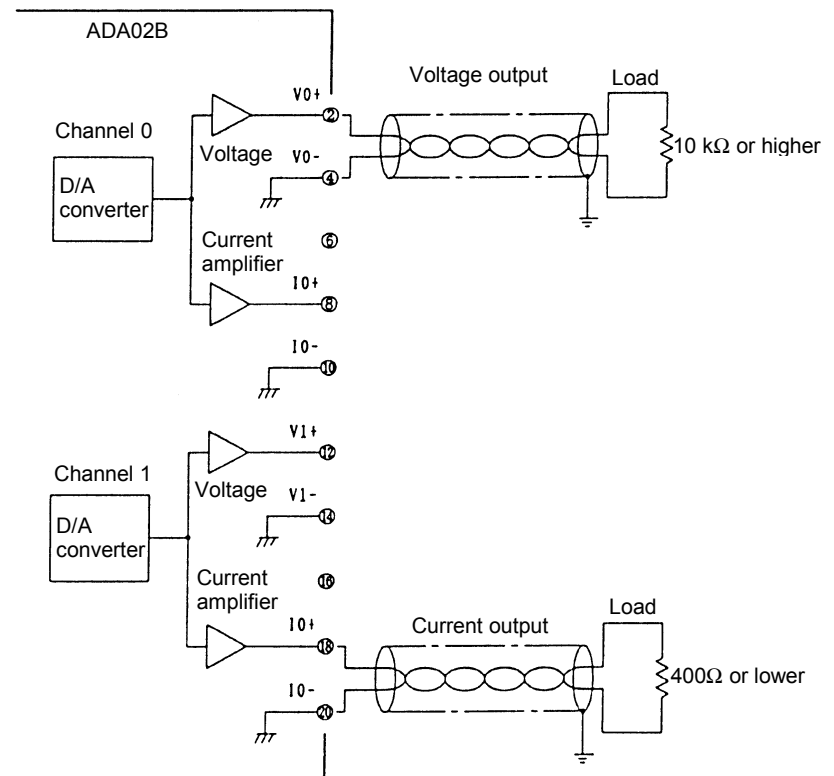

NOTE

- 1 Use a shielded 2-conductor twisted pair cable for the connection between the analog output module and load.
- 2 Ground the cable shielding on the load side.

8

HIGH SPEED COUNTER MODULE

8.1 OUTLINE OF HIGH SPEED COUNTER MODULE

The high speed counter module consists of a counter which counts the pulses sent from a pulse generator such as a position detector in the machine tool and comparison registers for comparing preset values with counter data. The module can read the counter data and output the results of comparison to the machine.

The pulse counter module has two operation modes, A and B. Simplified configuration diagrams in modes A and B are shown below.

A. Mode A

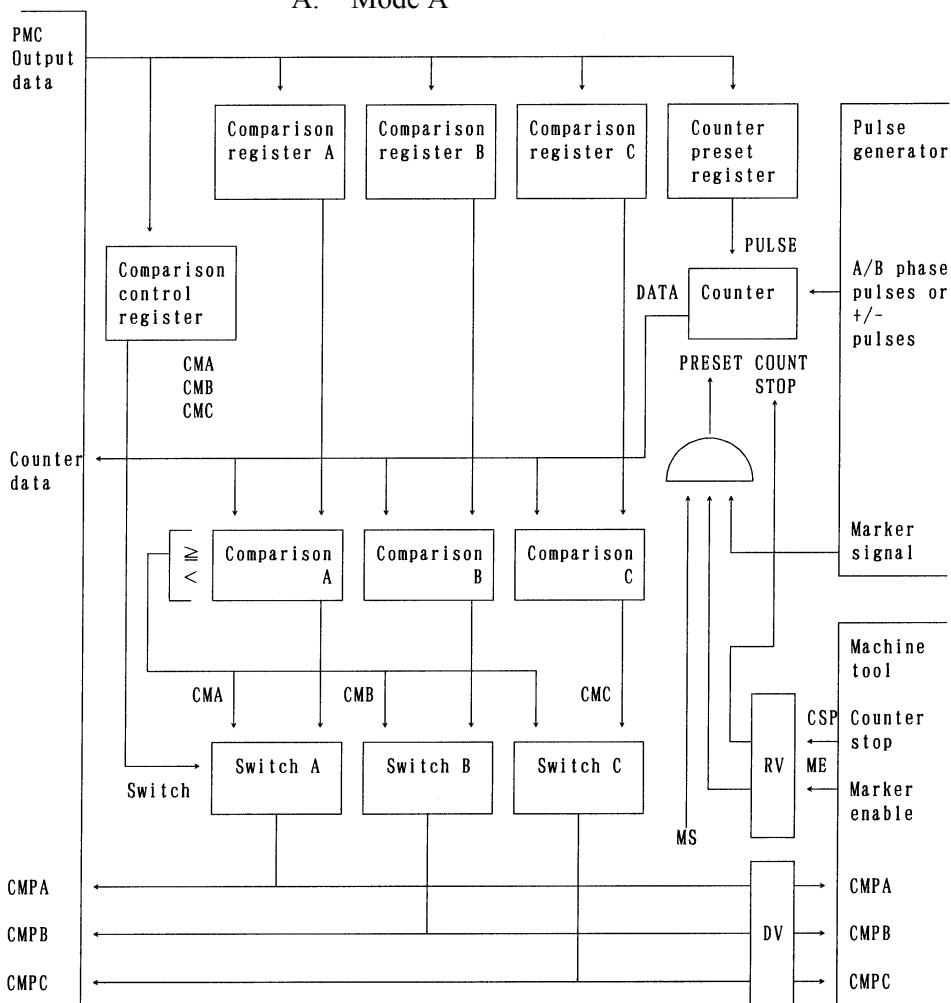

B. Mode B

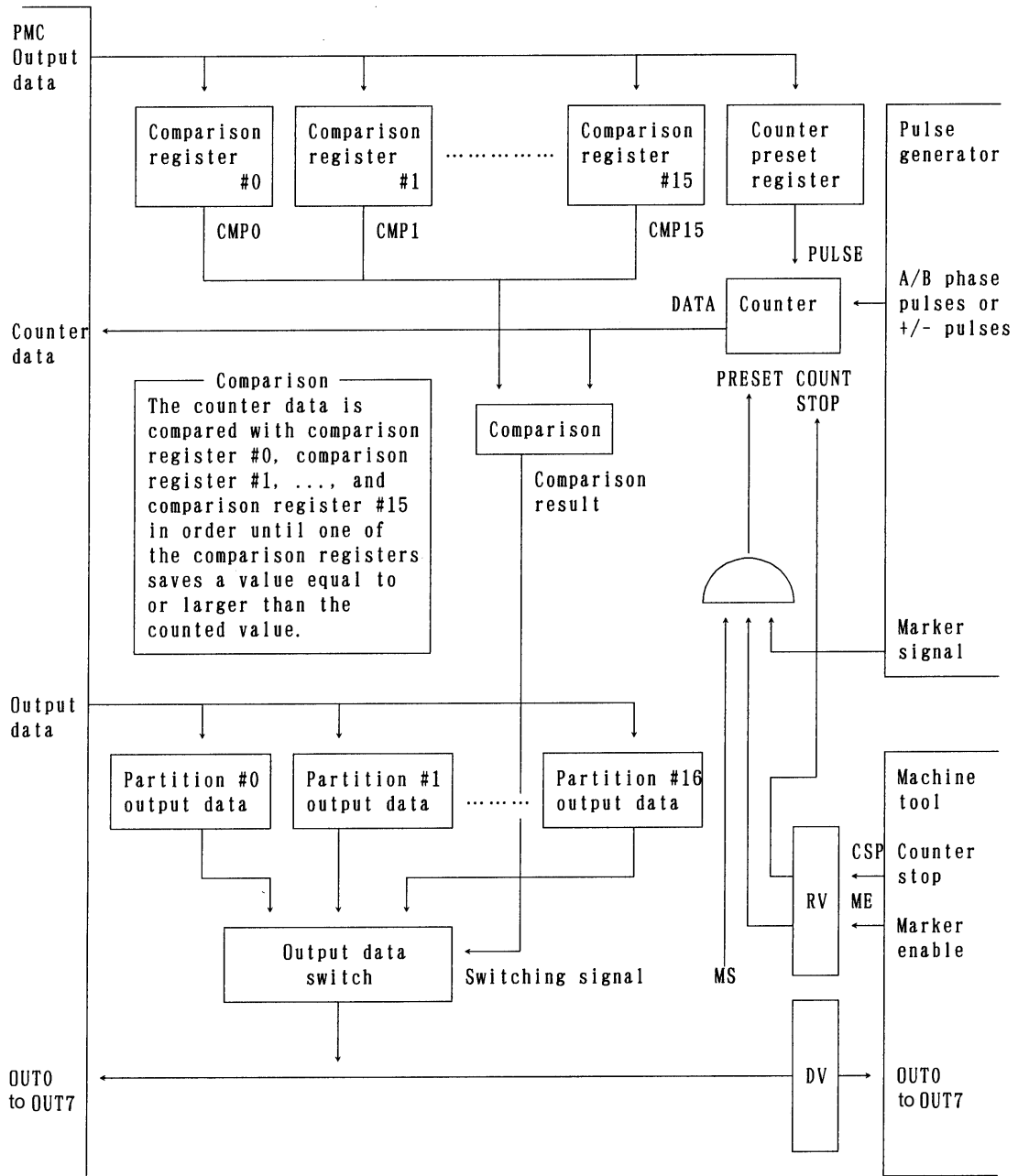

8.2 SPECIFICATIONS OF HIGH SPEED COUNTER MODULE

8.2.1 Pulse counter

- (1) Binary up/down counter (1)
- (2) Counter capacity
0 to 8, 388, 607
- (3) Counter data
The pulse counter can preset data and read count data.

8.2.2 Comparison function

- (1) Mode A
 - A. Comparison register (23 bits)
Comparison registers A, B, and C are provided. The values to be compared are preset in the comparison registers.
 - B. Comparison output
The results (CMPA, CMPB, and CMPC) of comparing the count data in the pulse counter with the data set in the comparison registers are output.
 - C. Comparison output values
The comparison output values are set as listed in the table below. The values depend on the states of CMA, CMB, and CMC, the comparison mode signals from the PMC.

| | Counter value comparison register value | Counter value > comparison register value |
|-------|--------------------------------------------|----------------------------------------------|
| CMA=0 | CMPA=0 | CMPA=1 |
| CMB=0 | CMPB=0 | CMPB=1 |
| CMC=0 | CMPC=0 | CMPC=1 |
| CMA=1 | CMPA=1 | CMPA=0 |
| CMB=1 | CMPB=1 | CMPB=0 |
| CMC=1 | CMPC=1 | CMPC=0 |

- (2) Mode B
 - A. Comparison register (23 bits)
There are 16 comparison registers #0, #1, ..., #15. The values to be compared are preset in the comparison registers. The preset value in a comparison register having a larger register number should be larger than that in a comparison register having a smaller register number, as follows:
Value in register #0 < value in register #1 < ... < value in register #14 < value in register 15

B. Comparison output

The results (OUT0 to OUT7) of comparing the count data in the pulse counter with the data set in the comparison registers are output.

C. Comparison output values

The count data in the pulse counter is compared with the values in the comparison registers in sequential order from register 0 until the count data is equal to or less than the value in a comparison register. This enables a partition to be made which includes the count data. Then the output data for the partition (which is previously preset) is output. Eight output points (OUT0 to OUT7) are provided.

If the count data is equal to the value in a comparison register, the data in the partition having the same number as the register number is output.

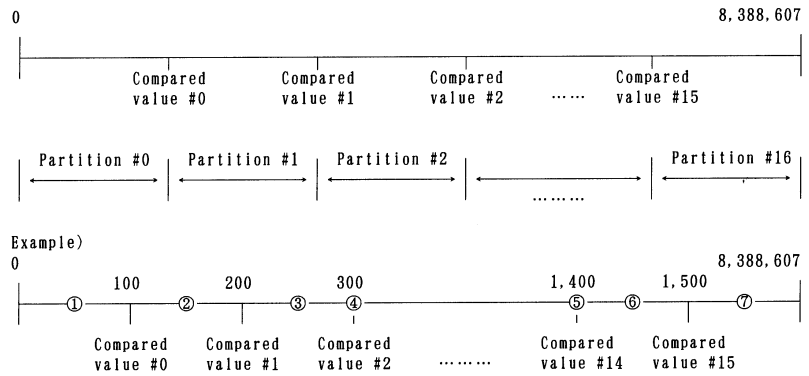

- Output data from partition #0 = 0H
- Output data from partition #1 = 1H
- Output data from partition #2 = 2H
- Output data from partition #3 = 3H
- Output data from partition #4 = 4H
- Output data from partition #5 = 5H
- Output data from partition #6 = 6H
- Output data from partition #7 = 7H
- Output data from partition #8 = 8H
- Output data from partition #9 = 9H
- Output data from partition #10 = 10H
- Output data from partition #11 = 11H
- Output data from partition #12 = 12H
- Output data from partition #13 = 13H
- Output data from partition #14 = 20H
- Output data from partition #15 = 21H
- Output data from partition #16 = FFH

The output data is set as listed in the table below, depending on the counter values in ① to ⑦ above.

| | OUT | | | | | | | |
|---|-----|---|---|---|---|---|---|---|
| | 7 | 6 | 5 | 4 | 3 | 2 | 1 | 0 |
| ① | 0 | 0 | 0 | 0 | 0 | 0 | 0 | 0 |
| ② | 0 | 0 | 0 | 0 | 0 | 0 | 0 | 1 |
| ③ | 0 | 0 | 0 | 0 | 0 | 0 | 1 | 0 |
| ④ | 0 | 0 | 0 | 0 | 0 | 0 | 1 | 0 |
| ⑤ | 0 | 0 | 1 | 0 | 0 | 0 | 0 | 0 |
| ⑥ | 0 | 0 | 1 | 0 | 0 | 0 | 0 | 1 |
| ⑦ | 1 | 1 | 1 | 1 | 1 | 1 | 1 | 1 |

8.2.3 Pulse Interface

The following three types of pulses are entered in the high speed counter module.

- A. Phase A/B pulses: The phase difference between these detection pulses is 90°
- B. +/- pulses: These detection pulses are separated in the positive and negative directions.

Select either type of the detection pulse.

- C. Marker signal: Used to preset data in the pulse counter.

(1) Phase A/B pulse interface

The phase A/B pulses are selected when the PSEL signal is open.

- A. Interface IC
Use differential drivers (SN75113 or equivalent) at the output ports of the pulse generator.
- B. Maximum frequency

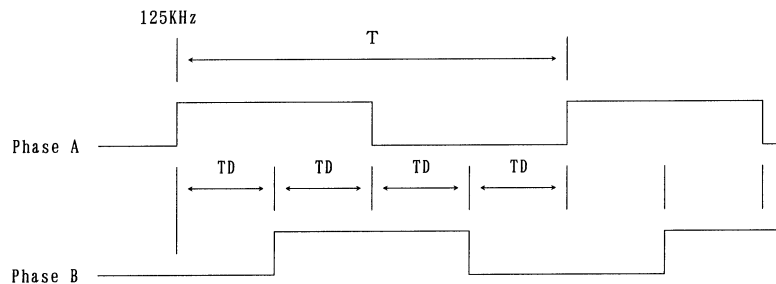

Tmin. = 8μS (minimum period)
TDmin. = 1.2μS (minimum time between edges)

C. Count and direction

A counter multiplied by four compared to phase A and B pulses is provided. It counts positive when phase A advances before phase B and it counts negative when phase B advances before phase A.

Positive count

Advance of phase A before phase B

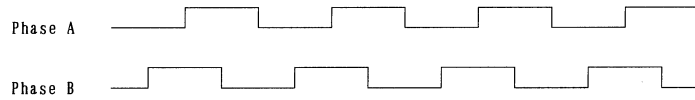

Negative count

Advance of phase B before phase A

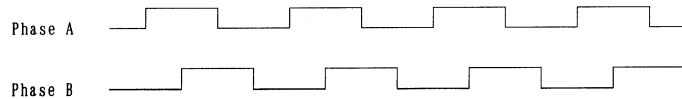

(2) Positive/negative pulse interface

Positive and negative pulses are selected when the PSEL signal is connected to 0 VDC.

A. Interface IC

Use differential drivers (SN75113 or equivalent) at the output ports of the pulse generator.

B. Maximum frequency

500KHz

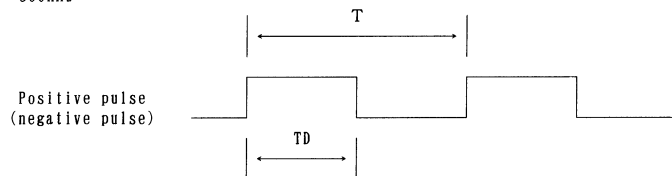

$T_{min.} = 2\mu S$ (minimum period)
 $TD_{min.} = 0.5\mu S$ (minimum pulse width)

(3) Marker signal

A. Interface IC

Use differential drivers (SN75113 or equivalent) at the output ports of the pulse generator.

B. Minimum pulse width

1 μs or more

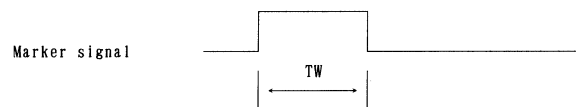

$TW_{min.} = 1\mu S$

8.2.4 External contact input

The pulse counter module uses insulating receivers (having a voltage rating of 24 VDC) at the input ports. The following two types of signal inputs are provided.

- (1) Marker enable signal input (ME)
The contact of the marker enable signal is closed to make the marker signal valid.
This enables data to be preset in the counter.
- (2) Count stop signal input (CSP)
The contact of the count stop signal is closed to stop the count operation.

8.2.5 External contact output

Solid state relays are used for the contacts.

- (1) Mode A
The comparison mode signal outputs A, B, C (CMPA, CMPB, and CMPC) are provided in mode A. These outputs indicate the results of comparing the comparison registers A, B, and C with the pulse counter. The comparison output values are determined depending on whether the control mode signals (CMA, CMB, and CMC) from the PMC are set to 1 or 0.
- (2) Mode B
The results of comparing comparison register #0, comparison register #1, ..., comparison register #15 with the pulse counter are provided in mode B. The comparison output indicates the values in the output data registers for the partitions in which the count data is located. Eight output points are provided. (See Section 8.2.2 (2))

8.2.6 Marker processing

- (1) Mode A
 - A. Synchronization with marker
The counter value is set to the data in the counter preset register at the rising edge of the first marker signal with the MS signal output from the PMC set to 1 and the contact of the marker enable signal input (ME) from the machine closed.
 - B. Marker hold
The MH signal is set to 1 at the rising edge of the first marker signal with the MS signal output from the PMC set to 1 and the contact of the marker enable signal input (ME) from the machine closed. The MH signal is reset when the marker

hold reset (MHR), an output signal from the PMC, is set to 1 or the MS signal output from the PMC is set to 0.

- (2) Mode B
 - A. Synchronization with marker
When the MS signal output from the PMC is 1 and the contact of the marker enable (ME) signal input from the machine is closed, the counter is set to the data in the counter preset register at the rising edge of the first marker signal.
 - B. Maker hold
When the MS signal output from the PMC is 1 and the contact of the marker enable (ME) signal input from the machine is closed, the MH signal is set to 1 at the rising edge of the marker signal. The MH signal is reset when the MS signal output from the PMC is set to 0.

8.2.7 LED indicators

The high speed counter module has the following indicators.

- (1) OK indicator
See below Table.
- (2) ALM0 and ALM1 indicators
See below Table.
- (3) Phase A and B pulses (positive and negative pulses) input signal indicators (A and B)
The phase A pulse input signal indicator is on when the phase A pulse input is active.
The phase B pulse input signal indicator is on when the phase B pulse input is active.
- (4) Marker signal indicator (M)
The marker signal indicator is on while the marker signal (MP) from the pulse generator is active.
- (5) Count stop signal indicator (S)
The count stop signal indicator is on when the contact of the count stop signal input sent from the machine is closed.
- (6) Marker enable signal indicator (E)
The marker enable signal indicator is on when the contact of the marker enable signal input sent from the machine is closed.
- (7) Comparison result output indicators (OUT0, OUT1, OUT2, OUT3, OUT4, OUT5, OUT6, and OUT7)

A. Mode A

The indicators OUT0, OUT1, and OUT2 correspond to the signals CMPA, CMPB, and CMPC. OUT1 goes on when CMPA goes on, OUT2 goes on when CMPB goes on, and OUT3 goes on when CMPC goes on.

B. Mode B

The indicators OUT0 - OUT7 go on corresponding to when the output data OUT0 - OUT7 resulting from the comparisons between the count data and comparison registers are set TO 1.

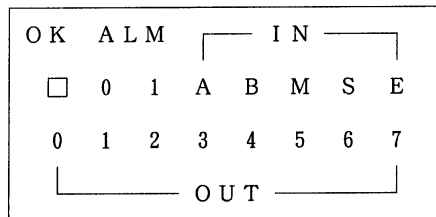

LED indicator panel

| OK | ALM0 | ALM1 | Explanation of alarm |
|----|------|------|---------------------------------|
| ● | ● | ○ | Disconnection alarm |
| ○ | ● | ○ | Self-diagnosis alarm, RAM error |
| ○ | ○ | ● | Self-diagnosis alarm, ROM error |
| ○ | ● | ● | Watch dog alarm |
| ● | ○ | ○ | Normal operation |

● : On
○ : Off

8.3 PMC INTERFACE

8.3.1 Mode A

(1) PMC I/O area

In mode A, four input bytes and four output bytes are used as the I/O area. The bytes in the I/O area have the following names. The input and output directions are specified on the basis of the PMC. The operation mode is set to mode A at power-on.

1) Output data (sent from PMC to high speed counter module)

| | |
|----|---------------------------------|
| 0 | CTRL (control) |
| +1 | DTOH (higher 8-bit data) |
| +2 | DTOM (middle 8-bit data) |
| +3 | DTOL (lower 8-bit data) |

2) Input data (entered from high speed counter module to PMC)

| | |
|----|----------------------------------------|
| 0 | CNTS (counter H and status) |
| +1 | CNTM (middle 8 bits of counter) |
| +2 | CNTL (lower 8 bits of counter) |
| +3 | STTS (status) |

(2) PMC outputs (outputs from PMC)

The PMC outputs are separated into control output CTRL and data outputs DTOH, DTOM, and DTOL. As with normal DOs, the control outputs of bit 3 to bit 7 are controlled independently. The control outputs of bit 0 to bit 2 constitute the SELECT indicating the target data specified by DTOH, DTOM, and DTOL.

1) Control output

CTRL

| | | | | | | | |
|------------|-----------|---|-----------|------------|---------------|---|---|
| 7 | 6 | 5 | 4 | 3 | 2 | 1 | 0 |
| MHR | MS | | CE | PRS | SELECT | | |

PRS : Preset
 CE : Count enable
 MS : Marker synchronization
 MHR : Marker hold reset

- 2) Details of DTOH, DTOM, and DTOL
 The SELECT bits indicate the target data.

| SELECT | |
|--------|---------------------------|
| 0 | CCTR (comparison control) |
| 1 | Counter preset data |
| 2 | Comparison register A |
| 3 | Comparison register B |
| 4 | Comparison register C |
| 7 | Change to mode B |

NOTE
 1 Change to mode B: See Section 8.3.2, "Mode B".
 2 Detail of CCTR

DTOH

| 7 | 6 | 5 | 4 | 3 | 2 | 1 | 0 |
|---|---|---|---|---|-----|-----|-----|
| | | | | | CMC | CMB | CMA |

The DTOM and DTOL are ignored.

- (3) PMC inputs (inputs to PMC)
 The inputs to the PMC include the status and counter data. The data is shown below.

| | |
|----|---------------------------------|
| 0 | CNTS (counter H and status) |
| +1 | CNTM (middle 8 bits of counter) |
| +2 | CNTL (lower 8 bits of counter) |
| +3 | STTS (status) |

NOTE
 1 Details of CNTS

| 7 | 6 | 5 | 4 | 3 | 2 | 1 | 0 |
|-----|-------------------------------------|---|---|---|---|---|---|
| TRA | Counter H (most significant 7 bits) | | | | | | |

TRA : Transfer A

NOTE
 2 Details of STTS

| 7 | 6 | 5 | 4 | 3 | 2 | 1 | 0 |
|-----|-----|-----|----|----|------|------|------|
| TRB | ALM | CSP | ME | MH | CMPC | CMPB | CPMA |

CPMA : Comparison output A
 CMPB : Comparison output B
 CMPC : Comparison output C
 MH : Marker hold
 ME : Marker enable

CSP : Count stop
 ALM : Alarm (disconnection or watch dog alarm)
 TRB : Transfer B

8.3.2 Mode B

Change to mode B

The operation mode is set to mode A at power-on. The following data is output to the counter module and the mode changes from A to B. The mode cannot change from B to A.

| | | | |
|----|-------------|---|----------------------------------|
| 0 | CTRL | : | 0FH (SELECT = 7, PRS = 1) |
| +1 | DTOH | : | 01H |
| +2 | DTOM | : | 00H |
| +3 | DTOL | : | 00H |

(1) PMC I/O area

In mode B, eight input bytes and four output bytes are used as the I/O area. The bytes in the I/O area have the following names. The input and output directions are specified on the basis of the PMC.

1) Output data (sent from PMC to high speed counter module)

| | |
|----|---------------------------------|
| 0 | CTRL (control) |
| +1 | DTOH (higher 8-bit data) |
| +2 | DTOM (middle 8-bit data) |
| +3 | DTOL (lower 8-bit data) |

2) Input data (entered from high speed counter module to PMC)

| | |
|----|----------------------------------------|
| 0 | CNTS (counter H and status) |
| +1 | CNTM (middle 8 bits of counter) |
| +2 | CNTL (lower 8 bits of counter) |
| +3 | STTS (status) |
| +4 | OUTD |
| +5 | MODD |
| +6 | Unused |
| +7 | Unused |

(2) PMC outputs (outputs from PMC)

The PMC outputs are separated into control output CTRL and data outputs DTOH, DTOM, and DTOL. As with normal DOs, the control outputs of bit 5 to bit 7 are controlled independently. The control outputs of bit 0 to bit 4 constitute SELECT indicating the target data specified by DTOH, DTOM, and DTOL.

1) Control outputs

CTRL

| | | | | | | | |
|-----------|-----------|------------|---------------|---|---|---|---|
| 7 | 6 | 5 | 4 | 3 | 2 | 1 | 0 |
| MS | CE | PRS | SELECT | | | | |

- PRS : Preset
- CE : Count enable
- MS : Marker synchronization

2) Details of DTOH, DTOM, and DTOL
The SELECT bits indicate the target data.

| SELECT | Target data |
|--------|-----------------------------------------------------------------------|
| 0 ~ 15 | Comparison data 0 to comparison data 15 |
| 16 | Output data for partition #0 to partition #2 DTOH:#0, M:#1, L:#2 |
| 17 | Output data for partition #3 to partition #5 DTOH:#3, M:#4, L:#5 |
| 18 | Output data for partition #6 to partition #8 DTOH:#6, M:#7, L:#8 |
| 19 | Output data for partition #9 to partition #11 DTOH:#9, M:#10, L:#11 |
| 20 | Output data for partition #12 to partition #14 DTOH:#12, M:#13, L:#14 |
| 21 | Output data for partition #15 and partition #16 DTOH:#15, M:#16 |
| 22 | Counter preset data |

(The numbers of DTOH, DTOM, and DTOL indicate the output data for the partitions specified by the numbers.)

3) PMC inputs (inputs to PMC)
The inputs to the PMC include the status and counter data.
The data is shown below.

| | |
|----|----------------------------------------|
| 0 | CNTS (counter H and status) |
| +1 | CNTM (middle 8 bits of counter) |
| +2 | CNTL (lower 8 bits of counter) |
| +3 | STTS (status) |
| +4 | OUTD |
| +5 | MODD |
| +6 | Not used |
| +7 | Not used |

NOTE
1 Detail of CNTS

| | | | | | | | |
|------------|--------------------------------------------|---|---|---|---|---|---|
| 7 | 6 | 5 | 4 | 3 | 2 | 1 | 0 |
| TRA | Counter H (most significant 7 bits) | | | | | | |

TRA : Transfer A

NOTE
2 Details of STTS

| | | | | | | | | |
|--|-----|-----|-----|----|----|------|------|------|
| | 7 | 6 | 5 | 4 | 3 | 2 | 1 | 0 |
| | TRB | ALM | CSP | ME | MH | OUT2 | OUT1 | OUT0 |

- OUT0 : Bit 0 of comparison output
- OUT1 : Bit 1 of comparison output
- OUT2 : Bit 2 of comparison output
- MH : Marker hold
- ME : Marker enable
- CSP : Count stop
- ALM : Alarm (disconnection or watch dog alarm)
- TRB : Transfer B

NOTE
3 Detail of OUTD

| | | | | | | | | |
|--|------|------|------|------|------|------|------|------|
| | 7 | 6 | 5 | 4 | 3 | 2 | 1 | 0 |
| | OUT7 | OUT6 | OUT5 | OUT4 | OUT3 | OUT2 | OUT1 | OUT0 |

- OUT0 : Bit 0 of comparison output
- OUT1 : Bit 1 of comparison output
- OUT2 : Bit 2 of comparison output
- OUT3 : Bit 3 of comparison output
- OUT4 : Bit 4 of comparison output
- OUT5 : Bit 5 of comparison output
- OUT6 : Bit 6 of comparison output
- OUT7 : Bit 7 of comparison output

NOTE
4 Detail of MODD

| | | | | | | | | |
|--|---|---|---|---|---|---|---|------|
| | 7 | 6 | 5 | 4 | 3 | 2 | 1 | 0 |
| | | | | | | | | MOD0 |

MOD0 : Set to 1 after the mode changes to B.

8.3.3 Details of PMC interface signals

(1) PMC inputs (inputs from PMC)

1) TRA and TRB

The counter data is valid when TRA is equal to TRB and invalid when TRA is not equal to TRB.

- 2) CMPA, CMPB, and CMPC (comparison output signals A, B, and C, only in mode A)
The CMPA, CMPB, and CMPC signals are output signals resulting from the comparison between the comparison registers A, B, and C and the counter data, respectively. The output levels of CMPA, CMPB, and CMPC are determined by the comparison mode signals CMA, CMB, and CMC. When CMA, CMB, and CMC are 0, and the counter data is larger than the values in comparison registers A, B, and C, CMPA, CMPB, and CMPC are set to 1. When CMA, CMB, and CMC are 1, and the counter data is equal to or less than the values in comparison registers A, B, and C, CMPA, CMPB, and CMPC are set to 1.
 - 3) OUT0 to OUT 7 (comparison output signal 0 to comparison output signal 7, only in mode B)
OUT0 - OUT7 correspond to bit 0 to bit 7 in the comparison result output of a single byte.
 - 4) MH (marker hold signal)
The marker hold signal MH is set to 1 at the rising edge of the marker signal when the marker enable signal is 1. The marker hold signal is reset when MHR=1 or MS=0. (In mode B, the marker hold signal MH is reset only when MS=0.)
 - 5) ME (marker enable signal)
The marker enable signal ME enables the marker signal as follows:
ME=1: Marker signal enabled
ME=0: Marker signal disabled
 - 6) CSP (count stop signal)
The counter stops counting when the contact for the external input signal CSP is closed.
 - 7) ALM (alarm signal)
The alarm signal ALM is set to 1 if the signal line for the count pulse or the marker signal is disconnected or short-circuited.
ALM is also set to 1 when the watch dog alarm is activated.
- (2) PMC outputs (outputs from PMC)
- 1) SELECT (selection signal)
The SELECT signal selects the register in which data will be set. That is, the signal specifies the register for presetting data. The SELECT signal should be set when or before the PRS signal is reversed.

- 2) PRS (preset signal)

The PRS signal presets data in registers. If data is set in DTOH, DTOM, and DTOL and then PRS is reversed, the data is set in the register specified by SELECT. Reversing the PRS signal means that PRS changes from level 0 to level 1 or vice versa.

DTOH, DTOM, DTOL, and SELECT should not be changed within two scans after the PRS is reversed. Also, the PRS must not be reversed again within this period.

When SELECT=1, data is set in both the counter preset register and the counter.

Data is set by setting the first PRS to 1 after power-on or after the mode change to B.
- 3) CE (count enable signal)

The CE signal determines whether the counter counts. When the CE is set to 1 and the external input signal CSP closes the contact, the counter retains its value, instead of counting.

When CE = 1 and the CSP external input contact is open, the counter counts input pulses. Presetting the counter requires maintaining CE = 0.
- 4) MS (marker synchronization signal)

The MS signal determines whether marker synchronization is provided. When the MS is 1 and the contact of external input signal ME is closed, the counter is preset to the value in the counter preset register at the rising edge of the first marker signal. If the MS is set to 0 then set to 1 or the MHR is set to 1 then set to 0, marker synchronization is provided again.

(The MHR signal is not included in mode B.)
- 5) MHR (marker hold reset signal, only in mode A)

The MHR signal resets the marker hold (MH) signal which is output to the PMC. The MHR is set to 1 to reset the marker hold signal.
- 6) CMA, CMB, and CMC (comparison mode signals A, B, and C, only in mode A)

The CMA, CMB, and CMC signals specify the levels of the comparison outputs A, B, and C (CMPA, CMPB, and CMPC), respectively.

When CMA, CMB, and CMC are 0, and the value of the counter is larger than the values in comparison registers A, B, and C, CMPA, CMPB, and CMPC are set to 0.

When CMA, CMB, and CMC are 1, and the value of the counter is equal to or less than the values in comparison registers A, B, and C, CMPA, CMPB, and CMPC are set to 1.

8.4 TOTAL CONNECTION OF HIGH SPEED COUNTER MODULE

8.4.1 Connection diagram

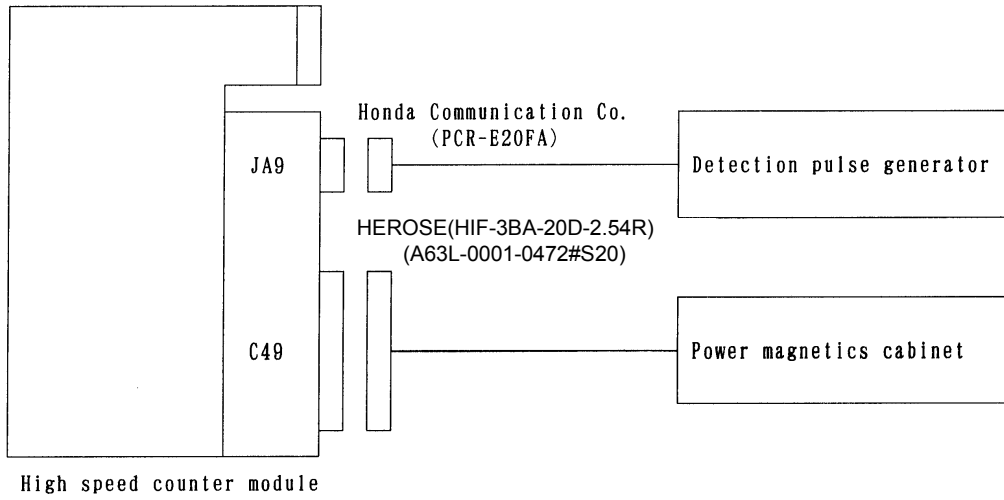

8.4.2 Connector signal list

JA9

| | | | | | | | |
|---|------|----|------|----|--|----|------|
| 9 | +5V | 10 | | 19 | | 20 | +5V |
| 7 | LGND | 8 | PSEL | 17 | | 18 | +5V |
| 5 | MKS | 6 | *MKS | 18 | | 16 | LGND |
| 3 | PBS | 4 | *PBS | 13 | | 14 | LGND |
| 1 | PAS | 2 | *PAS | 11 | | 12 | LGND |

- PAS : Phase A pulse input signal (Negative pulse input signal)(positive)
- *PAS : Phase A pulse input signal (Negative pulse input signal)(negative)
- PBS : Phase B pulse input signal (Positive pulse input signal)(positive)
- *PBS : Phase B pulse input signal (Positive pulse input signal)(negative)
- MKS : Marker signal (positive)
- *MKS : Marker signal (negative)
- PSEL : Pulse select signal
- +5V : 5V (output from this module)
- LGND : 0V

C49

| | A | B |
|----|------|------|
| 01 | ME | |
| 02 | CSP | |
| 03 | COM1 | |
| 04 | | |
| 05 | | |
| 06 | OUT0 | OUT4 |
| 07 | OUT1 | OUT5 |
| 08 | OUT2 | OUT6 |
| 09 | OUT3 | OUT7 |
| 10 | COM2 | COM3 |

- ME : Marker enable signal input
- CSP : Counter stop signal input
- OUT0 : Comparison result output
- OUT1 : Comparison result output
- OUT2 : Comparison result output
- OUT3 : Comparison result output
- OUT4 : Comparison result output
- OUT5 : Comparison result output
- OUT6 : Comparison result output
- OUT7 : Comparison result output
- COM1 : Common signal for ME and CSP
- COM2 : Common signal for comparison result output 0 to comparison result output 3
- COM3 : Common signal for comparison result output 4 to comparison result output 7

8.5 CONNECTION WITH PULSE GENERATOR

8.5.1 Use of phase A and B pulses

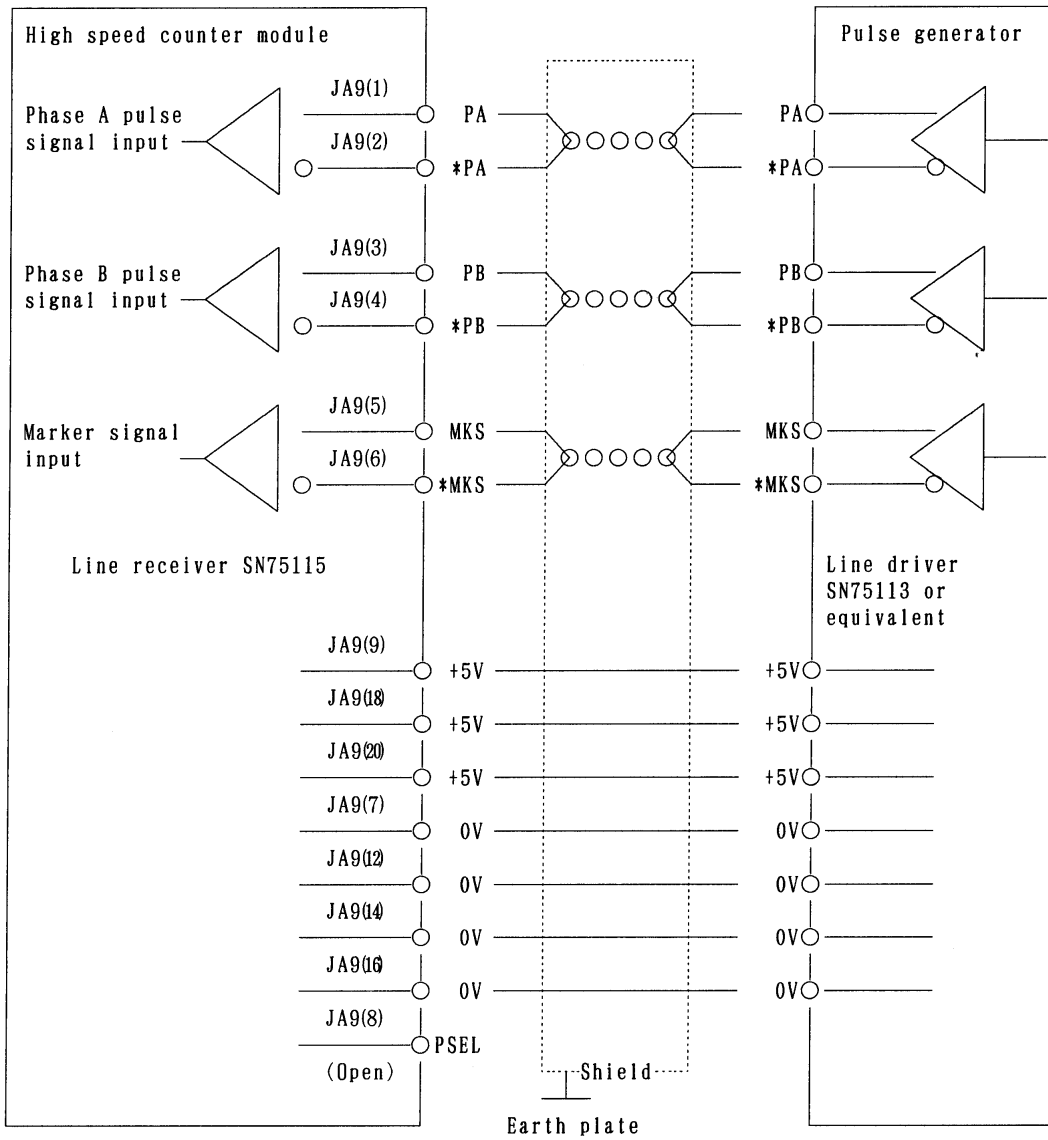

Recommended cable
 A66L-0001-0286 (#20AWG×7, #24AWG×3 Pairs)

8.5.2 Use of positive/negative pulses

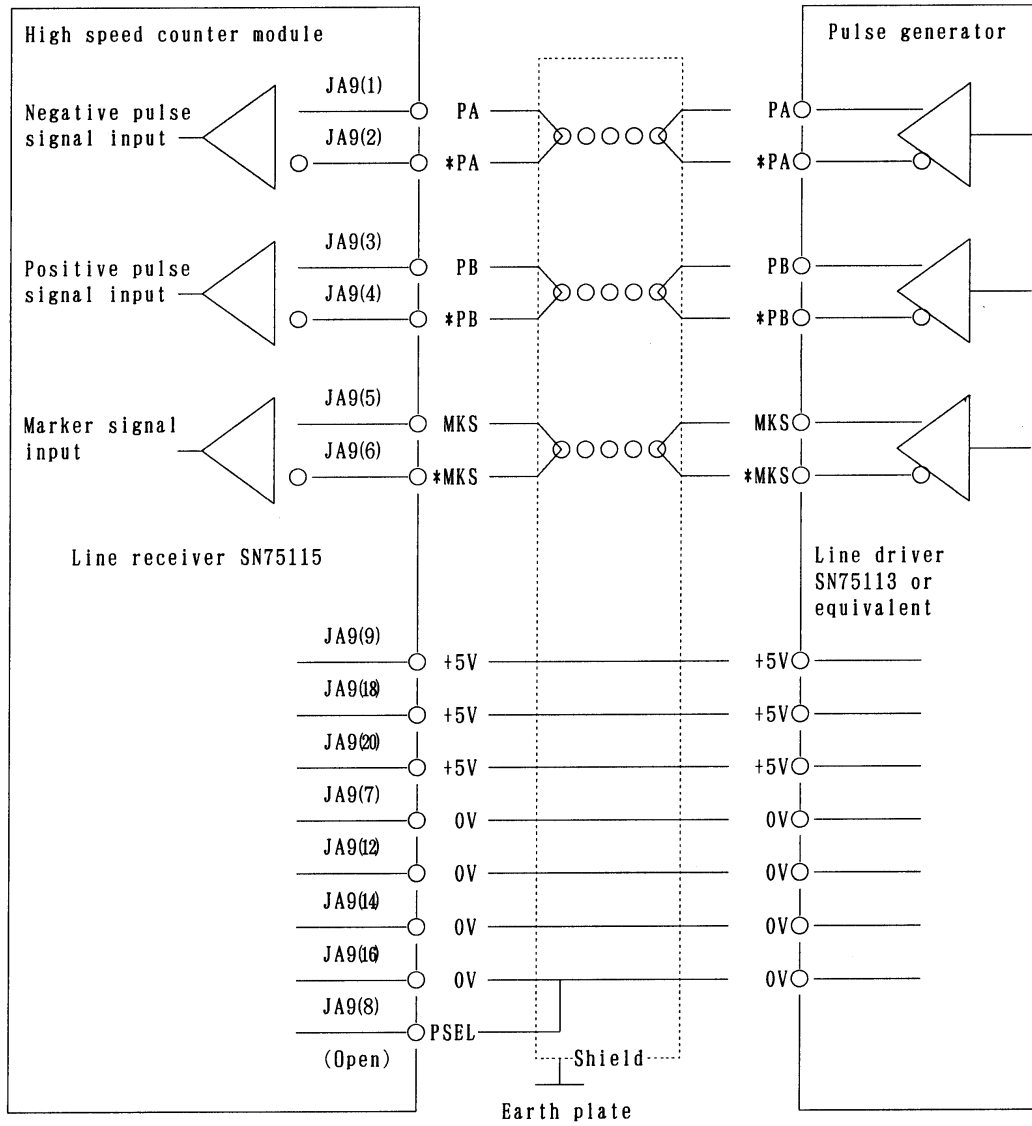

Recommended cable
 A66L-0001-0286 (#20AWG×8, #24AWG×3 Pairs)

8.6 CONNECTION WITH POWER MAGNETICS CABINET

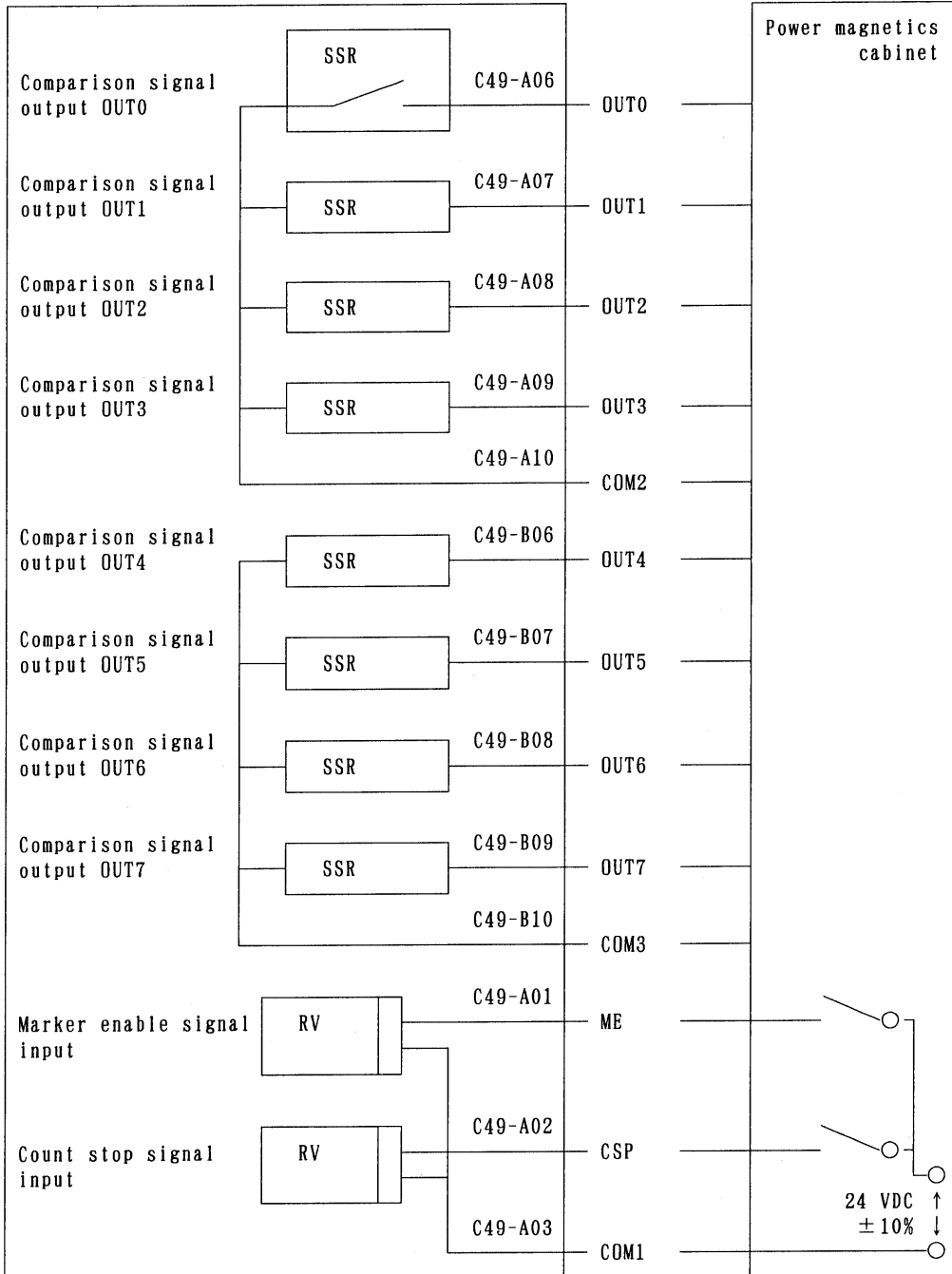

8.7 I/O SIGNALS CONVENTIONS

8.7.1 Solid state relay output signals (OUT0 to OUT7)

The solid state relay output signals drive relays in the power magnetics cabinet and indicator LEDs.

(1) Solid state relays

- i) Maximum load current at output-on
250 mA: Up to three outputs set to on
125 mA: Eight outputs set to on
- ii) Saturation voltage at output-on
Not more than $6 \times I_L$ V (IL: load current)
- iii) Withstand voltage at output-off
30 VDC max. even for instantaneous voltage
- iv) Leak current at output-off
Not more than $100 \mu\text{A}$

(2) Output circuit

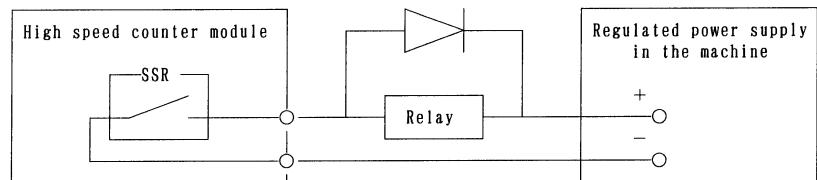

- (3) Always install spark arresters when inductive loads such as relays are connected in the machine. Insert the spark arresters as near the load as possible (less than 20 cm). When capacitive loads are used in the machine, insert current limiting resistors in series with the loads to prevent the instantaneous current and voltage from exceeding the rated values.
- (4) If a lamp is turned on by a solid state relay output, the resulting surge current may damage the solid state relay. Thus, as shown in the figure below, provide a protective resistor to prevent the instantaneous current and voltage from exceeding the rated values.

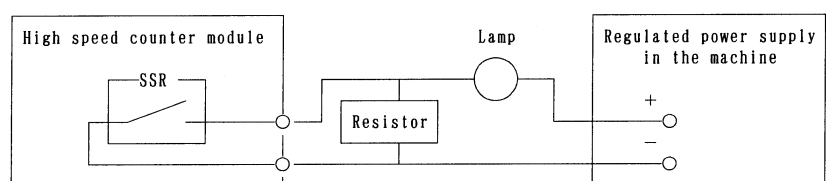

8.7.2 DC input signals (ME and CSP)

The DC input signals (such as relay contact signal) are sent from the machine (control circuit) to the pulse counter module.

(1) Input conditions

On voltage and current: 15 VDC or more, 4.5 mA or more

Off voltage and current: 6 VDC or less, 2 mA or less

Response time: 20 mA or less

(2) Voltage and polarity

Voltage : 24 VDC +10%, -20%

Polarity : Positive or negative polarity available (The power is not supplied from the pulse counter module.)

(3) Logical correspondence

| Contact | Logic |
|---------|-------|
| Open | 0 |
| Closed | 1 |

(4) Receiver circuit of DC input signal

Machine Pulse counter module

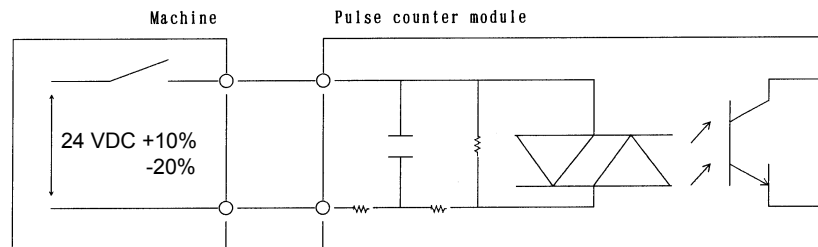

8.8 SUPPLEMENT

8.8.1 Configuration of mode A

How mode A is configured is shown below. The contents of the CNTS, CNTM, CNTL, and STTS on a high-speed counter module are sent to the X area assigned on the master via the I/O link. The contents of the Y area assigned on the master are sent to CTRL, DTOH, DTOM, and DTOL on the high-speed counter module, via the I/O link.

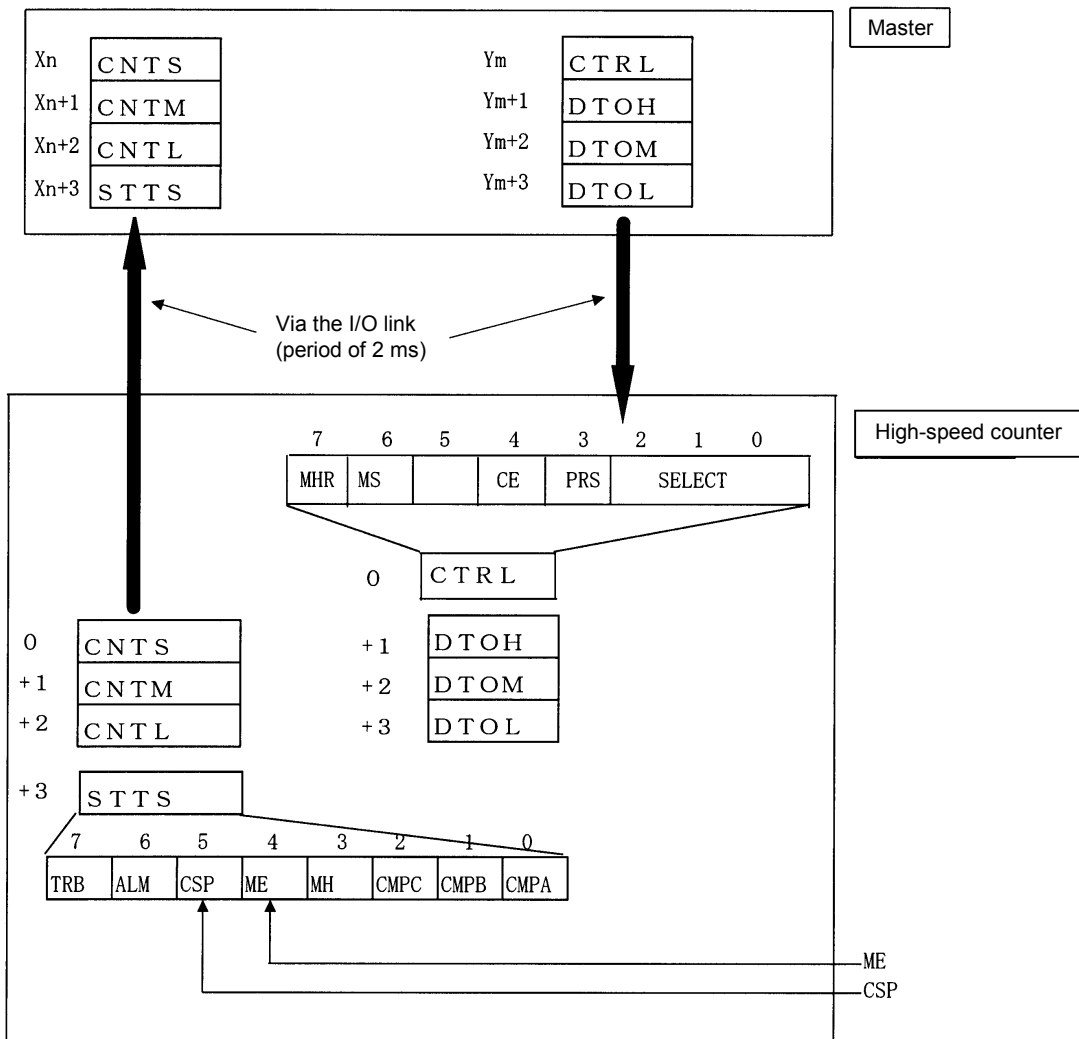

8.8.2 Counter presetting and counting

- (1) The following table lists the information related to counter presetting. The MH signal can be reset either by setting the MHR (bit 7) of the CTRL (control) to 1 or by resetting the MS (bit 6) of the CTRL to 0. See control examples 1 and 2.

| | Condition | | | | Status | |
|-------------------------|-------------|------------|-----------------------|------------------------|------------|------------|
| | MHR of CTRL | MS of CTRL | ME of external signal | MKS of external signal | ME of STTS | MH of STTS |
| Counter presetting | 0 | 1 | Contact "Closed" | Initial ↑ | 1 | 1 |
| MH signal resetting (1) | × | 0 | × | × | × | 0 |
| MH signal resetting (2) | 1 | × | × | × | × | 0 |

- Contact "Closed" means that 24 V is applied to the ME terminal.
- × means that the bit can be either 0 or 1. (× for the ME bit of the STTS means that the bit corresponds to the status of the ME bit of the external signal.)

Control example 1:

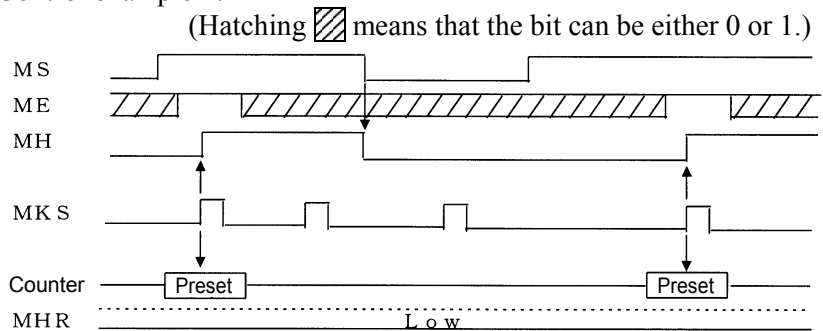

Control example 2:

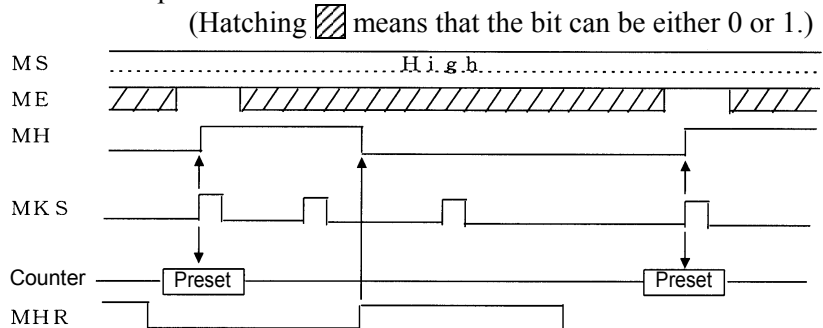

(2) Information related to counting

Counting starts and stops under the conditions listed below.

| | CE of CTRL | CSP of external signal | PSEL of external signal | CSP of STTS |
|-------------------------|------------|------------------------|-------------------------|-------------|
| Count (A/B phase pulse) | 1 | Contact "Open" | Open | 0 |
| Count (+/- pulse) | 1 | Contact "Open" | Connected to 0 V | 0 |
| Counting stop (1) | 0 | × | × | × |
| Counting stop (2) | × | Contact "Closed" | × | 1 |

- Contact "Closed" means that 24 V is applied to the CSP terminal. (1 or POS)
- Contact "Open" means that the CSP terminal is open. (0 or NEG)
- × means that the bit can be either 0 or 1. (× for the CSP bit of the STTS means that the bit corresponds to the status of the CSP bit of the external signal.)

8.8.3 Setting data

Data for some models (such as the FS15 and FS18) is in the opposite order to that of the NC data. In this case, convert (rearrange) the data in byte units.

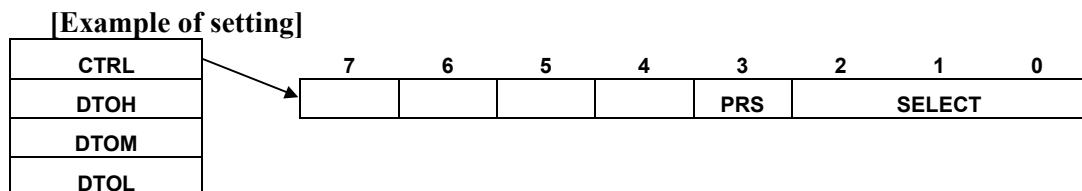

Example 1 : To preset the counter preset register with a specific value (the counter is also set to this value), follow the steps below.

- (1) Preset the DTOH, DTOM, and DTOL with a desired value.
- (2) Set SELECT to 001.
- (3) Reverse the setting of the PRS (from 0 to 1 or from 1 to 0).
- (4) Wait for two scanning periods.
 - Another method for presetting the counter is to use the MKS external signal (see Section 3.1). It takes a maximum of 5 ms to preset using the first method, while it takes only a maximum of 100 μ s to preset using the MKS external signal.

Example 2 : To set the comparison control register with the setting (0 or 1) of CMA, CMB, and CMC, follow the steps below.

- (1) Set DTOH bits 0, 1, and 2 to the desired data.
- (2) Set SELECT to 000.
- (3) Reverse the setting of the PRS (from 0 to 1 or from 1 to 0).
- (4) Wait for two scanning periods.

Example 3 : To set comparison register B to a desired comparison value, follow the steps below.

- (1) Set DTOH, DTOM, and DTOL to the desired comparison value.
- (2) Set SELECT to 011.
- (3) Reverse the setting of the PRS (from 0 to 1 or from 1 to 0).
- (4) Wait for two scanning periods.

The result of comparing comparison registers A, B, and C with the pulse counter is output via OUT0 to OUT2 of connector C49 of this counter module (A → OUT0, B → OUT1, and C → OUT2).

Their output status is output via OUT0 to OUT2 of the LED indication panel (A → OUT0, B → OUT1, and C → OUT2).

The result of comparison can be confirmed by checking STTS bits 0, 1, and 2 (CMPA, CMPB, and CMPC) with the PMC.

8.8.4 Reading data

The CNTS and STTS are two of the four input bytes. The most significant bit, TRA, of the CNTS and the most significant bit, TRB, of the STTS can be used to determine whether the count data is correct. If both TRA and TRB are 0 or 1, the count data is correct. In almost all cases, both TRA and TRB will be 0 or 1 when you view the diagnostic display. (Do not determine that the data has not changed because of the fact that the TRA and TRB do not become 0 or 1 alternately.) Note that the count data does not take a negative value.

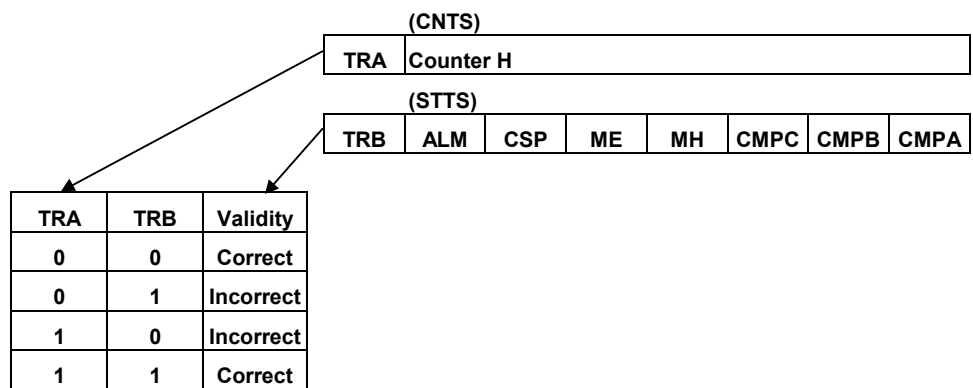

The counter assumes the following data when it is incremented or decremented.

- 0000000 00000000 00000010
 - 0000000 00000000 00000001
 - 0000000 00000000 00000000
 - 11111111 11111111 11111111
- to
- 0000000 00000000 00000011
 - 0000000 00000000 00000010
 - 0000000 00000000 00000001
 - 0000000 00000000 00000000
 - 11111111 11111111 11111111
 - 11111111 11111111 11111110
 - 11111111 11111111 11111101
 - 11111111 11111111 11111100

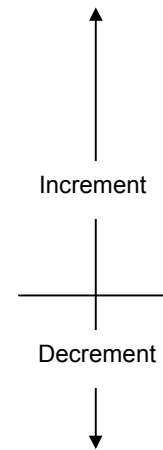

The square represents the TRA. (The most significant bit is the TRA. It is not a sign bit.)

8.8.5 Miscellaneous information

- (1) +5 V for connector JA9
- +5 V on connector JA9 of this high-speed counter module is output from the counter module (with a maximum current of 300 mA).
It is necessary to satisfy Table 4.4 in Section 4.4, "Required Current."
Example : When 100 mA is drawn from +5 V on connector JA9, $170 + 0.3 \times 100 = 200$. So, use 200 instead of 170.

- (2) Rotary encoder output
- Use a line driver output to drive the rotary encoder. Note that a voltage output or an open-collector output cannot be used for the rotary encoder. In addition, use a differential driver (SN75113 or equivalent) at the line driver output. Note that the AM26LS31 is equivalent to the SN75113.

- (3) Marker signal treatment
- When not using a marker signal (when not presetting), treat it as shown below. Otherwise, a disconnection alarm will occur. A disconnection alarm does not suspend counting.

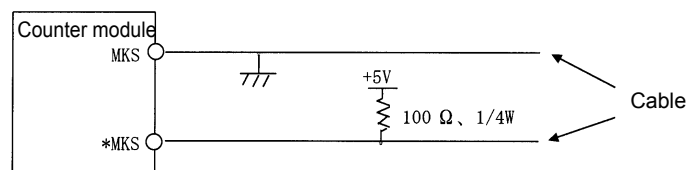

If this treatment does not prevent the disconnection alarm, check whether the GND point of the pulse generator is connected to the LGND (0 V) pin of connector JA9 on this high-speed counter module.

- (4) LED
- A/B phase pulse (+/- pulse) input signal indicators, A and B, correspond to pulse inputs A and B. When the pulse input is "1" (high), the indicator lights. If the pulse input has a very short period for "1" (high), it may difficult to recognize the indicator as being on.

9

TEMPERATURE INPUT MODULE

9.1 OVERVIEW

A temperature input module is used to measure the temperature of machine tools and similar equipment. The temperature input module can be either of the following, depending on the type of the sensor used.

- Thermoresistance-type temperature input module: ATI04A
- Thermocouple-type temperature input module: ATI04B

These modules can measure temperature on up to four channels. For the thermoresistance-type temperature input module, either JPt100Ω or Pt100Ω can be selected. For the thermocouple-type temperature input module, either K or J thermocouple input can be selected. This selection is made using the PMC user program (ladder).

9.2 TEMPERATURE INPUT MODULE SPECIFICATION

| | |
|-------------------------------------------------|------------------------------------------------------------------------------------------------------------------------------------------------------------------------------------------------------------------------------------------------------------------------------------------------------------------------------------------------------------------------------------------------------------------------------------------------------------------------------------------------------------------------------------------------------------------------------------------------------------------------------------------------------------|
| Input signal types and number of input channels | <ul style="list-style-type: none"> • Types <ul style="list-style-type: none"> ATI04A <ul style="list-style-type: none"> Three-wire thermoresistance (JPt100Ω) Three-wire thermoresistance (Pt100Ω) ATI04B <ul style="list-style-type: none"> J thermocouple (can also be used with the tip grounded) K thermocouple (can also be used with the tip grounded) • Number of input channels <ul style="list-style-type: none"> 2/4, for all for which the input is the same |
| Input signal switching method | <ul style="list-style-type: none"> • User program (ladder) |
| Temperature measurement range and precision | <ul style="list-style-type: none"> • Thermoresistance type (ATI04A) <ul style="list-style-type: none"> -50 to 300.0°C Resolution 0.1°C Overall precision ±1%FS • Thermocouple type (ATI04B) <ul style="list-style-type: none"> 0 to 600.0°C Resolution 0.1°C Overall precision ±1%FS |
| Data sampling period setting (NOTE) | <ul style="list-style-type: none"> • 0.3 s per two channels • 0.5 s per four channels to 10 s per four channels (4 s per four channels is assumed if no specification is made) |
| System failure check | <ul style="list-style-type: none"> • Self-diagnosis <ul style="list-style-type: none"> A watchdog timer is used. • Abnormal temperature (including sensor input disconnection) <ul style="list-style-type: none"> Failure information about each abnormal channel is sent to the PMC. |
| Interface with the PMC | <ul style="list-style-type: none"> • PMC → temperature module <ul style="list-style-type: none"> Information format: Binary or bit Signals: 32 points • Temperature module → PMC <ul style="list-style-type: none"> Information format: Binary or bit Signals: 32 points |
| External connection | Connector (Hirose Electric Co., Ltd.: HIF3BA-34PA-2.54DS) |

NOTE

The actual response time is the sum of the time required for the signal to pass the filter and the scan time that is determined depending on the system1

9.3 PMC INTERFACE

9.3.1 PMC I/O area

This temperature module uses an input/output area consisting of four bytes for input and the same number of bytes for output. Each byte of the input/output area has the following meanings. The terms "input" and "output" are used in reference to the PMC. When input/output addresses are assigned to the module, "/4" is used as the module name.

- 1) Output (PMC → temperature module)

Addresses in the module

| | | |
|----|--------------|-----------------------------------------------------------------|
| 0 | DO07 to DO00 | Period for 4-channel automatic measurement mode (lower 8 bits) |
| +1 | DO15 to DO08 | Period for 4-channel automatic measurement mode (higher 8 bits) |
| +2 | DO23 to DO16 | Module setting data and timing data |
| +3 | DO31 to DO24 | Module setting data and timing data |

- 2) Input (temperature module → PMC)

Addresses in the module

| | | |
|----|--------------|---------------------------------------------------------------------------------|
| 0 | DI07 to DI00 | CH1 temperature data, CH3 temperature data, or abnormality data (lower 8 bits) |
| +1 | DI12 to DI08 | CH1 temperature data, CH3 temperature data, or abnormality data (higher 5 bits) |
| | DI15 to DI13 | Status signal |
| +2 | DI23 to DI16 | CH2 temperature data, CH4 temperature data, or abnormality data (lower 8 bits) |
| +3 | DI28 to DI24 | CH2 temperature data, CH4 temperature data, or abnormality data (higher 5 bits) |
| | DI31 to DI29 | Status signal |

NOTE

If you are using the PMC-N, NA, or QA (the PMC for Series 15 or F-D Mate), all addresses up to those listed above can be used without modifying them if the data is manipulated in byte (8-bit) units. When manipulating data in word (16-bit) units, note that the byte addresses are transposed as shown below.

Addresses for word-unit operation in the PMC-N, NA, and QA

| | |
|------------------------------------|------------------------------------|
| PMC → Temperature module | Temperature module → PMC |
| High-order bits Low-order bits | High-order bits Low-order bits |
| Addresses in the module | Addresses in the module |
| 0 DO07 to DO00 DO07 to DO00 | 0 DI07 to DI00 DI15 to DI08 |
| +2 DO23 to DO16 DO31 to DO24 | +2 DI23 to DI16 DI31 to DI24 |

9.3.2 Measurement mode

This temperature module can operate in any of the following three measurement modes. The mode to use can be selected using a user program (ladder).

- ③ 2-channel measurement mode
This mode uses two channels, CH1 and CH2, for measurement. Data on each channel is updated every 0.3 s.
- ③ 4-channel automatic measurement mode
This mode uses four channels, CH1 to CH4, for measurement. Input switching from CH1 and CH2 data to CH3 and CH4 data and vice versa is performed automatically. Data on each channel is updated at a specified interval, say, every 0.5 to 10 s.
- ③ 4-channel manual measurement mode
This mode uses four channels, CH1 to CH4, for measurement. The PMC can reference CH1 and CH2 data or CH3 and CH4 data at the desired timing.

9.3.3 Details of output signals (PMC → temperature module)

| | | | | | | | |
|------|------|------|------|------|------|------|------|
| DO07 | DO06 | DO05 | DO04 | DO03 | DO02 | DO01 | DO00 |
| DO15 | DO14 | DO13 | DO12 | DO11 | DO10 | DO09 | DO08 |
| | DO22 | | | DO19 | DO18 | DO17 | DO16 |
| | | | | | DO26 | DO25 | DO24 |

- 1) Before setting the module setting data bit (NC READY (DO16)) to "1", set the following bits.

 DO00 (LSB) to DO15 (MSB):
 Channel switching period for 4-channel automatic measurement mode
 These bits are set with a binary number representing the channel switching period for the 4-channel automatic

measurement mode. They need not be set for the 2-channel mode.

The period can be varied in a range between 0.5 s and 10 s. When setting the bits, use a value ten times the desired period.

(Example) 2 s → 20 (14h)

The valid data range is between 5 and 100 (64h). Any value out of this range is regarded as being 40 (28h), that is, 4 s. If nothing is specified, a period of 4 s is again assumed.

DO17 : Module type

This bit is set according to the type of the temperature module being used.

0 : Thermocouple-type module (ATI04B)

1 : Thermoresistance-type module (ATI04A)

DO18 : Sensor type

This bit is set according to the type of the temperature sensor being used.

• ATI04A

0 : Pt

1 : JPt

• ATI04B

0 : K

1 : J

DO19 : Reserved for future use

This bit must always be set to "0".

DO24 : Number of channels

This bit is used to specify the number of channels to be measured.

0 : 2 channels

1 : 4 channels (if 1 is selected, DO25 must also be used.)

DO25 : 4-channel mode specification

This bit is used to select the 4-channel mode to be used.

0 : Automatic measurement (the period is specified using DO00 to DO15.)

1 : Manual measurement (a request is issued using DO22 and DO26 at every data read.)

2) Timing data

DO16 : NC READY

When the power is switched on, this bit is set to "1" to cause the module setting data to be set in the temperature module.

The NC READY bit is enabled only once after the power is switched on. To rewrite the module setting data, switch the power off and then on again.

DO22 : READ request

This bit serves as the timing signal used in 4-channel manual measurement mode. Setting the bit to "1" issues a request for temperature data. When the input signal data READY signal becomes "1", read the temperature data.

This bit need not be set for 2-channel mode.

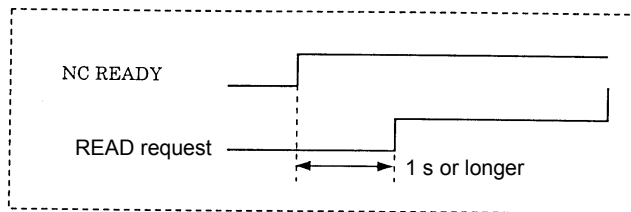

NOTE
After setting the NC READY bit to "1", wait for one second, and then set the READ request to "1".

DO26 : Channel select

This bit is used to specify channel switching for 4-channel manual measurement mode.

0: Channels 1 and 2

1: Channels 3 and 4

NOTE
See Section 9.5, "Timing Charts," for concrete explanations about how to handle the timing data.

9.3.4 Details of input signals (temperature module → PMC)

- 1) Status signals and CH1 temperature data, CH3 temperature data, or abnormality data

| | | | | | | | |
|------|------|------|------|------|------|------|------|
| DI07 | DI06 | DI05 | DI04 | DI03 | DI02 | DI01 | DI00 |
|------|------|------|------|------|------|------|------|

| | | | | | | | |
|------|------|------|------|------|------|------|------|
| DI15 | DI14 | DI13 | DI12 | DI11 | DI10 | DI09 | DI08 |
|------|------|------|------|------|------|------|------|

- Status signals
 - DI13 : Abnormality sign bit
 - 1 : This bit is set to "1" when the temperature input is abnormal. DI00 to DI12 are used to describe the abnormality.
 - 0 : DI00 to DI12 are used to indicate the temperature data.
 - DI14 : CH1 data READY
 - 1 : Read the CH1 temperature data from DI00 to DI12 when this bit is set to "1".
 - DI15 : CH3 data READY
 - 1 : Read the CH3 temperature data from DI00 to DI12 when this bit is set to "1".
- CH1 temperature data, CH3 temperature data, or abnormality data
 - DI00 (LSB) to DI12 (MSB):
 - These bits indicate temperature input data (CH1/CH3) or abnormality data.

Temperature input data

The temperature input data is in binary. It is ten times the actual temperature.

Example

(83EDh → 1005 → 100.5)

The highest three bits are status signals.

For the thermoresistance-type module (ATI04A), the DI12 bit is a sign bit. (Negative data is represented in two's complement.)

Example

(9F9Ch → -10.0)

The highest three bits are status signals.

Abnormality data

If an abnormality occurs in the input data or in the module, the DI13 bit (status signal) becomes "1", resulting in the display changing from temperature input data to abnormality data. Abnormality data is assigned to these bits as listed below:

- DI00 : CH1 input out of scale--the current temperature falls outside the measurable range.
- DI01 : CH1 input burn-out--the cable or connector has been detached.
- DI02 : CH3 input out of scale--the current temperature falls outside the measurable range.
- DI03 : CH3 input burn-out--the cable or connector has been detached.
- DI04 : Cold-junction abnormality (only for thermocouple-type input module)--the temperature of the terminal board unit falls outside the measurable range.

DI05 : System error--the internal circuit is abnormal.

DI06 : Wrong module--other than the correct module has been installed.

- 2) Status signals, CH2 temperature data, CH4 temperature data, or abnormality data

| | | | | | | | |
|------|------|------|------|------|------|------|------|
| DI23 | DI22 | DI21 | DI20 | DI19 | DI18 | DI17 | DI16 |
|------|------|------|------|------|------|------|------|

| | | | | | | | |
|------|------|------|------|------|------|------|------|
| DI31 | DI30 | DI29 | DI28 | DI27 | DI26 | DI25 | DI24 |
|------|------|------|------|------|------|------|------|

- Status signals

DI129 : Abnormality sign bit

1 : This bit becomes "1" when the temperature input becomes abnormal. DI16 to DI28 are used to describe the abnormality.

0 : DI16 to DI28 are used to indicate the temperature data.

DI30 : CH2 data READY

1 : Read the CH2 temperature data from DI16 to DI28 when this bit is set to "1".

DI31 : CH4 data READY

1 : Read the CH4 temperature data from DI16 to DI28 when this bit is set to "1".

- CH2 temperature data, CH4 temperature data, or abnormality data

DI16 (LSB) to DI28 (MSB):

These bits indicate temperature input data (CH2/CH4) or abnormality data.

Temperature input data

The temperature input data is in binary. It is ten times the actual temperature.

Example

(41F3h → 0499 → 49.9)

The highest three bits are status signals.

For a thermoresistance-type module (ATI04A), the DI28 bit is a sign bit. (Negative data is represented in two's complement.)

Example

(5FFBh → -0.5)

The highest three bits are status signals.

Abnormality data

If an abnormality occurs in the input data or the module, the DI29 bit (status signal) is set to "1", resulting in the display changing from temperature input data to abnormality data. Abnormality data is assigned to these bits as listed below:

- DI16 : CH2 input out of scale--the current temperature falls outside the measurable range.
- DI17 : CH2 input burn-out--the cable or connector has been detached.
- DI18 : CH4 input out of scale--the current temperature falls outside the measurable range.
- DI19 : CH4 input burn-out--the cable or connector has been detached.
- DI20 : Cold-junction abnormality (only for thermocouple-type input module)--the temperature of the terminal board unit falls outside the measurable range.
- DI21 : System error--the internal circuit is abnormal.
- DI22 : Wrong module--other than the correct module has been installed.

9.4 COMPLETE CONNECTION OF TEMPERATURE INPUT MODULE

9.4.1 Temperature input module connection diagram

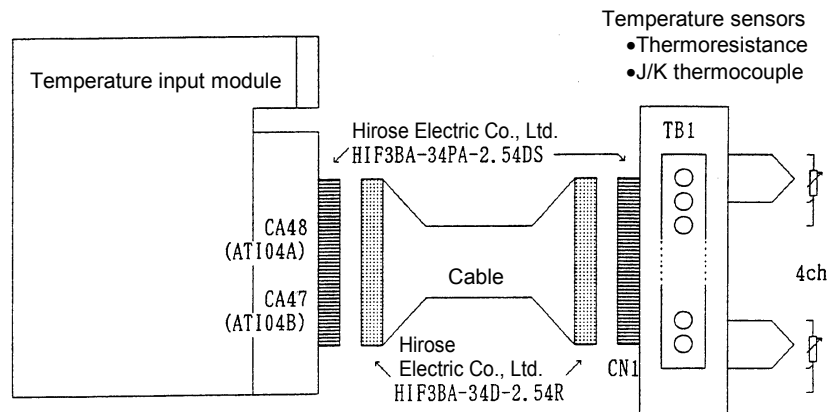

Terminal board unit

(There are two types of terminal board units, the first for a thermoresistance-type module and the second for a thermocouple-type module.)

See Section 9.7 for explanations about the dimensions of the terminal board.

9.4.2 Connector signal lists

- 1) Thermoresistance input module
ATI04A

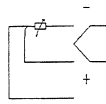

| Channel | Pin No. | Pin No. |
|-------------|---------|---------|
| Channel 1 - | 1A | 1B |
| Channel 1 + | 2A | 2B |
| Channel 1 + | 3A | 3B |
| Channel 2 - | 4A | 4B |
| Channel 2 + | 5A | 5B |
| Channel 2 + | 6A | 6B |
| Channel 3 - | 7A | 7B |
| Channel 3 + | 8A | 8B |
| Channel 3 + | 9A | 9B |
| Channel 4 - | 10A | 10B |
| Channel 4 + | 11A | 11B |
| Channel 4 + | 12A | 12B |
| Unusable | 13A | 13B |
| Unusable | 14A | 14B |
| Unusable | 15A | 15B |
| Unusable | 16A | 16B |
| Unusable | 17A | 17B |

- 2) Thermocouple input module
ATI04B



| Channel | Pin No. | Pin No. |
|---------------------------------------|---------|---------|
| Channel 1 - | 1A | 1B |
| Channel 1 + | 2A | 2B |
| Unusable | 3A | 3B |
| Channel 2 - | 4A | 4B |
| Channel 2 + | 5A | 5B |
| Unusable | 6A | 6B |
| Channel 3 - | 7A | 7B |
| Channel 3 + | 8A | 8B |
| Unusable | 9A | 9B |
| Channel 4 - | 10A | 10B |
| Channel 4 + | 11A | 11B |
| Unusable | 12A | 12B |
| Cold-junction compensation element A | 13A | 13B |
| Cold-junction compensation element B1 | 14A | 14B |
| Cold-junction compensation element B2 | 15A | 15B |
| Unusable | 16A | 16B |
| Unusable | 17A | 17B |

9.4.3 Terminal board unit connection diagram

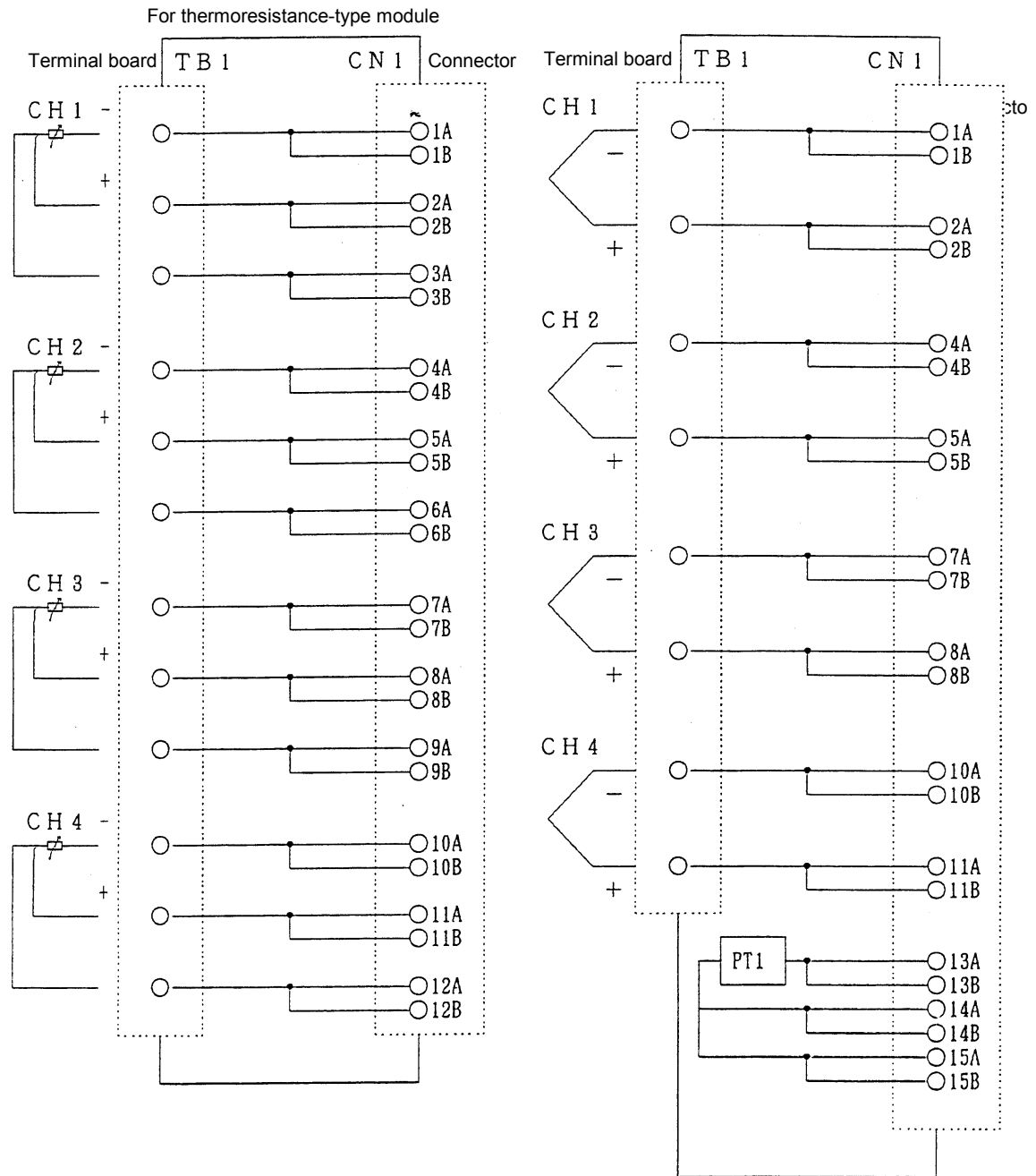

9.5 TIMING CHARTS

(1) 2-channel mode

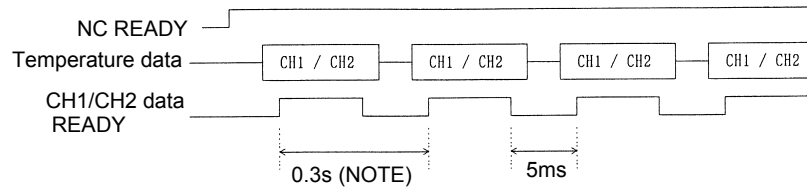

NOTE
 The actual response time is the sum of the time required to pass the filter and the scan time that is determined depending on the system.

(2) 4-channel automatic measurement mode

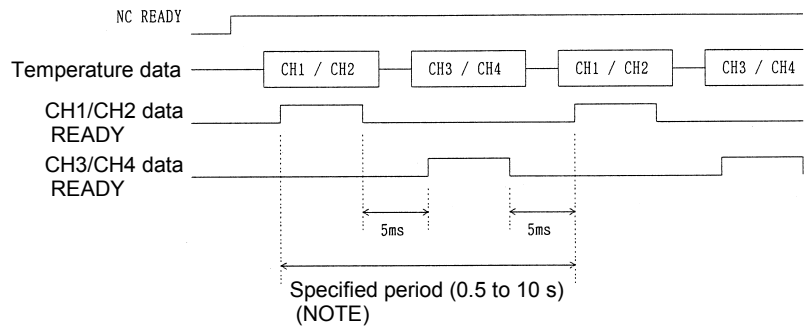

NOTE
 The actual response time is the sum of the time required to pass the filter and the scan time that is determined depending on the system.

(3) 4-channel manual measurement mode

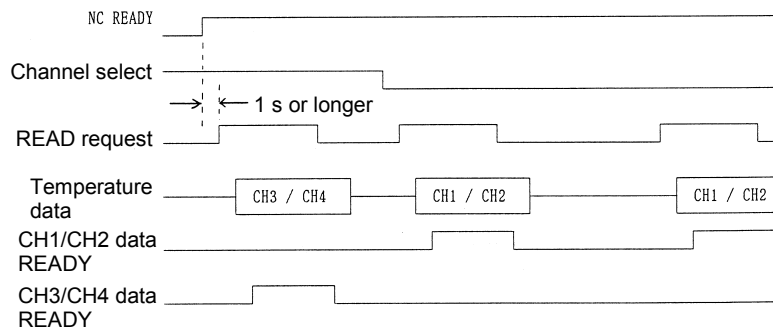

9.6 MEASUREMENT EXAMPLES

- (1) 2-channel mode
(a) Flowchart

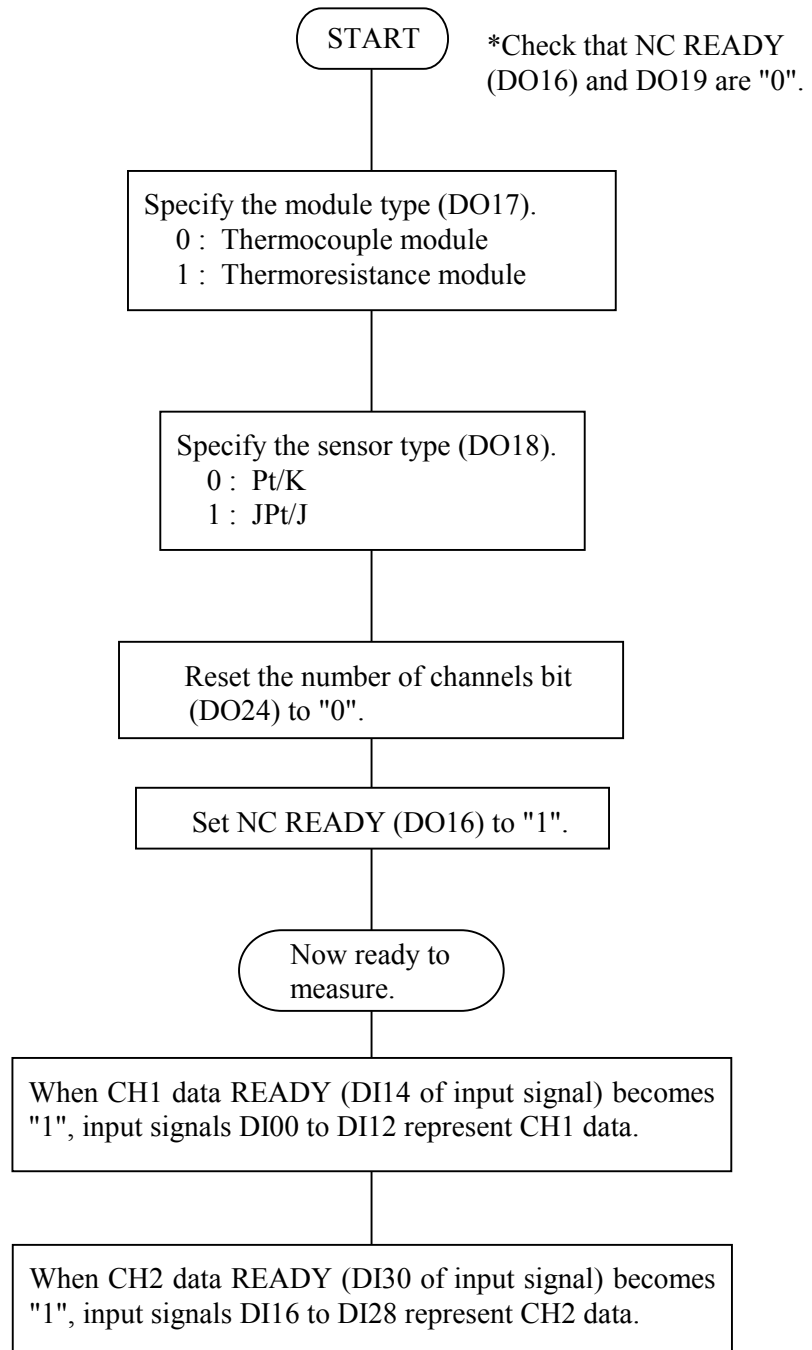

(b) Ladder example

The following measurement and ladder examples apply when a thermoresistance module with Pt is used for measurement.

PMC measurement

| | GROUP | BASE | SLOT | NAME | | GROUP | BASE | SLOT | NAME |
|------|-------|------|------|------|------|-------|------|------|------|
| X000 | 0 | 0 | 1 | /4 | Y000 | 0 | 0 | 1 | /4 |
| X001 | 0 | 0 | 1 | /4 | Y001 | 0 | 0 | 1 | /4 |
| X002 | 0 | 0 | 1 | /4 | Y002 | 0 | 0 | 1 | /4 |
| X003 | 0 | 0 | 1 | /4 | Y003 | 0 | 0 | 1 | /4 |

NOTE
 Set the ladder scan time to 0.25 s or less.
 This example of ladder use is for the second level.
 R0.0 is used as a normally open relay.

Ladder

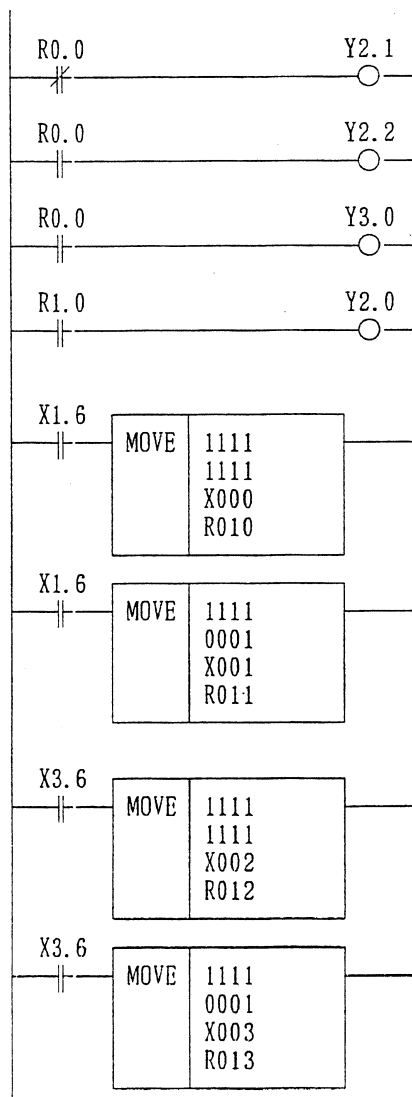

Specify the module.

(thermoresistance-type module)
 Specify the sensor (Pt).

Specify the number of channels (two channels).

NC READY (When R1.0 becomes "1", NC READY becomes "1" to start measurement.)

When CH1 data READY is "1", CH1 temperature data is sent to R010 to R011.

When CH2 data READY is "1", CH2 temperature data is sent to R012 to R013.

(2) 4-channel automatic measurement mode

(a) Flowchart

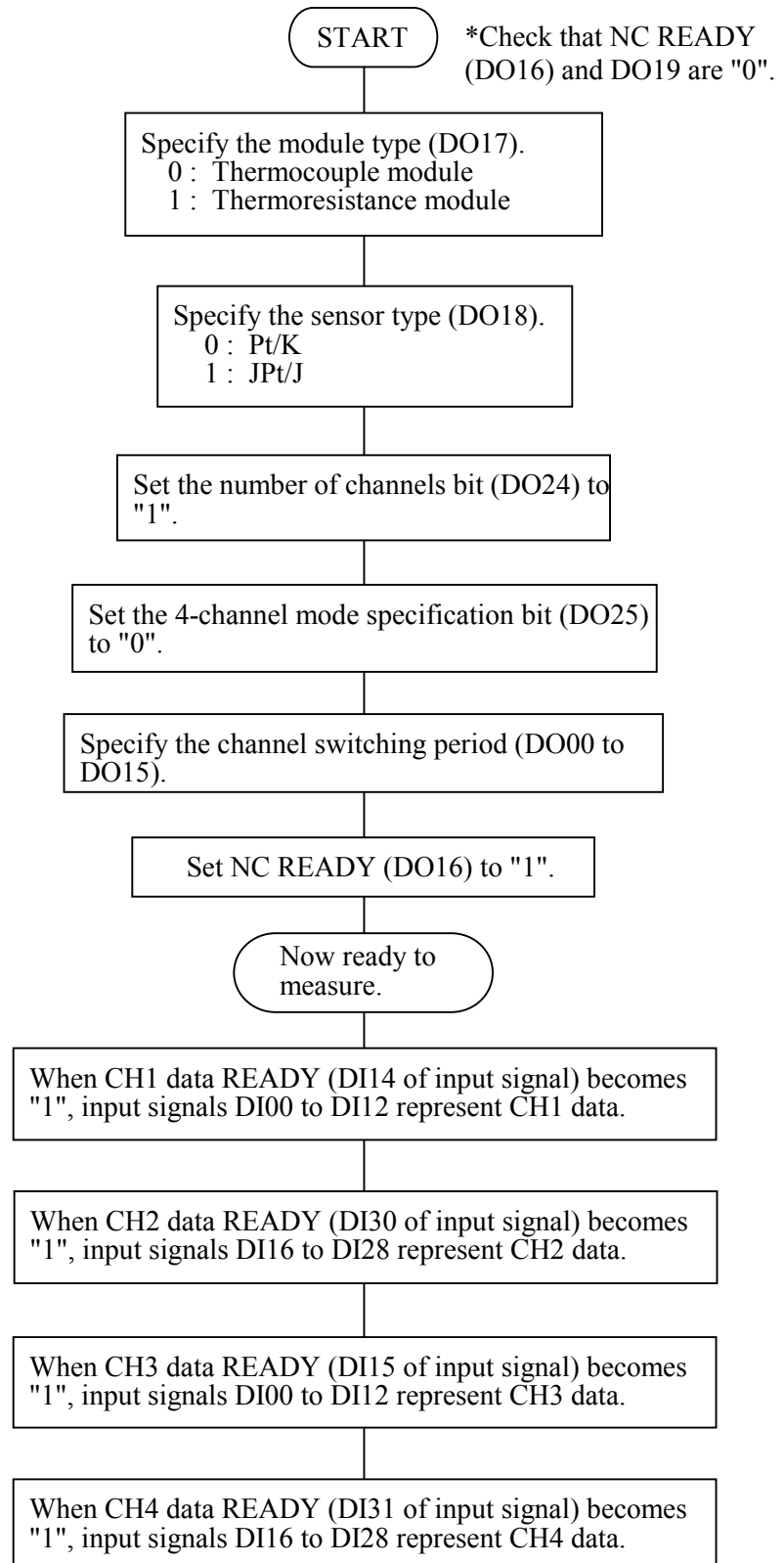

(b) Ladder example

The following measurement and ladder examples apply when a J thermocouple module is used for measurement.
PMC assignment

| | GROUP | BASE | SLOT | NAME | | GROUP | BASE | SLOT | NAME |
|------|-------|------|------|------|------|-------|------|------|------|
| X000 | 0 | 0 | 1 | /4 | Y000 | 0 | 0 | 1 | /4 |
| X001 | 0 | 0 | 1 | /4 | Y001 | 0 | 0 | 1 | /4 |
| X002 | 0 | 0 | 1 | /4 | Y002 | 0 | 0 | 1 | /4 |
| X003 | 0 | 0 | 1 | /4 | Y003 | 0 | 0 | 1 | /4 |

NOTE
This example of ladder use is for the second level.
R0.0 is used as a normally open relay.

Ladder

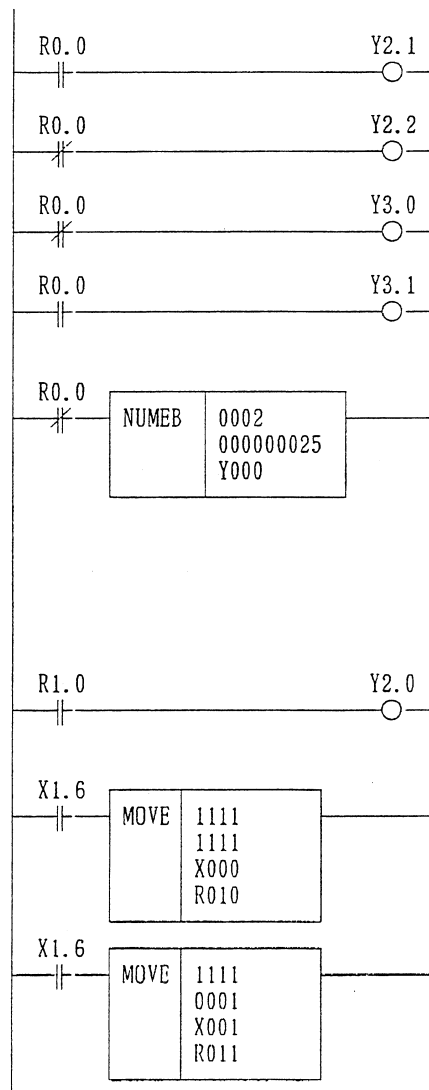

Specify the module.

(thermocouple-type module)
Specify the sensor
(J thermocouple).

Specify the number of channels
(four channels).

Specify a 4-channel mode
(automatic measurement).

Specify the channel switching
period for 4-channel automatic
measurement.
Specify 0025 to provide a period of
2.5 s.(NOTE)

NC READY (When R1.0 is set to "1",
NC READY becomes "1" to start
measurement.)

When CH1 data READY is set to "1",
CH1 temperature data is sent to
R010 to R011.

NOTE
 If your machine is the PMC-N, NA, or QA, specify 6400.
 0025 ⇒ 0019h. Because the upper byte is exchanged with the lower byte, 1900h ⇒ 6400.

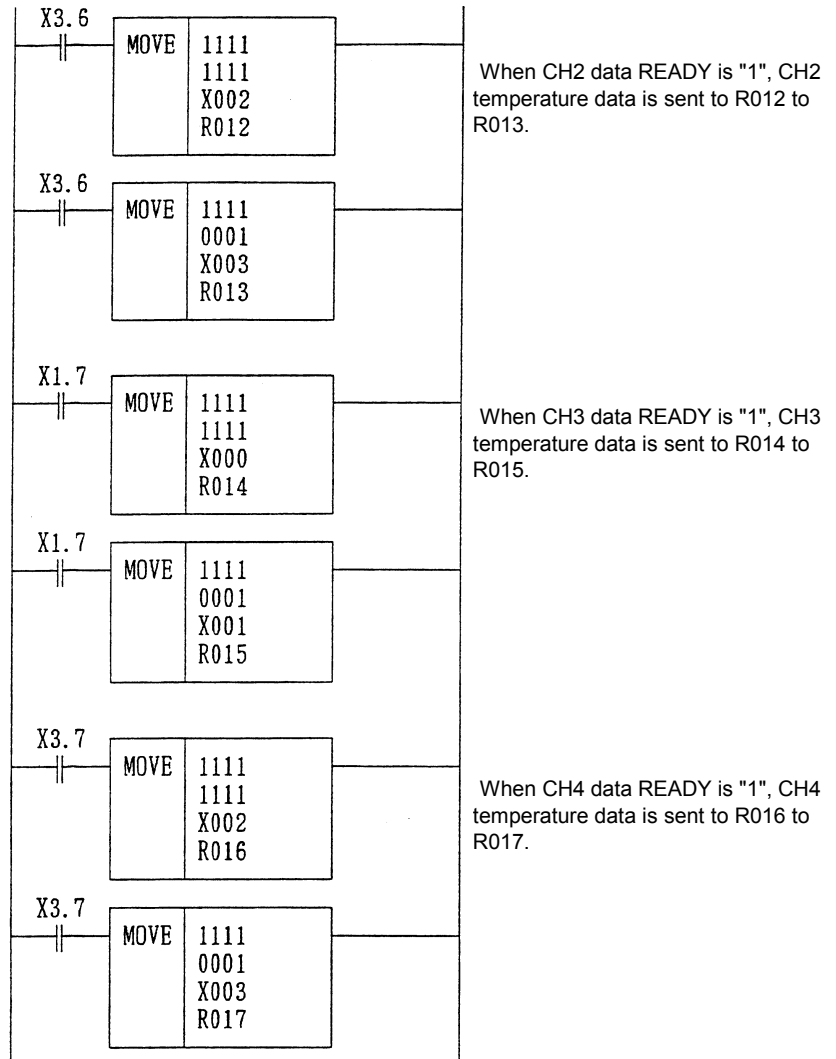

(3) 4-channel manual measurement mode

(a) Flowchart

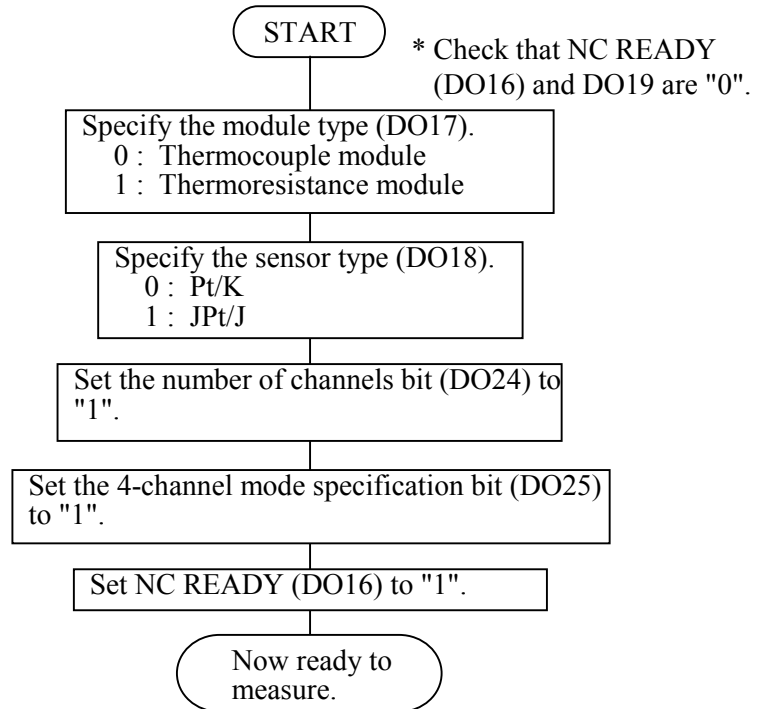

* Reading CH3 and CH4 data

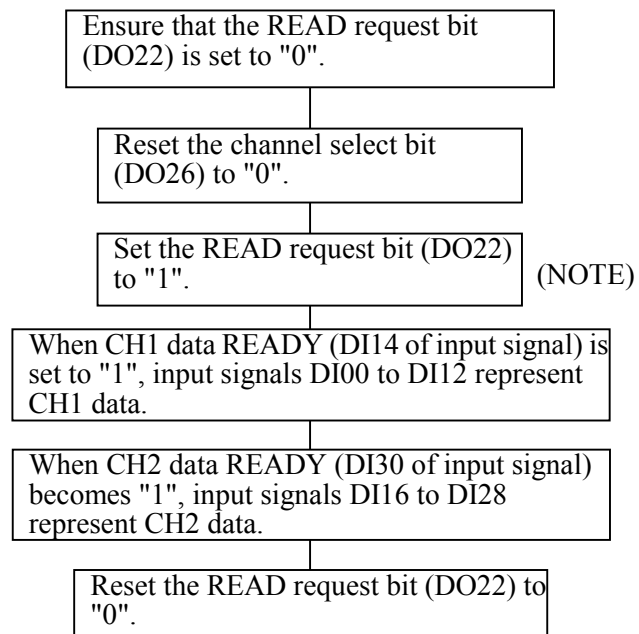

NOTE
After setting NC READY to "1", wait for one second, and then set the READ request to "1".

* Reading CH3 and CH4 data

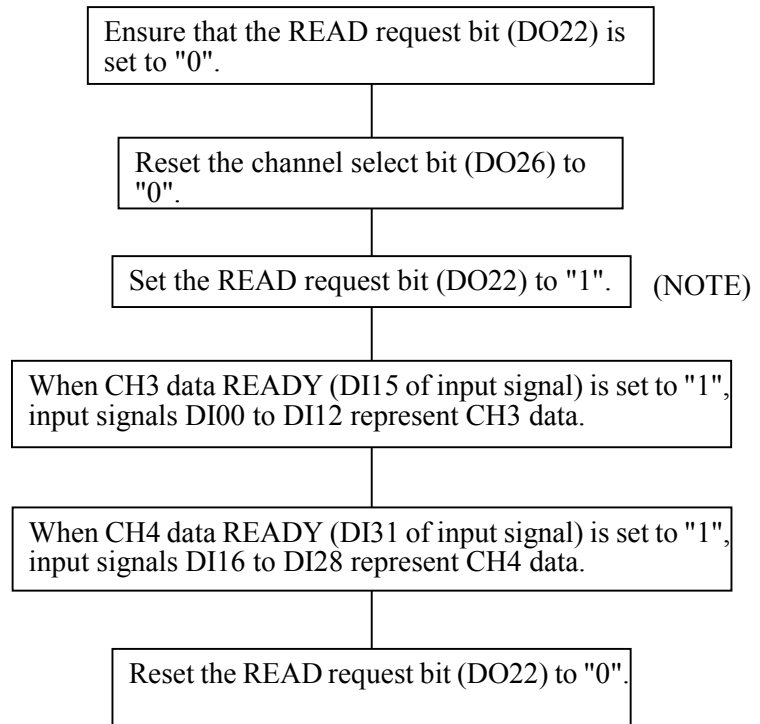

NOTE

After setting the NC READY bit to "1", wait for one second, and then set the READ request bit to "1".

To create the ladder for 4-channel manual measurement, refer to the above flowchart or timing chart.

9.7 TERMINAL BOARD UNIT DIMENSIONS

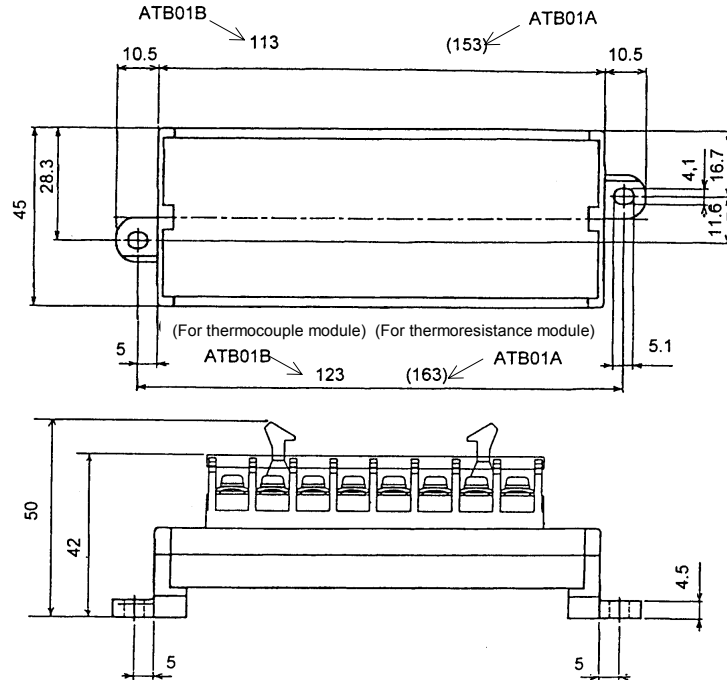

To use a DIN rail, add its height (tDIN) to the dimension shown below.

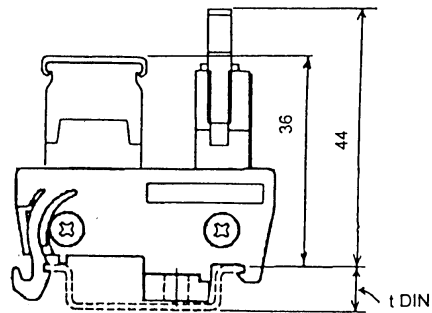

10 OPTICAL I/O LINK ADAPTER

The signal cable K1X shown in the general connection diagram (in section 4.1) can be extended to the maximum length of 200 m with optical fiber cables using an optical I/O link adapter.

NOTE

- 1 For the cable K2X, the optical I/O link adapter can not be applied to.
- 2 In the following cases, make sure to use an optical fiber cable for K1X.
 - When the cable is more than 10 meters long.
 - When the cable K1X runs between different cabinets and it is impossible to connect the cabinets with a wire of 5.5 mm² or thicker.
 - When there is concern that the cable K1X is influenced by strong noise.

For example;

When there is a strong electromagnetic noise source beside the cable K1X such as a welding machine and the like.

When a noise generating cable such as a power cable and the like runs for a long distance in parallel with the cable K1X.

10.1 EXTERNAL DIMENSION OF OPTICAL I/O LINK

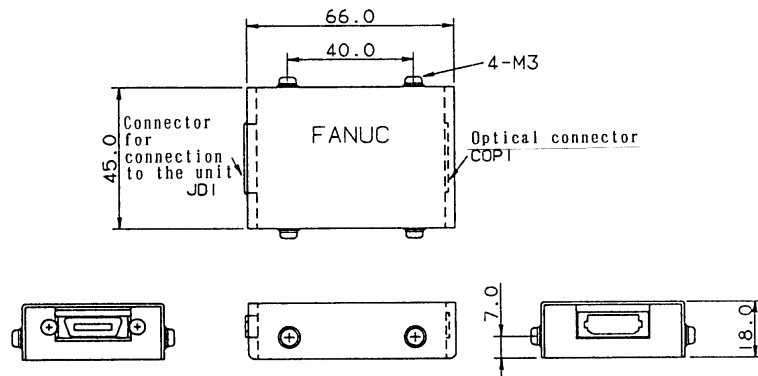

10.2 WEIGHT OF OPTICAL I/O LINK

- 1) Main body: Approx. 100g

10.3 CONNECTION OF OPTICAL I/O LINK

1) Connection diagram

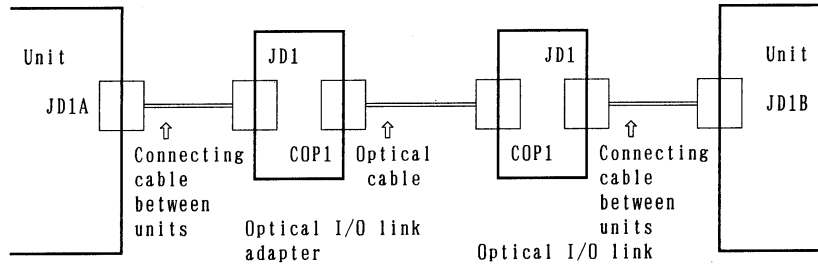

2) Interunit connecting cables

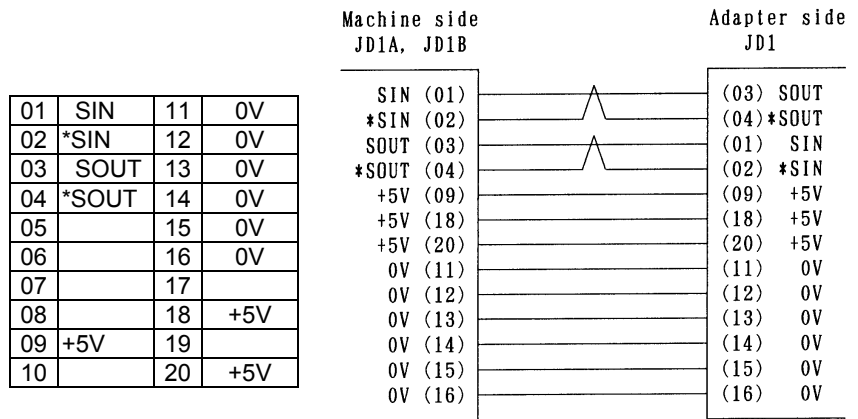

- ① Recommended connector for cable side:
PCR - E20FS (made by HONDA TSUSHIN Co.,Ltd.)
- ② Recommended cable (with material):
A66L-0001-0284#10P
- ③ Cable length:
Max.2m (when the recommended cable is used)

3) Optical cable

- ① Specification:
A66L-6001-0009(Make sure to use one with this specification)
- ② Cable length: Max.200m

10.4 POWER SOURCE OF OPTICAL I/O LINK ADAPTER

- 1) Power voltage: 4.75 V to 5.25 V (at the receiving end)
- 2) Consumption current: 200mA

10.5 INSTALLATION CONDITIONS OF OPTICAL I/O LINK ADAPTER

- 1) As this adapter is not a closed type, install it in the same closed type cabinet as used for the NC control unit.
- 2) Make sure to ground the case using the case fixing screw of the adapter.
- 3) As the adapter is light, it is not necessary to fix it with screws. However, keep it from getting contact with other circuits lest it should be short-circuited. In addition, when fixing the adapter in a cabinet and the like, fix it with a L-type fitting using the case fixing screws (M3) of the adapter.

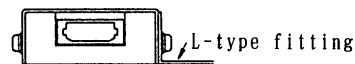

10.6 OPTICAL FIBER CABLE

This CNC uses optical cables for connections between the control unit and the I/O unit. Unlike the conventional power cables, optical fiber cables need special care in installation and handling.

10.6.1 External view of optical fiber cable

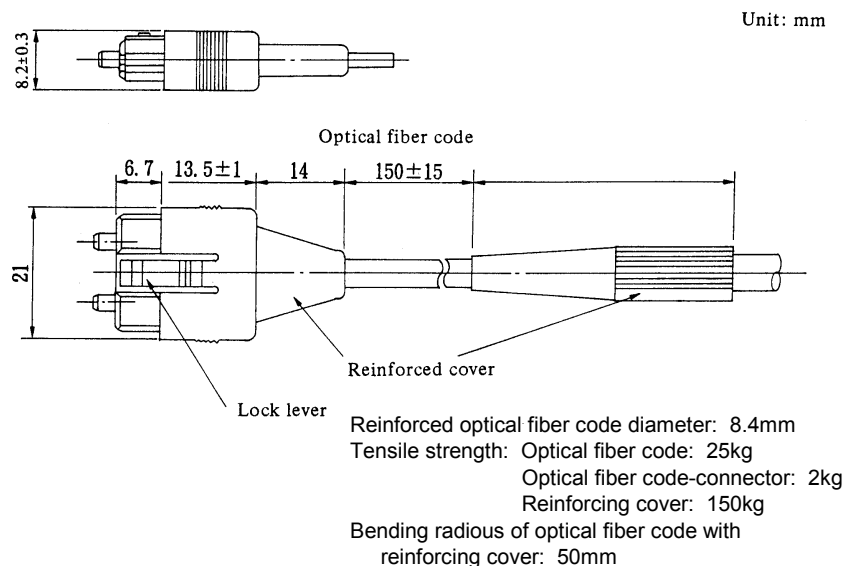

- (1) Standard length of an optical fiber cable is 5, 10, and 15 meters.
- (2) An optical fiber cable cannot be cut and joined at machine manufacturers side.
- (3) If it needs to relay on cabling, use optical fiber adapter. Up to the relay points are allowed on a transmission line.

10.6.2 Notice of optical fiber cable handling

- (1) Even though reinforcing cover used on the optical fiber code has enough mechanical strength, be sure not to be damaged by heavy materials drop.
- (2) Detaching and attaching of optical connector should always be made by touching connector. Optical fiber code should not be touched when replacement.
- (3) Optical connector is automatically locked with upper side lock levels after being connected. It is impossible to pull out the connector without releasing the lock levers.
- (4) Optical connector can not be connected oppositely. Be sure the connector direction when connection is done.
- (5) Optical connector should be processed as follows before laying of optical fiber cable.
 - Fix a reinforcing cover to a wire with hook or tension member by a tape. At laying hook the wire or pull the tension member taking enough care that optical connector does not receive pulling strength.

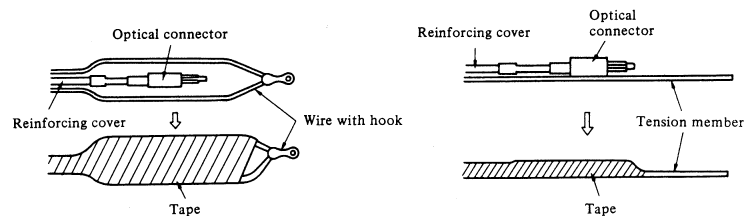

- (6) Reinforcing cover is fixed to cable lamp so that optical fiber cable could not weigh directly the connecting part of connector.
- (7) Notice that optical connector's chip is clear. The attached protect cap must be always put on when optical connector is not used. Remove dirty with a clear tissue or absorbent cotton (cotton with ethyl alcohol is applicable). No other organic solvent than ethyl alcohol can not be used.

10.6.3 Optical fiber cable clamping method

When reinforcing cover is fixed at cable clamp with sponge, enough sag at optical fiber code as shown below is necessary so that connecting part of optical should not be weighed directly by optical fiber cable.

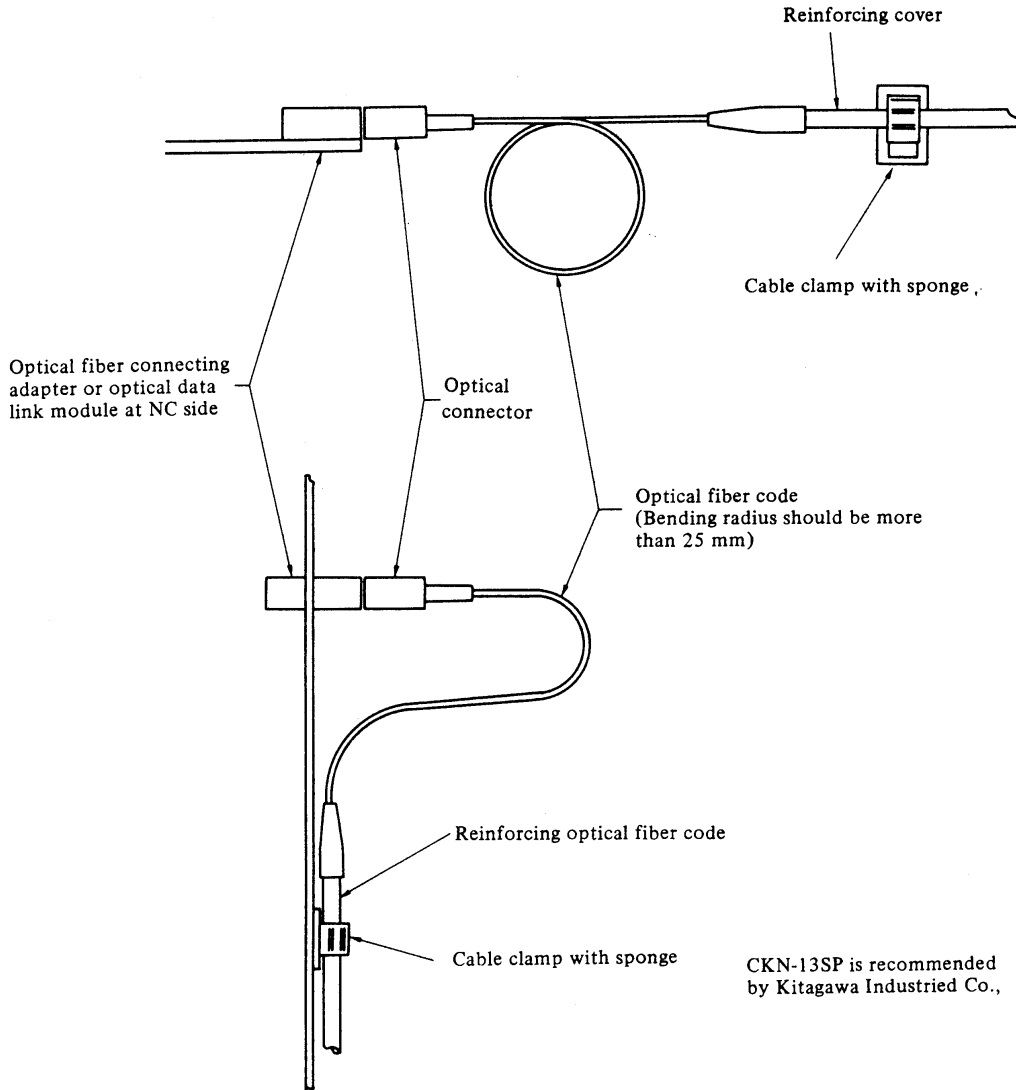

10.6.4 Relay using an optical fiber adapter

(1) External view of an optical fiber adapter

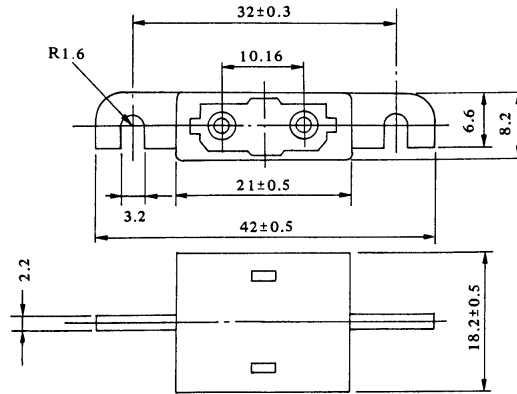

(2) Example of the use of an optical fiber adapter

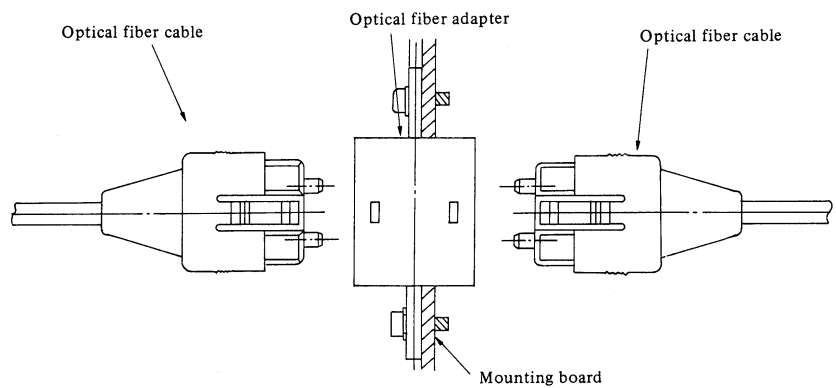

NOTE
Up to one relay points are permitted.

10.6.5 Maximum transmission distance by optical fiber cable

Maximum transmission distance by optical fiber cable is shown below:
Maximum transmission distance varies depend on numbers of relay points by optical fiber adapter.

| Relay points | Max. trans. distance (total) |
|--------------|------------------------------|
| 0 | 200m |
| 1 | 100m |

11 I/O LINK DUMMY UNIT

11.1 OVERVIEW

If a slave unit (such as the FS0, Power Mate, I/O Unit-MODEL A, or connection unit) is removed from the FANUC I/O Link (NOTE), the group number for those that followed the removed slave unit changes. So, it becomes necessary to change the PMC assignment. However, connecting a FANUC I/O Link dummy unit in place of the removed slave unit makes it unnecessary to change PMC assignment.

This document describes the electrical and structural specifications that apply to the FANUC I/O Link dummy unit when it is connected to the FANUC I/O Link.

NOTE

The FANUC I/O Link is a serial interface for connecting the CNC or cell controller to the I/O Unit-MODEL A, Power Mate, or other units for high-speed transfer of I/O signals (bit data).

11.2 EXTERNAL DIMENSIONS

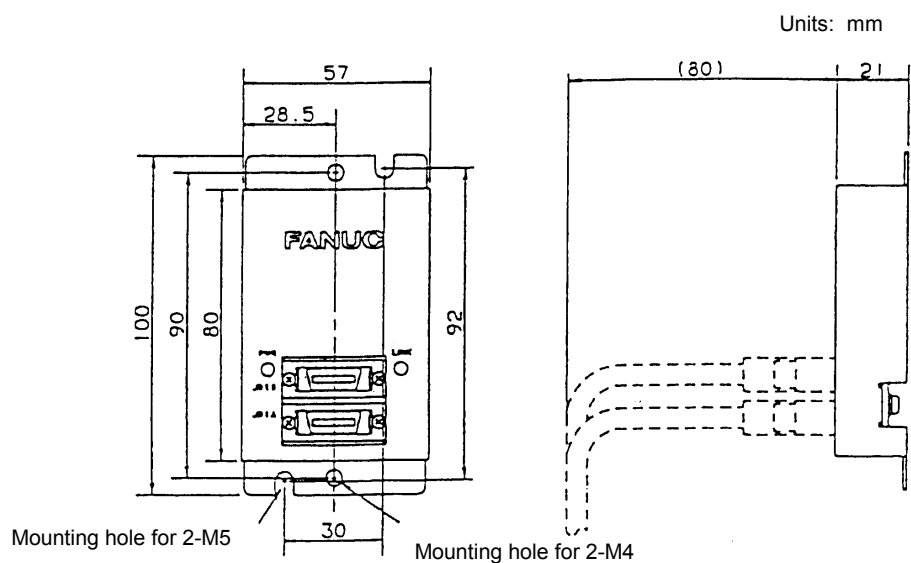

11.7 CONNECTION DIAGRAMS

11.7.1 When not connecting FANUC I/O Link dummy units in series

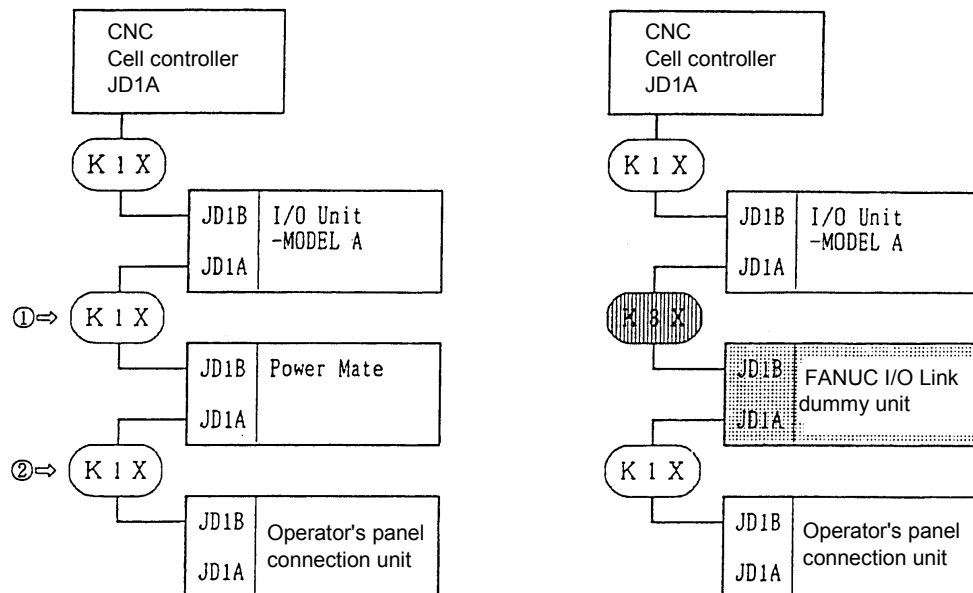

Fig. 11.7.1 Example of Using the FANUC I/O Link Dummy Unit
(in Place of the Power Mate)

- (1) Replacing a cable
The FANUC I/O Link dummy unit is supplied with power from the preceding or following group via a K3X cable. So, the K1X cable at either JD1A or JD1B of the dummy unit must be replaced with the K3X cable (① or ② in Fig. 11.7.1).

CAUTION

Do not attach a K3X cable to JD1A and JD1B simultaneously.

- (2) Cable length
K1X cable: 10 m (maximum)
K3X cable: 2 m (maximum)

11.7.2 Connecting FANUC I/O Link dummy units in series

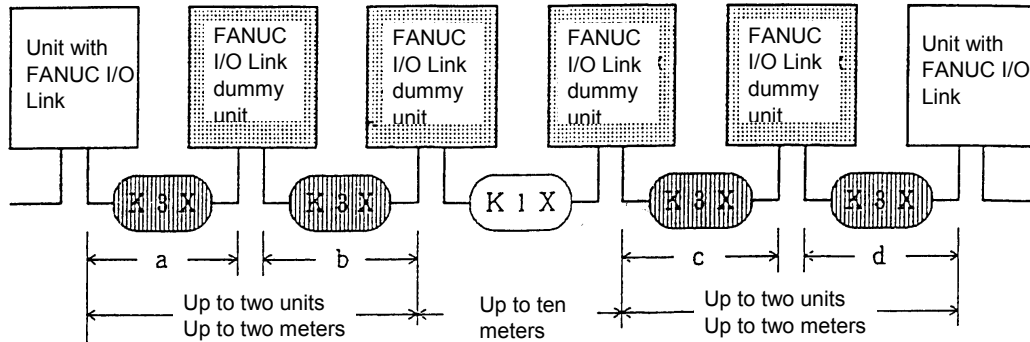

Fig. 11.7.2

- (1) Number of FANUC I/O Link dummy units that can be used in succession
Up to two FANUC I/O Link dummy units can be connected via a K3X cable to a unit that supplies power to them. (See Fig. 11.7.2.)
- (2) Cable length
K1X cable: 10 m (maximum)
K3X cable: 2 m (maximum) in total ($a + b \leq 2 \text{ m}$ and $c + d \leq 2 \text{ m}$)

11.7.3 Grounding

Ground the case of the FANUC I/O Link dummy unit.

11.7.4 K3X cable

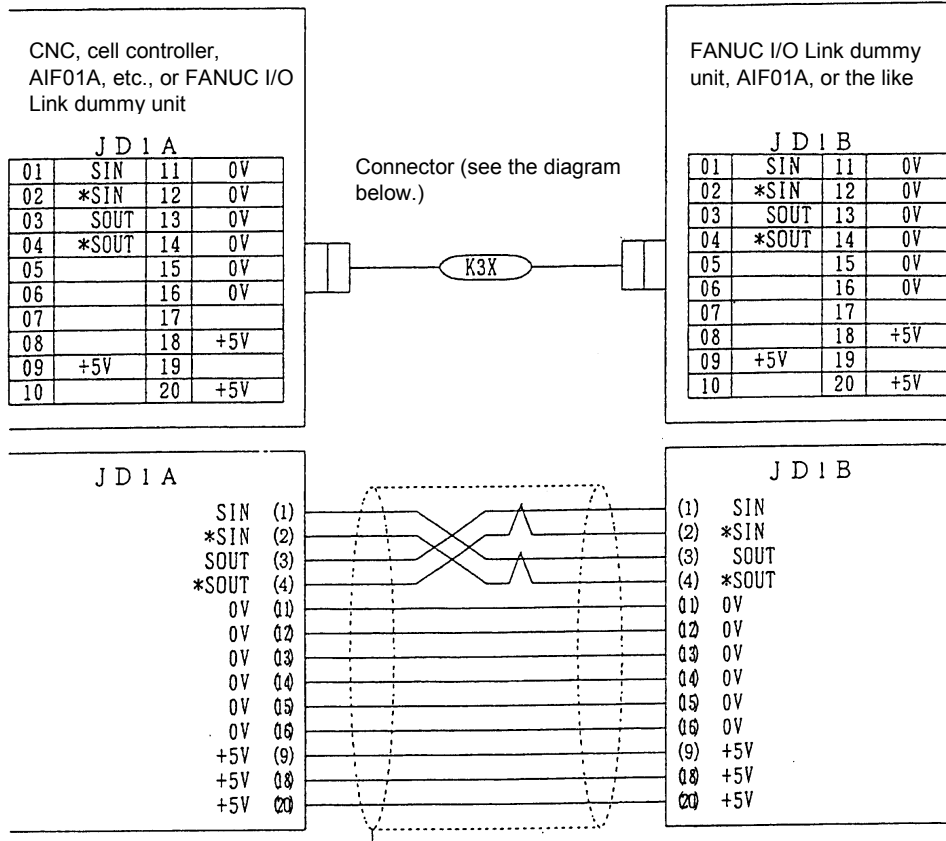

- Cable connector

| Manufacturer | Pin | | Housing |
|-----------------|----------------|-----------------|-----------------|
| | Soldering type | Crimping type | |
| Honda Tsushin | PCR-E20FS | PCR-E20FA | PCR-V20LA |
| Hirose Electric | FI-40-20S | FI-30-20S | FI-20-CV2 |
| Fujitsu | - | FCN-247J020-G/E | FCN-240C020-Y/S |

- Use twisted-pair wires for the SIN, *SIN, SOUT, and *SOUT signals.
- Recommended wires : A66L-0001-0284#10P (twisted-pair wires with common shielding)
- Maximum cable length : 2 m (when recommended wires are used)
- Do not connect a wire to an idle pin.
- Connect the cable shielding to the grounding plate of the cabinet via a metal cable clamp at JD1A. (See the applicable CNC or cell controller connection manual.)

12 SAFETY FOR USING AC

IF AC output module or AC input module is used, 12.1 is recommended for safety. IF 12.1 must be observed for Europe. [conforming to EN50178]

12.1 INSTALLATION ENVIRONMENT

12.1.1 Installation Category (Overvoltage Category)

The available impulse surge level to the ground that appears in the power source is 2.5kV maximum.

(100VAC system power source is needed in AC input module

According to the standard, the available impulse surge level to the ground is 1.5kV for this power source (voltage of which is 150VAC or less) However, for this module, the available impulse surge level to the ground that appears in the power source is 2.5 kV.)

Generally, an isolation transformer used for the main power source is regarded as an effective surge filter.

The class of the 16-point relay output module (AOR16G) is set to installation category (overvoltage category) I.

(Keep any impulse voltage to ground that may appear on the AC power to within 1.5 kV.)

The class for the 8-point relay output module (AOR08G), AC output module, and AC input module is set to installation category (overvoltage category) II.

12.1.2 Pollution Degree

Install the unit in the environment of pollution degree 2 or better.[EN50178]

In cabinet of IP-54 or better (described in 3.1), it can be considered as pollution degree 2 or better usually. The IP degree required is dependent on the circumstances of machine tool, so please choose the adequate degree in accordance with such environment.

II. MAINTENANCE

1 OVERVIEW

1.1 SYSTEM CONFIGURATION

I/O Unit-A is connected to a CNC and cell controller through a high-speed serial interface, I/O Link.

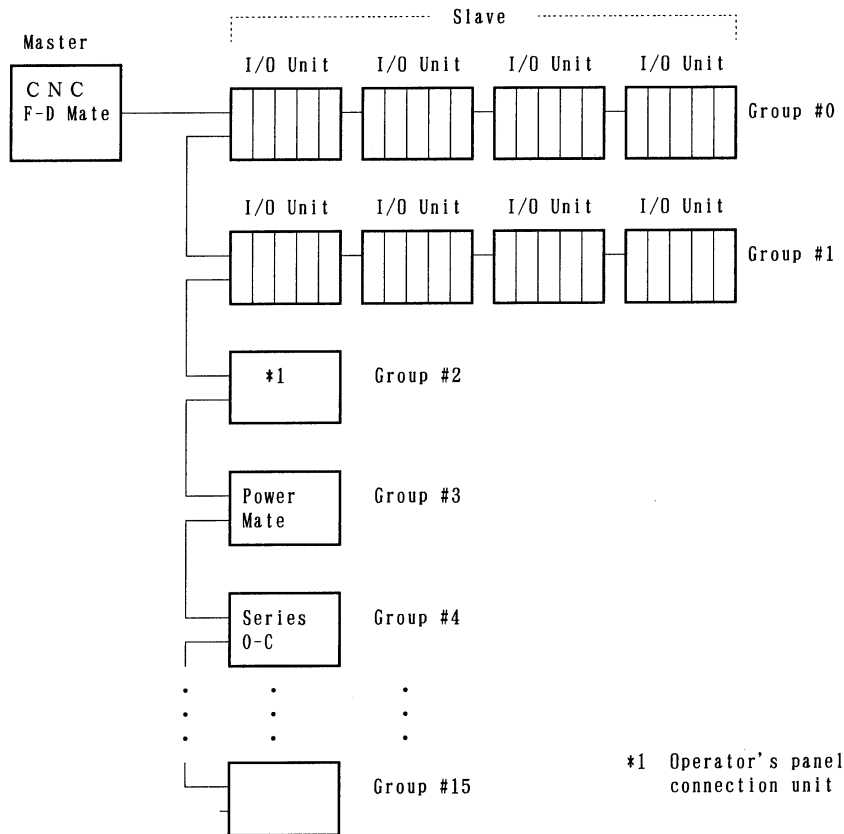

- 1) The I/O Link consists of a master and slaves.
 Master: Series 0-C, Series 15/16/18/20/21, Series 15i/16i/18i/20i/21i, Power Mate-D/H, Power Mate i-D/H and F-D Mate
 Slave: I/O Unit-A, Power Mate, operator's panel connection unit, and Series 0-C

- 2) One I/O Link can connect to up to 16 groups of slaves. If the master is not a CNC, one slave group can contain up to 4 of I/O Unit A (4 base units). If the master is a CNC or Power Mate the number of units per slave group is limited to within 2.

1.2 I/O UNIT-A CONFIGURATION

An I/O unit-A consists of a base unit, interface module, and I/O modules.

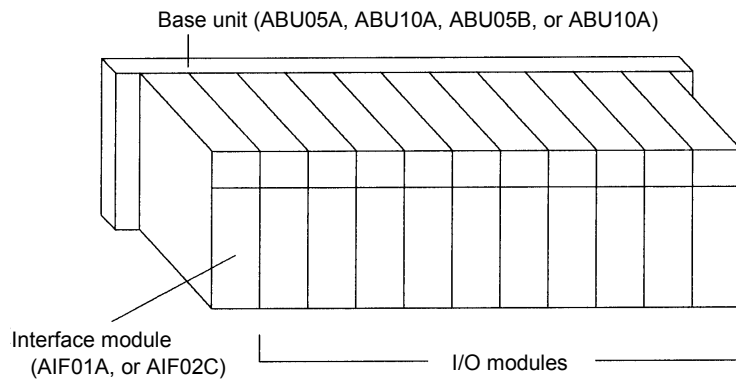

1.3 BLOCK DIAGRAM

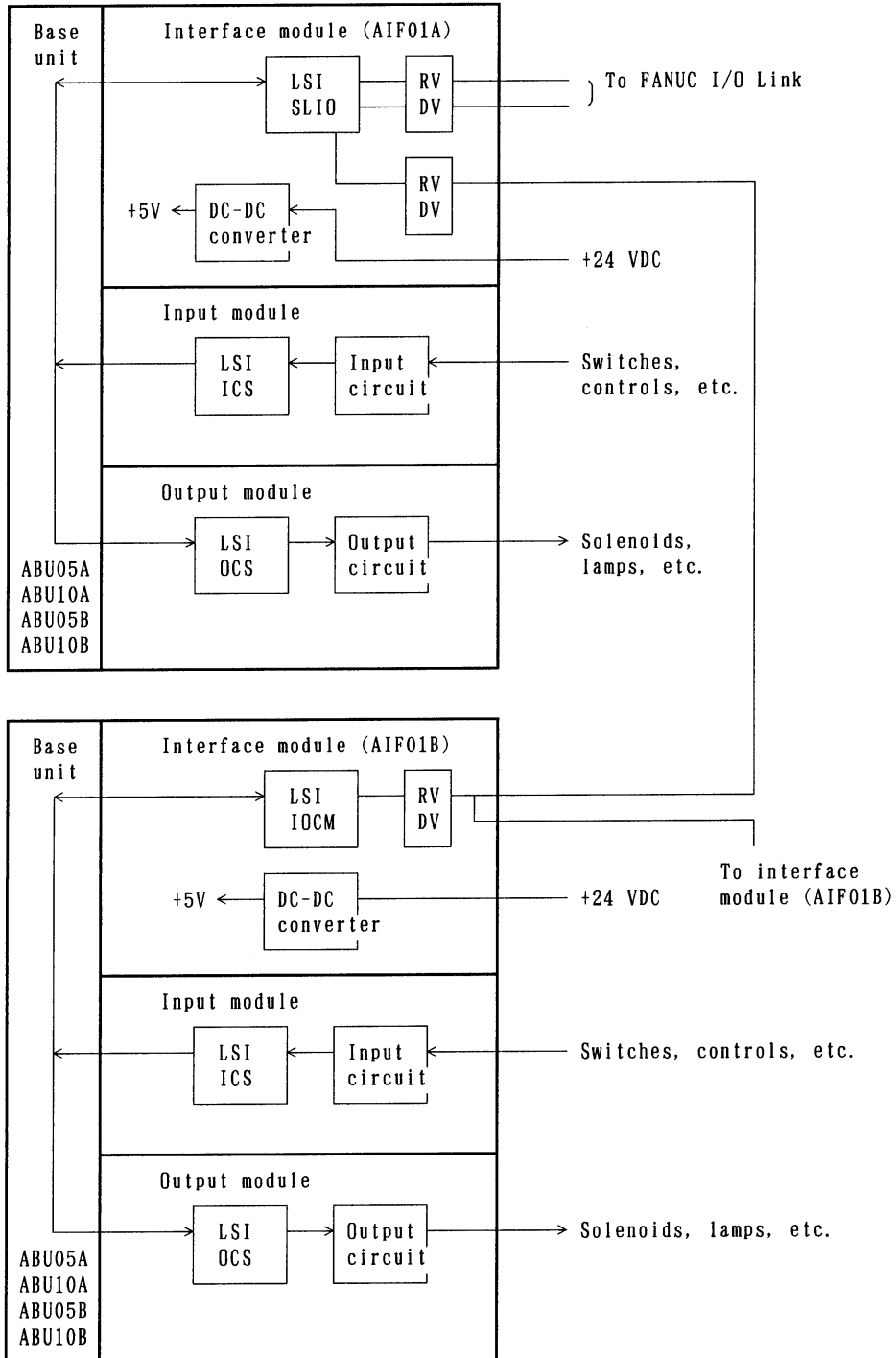

1.4 LIST OF UNITS

| Name | | | Arrangement drawing No. | Unit drawing No. | PCB drawing No. | | |
|------------------------|----------------------------|----------------------------------------|-------------------------|------------------|------------------------------------|------------------------------------|------------------------------------|
| Base unit. 10 slots | Horizontal type | ABU10A | A03B-0807-J001 | A03B-0807-C001 | A20B-9001-0040 | | |
| | Vertical type | ABU10B | A03B-0807-J004 | A03B-0807-C004 | A20B-2000-0550 or -2003-0100 | | |
| Base unit 5 slots | Horizontal type | ABU05A | A03B-0807-J002 | A03B-0807-C002 | A20B-2000-0020 | | |
| | Vertical type | ABU05B | A03B-0807-J003 | A03B-0807-C003 | A20B-9001-0510 | | |
| Interface module | | | AIF01A | A03B-0807-C011 | A20B-8000-0410 | | |
| Interface module | | | AIF01B | A03B-0807-C012 | A20B-8000-0420 | | |
| Interface module | | | AIF02C | A03B-0807-C013 | A20B-8000-0710 | | |
| DC input module | Non-insulations | 32 points. 20ms | AID32A1 | A03B-0807-J101 | A03B-0807-C101 | A20B-9000-0970 | |
| | | 32 points. 2ms | AID32B1 | A03B-0807-J102 | A03B-0807-C102 | A20B-9000-0971 | |
| | | 8 points. 2ms 24 points. 20ms | AID32H1 | A03B-0807-J111 | A03B-0807-C111 | A20B-9000-0972 | |
| | Insulations | 16 points. NEG, 20ms | AID16C | A03B-0807-J103 | A03B-0807-C103 | A20B-9000-0931 | |
| | | 16 points. POS, 20ms | AID16D | A03B-0807-J104 | A03B-0807-C104 | A20B-9000-0901 | |
| | | 16 points. NEG, 2ms | AID16K | A03B-0807-J113 | A03B-0807-C113 | A20B-9000-0932 | |
| | | 16 points. POS, 2ms | AID16L | A03B-0807-J114 | A03B-0807-C114 | A20B-9000-0902 | |
| | | 32 points. 20ms | AID32E1 | A03B-0807-J105 | A03B-0807-C105 | A20B-9001-0010 | |
| | | 32 points. 20ms | AID32E2 | A03B-0807-J110 | A03B-0807-C110 | A20B-9001-0280 | |
| | | 32 points. 2ms | AID32F1 | A03B-0807-J106 | A03B-0807-C106 | A20B-9001-0011 | |
| | | 32 points. 2ms | AID32F2 | A03B-0807-J109 | A03B-0807-C109 | A20B-9001-0281 | |
| | AC input module. 16 points | | | AIA16G | A03B-0807-J107 | A03B-0807-C107 | A20B-8000-0341 |
| | DC output module | Non insulations | 32 points. NEG | AOD32A1 | A03B-0807-J162 | A03B-0807-C162 | A20B-9001-0110 |
| | | Insulations | 8 points. NEG | AOD08C | A03B-0807-J151 | A03B-0807-C151 | A20B-9001-0210 or -9000-0951 |
| 8 points. POS | | | AOD08D | A03B-0807-J152 | A03B-0807-C152 | A20B-9001-0220 or -9000-0911 | |

| Name | | | Arrangement drawing No. | Unit drawing No. | PCB drawing No. | |
|-------------------------------|-------------|-----------------|-------------------------|------------------|-----------------|---------------------------------|
| DC output module | Insulations | 16 points. NEG | AOD16C | A03B-0807-J153 | A03B-0807-C153 | A20B-9000-0941 |
| | | 16 points. POS | AOD16D | A03B-0807-J154 | A03B-0807-C154 | A20B-9000-0921 |
| | | 32 points. NEG | AOD32C1 | A03B-0807-J155 | A03B-0807-C155 | A20B-9001-0070 |
| | | 32 points. NEG | AOD32C2 | A03B-0807-J172 | A03B-0807-C172 | A20B-9001-0530 |
| | | 32 points. POS | AOD32D1 | A03B-0807-J156 | A03B-0807-C156 | A20B-8000-0440 |
| | | 32 points. POS | AOD32D2 | A03B-0807-J167 | A03B-0807-C167 | A20B-8000-0510 |
| AC output module | | 5 points. 2A | AOA05E | A03B-0807-J157 | A03B-0807-C157 | A20B-8000-0470 or -8000-0251 |
| | | 8 points. 1A | AOA08E | A03B-0807-J158 | A03B-0807-C158 | A20B-8000-0480 or -8000-0381 |
| | | 12 points. 0.5A | AOA12F | A03B-0807-J159 | A03B-0807-C159 | A20B-8000-0321 |
| Relay output module | | 8 points. 4A | AOR08G | A03B-0807-J160 | A03B-0807-C160 | A20B-9001-0200 or -9000-0961 |
| | | 16 points. 2A | AOR16G | A03B-0807-J161 | A03B-0807-C161 | A20B-8000-0101 |
| | | 16 points. 2A | AOR16H2 | A03B-0807-J165 | A03B-0807-C165 | A20B-8000-0500 |
| Analog input module | | | AAD04A | A03B-0807-J051 | A03B-0807-C051 | A20B-8000-0450 |
| Analog output module (12-bit) | | | ADA02A | A03B-0807-J052 | A03B-0807-C052 | A20B-8000-0460 |
| Analog output module (14-bit) | | | ADA02B | A03B-0807-J060 | A03B-0807-C060 | A20B-8001-0980 |
| High speed counter module | | | ACT01A | A03B-0807-J053 | A03B-0807-C053 | A20B-8000-0540 |
| Temperature input module | | Pt/Pt | AT104A | A03B-0807-J056 | A03B-0807-C056 | A74L-0001-0083#Pt |
| | | J/K | AT104B | A03B-0807-J057 | A03B-0807-C057 | A74L-0001-0083#JK |
| Relay terminal unit | | Pt/Pt | ATB01A | A03B-0807-J350 | A03B-0807-C350 | A20B-1005-0920 |
| | | J/K | ATB01B | A03B-0807-J351 | A03B-0807-C351 | A20B-1005-0930 |
| Optical adapter | | | | A13B-0154-B0001 | - | A20B-1004-0240 |
| Dummy unit | | | | A13B-0167-B0001 | - | A20B-8000-0940 |

2

INDICATION

The interface modules and the I/O modules with up to 16 input/output points have LEDs to indicate their states.

2.1 INTERFACE MODULE (AIF01A) LEDs



| Marking | Name | Description | | | | | | | | | | | | | | | |
|------------|--------------|-----------------------------------------------------------------------------------------------------------------------------------------------------------------------------------------------------------------------------------------------------------------------------------------------------------------------------------------------------------------------------------------------------------------------------------------------------------------------------------------------------------------------------------------------------------------------------------------------------------------------------------------------------------------------------------------------------------------------------------------------------------------------------------------------------------------------------------------------------------------------------|-----|-----|-------------|---|---|---------|---|---|---------|---|---|---------|---|---|---------|
| PWR | Power-on | On: The interface module is supplied with power of 24 VDC. | | | | | | | | | | | | | | | |
| LINK | Link | On: The I/O Link is operating properly. Normally, this LED lights several to ten-odd seconds after the master is turned on. | | | | | | | | | | | | | | | |
| BA1 BA0 | Base address | <p>These LEDs indicate which base unit the interface module is transferring data with. If a failure occurs (the LINK LED is turned on, then off), BA0 or BA1, whichever is operating, is turned on.</p> <table border="1" style="margin-left: auto; margin-right: auto;"> <thead> <tr> <th>BA1</th> <th>BA0</th> <th>Base number</th> </tr> </thead> <tbody> <tr> <td style="text-align: center;">○</td> <td style="text-align: center;">○</td> <td>Base #0</td> </tr> <tr> <td style="text-align: center;">○</td> <td style="text-align: center;">●</td> <td>Base #1</td> </tr> <tr> <td style="text-align: center;">●</td> <td style="text-align: center;">○</td> <td>Base #2</td> </tr> <tr> <td style="text-align: center;">●</td> <td style="text-align: center;">●</td> <td>Base #3</td> </tr> </tbody> </table> <p style="text-align: right;">○ : Off ● : On</p> | BA1 | BA0 | Base number | ○ | ○ | Base #0 | ○ | ● | Base #1 | ● | ○ | Base #2 | ● | ● | Base #3 |
| BA1 | BA0 | Base number | | | | | | | | | | | | | | | |
| ○ | ○ | Base #0 | | | | | | | | | | | | | | | |
| ○ | ● | Base #1 | | | | | | | | | | | | | | | |
| ● | ○ | Base #2 | | | | | | | | | | | | | | | |
| ● | ● | Base #3 | | | | | | | | | | | | | | | |

Failures, their causes, and required actions

- 1) PWR is off.
 - ① Power (24 VDC) is not supplied or the supply voltage is abnormal.

⇒ Supply power of 24 VDC ± 10%.
 - ② A The fuse in the interface module has blown.

- ⇒ Eliminate the cause that made the fuse to blow, then replace the fuse with a spare. (See Section 3.) The following may cause the fuse to blow:
- A sum of power requirements for all input modules exceeds the rating. (Refer to I-4.4)
 - A voltage of +24 VDC, supplied from input module AID32A1, AID32B1 or AID32H1 to the outside, is short-circuited to the cabinet or the like.
 - The interface module or any of the I/O modules is defective.
- ③ An I/O module is defective.
- ⇒ Remove the I/O modules sequentially to pinpoint the defective one. Then, replace it with a spare.
- ④ An interface module is defective.
- ⇒ Replace it with a spare.
- 2) LINK has never been turned on since power is supplied.
- ① If PWR is off, go to item 1).
- ② The attempted power turn-on sequence was incorrect.
- ⇒ The slaves (I/O Unit-A, Power Mate, Series 0, etc.) must be supplied with power at the same time or before the master (CNC or F-D Mate) is supplied with power. (Refer to I-4.2)
- If an attempt is made to supply power to a slave on an interface module after the master is turned on, LINK on the interface module is not turned on provided that the interface module corresponds to that slave or to any slave ahead of that slave (one on the far side with respect to the master).
- ③ I/O Link cables are broken or short-circuited.
- ⇒ With reference to Note below, check the cables, and take an appropriate action.

④ Any device on the I/O Link is defective.

⇒ With reference to Note below, find a defective device, and take an appropriate action. If an I/O unit seems to be defective, replace interface module AIF01A with a spare.

NOTE

How to pinpoint a failure in the I/O Link in event of items ② to ④.

Check the LEDs on the master to find out which group contains slaves whose I/O Link is established with the master. (Refer to the maintenance manual for the master.)

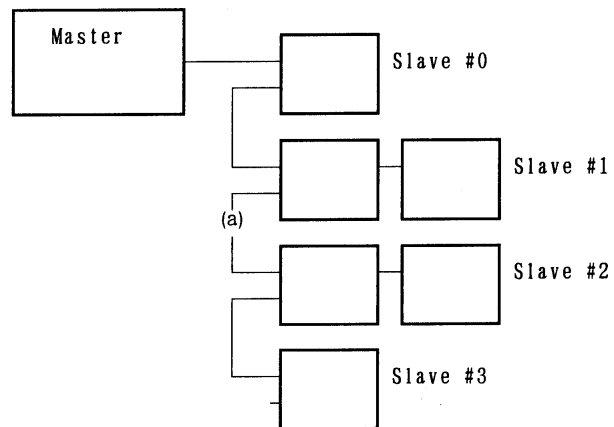

For example, if the master is linked to slaves (slave #0 and #1) that belong to separate groups, the timing of turning on slave #2 is bad, the cable is broken or short-circuited at point (a), slave #2 is defective.

If the master is not linked to any slave, the master may be defective.

3) LINK is turned on once, then off.

① One of the devices on the I/O Link is turned off.

⇒ Turn off all devices, then turn them on.

② The DI/DO assignment for the master is invalid.

⇒ When I/O unit bases 1 to 3 (units under control of interface module AIF01B) are not connected, if DI/DO units are assigned to these bases, LINK is turned on, but turned off immediately.
Correct the DI/DO assignment.

- ③ The I/O Link cable is broken or short-circuited.
 - ⇒ Check the cable, and take an appropriate action.
- ④ Any device on the I/O Link is defective.
 - ⇒ With reference to the maintenance manual for the master, find a defective device, and take an appropriate action. If an I/O unit seems defective, replace the interface module (AIF01A or AIF01B) installed in the base unit indicated by BA1 or BA0.

2.2 INTERFACE MODULE (AIF01B) LEDS



| Marking | Name | Description |
|---------|----------|-----------------------------------------------------------------------------------------------------------------------------|
| PWR | Power-on | On: The interface module is supplied with power of 24 VDC. |
| LINK | Link | On: The I/O Link is operating properly. Normally, this LED lights several to ten-odd seconds after the master is turned on. |

Failures, their causes, and required actions

1) PWR is off.

- ① Power (24 VDC) is not supplied or the supply voltage is abnormal.

⇒ Supply power of 24 VDC \pm 10%.

- ② The fuse in the interface module has blown.

⇒ Eliminate the cause that made the fuse to blow, then replace the fuse with a spare. (See Chapter 3.) The following may cause the fuse to blow:

- A sum of power requirements for all input modules exceeds the rating. (Refer to I-4.4)
- A voltage of +24 VDC, supplied from input module AID32A1, AID32B1 or AID32H1 to the outside, is short-circuited to the cabinet or the like.
- The interface module or any of the I/O modules is defective.

- ③ An I/O module is defective.

⇒ Remove the I/O modules sequentially to pinpoint the defective one. Then, replace it with a spare.

- ④ An interface module is defective.
 - ⇒ Replace it with a spare.
- 2) LINK has never been turned on since power is supplied.
 - ① If PWR is off, go to item 1).
 - ② If LINK on the AIF01A in the same group is off, go to Section 2.1.
 - ③ The signal cable between I/O units in the same group is broken or short-circuited.
 - ⇒ Check the cable, and take an appropriate action.
 - ④ An interface module is defective.
 - ⇒ Replace it with a spare.
- 3) LINK is turned on once, then turned off.
 - ① See section 2.1.

2.3 INTERFACE MODULE (AIF02C) LED INDICATORS

The LED indicator panel of the AIF02C is shown below. Each of its components are described in the following paragraphs.

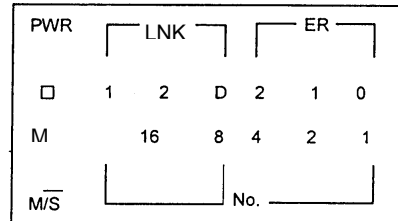

2.3.1 PWR indicator

This LED lights when the power is switched on.

2.3.2 LNK indicators

- (1) LNK-1 : Lights when the I/O link for the I/O Unit-A is operating normally.
- (2) LNK-2 : Lights when the I/O link for the I/O Unit-B is operating normally.
- (3) LNK-D : Lights when the distributed link with the I/O Unit-B is operating normally. (The indicator dims if only a few base units are connected.)

2.3.3 ER indicators

An ER indicator lights if an error occurs on the distributed link.

See the tables on the following page for details.

2.3.4 LED indicators

- (1) When the unit No. (1 to 16) is off (o-on and ×-off)

| M/S | ER2 | ER1 | ER0 | Error | Description | Major cause of error |
|-----|-----|-----|-----|-------------------------------------|------------------------------------------------------------|---------------------------------------------|
| ○ | × | × | ○ | Interface unit peripheral error | The interface unit is abnormal. | Interface unit failure |
| ○ | × | ○ | × | Interface unit RAM parity error | The interface unit is abnormal. | Interface unit failure |
| ○ | ○ | × | × | I/O link error reception | An error has occurred in a unit connected to the I/O link. | Failure in a unit connected to the I/O link |
| ○ | ○ | × | ○ | I/O link framing error | The I/O link communication end signal is abnormal. | - |
| ○ | ○ | ○ | × | I/O link CRC error | I/O link communication data is abnormal. | - |
| ○ | ○ | ○ | ○ | Interface unit watchdog timer error | Communication from the I/O link host has stopped. | - |

(2) When the unit No. (1 to 16) is on (o-on and ×-off)

| M/S | ER2 | ER1 | ER0 | Error | Description | Major cause of error |
|------------|-----|-----|-----|---------------------------------------|-------------------------------------------------------------------------|-------------------------------------------------------------------------------------------------------------------|
| × | × | × | ○ | Basic unit peripheral error | The basic unit is abnormal. | Basic unit failure |
| ○ | × | ○ | × | Basic unit number error | A unit with an invalid unit number has responded to the interface unit. | - |
| × | × | ○ | ○ | Basic unit reception data count error | The number of communication bytes has exceeded four. | Two or more units have the same unit number, or the unit of interest is not provided with a terminating resistor. |
| ×○ (*1) | ○ | × | × | Basic unit framing error | The communication end signal is abnormal. | Two or more units have the same unit number, or the unit of interest is not provided with a terminating resistor. |
| ×○ (*1) | ○ | × | ○ | Basic unit DMI error | The communication waveform has been distorted. | Two or more units have the same unit number, or the unit of interest is not provided with a terminating resistor. |
| ×○ (*1) | ○ | ○ | × | Basic unit CRC error | The communication data is abnormal. | Two or more units have the same unit number, or the unit of interest is not provided with a terminating resistor. |
| × | ○ | ○ | ○ | Basic unit watchdog timer error | Communication with the interface unit has stopped. | - |

NOTE (*1)

If M/S lights, it means that the interface detected the error.

If it does not light, it means that the basic unit detected the error.

2.3.5 M/S̄ indicator

If an error occurs on a distributed link, the M/S indicator indicates whether the error was detected in the interface module or basic error side.

On: The error has been detected on the interface module side.

Off: The error has been detected on the basic unit side.

2.3.6 No. Indicators

If an error occurs on a distributed link, the No. indicators indicate the basic unit No. where the error is detected. The sum of the values for which a lamp lights corresponds to the basic unit No.

Example)

| No. | | | | | Unit No. | O-On x-Off |
|-----|---|---|---|---|----------|---------------|
| 16 | 8 | 4 | 2 | 1 | | |
| x | x | x | x | ○ | 1 | |
| x | x | ○ | x | ○ | 5 | |
| x | ○ | x | ○ | x | 10 | |
| ○ | x | ○ | x | x | 20 | |

2.4 LED INDICATORS ON THE INPUT/OUTPUT MODULES (HAVING 16 OR FEWER INPUT/OUTPUT POINTS)

| | |
|-----------|---|
| A01234567 | F |
| B01234567 | |

| Label | Name | Description |
|--------------------|------------------------|----------------------------------------------------------|
| A0 to 7 B0 to 7 | Input/output indicator | On : The corresponding input or output is on. |
| F | Fuse alarm | On : A fuse incorporated in the output module has blown. |

3

FUSES

The modules listed below have built-in fuses. If a fuse blows, remove the cause, then replace the fuse with a spare.

| Module | Indication | Rating | Fuse specification |
|----------------------------------------|-------------|--------|---------------------|
| Interface module AIF01A | PWR is off | 3.2A | A60L-0001-0290#LM32 |
| Interface module AIF01B | PWR is off. | 3.2A | A60L-0001-0290#LM32 |
| Interface module AIF02C | PWR is off. | 3.2A | A60L-0001-0290#LM32 |
| Output module with 8 DC points AOD08C | F is on. | 5A | A60L-0001-0260#5R00 |
| Output module with 8 DC points AOD08D | F is on. | 5A | A60L-0001-0260#5R00 |
| Output module with 5 AC points AOA05E | F is on. | 3.15A | A60L-0001-0276#3.15 |
| Output module with 8 AC points AOA08E | F is on. | 3.15A | A60L-0001-0276#3.15 |
| Output module with 12 AC points AOA12F | F is on. | 3.15A | A60L-0001-0276#3.15 |

The fuses are on the PC boards in the modules.

4

REMOVING PC BOARDS

4.1

HOW TO REMOVE TERMINAL BOARD-TYPE I/O MODULE PC BOARDS

- ① Remove the terminal board. (Refer to I-4.5)
- ② Pull the LED cap in the direction of the arrow to remove it.

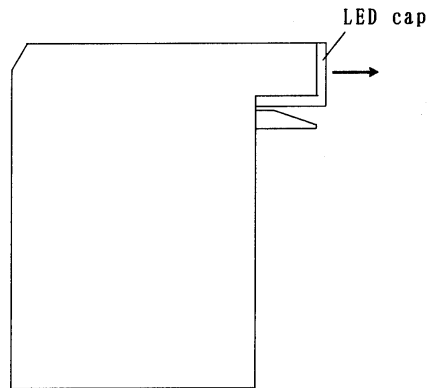

- ③ While pressing connector ① in the direction of the arrow, raise the tabs (two) on the module case with a flat-blade screwdriver.

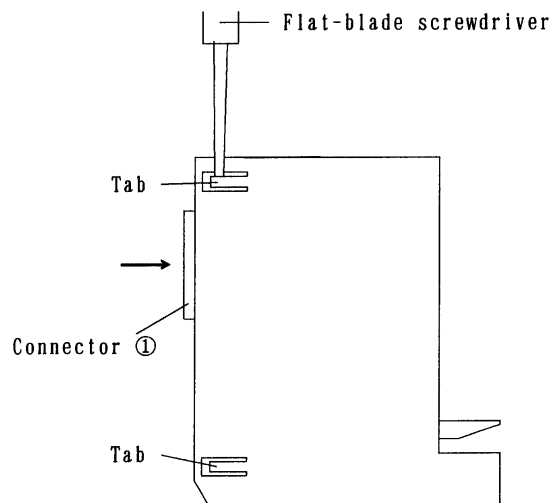

- ④ Put the tip of a flat-blade screwdriver into the gap between the module case and terminal board connector, as shown below. While pressing the screwdriver in the direction of arrow A, push connector ① in the direction of arrow B, and the PC board will come out.

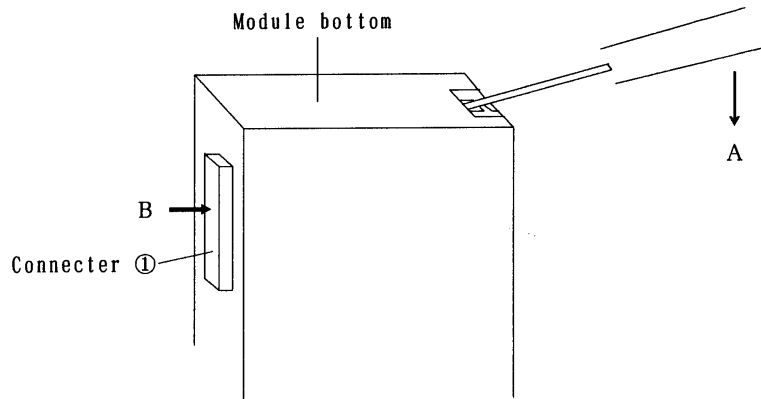

4.2 HOW TO REMOVE INTERFACE AND CONNECTOR-TYPE I/O MODULE PC BOARDS

- ① While pulling the cover in the direction of the arrow, press points ① and ② (on each side) with a flat-blade screwdriver to remove the cover.

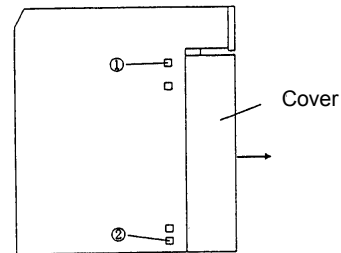

- ② Pull the LED cap in the direction of the arrow to remove it.

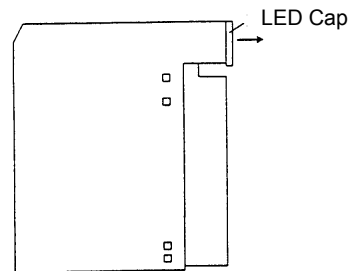

- ③ While pressing connector ① in the direction of the arrow, raise the tabs (two for a connector type I/O module and 4 for an interface module) with a flat-screwdriver, then push connector ① in the direction of the arrow, and the PC board will come out.

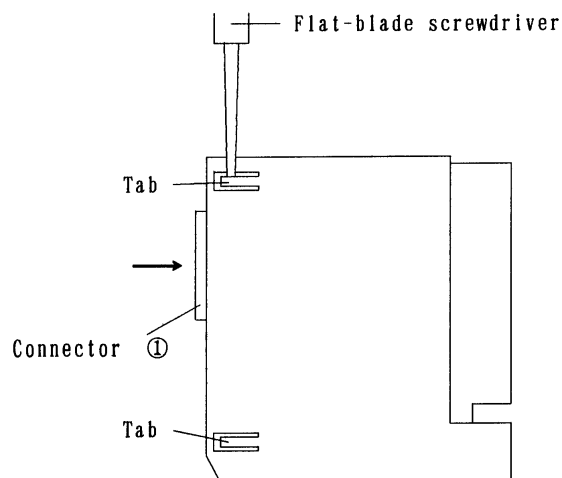

12

12-BIT ANALOG OUTPUT MODULE (ADA02A) 65

A

ALLOCATION OF I/O POINTS 5

ANALOG INPUT MODULE (AAD04A) 61

ANALOG OUTPUT MODULE 65

B

BLOCK DIAGRAM 137

C

Comparison function 72

COMPLETE CONNECTION OF TEMPERATURE
INPUT MODULE 107

Configuration of mode A 93

CONFIGURATION 4

Connecting FANUC I/O Link dummy units in series 129

CONNECTING INPUT POWER SOURCE 15

CONNECTING WITH ANALOG INPUT MODULE 64

CONNECTING WITH I/O MODULES 25

Connection between the Analog Output Module and
Load 69

Connection diagram 86

CONNECTION DIAGRAMS 128

CONNECTION OF OPTICAL I/O LINK 121

Connection to Analog Output Module 67

CONNECTION WITH POWER MAGNETICS
CABINET 90

CONNECTION WITH PULSE GENERATOR 88

CONNECTION 14

Connection 22

Connector signal list 87

Connector signal lists 108

CORRESPONDENCE BETWEEN I/O SIGNALS
AND ADDRESSES IN A MODULE 29CORRESPONDENCE BETWEEN INPUT SIGNALS
AND ADDRESSES IN A MODULE 62Correspondence between Output Signals and Addresses
in a Module 66Correspondence between Output Signals and Addresses
in the Module 68

Counter presetting and counting 94

D

DC input signals (ME and CSP) 92

DESIGNING CONDITION FOR A CABINET 10

Details of input signals (temperature module → PMC) 104

Details of output signals (PMC → temperature module) 102

Details of PMC interface signals 83

DIGITAL INPUT / OUTPUT MODULES 27

E

ENVIRONMENTAL CONDITIONS 9

ER indicators 146

External contact input 76

External contact output 76

EXTERNAL DIMENSION OF OPTICAL I/O LINK 120

EXTERNAL DIMENSIONS 126

External view of optical fiber cable 122

F

FANUC I/O LINK 3

FOURTEEN-BIT ANALOG OUTPUT MODULE
(ADA02B) 68

FUSES 149

G

GENERAL CONNECTION DIAGRAM 14

Grounding 129

GROUNDING 16

H

HIGH SPEED COUNTER MODULE 70

HOW TO REMOVE INTERFACE AND
CONNECTOR-TYPE I/O MODULE PC BOARDS 152HOW TO REMOVE TERMINAL BOARD-TYPE I/O
MODULE PC BOARDS 150

| | | | |
|-------------------------------------------------------------------------------------|-----|------------------------------------------|-----|
| I | | Miscellaneous information | 98 |
| I/O LINK DUMMY UNIT | 126 | Mode A | 79 |
| I/O SIGNALS CONVENTIONS | 91 | Mode B | 81 |
| I/O UNIT CONFIGURATION | 8 | MOUNTING AND DISMOUNTING MODULES | 13 |
| I/O UNIT-A CONFIGURATION | 136 | N | |
| INDICATION | 140 | No. Indicators | 148 |
| Installation Category (Overvoltage Category) | 132 | Notice of optical fiber cable handling | 123 |
| INSTALLATION CONDITIONS OF OPTICAL I/O LINK ADAPTER | 122 | O | |
| INSTALLATION CONDITIONS | 127 | Optical fiber cable clamping method | 124 |
| INSTALLATION ENVIRONMENT | 132 | OPTICAL FIBER CABLE | 122 |
| INSTALLATION | 9 | OPTICAL I/O LINK ADAPTER | 119 |
| INTERFACE MODULE (AIF01A) LEDES | 140 | OUTER DIMENSION OF I/O Unit | 11 |
| INTERFACE MODULE (AIF01A, AIF01B) | 18 | OUTLINE OF HIGH SPEED COUNTER MODULE | 70 |
| INTERFACE MODULE (AIF01B) LEDES | 144 | Overview | 21 |
| INTERFACE MODULE (AIF02C) CONNECTION | 21 | OVERVIEW | 99 |
| INTERFACE MODULE (AIF02C) LED INDICATORS | 146 | OVERVIEW | 135 |
| K | | OVERVIEW | 126 |
| K3X cable | 130 | P | |
| L | | PMC I/O area | 101 |
| LED INDICATORS ON THE INPUT/OUTPUT MODULES (HAVING 16 OR FEWER INPUT/OUTPUT POINTS) | 148 | PMC INTERFACE | 101 |
| LED INDICATORS | 127 | PMC INTERFACE | 79 |
| LED indicators | 146 | Pollution Degree | 132 |
| LED Indicators | 77 | POWER REQUIREMENTS | 127 |
| LIST OF MODULES | 27 | POWER SOURCE OF OPTICAL I/O LINK ADAPTER | 121 |
| LIST OF UNITS | 138 | Pulse counter | 72 |
| LNK indicators | 146 | Pulse Interface | 74 |
| M | | PWR indicator | 146 |
| M/S indicator | 147 | R | |
| Marker processing | 76 | Reading data | 97 |
| Maximum transmission distance by optical fiber cable | 125 | Relay using an optical fiber adapter | 125 |
| MEASUREMENT EXAMPLES | 111 | REMOVING PC BOARDS | 150 |
| Measurement mode | 102 | REQUIRED CURRENT | 17 |

S

| | |
|-------------------------------------------------|-----|
| SAFETY FOR USING AC | 131 |
| Setting data | 95 |
| Setting with the DIP switch | 24 |
| Solid state relay output signals (OUT0 to OUT7) | 91 |
| SPECIFICATION FOR EACH MODULE | 30 |
| Specification | 65 |
| Specification | 68 |
| SPECIFICATIONS FOR ANALOG INPUT MODULE61 | |
| SPECIFICATIONS OF HIGH SPEED COUNTER MODULE | 72 |
| SUPPLEMENT | 93 |
| SYSTEM CONFIGURATION | 135 |

T

| | |
|--------------------------------------------------|-----|
| Temperature input module connection diagram | 107 |
| TEMPERATURE INPUT MODULE SPECIFICATION | 100 |
| TEMPERATURE INPUT MODULE | 99 |
| TERMINAL BOARD UNIT DIMENSIONS | 118 |
| Terminal board unit connection diagram | 109 |
| TIMING CHARTS | 110 |
| TOTAL CONNECTION OF HIGH SPEED COUNTER MODULE | 86 |

U

| | |
|---------------------------------|----|
| Use of phase A and B pulses | 88 |
| Use of positive/negative pulses | 89 |

W

| | |
|-------------------------------------------------------------|-----|
| WEIGHT OF OPTICAL I/O LINK | 120 |
| WEIGHT | 127 |
| When not connecting FANUC I/O Link dummy units in series | 128 |

Revision Record

FANUC I/O Unit-MODEL A CONNECTION·MAINTENANCE MANUAL (B-61813E/03)

| Edition | Date | Contents | Edition | Date | Contents | Contents |
|----------------|-------------|---------------------------------------------------------------------------------------------------------------------------------------------------------------------------------------------------------------------------------------------------------------------------------------------------------------------------------------------------------------------------------|----------------|-------------|-----------------|-----------------|
| 03 | Feb., 2000 | <ul style="list-style-type: none"> • Addition of "I/O Link dummy unit" • Addition of Inter face module (AIF02C) • Addition of Input module (AID16K, AID16L) • Addition of High-resolution type analog output module (ADA02B) • Addition of "Temperature input module" • Modification of "High speed counter module" | | | | |
| 02 | Apr., 1992 | <ul style="list-style-type: none"> • Addition of high speed counter module • Addition of Optical fiber Cable | | | | |
| 01 | Dec., 1990 | _____ | | | | |

| | |
|---------------------------------------------------------------------------------------------------------------------------------------------------------------------------------------------------------------------------------------------------------------------------------------------|----------------------------------------------------------------------------------------------------------------------------------------------------------------------------------------------------------------------------------------------------------------------------------------|
| <p align="center">EUROPEAN HEADQUARTERS – GRAND-DUCHÉ DE LUXEMBOURG GE Fanuc Automation Europe S.A. Zone Industrielle L-6468 Echternach ☎ (+352) 727979 - 1 ☎ (+352) 727979 - 214</p> | <p align="center">BELGIUM / NETHERLANDS GE Fanuc Automation Europe S.A. - Netherlands Branch - Postbus 7230 - NL-4800 GE Breda Minervum 1603A - NL-4817 ZL Breda ☎ (+31) 76-5783 201 (CNC) ☎ (+31) 76-5783 212 (PLC) ☎ (+31) 76-5870 181</p> |
| <p align="center">CZECH REPUBLIC GE Fanuc Automation CR s.r.o. U studanky 3 CZ-170 00 Praha 7 ☎ (+420) 2 333 72 502 (CNC) ☎ (+420) 2 333 72 503 (PLC) ☎ (+420) 2 333 70 821</p> | <p align="center">FRANCE GE Fanuc Automation France S.A. 39, rue du Saule Trapu, BP 219 F-91882 Massy Cedex ☎ (+33) 1 69 75 86 39 (CNC) ☎ (+33) 1 69 75 86 20 (PLC) ☎ (+33) 1 69 75 86 49</p> |
| <p align="center">GERMANY GE Fanuc Automation GmbH Bernhäuser Straße 22 D-73765 Neuhausen a.d.F ☎ (+49) 7158 187 400 ☎ (+49) 7158 187 455 (CNC) ☎ (+49) 7158 187 466 (PLC)</p> | <p align="center">GERMANY GE Fanuc Eberle Automation GmbH Ernst-Weyden-Str. 7 D-51105 Köln (Cologne) ☎ (+49) 221-83904-53 ☎ (+49) 221-83904-55</p> |
| <p align="center">GERMANY GE Fanuc Automation GmbH Elberfelderstr. 45 D-40724 Hilden ☎ (+49) 2103 247410 (Laser/CNC) ☎ (+49) 2103 247420 (Laser/CNC)</p> | <p align="center">GERMANY GE Fanuc Automation GmbH Obere Hauptstr. 72 D-09244 Lichtenau ☎ (+49) 37208 695 20(CNC) ☎ (+49) 37208 695 30 (PLC) ☎ (+49) 37208 695 55</p> |
| <p align="center">GERMANY GE Fanuc Automation Deutschland GmbH Bensheimer Str. 61 D-65428 Rüsselsheim ☎ (+49) 6142 357600 ☎ (+49) 6142 357611</p> | <p align="center">GERMANY GE Fanuc Eberle Automation GmbH Südwestpark 48 D-90449 Nürnberg ☎ (+49) 911 9672 100 (PLC) ☎ (+49) 911 9672 200 (PLC)</p> |
| <p align="center">GERMANY GE Fanuc Eberle Automation GmbH Reichenbergerstr. 6 D-33605 Bielefeld ☎ (+49) 521 92445 0 (PLC) ☎ (+49) 521 92445 30 (PLC)</p> | <p align="center">SWEDEN GE Fanuc Automation Nordic AB Hammarbacken 4 S-19149 Sollentuna ☎ (+46) 8 444 5520 ☎ (+46) 8 444 5521</p> |
| <p align="center">ITALY GE Fanuc Automation Italia S.r.l. Piazza Tirana 24/4B I-20147 Milano ☎ (+39) 02 417 176 (CNC) ☎ (+39) 02 419 669 (CNC)</p> | <p align="center">ITALY GE Power Controls Italia S.p.a Via Tortona 27 I-20144 Milano ☎ (+39) 02 4242 280 (PLC) ☎ (+39) 02 4242 511 (PLC)</p> |
| <p align="center">SPAIN GE Fanuc Automation España S.A. Polígono Industrial Olaso Calle Olaso, 57 - Locales 10 y 11 E-20870 Elgoibar ☎ (+34) 943 74 82 90 (CNC) ☎ (+34) 943 74 44 21 (CNC)</p> | <p align="center">SPAIN GE Power Controls Ibérica S.L. Calle Marqués de Comillas, 1 E-08225 Terrassa (Barcelona) ☎ (+34) 93 736 58 28 (PLC) ☎ (+34) 93 788 24 03 (PLC)</p> |
| <p align="center">SWITZERLAND GE Fanuc Automation Filiale Suisse/Niederlassung Schweiz Erlenstrasse 35a CH-2555 Brugg b. Biel ☎ (+41) 32 366 63 63 (CNC) ☎ (+41) 32 366 63 33 (PLC) ☎ (+41) 32 366 63 64 (CNC) ☎ (+41) 32 366 63 34 (PLC)</p> | <p align="center">UNITED KINGDOM GE Fanuc Automation (UK) Ltd. Unit 1 - Mill Square Featherstone Road Wolverton Mill South Milton Keynes MK12 5BZ ☎ (+44) 1908 84 4000 ☎ (+44) 1908 84 4001</p> |

- No part of this manual may be reproduced in any form.
- All specifications and designs are subject to change without prior notice.

The export of this product is subject to the authorization of the government of the country from where the product is exported.

In this manual we have tried as much as possible to describe all the various matters.

However, we cannot describe all the matters which must not be done, or which cannot be done, because there are so many possibilities.

Therefore, matters which are not especially described as possible in this manual should be regarded as “impossible”.