

S245B

Safety Valve

High Performance Valve for Compressed Air

Product Specification Sheet

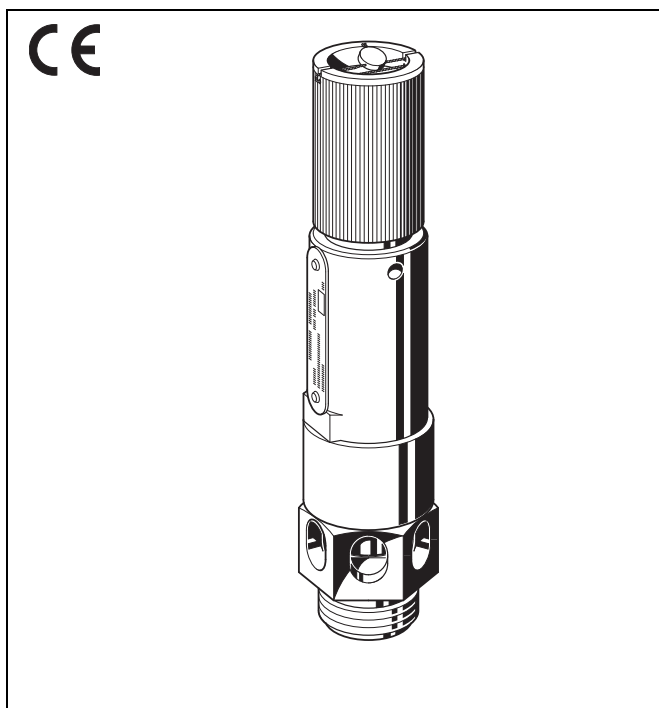

Application

Safety valves of this type are directly loaded high performance safety valves with lifting device. They protect pressurized compressed air vessels (cylinders, tanks) against excessive pressure.

Safety valves of this type are used for compressors and other industrial purposes.

Special Features

- Sturdy metal construction
- Shakeproof lifting mechanism admitting no additional load
- Approved by VdTÜV for pressure range from 0.5 - 30.0 bar
- Approved by ASME (American Society of Mechanical Engineers) for pressure range 2.8 - 30.0 bar (41 - 435 PSI)
- Certified to Pressure Equipment Directive 97/23/EC, Reference No. CE 0035
- Set pressure adjustment at factory
- Set pressure settings possible between 0.5 and 30 bar in steps of 0.1 bar
- Light weight

Range of Application

Compressed air.

Non-toxic, non-corrosive, and non-inflammable gases which may be discharged to atmosphere.

Not suitable for oxygen and steam.

Construction

The safety valve comprises:

- Housing
- Spring bonnet
- Valve cone
- Spring

Materials

- Brass housing
- Bonnet of brass (sizes 1/2" to 1")
- Bonnet of cast iron (sizes 1 1/4" to 2"), powder coated
- Valve cone of brass
- Spring of stainless steel or spring steel
- Disc seal of Viton

Technical Data

Max. operating temperature	180 °C ASME 260 °C TÜV / CE
Approval No.	TÜV · SV · 15* - 340 D ₀ D/G 0.73 · p P = set pressure D ₀ = nozzle diameter
ASME approval reference	30.492
Discharge rate	TÜV α _w = 0.73 ASME K _d = 0.863
Connection size	G 1/2" - G 2"

* valid Approval No.

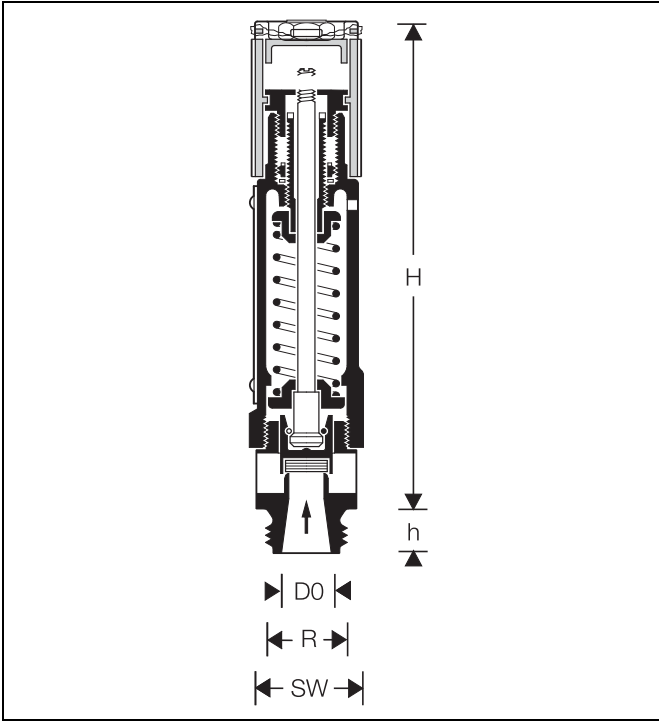

Method of Operation

Safety valves are direct-acting. The disc seal is pushed up by the pressure from the system against a spring which is holding the valve closed. If the opening force exceeds the force exerted by the spring, the valve disc is lifted off the valve seat and the valve discharges the medium. In accordance with the requirements of the standard, the full discharge capacity of the valve will be achieved when the system pressure climbs to no more than 10 % above the set pressure of the valve. Full shutoff must be achieved if the system pressure falls below 90 % of the nominal set pressure value.

Options

S245B- ... ZA* ... = Safety valve, set pressure 1.0 -12.0 bar

S245B- ... ZB* ... = Safety valve,
set pressure < 1.0 bar or > 12.0 bar

Connection size | Set pressure

Ordering Example

S245B-3/4ZA* 5.8 = Safety valve (soft seat version), size 3/4", set pressure 5.8 bar

S245B-1ZB* 0.8 = Safety valve (soft seat version), size 1", set pressure 0.8 bar

Connection size	R	1/2"	3/4"	1"	1 1/4"	1 1/2"	2"
Weight	(kg)	0.4	0.6	0.9	1.7	3.0	8.0
Dimensions	(mm)	10	15	20	25	32	40
	Doh	12	15	16	18	20	22
	H	138	153	185	231	293	367
	SW	27	36	41	50	60	80

Corrective Factor

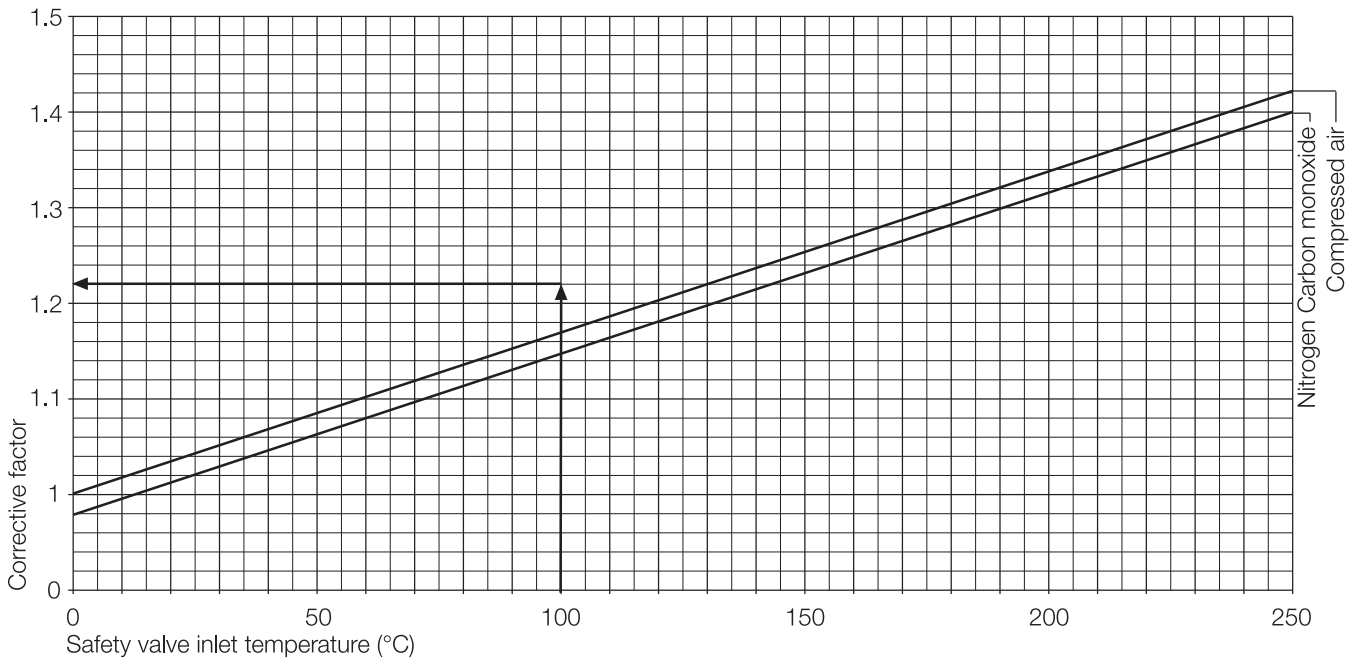

Installation Example

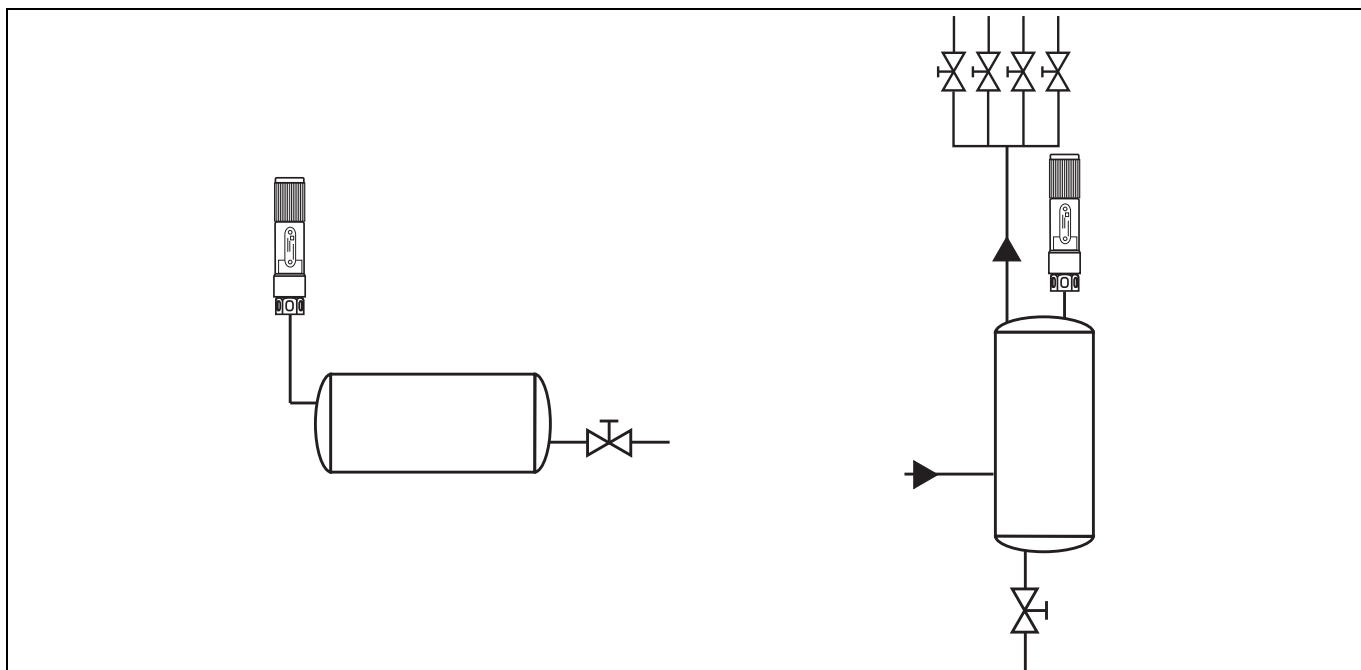

Installation Guidelines

- Safety valves for pressurised air should ideally be positioned vertically, facing upwards in the pipeline or on a pressure vessel. Other installation positions on request.
- Connections through all pipe, fittings and non-reclosing pressure relief devices (if installed) between a pressure vessel and its safety valve shall have at least the area of the safety valve inlet.
- The characteristics of the upstream system shall be such that the pressure drop will not reduce the relieving capacity below that required or adversely affect the proper operation of the safety valve.
- The opening in the vessel wall shall be designed to provide unobstructed flow between the vessel and its safety valve.
- There shall be no intervening stop valves between the vessel and its safety valves.

Typical Applications

Safety valves are fitted where there is a risk of excess or extreme pressures which may injure people or damage equipment.

The following are some typical applications:

- Air supplies to a factory
- Portable compressor units
- Paint spray units
- Pressure tanks

Inspection

A set pressure function test should be carried out at least once per year. The detailed test procedure is determined by the user.

Discharge capacity for compressed air (TÜV) Type S245B [Approval reference TÜV · SV · 15 · 340 · D₀ · D/G · aw · p]

Opening pressure		Amount of air in Nm ³ /h (0 °C, 1.013 bar)						Opening pressure		Amount of air in Nm ³ /h (0 °C, 1.013 bar)					
bar	psi	1/2"	3/4"	1"	1 1/4"	1 1/2"	2"	bar	psi	1/2"	3/4"	1"	1 1/4"	1 1/2"	2"
0.5	7	61	138	245	382	626	978	15.5	225	707	1590	2827	4417	7237	11307
1	15	83	186	331	517	847	1323	16	232	728	1638	2913	4551	7457	11652
1.5	22	104	234	417	651	1067	1667	16.5	239	750	1687	2999	4686	7677	11996
2	29	126	283	503	786	1287	2011	17	247	771	1735	3085	4820	7898	12340
2.5	36	147	331	589	920	1508	2356	17.5	254	793	1784	3171	4955	8118	12684
3	44	169	380	675	1055	1728	2700	18	261	814	1832	3257	5089	8338	13029
3.5	51	190	428	761	1189	1948	3044	18.5	286	836	1881	3343	5224	8559	13373
4	58	212	477	847	1324	2169	3388	19	276	857	1929	3429	5358	8779	13717
4.5	65	233	525	933	1458	2389	3733	19.5	283	879	1977	3515	5493	8999	14062
5	73	255	573	1019	1593	2609	4077	20	290	900	2026	3601	5627	9220	14406
5.5	80	276	622	1105	1727	2830	4421	20.5	297	922	2074	3688	5762	9440	14750
6	87	298	670	1191	1862	3050	4766	21	305	943	2123	3774	5896	9660	15094
6.5	94	319	719	1277	1996	3270	5110	21.5	312	965	2171	3860	6031	9881	15439
7	102	341	767	1364	2131	3491	5454	22	319	986	2219	3946	6165	10101	15783
7.5	109	362	815	1450	2265	3711	4799	22.5	326	1008	2268	4032	6300	10322	16127
8	116	384	864	1536	2400	3931	6143	23	334	1029	2316	4118	6434	10542	16472
8.5	123	405	912	1622	2534	4152	6487	23.5	341	1051	2365	4204	6569	10762	16816
9	131	427	961	1708	2669	4372	6831	24	348	1073	2413	4290	6703	10983	17160
9.5	138	448	1009	1794	2803	4592	7176	24.5	355	1094	2462	4376	6838	11203	17505
10	145	470	1058	1880	2938	4813	7520	25	363	1116	2510	4462	6972	11423	17849
10.5	152	492	1106	1966	3072	5033	7864	25.5	37	1137	2558	4548	7107	11644	18193
11	160	513	1154	2052	3206	5254	8209	26	377	1159	2607	4634	7241	11864	18537
11.5	167	535	1203	2138	3341	5474	8553	26.5	384	1180	2655	4720	7376	12084	18882
12	174	556	1251	2224	3475	5694	8897	27	392	1202	2704	4807	7510	12305	19226
12.5	181	578	1300	2310	3610	5915	9241	27.5	399	1223	2752	4893	7645	12525	19570
13	189	599	1348	2396	3744	6135	9586	28	406	1245	2800	4979	7779	12745	19915
13.5	196	621	1396	2483	3879	6355	9930	28.5	413	1266	2849	5065	7914	12966	20259
14	203	642	1445	2569	4013	6576	10274	29	421	1288	2897	5151	8048	13186	20603
14.5	210	664	1493	2655	4148	6796	10619	29.5	428	1309	2946	4237	8183	13406	20947
15	218	685	1542	2741	4282	7016	10963	30	435	1331	2994	5323	8317	13627	21292

Discharge capacity for compressed air (ASME) Type S245B [Approval reference ASME 30,492]

Opening pressure		Discharge capacity in SCFM* (60 °F, 14.5 PSI)						Opening pressure		Discharge capacity in SCFM* (60 °F, 14.5 PSI)					
bar	psi	1/2"	3/4"	1"	1 1/4"	1 1/2"	2"	bar	psi	1/2"	3/4"	1"	1 1/4"	1 1/2"	2"
2.8	41	115	258	458	716	1173	1832	16.5	239	538	1210	2150	3360	5505	8601
3.0	44	121	272	483	754	1236	1931	17	247	553	1244	2212	3456	5663	8848
3.5	51	136	306	545	851	1394	2178	17.5	254	568	1279	2274	3553	5821	9095
4.0	58	152	341	606	947	1552	2425	18	261	584	1314	2336	3649	5979	9342
4.5	65	167	376	668	1044	1710	2672	18.5	268	599	1348	2397	3746	6137	9589
5.0	73	182	411	730	1140	1868	2919	19	276	615	1383	2459	3842	6295	9836
5.5	80	198	445	792	1237	2027	3166	19.5	283	630	1418	2521	3939	6453	10083
6.0	87	213	480	853	1333	2185	3413	20	290	646	1453	2583	4035	6611	10330
6.5	94	229	515	915	1430	2343	3661	20.5	297	661	1487	2644	4132	6769	10577
7.0	102	244	549	977	1526	2501	3908	21	305	677	1522	2706	4228	6928	10824
7.5	109	260	584	1039	1623	2659	4155	21.5	312	692	1557	2768	4325	7086	11071
8.0	116	275	616	1100	1719	2817	4402	22	319	707	1592	2830	4421	7244	11318
8.5	123	291	654	1162	1816	2975	4649	22.5	326	723	1626	2891	4518	7402	11565
9.0	131	306	688	1224	1912	3133	4896	23	334	738	1661	2953	4614	7560	11812
9.5	138	321	723	1286	2009	3291	5143	23.5	341	754	1696	3015	4711	7718	12059
10.0	145	337	758	1347	2105	3449	5390	24	348	769	1731	3077	4807	7876	12306
10.5	152	352	793	1409	2202	3608	5637	24.5	355	785	1765	3138	4904	8034	12554
11.0	160	368	827	1471	2298	3766	5884	25	363	800	1800	3200	5000	8192	12801
11.5	167	383	862	1533	2395	3924	6131	25.5	370	815	1835	3262	5097	8350	13048
12.0	174	399	897	1594	2491	4082	6378	26	377	831	1870	3324	5193	8509	13295
12.5	181	414	932	1656	2588	4240	6625	26.5	384	846	1904	3385	5290	8667	13542
13.0	189	429	966	1718	2684	4398	6872	27	392	862	1939	3447	5386	8825	13789
13.5	196	445	1001	1780	2781	4556	7119	27.5	399	877	1974	3509	5483	8983	14036
14.0	203	460	1036	1841	2877	4714	7366	28	406	893	2009	3571	5579	9141	14283
14.5	210	476	1071	1903	2974	4872	7613	28.5	413	908	2043	3632	5676	9299	14530
15.0	218	491	1105	1965	3070	5030	7860	29	421	924	2078	3694	5772	9457	14777
15.5	225	507	1140	2027	3167	5188	8107	29.5	428	939	2113	3756	5869	9615	15024
16.0	232	522	1175	2089	3263	5347	8354	30	435	954	2147	3818	5965	9773	15271

Certified coefficient of discharge (TÜV)aw = 0.73

Certified coefficient of discharge (ASME)Kd = 0.863 SCFM = standard cubic feet minute

Environmental and Combustion Controls

Honeywell GmbH
 Hardhofweg
 74821 MOSBACH
 GERMANY
 Phone: (49) 6261 810
 Fax: (49) 6261 81309
 www.honeywell.com

Manufactured for and on behalf of the
 Environmental and Combustion Controls Division
 of Honeywell Technologies Sàrl, Z.A. La Pièce 16,
 1180 Rolle, Switzerland by its Authorised Representative Honeywell GmbH

EN0H-1309GE23 R0615
 Subject to change without notice
 © 2015 Honeywell GmbH

