

Models SSR-XW and SSR-XWM

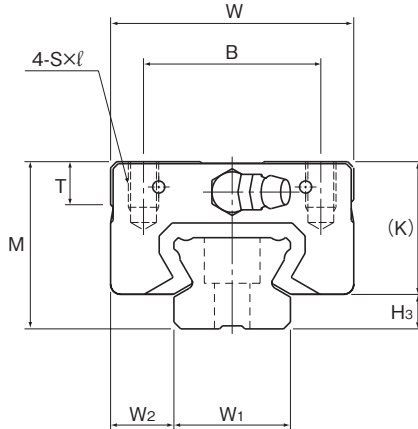

Model No.	Outer dimensions			LM block dimensions													Grease nipple	H ₃
	Height M	Width W	Length L	B	C	S×ℓ	L ₁	T	K	N	E	f ₀	e ₀	D ₀				
SSR 15XWY SSR 15XWMY	24	34	56.9	26	26	M4×7	39.9	6.5	19.5	4.5	5.5	2.7	4.5	3	PB1021B	4.5		
SSR 20XW SSR 20XWM	28	42	66.5	32	32	M5×8	46.6	8.2	22	5.5	12	2.8	5.2	3	B-M6F	6		
SSR 25XWY SSR 25XWMY	33	48	83	35	35	M6×9	59.8	8.4	26.2	6	12	3.3	7	3	B-M6F	6.8		
SSR 30XW SSR 30XWM	42	60	97	40	40	M8×12	70.7	11.3	32.5	8	12	4.5	7.6	4	B-M6F	9.5		
SSR 35XW	48	70	110.9	50	50	M8×12	80.5	13	36.5	8.5	12	4.7	8.8	4	B-M6F	11.5		

Note) Symbol M indicates that stainless steel is used in the LM block, LM rail and balls. Those models marked with this symbol are therefore highly resistant to corrosion and environment.

Model number coding

SSR25X W 2 UU C1 M +1200L Y P T M -II

Model number	Type of LM block	Contamination protection accessory symbol (*1)	Stainless steel LM block	LM rail length (in mm)	Accuracy symbol (*3)	Stainless steel LM rail	Symbol for No. of rails used on the same plane (*4)
	No. of LM blocks used on the same rail	Radial clearance symbol (*2) Normal (No symbol) Light preload (C1) Medium preload (C0)		Applied to only 15 and 25	Normal grade (No Symbol) High accuracy grade (H)/Precision grade (P) Super precision grade (SP)/Ultra precision grade (UP)	Symbol for LM rail jointed use	

(*1) See contamination protection accessory on A-368. (*2) See A-113. (*3) See A-119. (*4) See A-59.

Note) This model number indicates that a single-rail unit constitutes one set. (i.e., required number of sets when 2 rails are used in parallel is 2 at a minimum.)

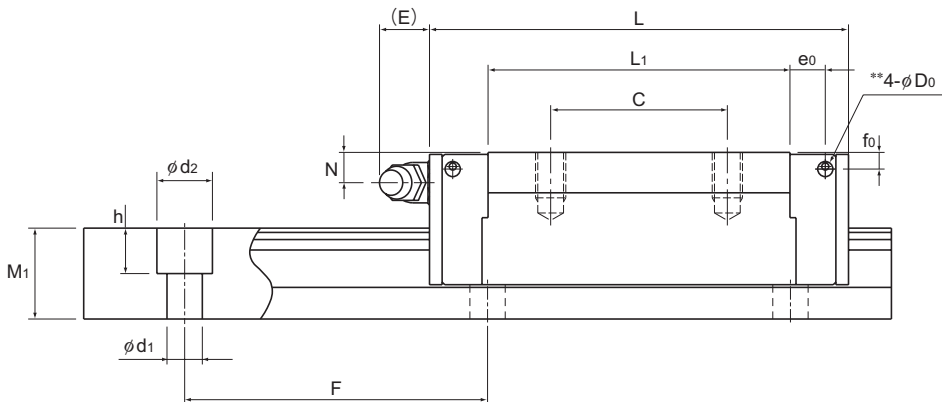

Unit: mm

LM rail dimensions						Basic load rating		Static permissible moment kN·m*					Mass	
Width	Height	Pitch		Length*		C	C ₀	M _a		M _b		M _c	LM block	LM rail
W_1 ± 0.05	W_2	M_1	F	$d_1 \times d_2 \times h$	Max	kN	kN	1 block	Double blocks	1 block	Double blocks	1 block	kg	kg/m
15	9.5	12.5	60	4.5×7.5×5.3	2500 (1240)	14.7	16.5	0.0792	0.44	0.0486	0.274	0.0962	0.15	1.2
20	11	15.5	60	6×9.5×8.5	3000 (1480)	19.6	23.4	0.138	0.723	0.0847	0.448	0.18	0.25	2.1
23	12.5	18	60	7×11×9	3000 (2020)	31.5	36.4	0.258	1.42	0.158	0.884	0.33	0.4	2.7
28	16	23	80	7×11×9	3000 (2520)	46.5	52.7	0.446	2.4	0.274	1.49	0.571	0.8	4.3
34	18	27.5	80	9×14×12	3000	64.6	71.6	0.711	3.72	0.437	2.31	0.936	1.1	6.4

Note1) Pilot holes for side nipples** are not drilled through in order to prevent foreign material from entering the product. THK will mount grease nipples per your request. Therefore, do not use the side nipple pilot holes** for purposes other than mounting a grease nipple.

The maximum length under "Length*" indicates the standard maximum length of an LM rail. (See B-22.)

Static permissible moment*: 1 block: static permissible moment value with 1 LM block

Double blocks: static permissible moment value with 2 blocks closely contacting with each other

Note2) The LM rail mounting hole of SSR15X is drilled for M4 screws as standard (with Y indication). If you order the hole to be drilled for M3 screws (without Y indication), contact THK. When replacing this model with model SR, pay attention to the dimension of the rail mounting hole.