

EURO-BEARINGS LTD

LINEAR BEARINGS & HOUSINGS



www.euro-bearings.com

Tel. 01908 511733

email: sales@euro-bearings.com

GENERAL INFORMATION

Introduction

Ball bushings are anti-friction bearings for linear motion. They offer the familiar advantages of ball bearings. e.g. Long service life, high precision and efficiency.

General Information

NB Ball Bushings are manufactured in Japan by Nippon Bearing Co. which is one of the largest Japanese Ball Bushing manufacturers. All of the shafts, rails and housings shown in this catalogue are manufactured in Germany. All parts are normally on short lead times (less than 7 days).

Construction and Materials

The outer ring of the ball bushing is made from hardened rolling bearing steel. The cylindrical ground and precision formed cage is made from one single part and is held in position by solid steel endplates. This design saves, in many applications, the use of sealed ball bushings. The special features of these extremely robust units are high rigidity, reliability and durability, especially during assembly.

Speed, Lubrication and Friction

The coefficient of friction μ of NB ball Bushings without seals is very low, approximately 0.001 to 0.003. Standard lubrication practices as applied to anti-friction bearings can be used for all ball bushings. Either oil or grease can be used as a lubricant but in most cases grease is preferable. If necessary NB ball bushings can be used without lubrication. Speeds of up to 2 m/s and accelerations of up to 60 m/s² are generally safe.

Mounting

When mounting a standard ball bushing into a housing an H7 fit for the housing bore is generally required. The ball bushing is secured in the housing by retaining rings, fixing screws or adhesive. To achieve pre-load the recommended tolerance for the housing bore can be, in certain cases, JS6 to M6.

Using our housings guarantees best fit and repeatability.

Life expectancy (Load capacity and calculation)

The size of the ball bushing is dictated by its load bearing capacity and its life expectancy. The nominal life span is calculated using this formula:

$$L = \left(\frac{C}{F} \right)^3 \cdot 10^5 m$$

where:
 C = Dynamic load capacity taken from the tables in this catalogue
 F = Dynamic equivalent load
 L = Travel in metres

For more precise calculations some other factors need to be included:

f_H = Shaft hardness (When using our shafts the factor is 1. For other shafts see table below)

f_T = factor for Temperature. An allowance must be made when operating at higher temperatures (i.e >80° C) – see table below

f_L = factor for Life. See chart below if exceeding 10⁵m of travel

Therefore:

$$L = \left(\frac{C}{F} \cdot f_H \cdot f_T \cdot f_L \right)^3 \cdot 10^5 m$$

Factors		1	0.9	0.8	0.7	0.6	0.5	0.4	0.3	0.2	0.1
f_H	Hardness HRC	60	56	55	54	52	49	46	42	33	20
f_T	Temperature	80	100	125	160	200	on demand				
f_L	Travel life	1	1.3	2	3	5	8	15	35	120	1000

STANDARD BALL BUSHINGS

NB Ball Bushings are available as Closed Type NB0.- (with fixed working bore diameter) or Adjustable NB1.- (slotted) type ball bushings.

Cages:

These ball bushings are supplied with a steel cage as standard and held in position with solid steel end plates. Alternatively they can be supplied with a plastic cage using part number NB.0-3..

Seals:

Steel Cage, without seals. Ordering reference: NB.0-0..

Steel Cage, with two seals. Ordering reference: NB.2-0..

(where .. = shaft diameter)

eg. NB00-020 is unsealed with a steel cage; NB02-320 is sealed with a plastic cage



Closed type
NB0.-...

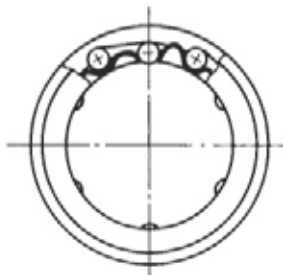

Slotted (adjustable) type
NB1.-...

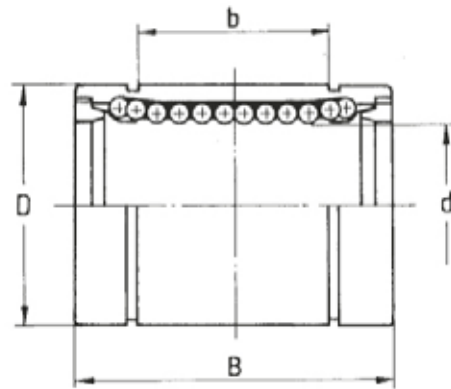
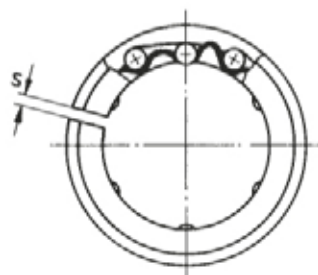

Closed Type	Adjustable Type	d	D	B	b	s	Ball Circuits	Load C (N)	Load C ₀ (N)	Weight (kg)
NB00-005	NB1.-305	5	12	22	12	1	4	210	270	0.01
NB00-008	NB1.-308	8	16	25	14	1	4	280	420	0.02
NB00-010	-	10	19	29	19	1	4	380	560	0.03
NB00-012	NB1.-012	12	22	32	20	1.5	4	570	800	0.04
NB00-016	NB1.-016	16	26	36	22	1.5	4	800	940	0.06
NB00-020	NB1.-020	20	32	45	28	2	5	900	1450	0.10
NB00-025	NB1.-025	25	40	58	40	2	6	1100	1700	0.24
NB00-030	NB1.-030	30	47	68	48	2	6	1700	3000	0.36
NB00-040	NB1.-040	40	62	80	56	3	6	2300	4700	0.77
NB00-050	NB1.-050	50	75	100	72	3	6	4100	8300	1.20
NB00-060	NB1.-060	60	90	125	95	3	6	4800	10200	2.30
NB00-080	NB1.-080	80	120	165	125	3	6	7500	16300	5.20

The load capacity listed in the above table is only valid if the direction of the load is acting directly on the ball race. If the direction of load is acting between two ball races the load rating is multiplied by the factor f.

For sizes 5,8,10,12 & 16, f = 1.41 for size 20 f = 1.46 and for sizes 25 to 80 f = 1.28

SPECIAL BALL BUSHINGS

Special Ball Bushings are identical in construction and materials to the standard ball bushings.

Some of these are dimensionally different to ISO 10285 and the European Standard.

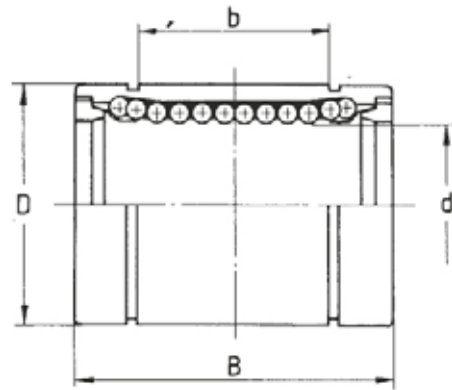
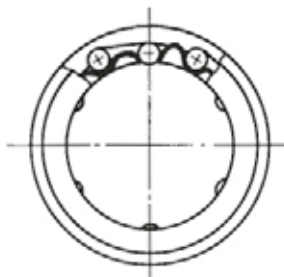

PART (no seals)	PART (2 seals)	d	D	B	b	Ball Circuits	Load C (N)	Load C ₀ (N)	Weight (kg)
NB00-003	NB02-003	3	7	10	-	4	70	100	0.002
NB00-004	NB02-004	4	8	12	-	4	90	130	0.002
SB00-005	SB02-305	5	10	15	8	4	170	210	0.010
NB00-006	NB02-306	6	12	19	11	4	210	270	0.010
SB00-008	SB02-308	8	15	24	15	4	280	400	0.020
SB00-035	SB02-335	35	52	70	45	6	1700	3200	0.400
NB00-100	NB02-100	100	150	175	117	6	14400	35500	8.400
SB00-120	SB02-120	120	180	200	150	8	16700	40800	15.000
SB00-150	SB02-150	150	210	240	160	8	21500	55400	20.200

The load capacity listed in the above table is only valid if the direction of the load is acting directly on the ball race. If the direction of load is acting between two ball races the load rating is multiplied by the factor f. For sizes 3,4,5,6 & 8, f = 1.41 for size 35 & 100 f = 1.28 and for sizes 120 & 150 f = 1.12

OPEN BALL BUSHINGS

NB Open Type Ball Bushings are available with a steel cage as standard which is held in position by solid steel end plates.

Steel Cage, without seals. Ordering reference NB30-0..

Steel Cage, with two seals. Ordering reference NB32-0..

(where ...= shaft diameter)

The bushes can be supplied with a fixing hole and then the bush can be retained in our housings using the fixing screws (supplied with housings)

Fixing screw with nipple:

Shaft sizes 12 to 40: M4

Shaft sizes 50 to 80: M5

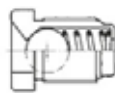

	SW	D	d	h
HS12-40	6	M5	3,5	11
HS50-80	7	M6	4,5	15

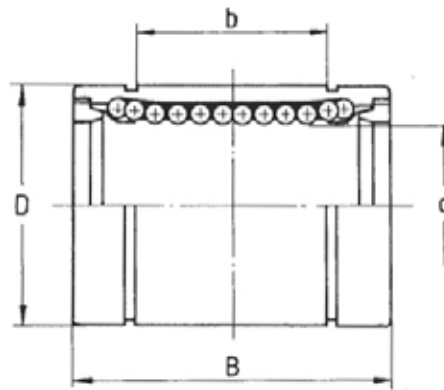
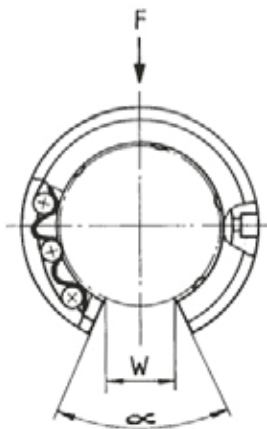

PART (no seals)	PART (2 seals)	d	D	B	b	W	a	Ball Circuits	Load C (N)	Load C ₀ (N)	Weight (kg)
NB30-012	NB32-012	12	22	32	20	7.5	78	3	570	800	0.03
NB30-016	NB32-016	16	26	36	22	10	78	3	800	940	0.05
NB30-020	NB32-020	20	32	45	28	10	60	4	900	1450	0.08
NB30-025	NB32-025	25	40	58	40	12.5	60	5	1100	1700	0.19
NB30-030	NB32-030	30	47	68	48	12.5	50	5	1700	3000	0.30
NB30-040	NB32-040	40	62	80	56	16.8	50	5	2300	4700	0.60
NB30-050	NB32-050	50	75	100	72	21	50	5	4100	8300	0.97
NB30-060	NB32-060	60	90	125	95	27.2	54	5	4800	10200	1.90
NB30-080	NB32-080	80	120	165	125	36.3	54	5	7500	16300	4.38

The load capacity in the above table is only valid if the direction of the load F is acting vertically. If the load is acting from another direction the load rating must be multiplied by the factor f taken from the diagrams below:

12 & 16 mm

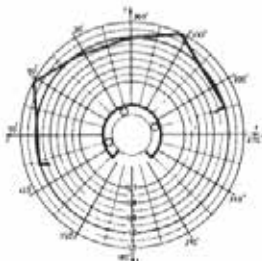

20 mm

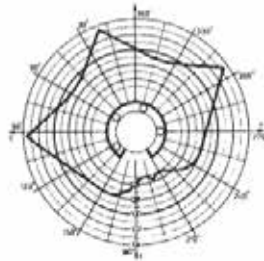

25 to 80 mm

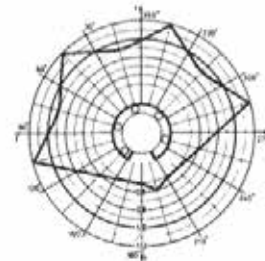

STAINLESS STEEL BALL BUSHINGS

These stainless steel ball bushings have the same boundary dimensions & tolerances as the standard ball bushings (open & closed).

They are used where corrosion resistance is required for example in the food and chemical industries.

Technical specifications of the materials used:

Outer Ring & Balls 1.4125 (SUS440C)
 Steel Cage 1.4301 (SUS304)
 End Plates 1.4021 (SUS420)

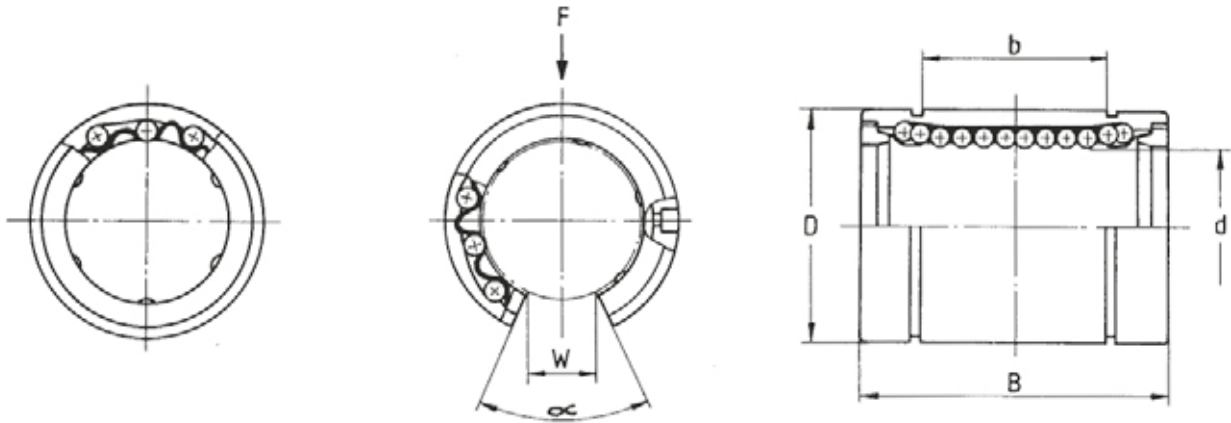

Closed Type	d	D	B	b	Ball circuits	Load C (N)	Load C ₀ (N)	Weight (kg)	Circlip Size
KB50-008	8	16	25	14	4	270	410	0.02	16x1
KB50-012	12	22	32	20	4	520	790	0.05	22x1.2
KB50-016	16	26	36	22	4	590	910	0.06	27x1.2
KB50-020	20	32	45	28	5	880	1400	0.10	33x1.5
KB50-025	25	40	58	40	6	1000	1600	0.24	42x1.75
KB50-030	30	47	68	48	6	1600	2800	0.36	48x1.75
KB50-040	40	62	80	56	6	2200	4100	0.77	62x2
KB50-050	50	75	100	72	6	3900	8100	1.25	75x2.5

KB50's also available for shaft sizes 3, 4, 5, 10 & 60. Please see website for details.

Open Type	d	D	B	b	alpha	W	Ball Circuits	Load C (N)	Load C ₀ (N)	Weight (kg)
KB53-012	12	22	32	20	78	7.5	3	520	790	0.04
KB53-016	16	26	36	22	78	10	3	590	910	0.05
KB53-020	20	32	45	28	60	10	4	880	1400	0.08
KB53-025	25	40	58	40	60	12.5	5	1000	1600	0.20
KB53-030	30	47	68	48	50	12.5	5	1600	2800	0.31
KB53-040	40	62	80	56	50	16.8	5	2200	4100	0.77
KB53-050	50	75	100	72	50	21	5	3900	8100	1.08

ECO BALL BUSHINGS

These high quality ball bushings conform to ISO 10285.

They consist of outer ring and balls made from hardened and ground steel 100Cr6 and the cage is made from poly-acetal.

Integral rubber wiper seals are fitted as standard.

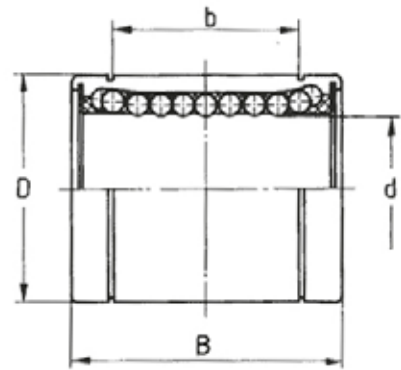
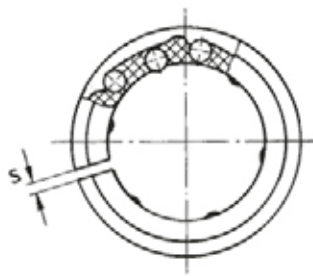
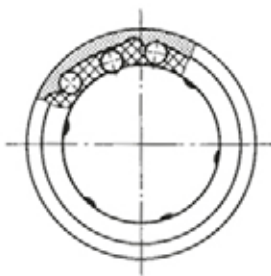

PART	d	D	B	b	s	Circuits	C (N)	C ₀ (N)	Weight (kg)
LME 8 UU	8	16	25	14	1	4	270	410	0.02
LME 12 UU	12	22	32	20	1.5	4	510	780	0.04
LME 16 UU	16	26	36	22	1.5	5	580	890	0.06
LME 20 UU	20	32	45	28	2	5	860	1400	0.09
LME 25 UU	25	40	58	40	2	6	980	1600	0.22
LME 30 UU	30	47	68	48	2	6	1600	2700	0.33
LME 40 UU	40	62	80	56	3	6	2200	4000	0.71
LME 50 UU	50	75	100	72	3	6	3800	7900	1.15
LME 60 UU	60	90	125	95	3	6	4700	10000	2.22

The load capacity listed in the above table is only valid if the direction of the load is acting directly on the ball race. If the direction of load is acting between two ball races the load rating is multiplied by the factor f. For sizes 5,8,12 f = 1.41, for sizes 16 & 20 f = 1.46 and for sizes 25 to 60 f = 1.28

Tel. 01908 511733

www.euro-bearings.com

EURO-BEARINGS LTD

OPEN ECO BALL BUSHINGS

These high quality open type ball bushings conform to ISO 10285.

They consist of outer ring and balls made from hardened and ground steel 100Cr6 and the cage is made from polyacetal.

Integral rubber wiper seals are fitted as standard.

Can be supplied with a fixing hole on request.

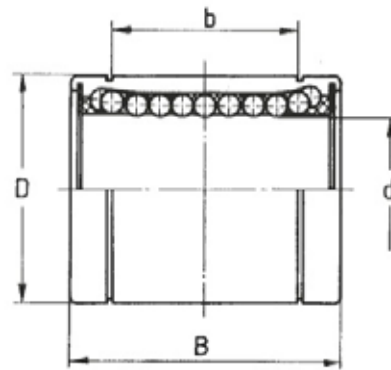
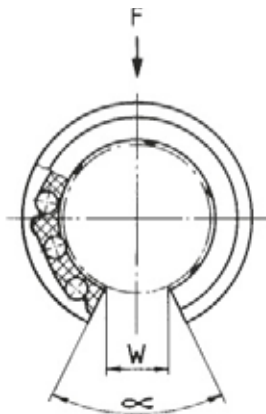

PART	d	D	B	b	W	α	Ball Circuits	Load C (N)	Load C ₀ (N)	Weight (kg)
LMEO-12UU	12	22	32	20	8	78	3	570	800	0.03
LMEO-16UU	16	26	36	22	10	78	4	580	870	0.05
LMEO-20UU	20	32	45	28	10	60	4	860	1400	0.08
LMEO-25UU	25	40	58	40	12.5	60	5	980	1600	0.19
LMEO-30UU	30	47	68	48	12.5	50	5	1600	2700	0.30
LMEO-40UU	40	62	80	56	16.8	50	5	2200	4000	0.60
LMEO-50UU	50	75	100	72	21	50	5	3800	7900	0.97
LMEO-60UU	60	90	125	95	27.2	54	5	4700	10000	1.90

The load capacity in the above table is only valid if the direction of the load F is acting vertically. If the load is acting from another direction the load rating must be multiplied by the factor f taken from the diagrams below:

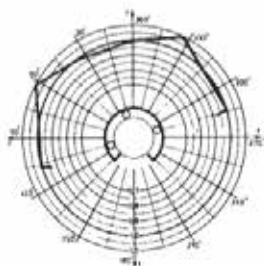

12 & 16 mm

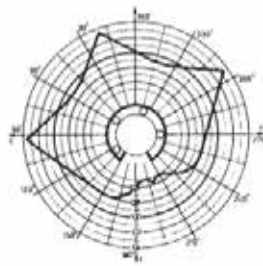

20 mm

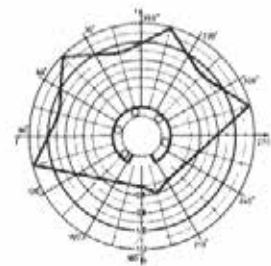

25 to 80 mm

SUPER BALL BUSHINGS

These ball bushings have the same boundary dimensions as the standard ball bushings and are usually interchangeable. The additional ball circuits enable higher load capacities.

Super ball bushings offer the advantage of being able to correct slight errors in alignment. The outer diameter varies along the length making them slightly barrel shaped. It is this shaping that enables it to self align.

The self alignment feature also means that there is no reduction in load capacity due to pressure between the bushing edge and the shaft. The ball tracks are ground and consequently the bushes run smoothly. Speeds of up to 3m/s are possible.

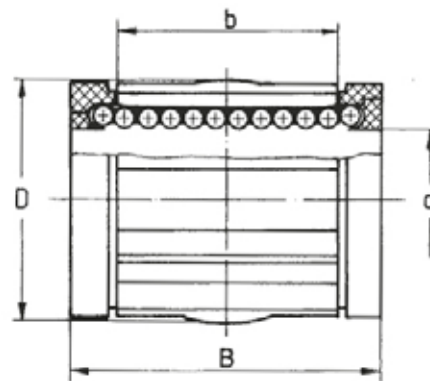
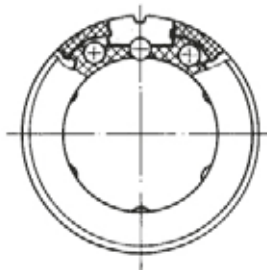

PART (2 seals)	d	D	B	b	Ball Circuits	Load C (N)	Load C ₀ (N)	Weight (kg)	Circlip Size
SK70-208	8	16	25	14.2	4	423	534	0.007	16x1
SK70-210	10	19	29	19	5	750	930	0.014	18x1.2
SK70-212	12	22	32	20	5	1020	1290	0.021	22x1.2
SK70-216	16	26	36	22	5	1250	1550	0.043	27x1.2
SK70-220	20	32	45	28	6	2090	2630	0.058	33x1.5
SK70-225	25	40	58	40	6	3780	4720	0.123	42x1.75
SK70-230	30	47	68	48	6	5470	6810	0.216	48x1.75
SK70-240	40	62	80	56	6	6590	8230	0.333	62x2
SK70-250	50	75	100	72	6	10800	13500	0.618	75x2.5

The load capacity listed in the above table is only valid if the direction of the load is acting directly on the ball race. If the direction of load is acting between two ball races the load rating is multiplied by the factor f.
For size 8 f = 1.41, for sizes 12 & 16 f = 1.46 and for sizes 20 to 40 f = 1.28.

OPEN SUPER BALL BUSHINGS

These ball bushings have the same boundary dimensions as the standard open ball bushings. They offer the same advantage of self alignment as the closed type Super Ball Bushings. An additional ball race in the larger ball bushings increases their carrying capacity slightly. The bushing is provided with a retention hole to secure it against displacement.

The load capacity shown in the table is only valid for load applied vertically. If the load is acting in any other direction, the load capacity must be taken from the diagrams shown below.

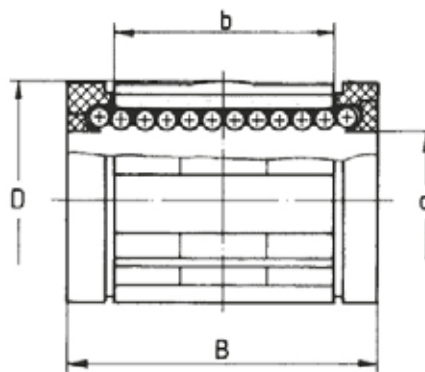
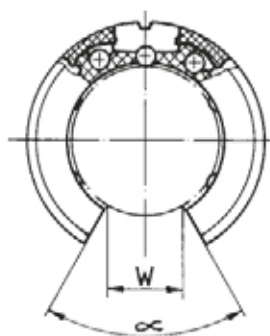

PART (2 seals)	d	D	B	b	w	α	Ball Circuits	Load C (N)	Load C ₀ (N)	Weight (kg)
SK71-212	12	22	32	20	6.5	66	4	1250	1620	0.017
SK71-216	16	26	36	22	9	68	4	1560	1930	0.035
SK71-220	20	32	45	28	9	55	5	2090	2630	0.048
SK71-225	25	40	58	40	11.5	57	5	3070	4720	0.103
SK71-230	30	47	68	48	14	57	5	5470	6810	0.177
SK71-240	40	62	80	56	19.5	56	5	6590	8230	0.275
SK71-250	50	75	100	72	22.5	50	5	10800	13500	0.520

Sizes 12 & 16 mm

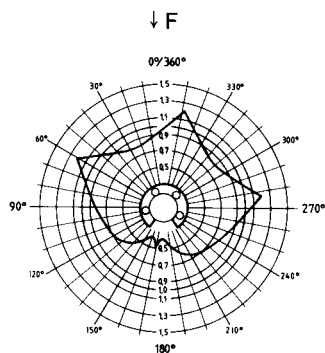

Sizes 20 to 50 mm

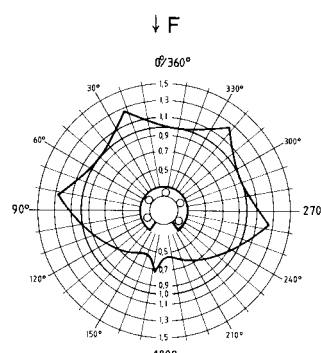

STAINLESS STEEL COMPACT BUSHINGS

These stainless steel compact ball bushings offer a fully re-circulating ball bushing in minimum space.

For housings to suit, see AG27- series. Use with hardened ground shaft and end support series WB58-

The bush is made from 1.4034 (DIN steel number) & the balls from 1.3541.

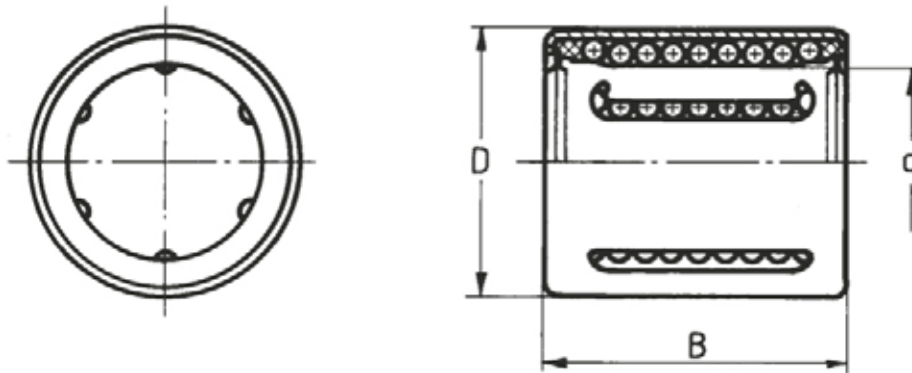

PART (Stainless Steel)	d	D	B	Ball Circuits	Load C (N)	Load C ₀ (N)	Weight (kg)
LBBRn206	6	12	22	4	400	240	0.007
LBBRn208	8	15	24	4	440	280	0.012
LBBRn210	10	17	26	4	500	370	0.015
LBBRn212	12	19	28	5	620	510	0.019
LBBRn214	14	21	28	5	710	530	0.021
LBBRn216	16	24	30	5	800	630	0.028
LBBRn220	20	28	30	6	950	800	0.033
LBBRn225	25	35	40	6	1990	1560	0.066
LBBRn230	30	40	50	7	2900	2700	0.095
LBBRn240	40	52	60	8	5100	4500	0.182
LBBRn250	50	62	70	9	6950	6300	0.252

Tel. 01908 511733

www.euro-bearings.com

EURO-BEARINGS LTD

ECO COMPACT BALL BUSHINGS

These compact ball bushings offer a fully re-circulating ball bushing in minimum space.

For housings to suit, see AG27- series. Use with hardened ground shaft and end support series WB58-

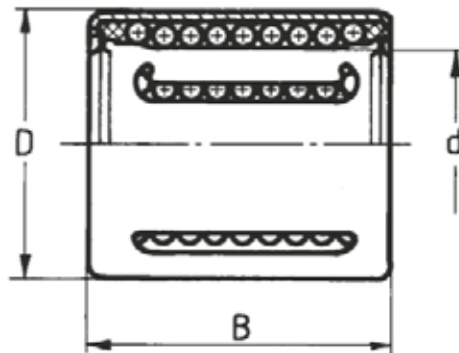
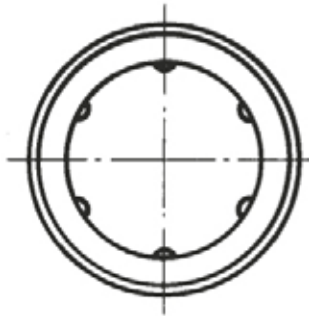

PART	d	D	B	C (N)	C ₀ (N)	Weight (g)
KH0622PP	6	12	22	400	240	7
KH0824PP	8	15	24	440	280	12
KH1026PP	10	17	26	500	370	14.5
KH1228PP	12	19	28	620	510	18.5
KH1428PP	14	21	28	710	530	20.5
KH1630PP	16	24	30	800	630	27.5
KH2030PP	20	28	30	950	800	32.5
KH2540PP	25	35	40	1990	1560	66
KH3050PP	30	40	50	2900	2700	95
KH4060PP	40	52	60	5100	4500	182
KH5070PP	50	62	70	6950	6300	252

ROUND FLANGED BALL BUSHINGS

Flanged ball bushings are a useful means of mounting a ball bushing. The flange and outer ring are made from one billet of steel thereby giving enormous strength to the design. These single ball bushings with round flange are available with seals (FK12-) or without seals (FK10-).

For extra smooth running, these ball bushings are available with a plastic ball retainer. Ordering reference FK12-3..

Certain sizes are also available in stainless steel - enquire using part numbers formulated with a -5 as the first digit of the second group of numbers. For example FK10-520.

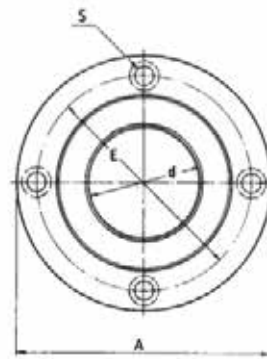
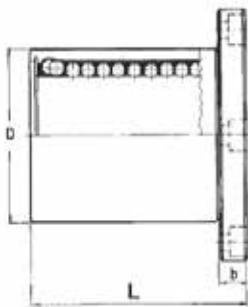

PART (no seals / all steel)	PART (2 seals / plastic cage)	d	D	L	b	A	E	S	Load C (N)	Load C ₀ (N)	Weight (kg)
-	FK12-305	5	12	22	5	28	20	M3	205	265	0.02
FK10-008	FK12-308	8	16	25	5	32	24	M3	280	410	0.04
FK10-012	FK12-312	12	22	32	6	42	32	M4	520	790	0.08
FK10-016	FK12-316	16	26	36	6	46	36	M4	790	1200	0.11
FK10-020	FK12-320	20	32	45	8	54	43	M5	900	1400	0.18
FK10-025	FK12-325	25	40	58	8	62	51	M5	1000	1600	0.34
FK10-030	FK12-330	30	47	68	10	76	62	M6	1600	2800	0.56
FK10-040	FK12-340	40	62	80	13	98	80	M8	2200	4100	1.18
FK10-050	FK12-350	50	75	100	13	112	94	M8	3900	8100	1.70
FK10-060	FK12-360	60	90	125	18	134	112	M10	4700	9800	3.22
FK10-080	FK12-080	80	120	165	18	164	142	M10	7400	16000	6.42

Tel. 01908 511733

www.euro-bearings.com

EURO-BEARINGS LTD

SQUARE FLANGED BALL BUSHINGS

These square flanged ball bushings are made to the European design and have the same characteristics and loadings as our popular range of round flanged ball bushings.

The flange provides a simple but robust mounting system. The ball bushing has 2 integral shaft wiping seals and a plastic cage.

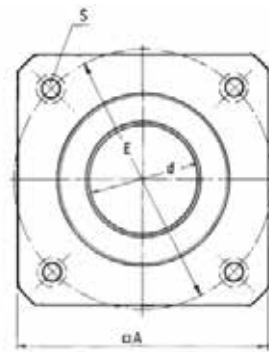
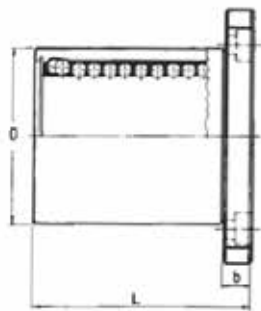

PART (2 seals)	d	D	L	b	A	E	S	Load C (N)	Load C ₀ (N)	Weight (kg)
LMEK08UU	8	16	25	5	25	24	M3	270	410	0.03
LMEK12UU	12	22	32	6	32	32	M4	520	790	0.07
LMEK16UU	16	26	36	6	35	36	M4	590	910	0.09
LMEK20UU	20	32	45	8	42	43	M5	880	1400	0.15
LMEK25UU	25	40	58	8	50	51	M5	1000	1600	0.30
LMEK30UU	30	47	68	10	60	62	M6	1600	2800	0.46
LMEK40UU	40	62	80	13	75	80	M8	2200	4100	0.99

TANDEM ROUND FLANGED BUSHES

The tandem round flanged ball bushings offer all the same benefits as the standard round flanged ball bushings but are longer and consequently have better load capacities.

They are available with seals (FK92-...) or without seals (FK90-...).

For all parts made from steel, the part number is FK90-0.. They are also available with two seals and a polyamide ball retainer - part number FK92-3.. (where .. is the shaft size).

Certain sizes are also available in stainless steel - enquire using part numbers formulated with a -5 as the first digit of the second group of numbers - for example FK90-520.

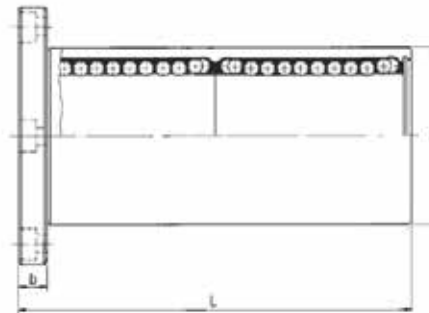
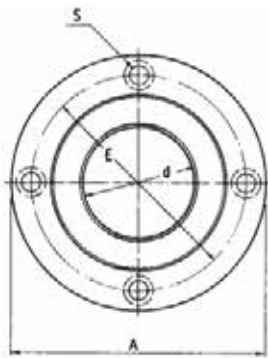

PART NO (2 SEALS)	d	D	L	b	A	E	S	Load C (N)	Load C ₀ (N)	Weight (kg)
FK92-308	8	16	46	5	32	24	M3	440	820	0.06
FK92-312	12	22	61	6	42	32	M4	830	1580	0.10
FK92-316	16	26	68	6	46	36	M4	1250	2400	0.17
FK92-320	20	32	80	8	54	43	M5	1430	2800	0.26
FK92-325	25	40	112	8	62	51	M5	1600	3200	0.52
FK92-330	30	47	123	10	76	62	M6	2550	5600	0.82
FK92-340	40	62	151	13	98	80	M8	3500	8200	1.80
FK92-350	50	75	192	13	112	94	M8	6200	16200	2.80
FK92-360	60	90	209	18	134	112	M10	7600	20000	2.82

TANDEM SQUARE FLANGED BUSHES

These tandem (i.e. double length) square flanged ball bushings are made to the European sizes and have the same characteristics and loadings as our popular range of round flanged ball bushings.

The flange provides a simple but robust mounting system. The ball bushing has 2 integral shaft wiping seals and a polyamide ball retainer.

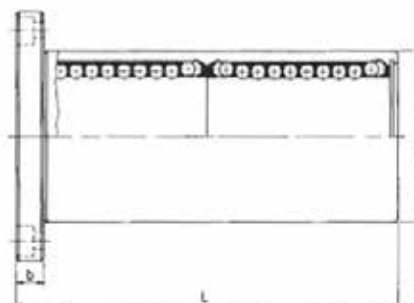
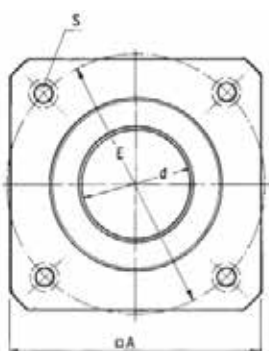

PART (2 seals)	d	D	L	b	A	E	S	Load C (N)	Load C ₀ (N)	Weight (kg)
LMTK08UU	8	16	46	5	25	24	M3	430	780	0.05
LMTK12UU	12	22	61	6	32	32	M4	655	1200	0.08
LMTK16UU	16	26	68	6	35	36	M4	1230	2350	0.16
LMTK20UU	20	32	80	8	42	43	M5	1400	2750	0.23
LMTK25UU	25	40	112	8	50	51	M5	1560	3140	0.47
LMTK30UU	30	47	123	10	60	62	M6	2490	5490	0.57
LMTK40UU	40	62	151	13	75	80	M8	3430	8040	1.38

TANDEM CENTRE ROUND FLANGED BUSH

Tandem Centre Flanged Ball Bushings are specially designed for applications where the shaft is perpendicular to the supporting surface of the bush. The ball bushing can be bolted on through the flanged and therefore there is no need for a housing.

These ball bushings are available with two seals and a polyamide ball retainer, which is secured in the bush through solid end plates. Ordering reference number TF02-3..

The ordering reference number for the unsealed bushing is TF00-...

The Tandem Centre Flanged Ball Bushings are also available with all parts manufactured from steel (unsealed). Ordering reference number TF00-0..

If required they are available with all parts manufactured from stainless steel. Ordering reference number TF00-5..

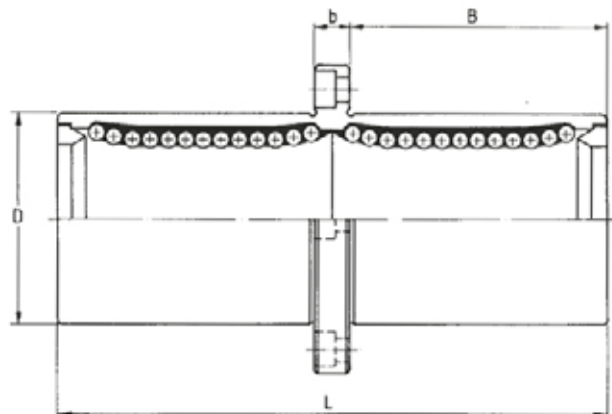
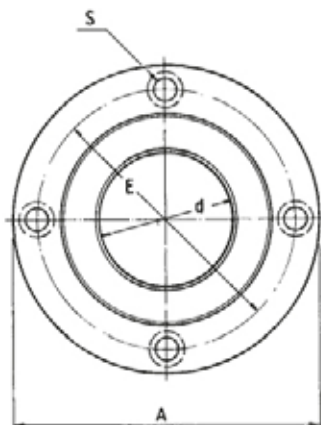

PART (No Seals)	PART (2 Seals)	d	D	L	b	B	A	E	S	Load C (N)	Load C ₀ (N)	Weight (kg)
TF00-008	TF02-308	8	16	46	5	20.5	32	24	M3	430	820	0.06
TF00-012	TF02-312	12	22	61	6	27.5	42	32	M4	830	1580	0.08
TF00-016	TF02-316	16	26	68	6	31	46	36	M4	940	1820	0.10
TF00-020	TF02-320	20	32	80	8	36	54	43	M5	1400	2800	0.26
TF00-025	TF02-325	25	40	112	8	52	62	51	M5	1600	3200	0.54
TF00-030	TF02-330	30	47	123	10	56.5	76	62	M6	2550	5600	0.82
TF00-040	TF02-340	40	62	151	13	69	98	80	M8	3500	8200	1.80
TF00-050	TF02-350	50	75	192	13	89.5	112	94	M8	6200	16200	2.80
TF00-060	TF02-360	60	90	209	18	95.5	134	112	M10	7600	20000	4.92

Tel. 01908 511733

www.euro-bearings.com

EURO-BEARINGS LTD

SQUARE MID FLANGED TANDEM BUSHES

These tandem (i.e double length) square flanged ball bushings are made to the European dimensions and have the same characteristics and loadings as our popular range of round flanged ball bushings.

The flange provides a simple but robust mounting system. The ball bushing has 2 integral shaft wiping seals & a polyamide ball retainer.

The centre flange can be bolted to the bulkhead and therefore there is no need for a housing. The double length provides greater load capacity.

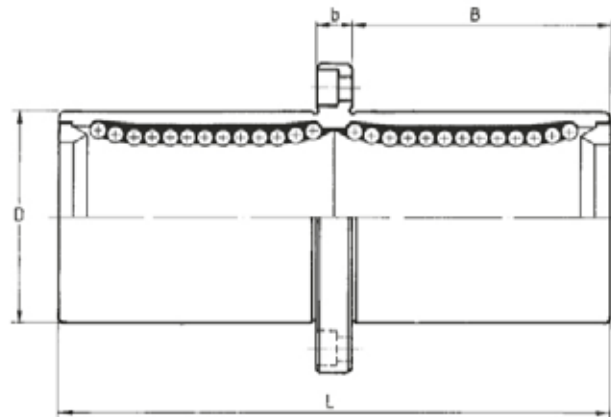
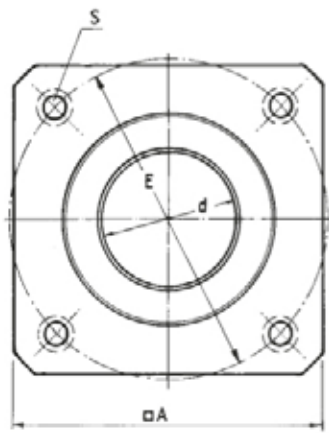

PART (2 seals)	d	D	L	b	B	A	E	S	Load C (N)	Load C ₀ (N)	Weight (kg)
LMEM08UU	8	16	46	5	20.5	25	24	M3	430	780	0.05
LMEM12UU	12	22	61	6	27.5	32	32	M4	655	1200	0.08
LMEM16UU	16	26	68	6	31	35	36	M4	1230	2350	0.16
LMEM20UU	20	32	80	8	36	42	43	M5	1400	2750	0.23
LMEM25UU	25	40	112	8	52	50	51	M5	1560	3140	0.48
LMEM30UU	30	47	123	10	56.5	60	62	M6	2490	5490	0.57
LMEM40UU	40	62	151	13	69	75	80	M8	3430	8040	1.38

TRIPLE ROUND FLANGED BALL BUSHINGS

These triple flanged ball bushings are made with a grease nipple in the middle of the two recirculating ball areas for ease of lubrication.

The flange and outer ring are made from one billet of steel thereby giving enormous strength to the design. Also due to their length they offer higher rigidity than using multiple standard ball bushings.

They are available with two seals and a plastic ball retainer as shown below (FS92-3..).

For all components in stainless steel the ordering reference is FS90-5..

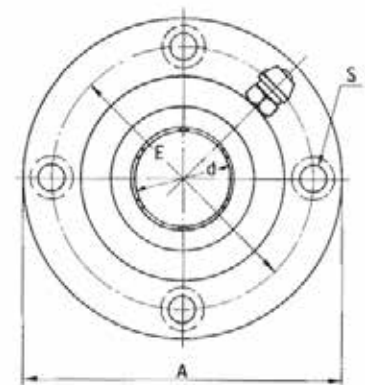
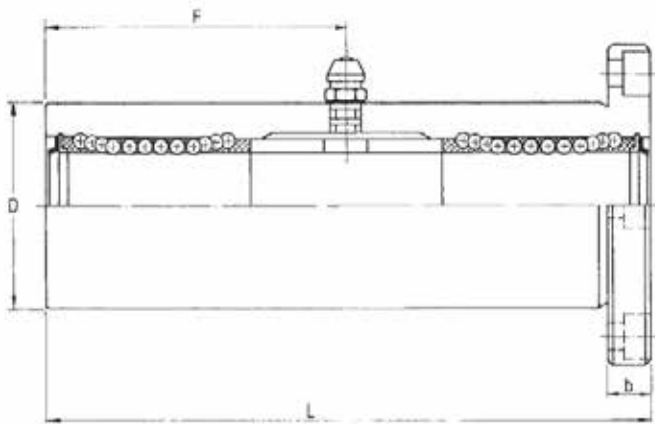

PART (2 seals)	d	D	L	b	A	E	F	S	Load C (N)	Load C ₀ (N)	Weight (kg)
FS92-308	8	19	66	6	40	29	29	M4	440	800	0.135
FS92-312	12	26	84	6	46	36	41	M4	830	1600	0.248
FS92-316	16	32	103	8	54	43	51	M5	1250	2400	0.412
FS92-320	20	40	118	8	62	51	59	M5	1430	2800	0.752
FS92-325	25	45	165	10	74	60	82.5	M6	1590	3200	1.244
FS92-330	30	52	182	10	82	67	91	M6	2540	5600	1.636
FS92-340	40	65	230	13	101	83	115	M8	3500	8200	2.950
FS92-350	50	85	290	18	129	107	145	M10	6200	16200	6.860

TRIPLE CENTRE FLANGED BUSHES

This bushing is provided with a grease nipple in the centre of the bushing for ease of lubrication. It is longer than the TF type and therefore offers higher rigidity and accuracy.

The standard type has two seals and a plastic ball retainer. Part number: TS02-3..

If required the ball bushings are available with all parts manufactured from steel (unsealed). Ordering reference number: TS00-0..

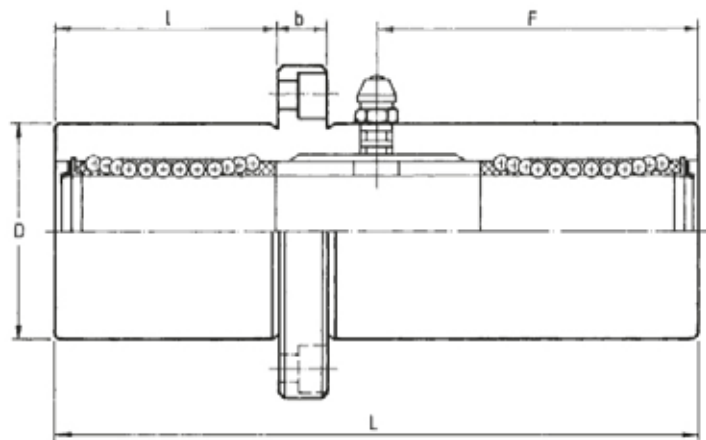
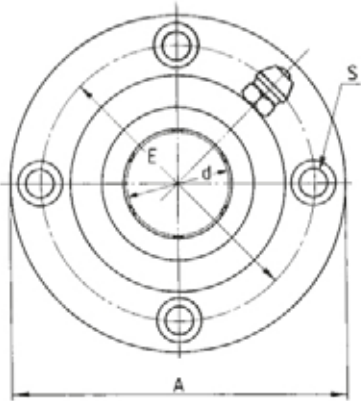

PART (2 seals)	d	D	L	b	l	A	E	F	S	Load C (N)	Load C ₀ (N)	Weight (kg)
TS02-308	8	19	66	6	22	40	29	29	M4	440	800	0.135
TS02-312	12	26	84	6	28	46	36	41	M4	830	1600	0.248
TS02-316	16	32	103	8	35	54	43	51	M5	1250	2400	0.412
TS02-320	20	40	118	8	40	62	51	59	M5	1430	2800	0.752
TS02-325	25	45	165	10	55	74	60	82.5	M6	1590	3200	1.244
TS02-330	30	52	182	10	61	82	67	91	M6	2540	5600	1.636
TS02-340	40	65	230	13	77	101	83	115	M8	3500	8200	2.950
TS02-350	50	85	290	18	97	129	107	145	M10	6200	16200	6.860

REVERSE FLANGED BALL BUSHINGS

This ball bushing is an alternative version of the flanged ball bushings. The special four-bolt flange allows a reversed mounting, in which the shorter part of the bushing is inserted into the housing bore and the longer part is protruding.



The reversed-flange ball bushings are available with two seals and a plastic ball retainer as FK22-3.. (standard length) and as FK42-3.. (tandem length).

If required the ball bushing is available unsealed - part numbers FK20-3.. and FK40-3..

They are also available with all parts manufactured from steel. Ordering reference number FK22-0.. or FK42-0..

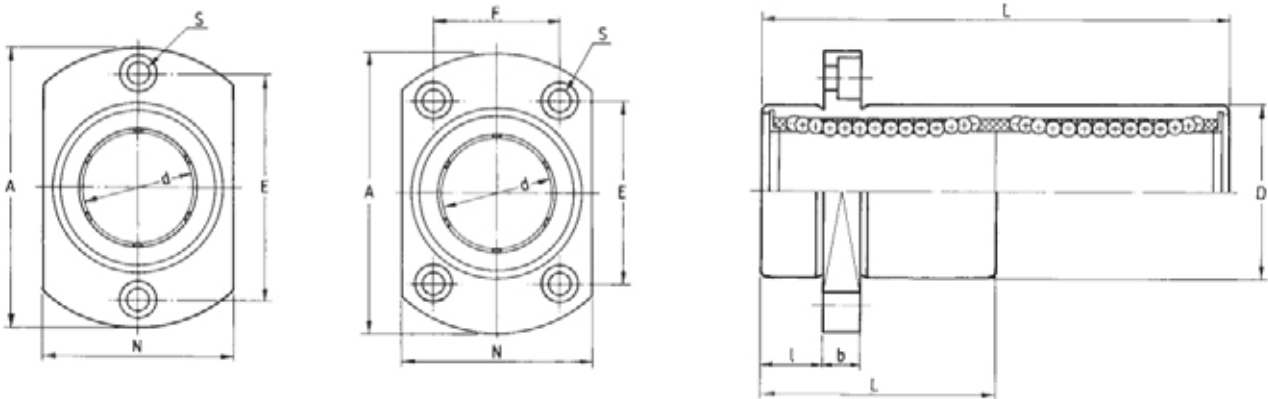

PART (2 seals)	d	D	L	b	l	A	N	E	F	S	Load C (N)	Load C ₀ (N)	Weight (kg)
FK22-306	6	12	19	5	5	28	18	20		M3	206	265	0.02
FK22-308	8	15	24	5	5	32	21	24		M3	280	400	0.03
FK22-310	10	19	29	6	6	40	25	29		M4	372	549	0.06
FK22-312	12	21	30	6	6	42	27	32		M4	520	800	0.07
FK22-316	16	28	37	6	6	48	34	31	22	M4	790	1200	0.11
FK22-320	20	32	42	8	8	54	38	36	24	M5	900	1400	0.17
FK22-325	25	40	59	8	8	62	46	40	32	M5	1000	1600	0.33
FK22-330	30	45	64	10	10	74	51	49	35	M6	1600	2800	0.39
FK22-340	40	60	80	13	13	96	96	55.1	55.1	M8	2200	4100	1.06
FK22-350	50	80	100	13	13	116	116	69.3	69.3	M8	3900	8100	2.20

PART (2 seals)	d	D	L	b	l	A	N	E	F	S	Load C (N)	Load C ₀ (N)	Weight (kg)
FK42-306	6	12	35	5	5	28	18	20		M3	323	530	0.03
FK42-308	8	15	45	5	5	32	21	24		M3	440	800	0.05
FK42-310	10	19	55	6	6	40	25	29		M4	588	1100	0.09
FK42-312	12	21	57	6	6	42	27	32		M4	830	1600	0.10
FK42-316	16	28	70	6	6	48	34	31	22	M4	1250	2400	0.18
FK42-320	20	32	80	8	8	54	38	36	24	M5	1430	2800	0.25
FK42-325	25	40	112	8	8	62	46	40	32	M5	1590	3200	0.53
FK42-330	30	45	123	10	10	74	51	49	35	M6	2540	5600	0.65
FK42-340	40	60	151	13	13	96	96	55.1	55.1	M8	3500	8200	1.57
FK42-350	50	80	192	13	13	116	116	69.3	69.3	M8	6200	16200	3.60

REVERSE ROUND FLANGED BALL BUSHES

These ball bushings are designed with a flange that allows the bush to be mounted against a bulkhead. This reverse mounting means that the shorter part of the bushing is inserted into the housing (or bulkhead) and the longer part is protruding.

The fixing holes are counterbored on the opposite side of the flange to the usual arrangement to allow for this specific type of fixing. In addition, they are easily re-lubricated via the nipple (see drawing below)



The standard type has 2 seals and a plastic cage.

Part number FK62-3..

It is also available with all parts in steel.

Part number FK60-0..

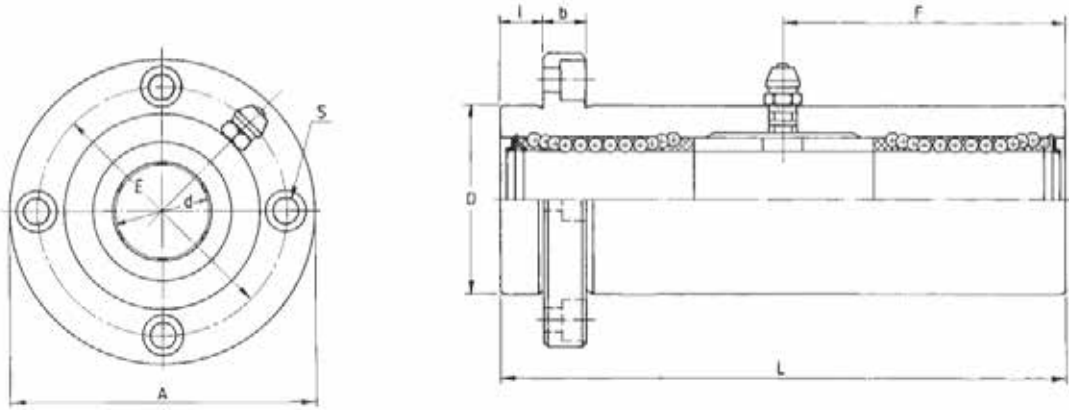

PART (2 seals)	d	D	L	b	I	A	E	F	S	Load C (N)	Load C ₀ (N)	Weight (kg)
FK62-308	8	19	66	6	6	40	29	29	M4	440	800	0.135
FK62-312	12	26	84	6	6	46	36	41	M4	830	1600	0.284
FK62-316	16	32	103	8	8	54	43	51	M5	1250	2400	0.412
FK62-320	20	40	118	8	8	62	51	59	M5	1430	2800	0.752
FK62-325	25	45	165	10	10	74	60	82.5	M6	1590	3200	1.244
FK62-330	30	52	182	10	10	82	67	91	M6	2540	5600	1.636
FK62-340	40	65	230	13	13	101	83	115	M8	3500	8200	2.950
FK62-350	50	85	290	18	18	129	107	145	M10	6200	16200	6.860

COMBINED LINEAR & RADIAL BUSHES

These rotating and sliding ball bushings allow both types of high precision motion. These motions can occur either separately or simultaneously. Given the same shaft size, the outside diameter of these ball bushings is much smaller than a combination of a standard ball bushing and a radial ball or roller bearing.

We now offer these bushes in two forms: 0662 Series with brass cage & RK series with circlip grooves in outer ring & steel cage.

0662 & RK00 do not have a flange, while RK20 has a square flange but no circlip grooves.



0662-...

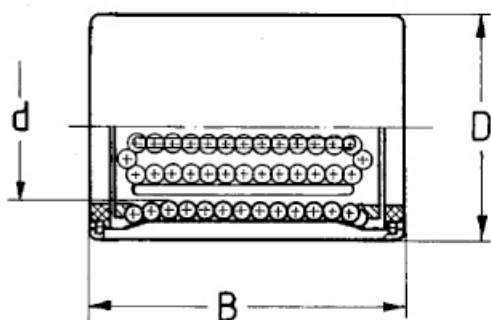

RK20-0..

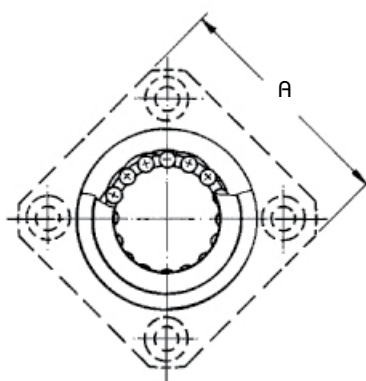

RK00-0..

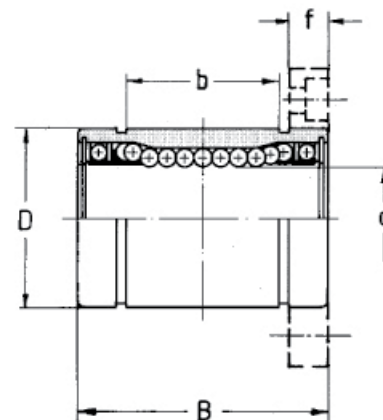

PART (Plastic seals)	PART (Steel shields)	d	D	B	b	A	f	E	S	Load C (N)	Load C ₀ (N)	Max RPM	Weight (kg)	Circlip Size
0662-006		6	10	19						46	100	1000	0.008	
	RK.0-006	6	12	19	11	22	5	20	3.5	78	176	300	0.010	12x1
0662-008		8	14	23						106	228	900	0.014	
	RK.0-008	8	15	24	15	25	5	24	3.5	137	314	300	0.015	15x1
0662-012		12	19	31						275	600	750	0.031	
	RK.0-012	12	21	30	20	32	6	32	4.5	274	588	300	0.040	21x1.2
0662-016		16	25	35						455	900	550	0.060	
	RK.0-016	16	28	37	23	37	6	38	4.5	451	882	250	0.065	28x1.5
0662-020		20	30	42						560	1220	450	0.100	
	RK.0-020	20	32	42	27	42	8	43	5.5	647	1180	250	0.110	33x1.5
0662-025		25	37	54						900	1900	350	0.200	
	RK.0-025	25	40	59	37	50	8	51	5.5	882	1860	250	0.210	42x1.75
0662-030		30	42	64						1180	2700	300	0.270	
	RK.0-030	30	45	64	40.5	58	10	60	6.6	1180	2650	200	0.290	46x1.75
0622-040		40	55	78						1930	4400	200	0.565	

TANDEM BALL BUSHINGS

These ball bushings have the same boundary dimensions as the standard ball bushings but differ in their length.

This bushing offers the advantage of using just one double-length bush in place of two standard ball bushings.

Each tandem unit has two ball recirculating 'zones' thereby virtually doubling their load capacity and their accuracy for a given shaft size.

They are available with solid end plates & all components made from steel - reference TK00-0..

Or with two seals & a plastic ball retainer - reference TK02-3..

Alternatively all parts can be made from stainless steel with stainless steel endplates. Reference TK00-5..

NB. Load capacity is for vertical loads only.

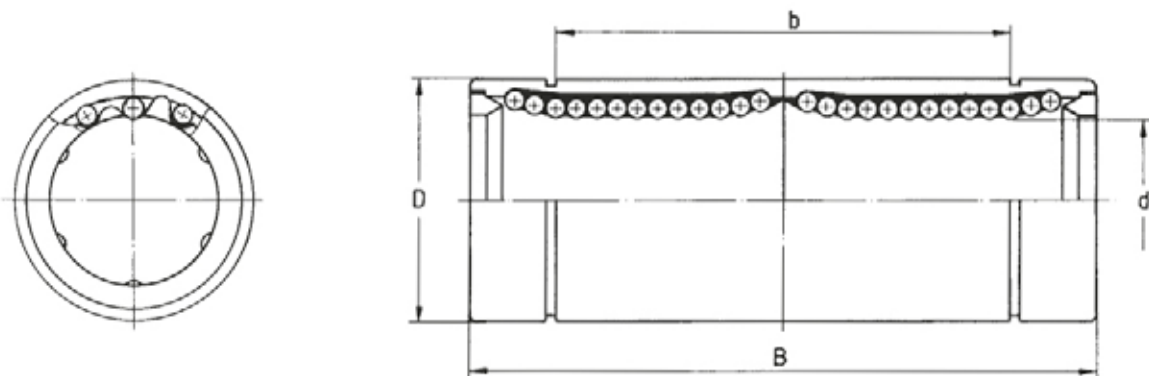

PART (no seals)	PART (2 seals)	d	D	B	b	Ball Circuits	Load C (N)	Load C ₀ (N)	Weight (kg)	Circlip Size
TK00-008	TK02-308	8	16	46	30.5	4	430	820	0.04	16x1
TK00-012	TK02-312	12	22	61	43	4	830	1580	0.08	22x1.2
TK00-016	TK02-316	16	26	68	47	4	940	1820	0.12	27x1.2
TK00-020	TK02-320	20	32	80	57.5	5	1400	2800	0.18	33x1.5
TK00-025	TK02-325	25	40	112	78	6	1600	3200	0.43	42x1.75
TK00-030	TK02-330	30	47	123	100	6	2550	5600	0.62	48x1.75
TK00-040	TK02-340	40	62	151	116.5	6	3500	8200	1.40	62x2
TK00-050	TK02-350	50	75	192	149.5	6	6200	16200	2.32	75x2.5

ALUMINIUM LINEAR HOUSINGS

These lightweight yet heavy duty aluminium sets offer high accuracy. They consist of a corrosion resistant, highly rigid aluminium housing and a double sealed ball bushing.

The user can choose from all steel ball bushings, ball bushing with plastic cage, or our super ball bushings.

High speeds and accelerations are possible.

Permutations available: (example is for 20mm bore)

Ball bushing with plastic cage and seals: AE35-220

All steel ball bushing without seals: AE35-020

All STAINLESS steel bushing without seals: AE35-520

The sealed type (AE35-2..) can operate in temperatures of up to 80°C.

For high temperature applications specify the steel / unsealed version AE35-0..

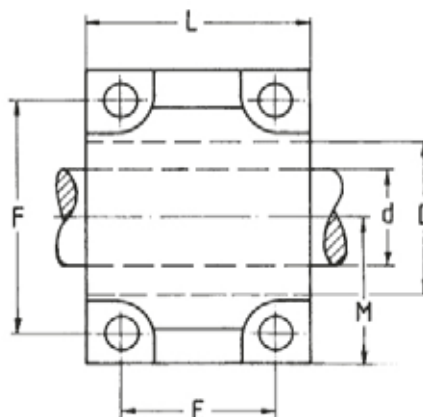
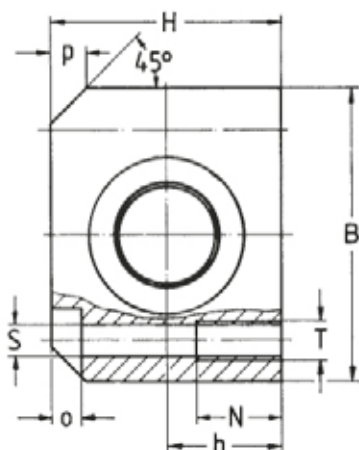

PART	d	B	H	h	L	D	E	F	M	S	T	N	O	P	Load C (N)	Load C ₀ (N)	Weight (kg)
AE35-212	12	42	35	18	39	22	23	32	21	4.3	M5	11	4	5	570	800	0.14
AE35-216	16	52	42	22	43	26	26	40	26	5.3	M6	13	5	6	800	940	0.20
AE35-220	20	60	50	25	54	32	32	45	30	6.6	M8	18	6	7	900	1400	0.38
AE35-225	25	76	60	30	67	40	40	60	38	8.4	M10	22	8	9	1100	1700	0.73
AE35-230	30	86	70	35	79	47	45	68	43	8.4	M10	22	8	10	1700	3000	1.12
AE35-240	40	108	90	45	91	62	58	86	54	10.5	M12	26	10	12	2300	4700	2.30
AE35-250	50	130	105	50	113	75	50	108	65	13.5	M16	34	12	13	4100	8300	3.80

Available with ± 0.02 mm tolerance for side mounting

These Aluminium Sets are also available slotted as Adjustable Type sets. Order part no AE36- ... with suffix depending on ball bushing required (see above). In general, because of the close tolerances of ball bushings fitted to our aluminium sets we do not recommend the use of the adjustable type.

Tel. 01908 511733

www.euro-bearings.com

EURO-BEARINGS LTD

OPEN ALUMINIUM LINEAR HOUSINGS

When mounting these Open Type Aluminium Sets the four securing holes should be provided with bolts to achieve the maximum load capacity and the best rigidity for every mounting position.

The housings are available equipped with different ball bushings.

Permutations available: (example is for 20mm bore)

Ball bushing with plastic cage and seals: AE37-220
 All steel ball bushing without seal: AE37-020
 All STAINLESS steel bushing without seal AE37-520



The sealed type (AE37-2..) can operate up to 80° C.
 For high temperature applications specify the steel / unsealed version AE37-0..

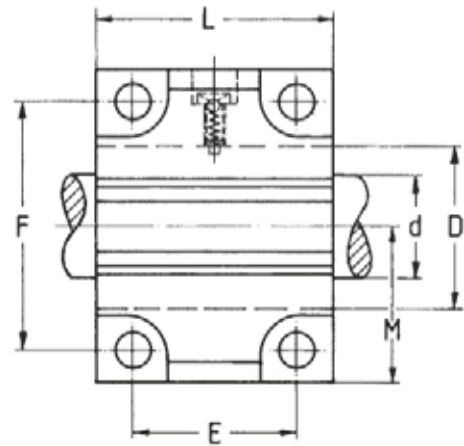
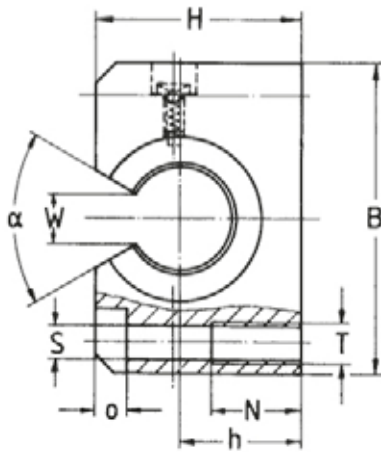

PART	d	B	H	h	L	D	E	F	M	S	T	N	O	W	α	Load C (N)	Load C ₀ (N)	Weight (kg)
AE37-212	12	42	28	18	39	22	23	32	21	4.3	M5	11	4	7.5	78	570	800	0.10
AE37-216	16	52	35	22	43	26	26	40	26	5.3	M6	13	5	10	78	580	870	0.17
AE37-220	20	60	42	25	54	32	32	45	30	6.6	M8	18	6	10	60	900	1400	0.28
AE37-225	25	76	51	30	67	40	40	60	38	8.4	M10	22	8	12.5	60	1100	1700	0.60
AE37-230	30	86	60	35	79	47	45	68	43	8.4	M10	22	8	12.5	50	1700	3000	0.90
AE37-240	40	108	77	45	91	62	58	86	54	10.5	M12	26	10	16.8	50	2300	4700	1.70
AE37-250	50	130	88	50	113	75	50	108	65	13.5	M16	34	12	21	50	4100	8300	2.80

If the direction of the load is not acting at right angles to the mounting surface please refer to notes on page 5.

Available with ± 0.02 mm tolerance for side mounting

These Aluminium Sets are also available slotted as Adjustable Type sets. Order part no AE38- ... with suffix depending on ball bushing required (see above). In general, because of the close tolerances of ball bushings fitted to our aluminium sets we do not recommend the use of the adjustable type.

CAST IRON LINEAR HOUSINGS

These bearing housings are manufactured from spheroidal graphite cast iron. The standard ball bushings are fitted to the closed (LE65-) and adjustable (LE66-) housings using external circlips located in the circlip grooves on the exterior of the ball bushing.

The design of the housing allows a mounting position that enables the load to act in any direction providing a high rigidity. The high precision of these units ensures full mutual interchangeability.

The housings can be fitted with either a sealed linear bearing with plastic cage (LE65-2..) or with an all steel linear bearing (LE65-0..).



Closed:
LE65-0.. (without seals)
LE65-2.. (with seals)

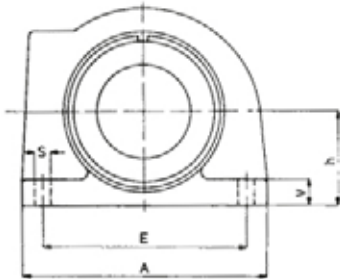

Adjustable:
LE66-0.. (without seals)
LE66-2.. (with seals)

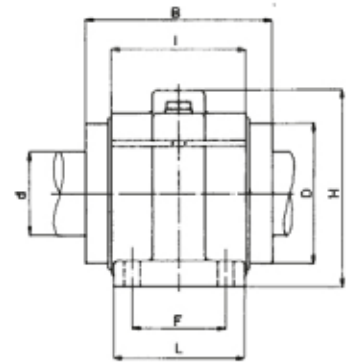
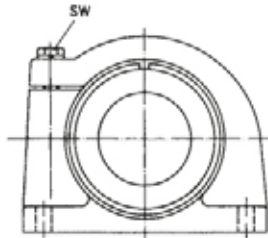

PART (Closed)	PART (Adjustable)	d	D	h	H	B	A	L	I	E	F	S	V	SW	Weight (kg)
LE65-.08	LE66-.08	8	16	15	28	25	32	28	14	25	20	3.4	5	5.5	0.09
LE65-.12	LE66-.12	12	22	18	35	32	42	32	20	32	23	4.5	5.5	7	0.16
LE65-.16	LE66-.16	16	26	22	42	36	50	35	22	40	26	4.5	6.5	7	0.24
LE65-.20	LE66-.20	20	32	25	50	45	60	42	28	45	32	4.5	8	7	0.43
LE65-.25	LE66-.25	25	40	30	60	58	74	54	40	60	40	5.5	9	8	0.86
LE65-.30	LE66-.30	30	47	35	70	68	84	60	48	68	45	6.6	10	10	1.34
LE65-.40	LE66-.40	40	62	45	90	80	108	78	56	86	58	9	12	13	2.67
LE65-.50	LE66-.50	50	75	50	105	100	130	70	72	108	50	9	14	13	3.74
LE65-.60	LE66-.60	60	90	60	125	125	160	92	95	132	65	11	15	17	6.77
LE65-.80	LE66-.80	80	120	80	170	165	200	122	125	170	90	13	22	19	15.50

OPEN CAST IRON LINEAR HOUSINGS

These spheroidal graphite cast iron housings are equipped with open type ball bushings that are secured against displacement by a grub screw. This enables easy interchange of the bushings.

The housings can be mounted so that the load is able to act in any direction.

The high precision of these units ensures full mutual interchangeability.

The housing can be fitted with either a sealed linear bearing with plastic cage (LE67-2..) or with an all steel linear bearing (LE67-0..).



Open:
LE67-0.. (without seals)
LE67-2.. (with seals)

Adjustable:
LE68-0.. (without seals)
LE68-2.. (with seals)

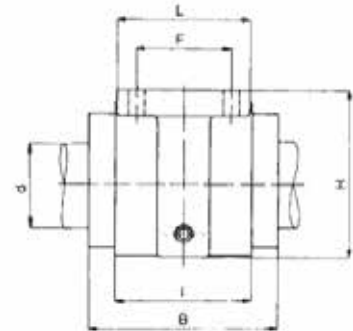
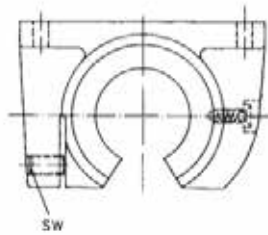
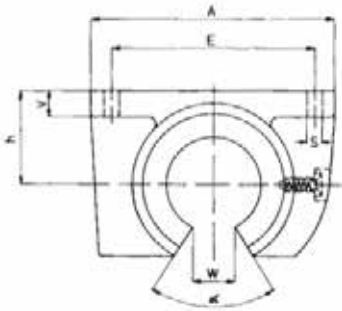

PART (Open)	PART (Adjustable)	d	h	H	B	A	L	I	E	F	S	V	SW	W	α	Weight (kg)
LE67-.12	LE68-.12	12	18	28	32	42	32	20	32	23	4.5	5.5	2.5	7.5	78	0.13
LE67-.16	LE68-.16	16	22	35	36	50	35	22	40	26	4.5	6.5	2.5	10	78	0.21
LE67-.20	LE68-.20	20	25	42	45	60	42	28	45	32	4.5	8	2.5	10	60	0.36
LE67-.25	LE68-.25	25	30	51	58	74	54	40	60	40	5.5	9	3	12.5	60	0.73
LE67-.30	LE68-.30	30	35	60	68	84	60	48	68	45	6.6	10	3	12.5	50	1.18
LE67-.40	LE68-.40	40	45	77	80	108	78	56	86	58	9	12	4	16.8	50	2.30
LE67-.50	LE68-.50	50	50	88	100	130	70	72	108	50	9	14	5	21	50	3.10
LE67-.60	LE68-.60	60	60	105	125	160	92	95	132	65	11	15	5	27.2	54	5.78
LE67-.80	LE68-.80	80	80	140	165	200	122	125	170	90	13	22	6	36.3	54	12.80

TANDEM ALUMINIUM LINEAR HOUSINGS

These units are manufactured from aluminium alloy and incorporate two ball bushings in line.

Using these aluminium tandem sets eliminates the difficulty of perfectly aligning two single housings.

As with our other housings the tandem sets are available with different types of ball bushings.

The various options (shown here for a 20mm shaft) are:

- Ball bushing with plastic cage and seals: TE85-220
- All steel ball bushing without seal: TE85-020
- All STAINLESS steel bushing without seal TE85-520

The sealed types can operate up to 80°C. Above this temperature specify unsealed (TE85-0..).

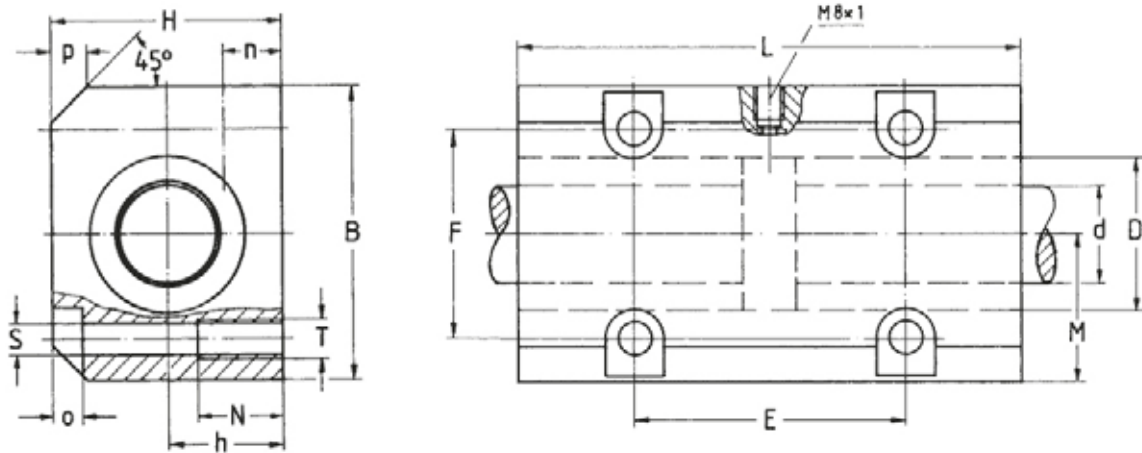
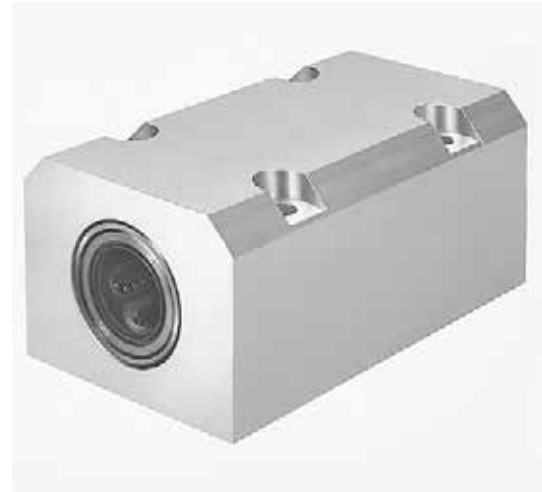

PART	d	B	H	h	L	D	E	F	M	S	T	N	n	o	p	Load C=C ₀ (N)	Weight (kg)
TE85-212	12	42	35	18	76	22	40	30	21	5.3	M6	13	10	4	5	1100	0.32
TE85-216	16	52	42	22	84	26	45	36	26	5.3	M6	13	12	5	6	1300	0.48
TE85-220	20	60	50	25	104	32	55	45	30	6.6	M8	18	13	6	7	1750	0.84
TE85-225	25	76	60	30	130	40	70	54	38	8.4	M10	22	15	8	9	1950	1.62
TE85-230	30	86	70	35	152	47	85	62	43	10.5	M12	26	16	8	10	3100	2.46
TE85-240	40	108	90	45	176	62	100	80	54	13.5	M16	34	20	10	12	4300	4.79
TE85-250	50	130	105	50	224	75	125	100	65	13.5	M16	34	20	12	13	7600	8.06

Available with ±0.02 mm tolerance for side mounting

These Aluminium Sets are also available slotted as Adjustable Type sets. Order part no TE32- ... with suffix depending on ball bushing required (see above).

The mounting holes are then the same (E F & T) as the TE33 – see page 30.

In general, because of the close tolerances of ball bushings fitted to our Aluminium sets we do not recommend the use of the adjustable type.

OPEN TANDEM ALUMINIUM LINEAR HOUSINGS

Two open type ball bushings are incorporated into these precision aluminium alloy housings.

Using these aluminium tandem sets eliminates the need to precisely mount two single housings.

As with our other sets the tandem sets are available with different types of ball bushings.

Permutations available: (example is for 20mm bore)

- Ball bushing with plastic cage and seals: TE33-220
- All steel ball bushing without seals: TE33-020
- All STAINLESS steel bushing without seal TE33-520

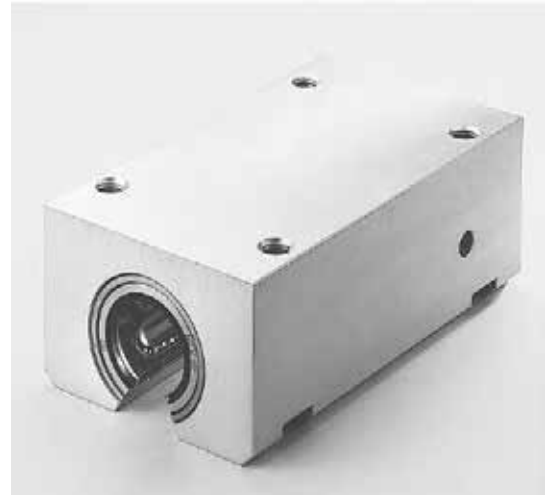

The sealed types can operate up to 80°C.
For high temperature applications specify the unsealed version (TE33-0..).

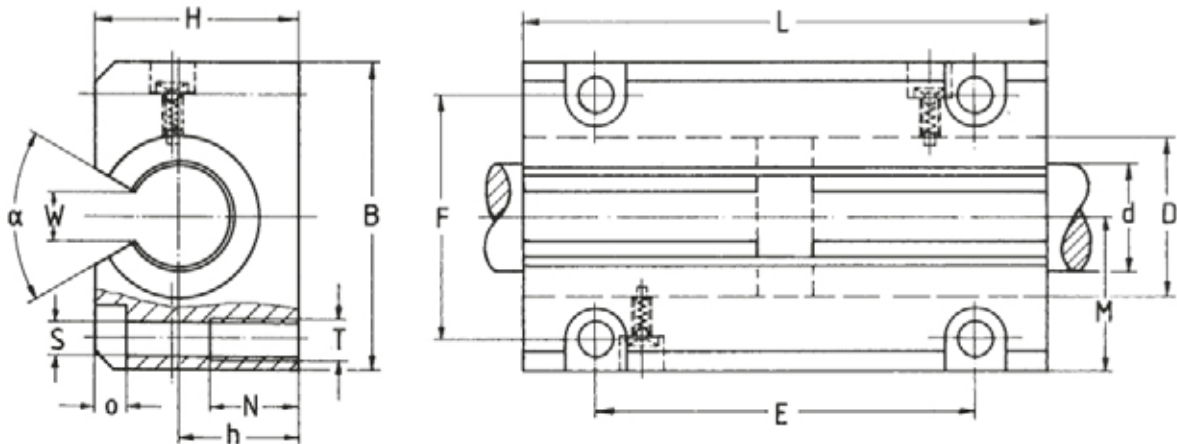

PART	d	B	H	h	L	D	E	F	M*	S	T	N	O	W	α	Load C=C ₀ (N)	Weight (kg)
TE33-212	12	42	28	18	76	22	56	32	21	4.3	M5	11	4	7.5	78	1100	0.26
TE33-216	16	52	35	22	84	26	64	40	26	5.3	M6	13	5	10	78	1300	0.38
TE33-220	20	60	42	25	104	32	76	45	30	6.6	M8	18	6	10	60	1750	0.67
TE33-225	25	76	51	30	130	40	94	60	38	8.4	M10	22	8	12.5	60	1950	1.31
TE33-230	30	86	60	35	152	47	106	68	43	8.4	M10	22	8	12.5	50	3100	2.01
TE33-240	40	108	77	45	176	62	124	86	54	10.5	M12	26	10	16.8	50	4300	3.93
TE33-250	50	130	88	50	224	75	160	108	65	13.5	M16	34	12	21	50	7600	6.20

*Available with ±0.02 mm tolerance for side mounting

These Aluminium Sets are also available slotted as Adjustable Type sets. Order part no TE34- ... with suffix depending on ball bushing required (see above). In general, because of the close tolerances of ball bushings fitted to our aluminium sets we do not recommend the use of the adjustable type.

FLANGED LINEAR HOUSINGS

The flanged linear housings consist of a spheroidal graphite cast iron housing containing a ball bushing. The housing can be attached vertically or horizontally to the supporting surface.

The incorporated ball bushing is supported over its whole recirculating length.

As with our housings, these flanged sets are available with different types of ball bushings.

Permutations available: (example is for 20mm bore)

Ball bushing with plastic cage and seals: FE81-220

All steel ball bushing without seal: FE81-020

All STAINLESS steel bushing without seal FE81-520

The sealed types can operate up to 80°C.

For high temperature applications specify the unsealed version (FE81-0..).

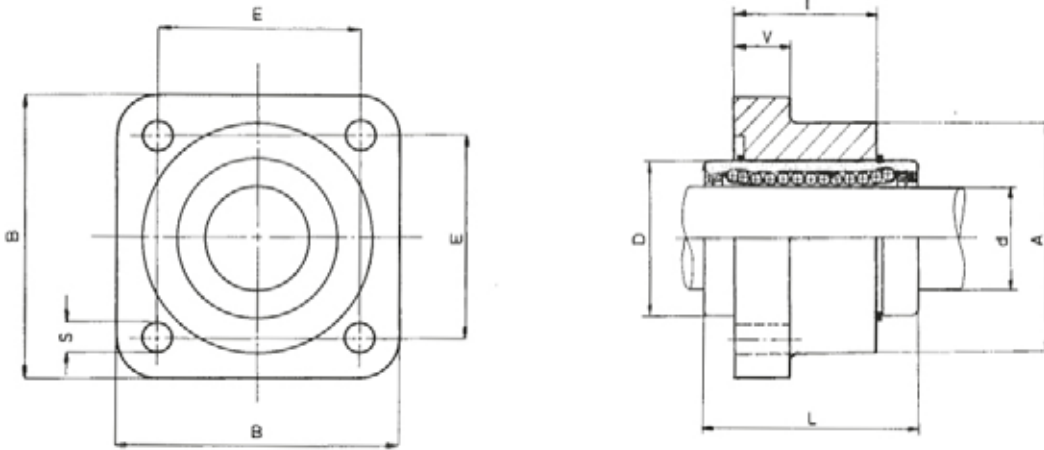

PART (no seals)	PART (2 seals)	d	B	L	I	D	A	E	S	V	Weight (kg)
FE81-012	FE81-212	12	42	32	22	22	30	30	5.5	6	0.14
FE81-016	FE81-216	16	50	36	24	26	36	35	5.5	8	0.23
FE81-020	FE81-220	20	60	45	30	32	42	42	6.6	10	0.38
FE81-025	FE81-225	25	74	58	42	40	54	54	6.6	12	0.78
FE81-030	FE81-230	30	84	68	50	47	62	60	9	14	1.23
FE81-040	FE81-240	40	108	80	59	62	82	78	11	16	2.31
FE81-050	FE81-250	50	130	100	75	75	100	98	11	18	4.32
FE81-060	FE81-260	60	160	125	99	90	118	120	14	22	7.94
FE81-080	FE81-280	80	200	165	130	120	156	155	14	26	16.75

For applications using rail supported shafts these flanged linear sets are available as open type sets. Please refer to the table above for housing detail and the tables for open type ball bushings for the bushing details

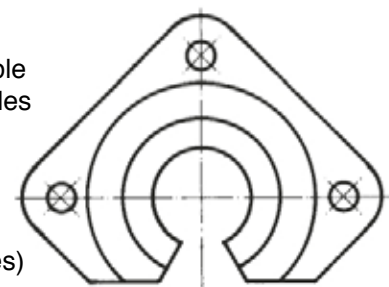

Part number becomes FE83-... (suffixes as above for different ball bushing types)

TANDEM FLANGED ALUMINIUM HOUSINGS

These aluminium linear sets contain two ball bushings in line. The housing has mounting holes on one face to enable the unit to be bolted to a bulkhead as is shown in the drawing below.

As with our other sets the flanged sets are available with different types of ball bushings.

Permutations available: (example is for 20mm bore)

Ball bushing with plastic cage and seals: TF83-220
 All steel ball bushing without seal: TF83-020
 All STAINLESS steel bushing without seal TF83-520

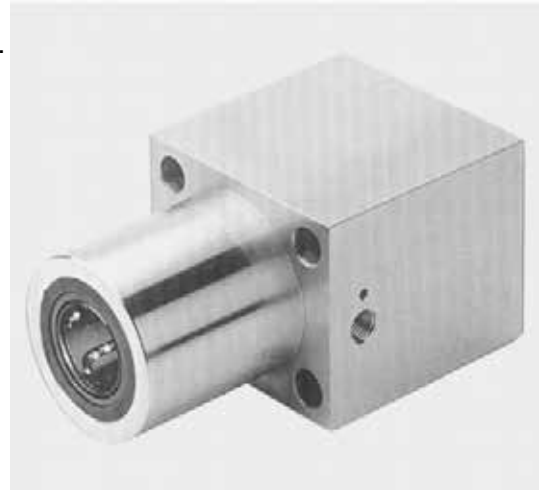

The sealed types can operate up to 80° C.
 For higher temperatures specify the unsealed type (TF83-0..).

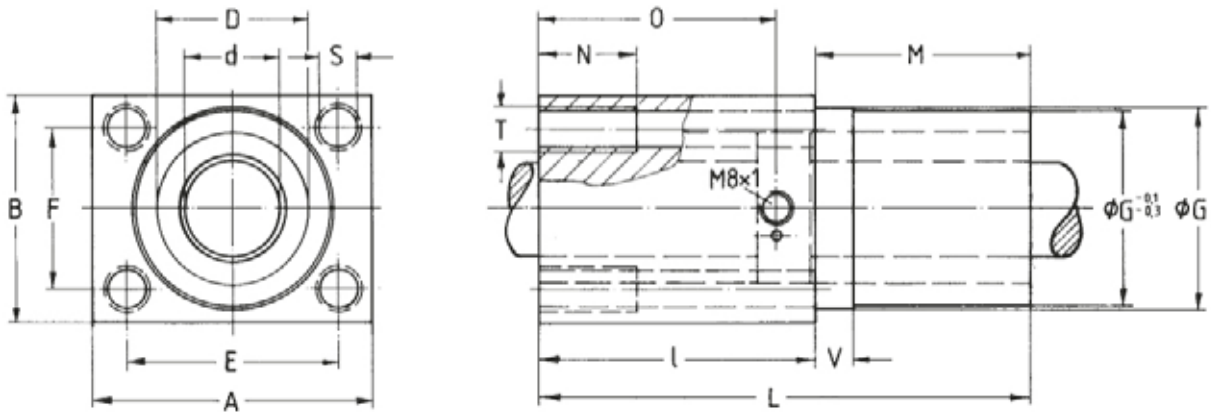

PART	d	D	G*	A	B	L	E	F	S*	T	I	M	N	O	V	Load C=C ₀ (N)	Weight (kg)
TF83-212	12	22	30	42	34	76	32	24	5.3	M6	46	30	13	35	10	1100	0.22
TF83-216	16	26	35	50	40	84	38	28	6.6	M8	50	34	18	40	10	1300	0.33
TF83-220	20	32	42	60	50	104	45	35	8.4	M10	60	44	22	50	10	1750	0.58
TF83-225	25	40	52	74	60	130	56	42	10.5	M12	73	57	26	63	10	1950	1.15
TF83-230	30	47	61	84	70	152	64	50	13.5	M16	82	70	34	74	20	3100	1.70

*We recommend the bore of the corresponding housing to be H7

+ locating screw DIN912 – 8.8

OPEN SIDED ALUMINIUM LINEAR HOUSINGS

If the direction of the load is acting towards the open side of an open type ball bushing the load capacity is severely reduced.

These open sided linear sets have been developed to overcome this issue and are designed to optimise rigidity and load capacity for side mounted applications.

As with our other sets these sets are available with different types of ball bushings.

Permutations available: (example is for 20mm bore)

Ball bushing with plastic cage and seals: LE71-220

All steel ball bushing without seal: LE71-020

All STAINLESS steel bushing without seal LE71-520

The sealed types can operate up to 80°C.

For higher temperatures specify the unsealed type (LE71-020).

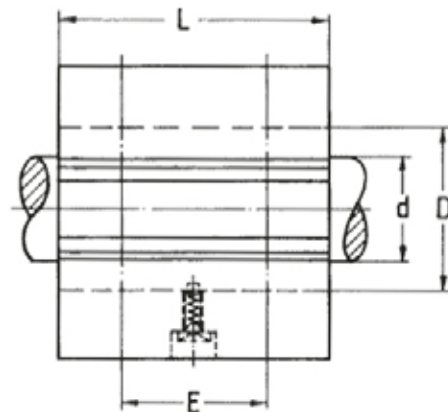
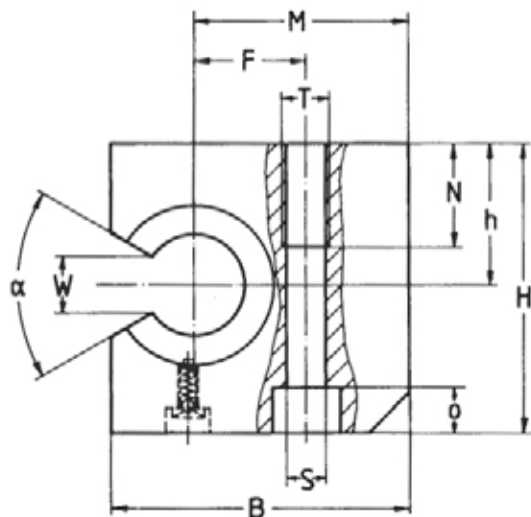
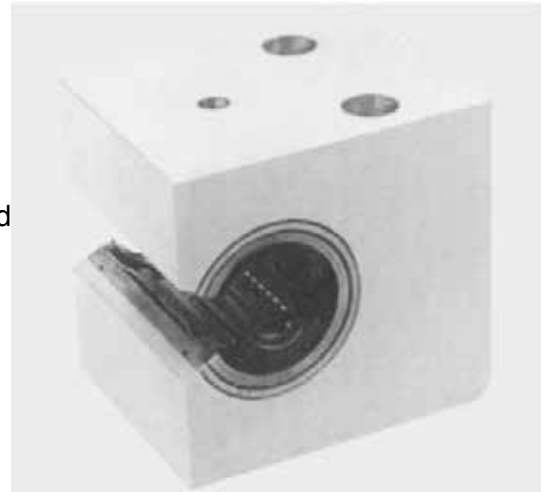

PART	d	B	H	h	L	D	E	F	M	S	T	N	o	W	α	Load ⁺ C (N)	Load ⁺ C ₀ (N)	Weight (kg)
LE71-220	20	60	60	30	54	32	30	22	43	8.4	M10	22	9	17	60	900	1400	0.40
LE71-225	25	75	72	35	67	40	36	28	54	10.5	M12	26	11	21	60	1100	1700	0.75
LE71-230	30	86	82	40	79	47	42	34	61	13.5	M16	34	13	21	50	1700	3000	1.15
LE71-240	40	110	100	45	91	62	48	43	78	16.0	M20	43	14	27	50	2300	4700	2.00
LE71-250	50	127	115	50	113	75	62	50	89	17.5	M20	43	17	33	50	4100	8300	3.50

•Available with ± 0.02 tolerance for side mounting

+ If the direction of the load is not acting at 90° to the mounting surface please refer to the notes on page 5.

These aluminium sets are also available slotted as adjustable type sets. Order part no LE72- ... with suffix depending on ball bushing required (see above). In general, because of the close tolerances of ball bushings fitted to our aluminium sets we do not recommend the use of the adjustable type.

COMPACT ALUMINIUM LINEAR HOUSINGS

These aluminium sets are equipped with compact ball bushings.

There are two types, single length (AG27) or tandem (double) length (AG85).

To order the sets with standard steel ball bushings use part numbers shown in the table below e.g. AG27-220

To order the sets with STAINLESS STEEL ball bushings modify the part number to read (for example) AG27-520 or AG85-520

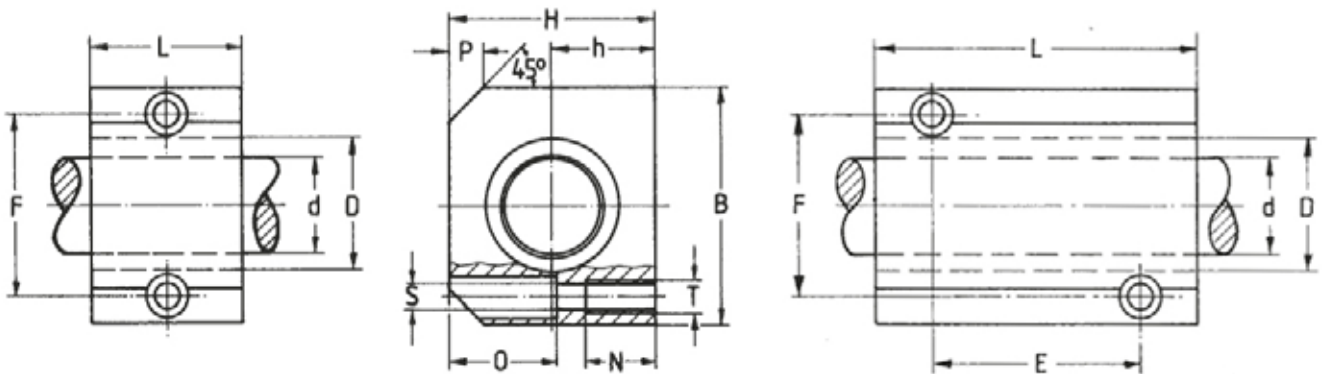

PART	PART (Tandem)	d	B	H	h	L	D	E	F	S	T	N	O	P	Load C (N)	Load C ₀ (N)	Weight (kg)
AG27-212		12	40	33	17	28	19		29	4.3	M5	11	17	5	695	510	0.08
	AG85-212	12	40	33	17	60	19	35	29	4.3	M5	11	17	5	1140	1020	0.17
AG27-216		16	45	38	19	30	24		34	4.3	M5	11	20	6	930	630	0.11
	AG85-216	16	45	38	19	65	24	40	34	4.3	M5	11	20	6	1530	1270	0.23
AG27-220		20	53	45	23	30	28		40	5.3	M6	13	23	7	1160	800	0.15
	AG85-220	20	53	45	23	65	28	45	40	5.3	M6	13	23	7	1900	1600	0.32
AG27-225		25	62	54	27	40	35		48	6.6	M8	18	28	9	2120	1560	0.27
	AG85-225	25	62	54	27	85	35	55	48	6.6	M8	18	28	9	3450	3150	0.56
AG27-230		30	67	60	30	50	40		53	6.6	M8	18	31	10	3150	2700	0.40
	AG85-230	30	67	60	30	105	40	70	53	6.6	M8	18	31	10	5200	5400	0.82
AG27-240		40	87	76	39	60	52		69	8.4	M10	22	38	12	5300	4400	0.75
	AG85-240	40	87	76	39	125	52	85	69	8.4	M10	22	38	12	9000	9000	1.58
AG27-250		50	103	92	47	70	62		82	10.5	M12	26	46	18	6400	5800	1.20

These aluminium sets are available as slotted type to allow adjustment of running clearance. To specify that type use prefix AG28 (only standard length type available in slotted version)

TORQUE RESISTANT BALL BUSHINGS

Torque resistant ball bushings enable torque to be transmitted whilst the bush travels linearly. Our torque-resistant ball bushings are a high precision linear motion system.

The bushing as well as the shaft is equipped with ball guide grooves with special gothic arch profiles. This 4 point contact design offers a considerable load capacity and a high rigidity through slight pre-loading.

High torque loads (via driven shaft or driven bush) and shock resistance are ensured with this particularly compact space-saving design. The optimised load carrying tracks and the polyamide cage enable very smooth motion. The bushing has a lubrication hole.

To retain the lubricant inside the bushing the seals at both ends are designed to fit snugly into the ball grooves. See following pages for the necessary special splined shafting.



See website for full range of sizes

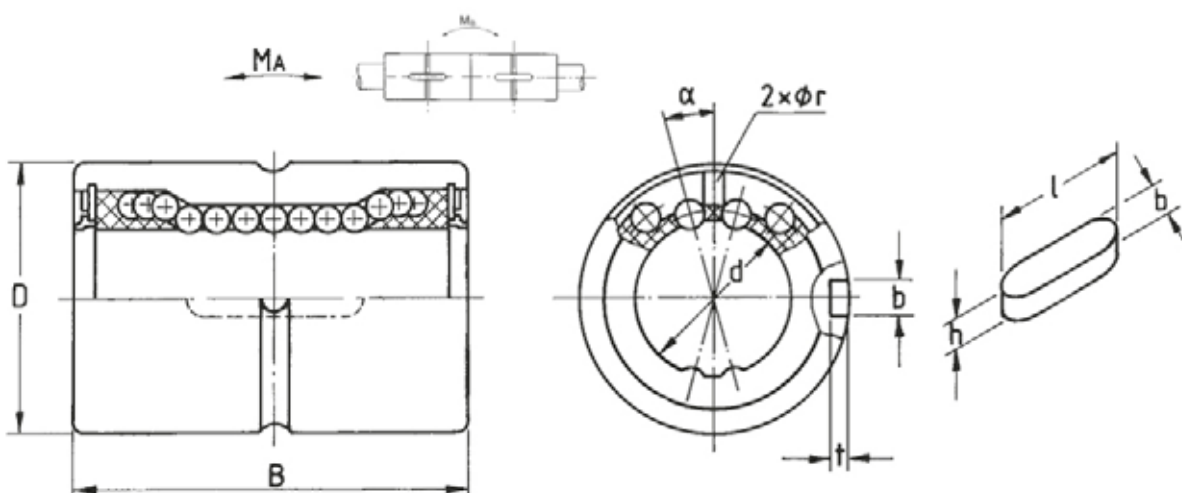

PART										Torque		Load		Moment		Weight (kg)
	h7 d	D	B	H8 b	t	h	l	r	α	Ct (Nm)	C ₀ t (Nm)	C (N)	C ₀ (N)	M _A (Nm)	M _B (Nm)	
SSP4-304	4	10	16	2.0	1.2	2.0	6	-	60	0.7	1.0	860	1220	2.0	10	0.01
SSP4-306	6	14	25	2.5	1.2	2.5	10.5	1	60	1.5	2.4	1220	2280	5.1	40	0.02
SSP4-308	8	16	25	2.5	1.2	2.5	10.5	1.5	60	2.1	3.7	1450	2870	7.4	50	0.02
SSP4-310	10	21	33	3.0	1.5	3.0	13	1.5	60	4.4	8.2	2730	5070	18.0	116	0.05
SSP4-314	13	24	36	3.0	1.5	3.0	15	1.5	25	21	40	2700	4900	13.7	109	0.07
SSP4-316	16	31	50	3.5	2.0	3.5	17.5	2.0	25	60	110	6150	11200	46	299	0.15
SSP4-320	18.2	32	60	4.0	2.5	4.0	26	2.0	16	85	136	8000	11500	64	500	0.20
SSP4-325	23	37	70	5.0	3.0	5.0	33	3.0	16	165	244	12600	16400	106	830	0.22
SSP4-330	28	45	80	7.0	4.0	7.0	41	3.0	16	295	420	19000	23700	185	1470	0.35
SSP4-340	37.4	60	100	10	4.5	8.0	55	4.0	16	650	900	31400	38300	365	2940	0.81
SSP4-350	47	75	112	15	5.0	10	60	4.0	16	1420	3240	47000	75700	710	4400	1.50
SSP4-360	56.5	90	127	18	6.0	11	68	4.0	16	2100	4800	58000	127000	1300	8800	2.50

Tel. 01908 511733

www.euro-bearings.com

EURO-BEARINGS LTD

TORQUE RESISTANT FLANGED BALL BUSHINGS

The torque resistant flanged ball bushings have all the same characteristics as described on the previous page but have the advantage of being easily secured in position via the flange.

Please note shaft diameters 6, 8 & 10 have a flange that has been cut away (see left hand drawing below).

Shaft diameters 14 to 60 have a round flange (right hand drawing below).



See website for full range of sizes

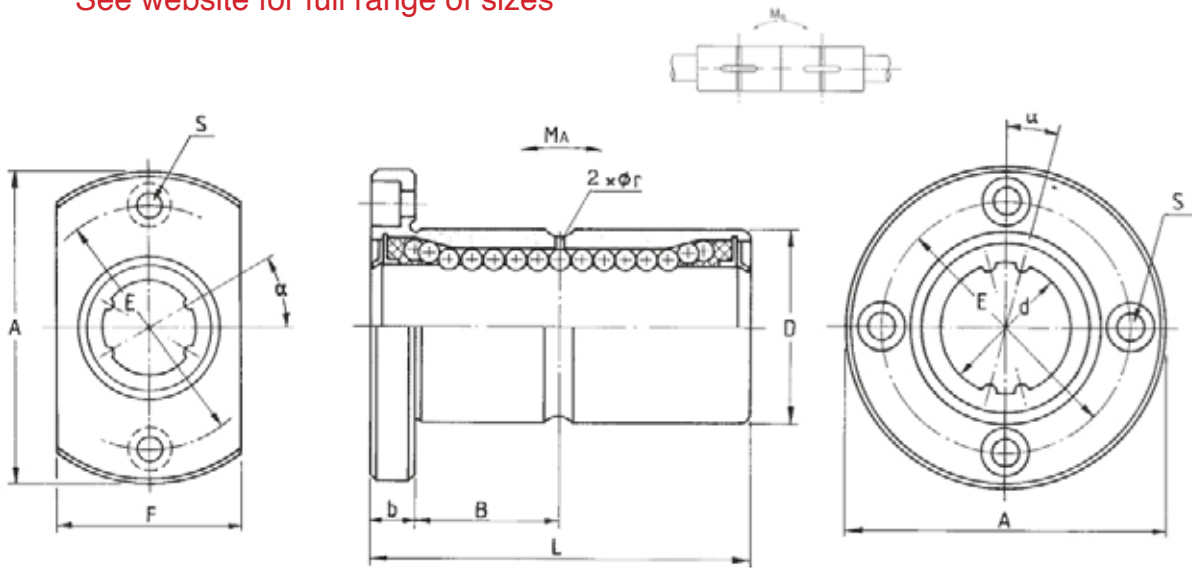

PART	h7 d	D	L	b	A	B	E	F	r	S	α	Torque		Load		Moment		Weight (kg)
												C _T (Nm)	C _{OT} (Nm)	C (kN)	C ₀ (kN)	M _A (Nm)	M _B (Nm)	
SPF4-306	6	14	25	5	30	7.5	22	18	1.0	M3	30	1.5	2.4	1.22	2.28	5.1	40	0.03
SPF4-308	8	16	25	5	32	7.5	24	21	1.5	M3	30	2.1	3.7	1.45	2.87	7.4	50	0.04
SPF4-310	10	21	33	6	42	10.5	32	25	1.5	M4	30	4.4	8.2	2.73	5.07	18	116	0.08
SPF4-314	13	24	36	7	43	11	33	-	1.5	M4	25	21	40	2.70	4.90	13.7	109	0.10
SPF4-316	16	31	50	7	50	18	40	-	2.0	M4	25	60	110	6.15	11.20	46	299	0.20
SPF4-320	18.2	32	60	7	51	23	40	-	2.0	M4	16	85	136	8.00	11.50	64	500	0.22
SPF4-325	23	37	70	9	60	26	47	-	3.0	M5	16	165	244	12.6	16.40	106	830	0.32
SPF4-330	28	45	80	10	70	30	54	-	3.0	M6	16	295	420	19.0	23.7	185	1470	0.51
SPF4-340	37.4	60	100	14	90	36	72	-	4.0	M8	16	650	900	31.4	38.3	365	2940	1.15
SPF4-350	47	75	112	16	113	40	91	-	4.0	M10	16	1420	3240	47.0	75.7	710	4400	2.10
SPF4-360	56.5	90	127	18	129	45.5	107	-	4.0	M10	16	2100	4800	58.0	127.0	1300	8800	3.30

TORQUE RESISTANT SLIDING/ROTATING BUSH

This unit combines:

- The sliding properties of a ball bushing
- The anti-torque of a spline shaft (the shaft is grooved to allow 4 circuits of balls to engage in it)
- the low friction, high load capacity & rigidity of a cross roller bearing

All in one tidy unit !!

Mounting holes are provided in the the faces of the torque resistant bush (PCD values in column e) and the radial bearing (PCD values in column E)

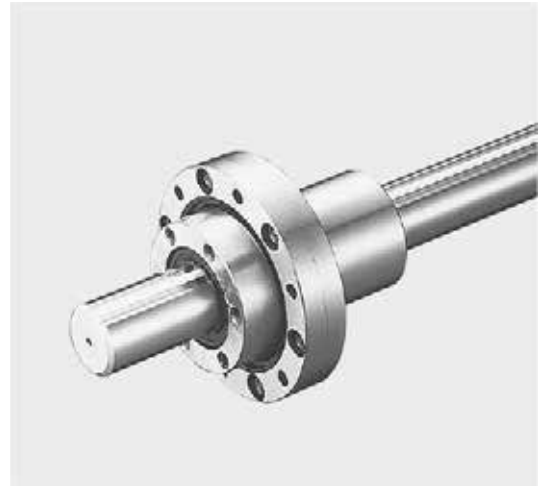

This unit is designed for heavy duty applications.

Examples of applications:

- Rotating Z axis on pick and place machine or robot
- Tool turret on machine tool
- Spooling and winding machines

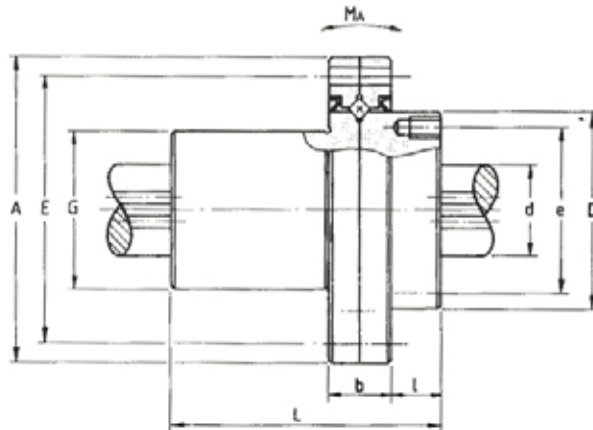
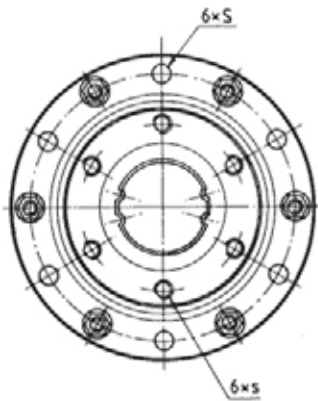

PART	d	D	L	A	b	E	S	G	I	e	S	Torque		Slide Bush Load		Radial Brg Load			Max rpm
												C _T (Nm)	C _{OT} (Nm)	C (kN)	C ₀ (N)	M _A (Nm)	C (kN)	C ₀ (kN)	
SPR1-314	13	29	36	50	9	42	3.4	24	8	24	M3X5	21	39	2.6	4.9	13	3	3.7	1800
SPR1-316	16	36	50	60	11	50	4.5	31	10	30	M4X6	60	110	6.1	11.2	46	5.6	6.7	1500
SPR1-320	18.2	40	60	66	13	56	4.5	34	12	34	M4X7	83	133	7.8	11.3	63	5.9	7.3	1200
SPR1-325	23	50	70	78	16	68	4.5	40	13	42	M5X8	162	239	12.3	16.1	104	9.1	11.5	1000
SPR1-330	28	61	80	100	17	86	6.6	47	17	52	M6X10	289	412	18.6	23.2	181	13.2	18	800
SPR1-340	37.4	76	100	120	20	104	6.6	62	23	64	M6X10	637	882	30.8	37.5	358	22.8	32.3	600
SPR1-350	47	88	112	130	22	114	9.0	75	24	77	M8X13	1390	3180	46.1	74.2	696	27.2	42.1	570
SPR1-360	56.5	102	127	150	25	132	9.0	90	25	90	M8X13	2100	4800	58	127.4	1300	30	48.2	500

SPLINE SHAFTS FOR TORQUE RESISTING BUSHES

Our induction hardened steel spline shafts have four gothic arch profiled grooves to accept the balls from the spline nuts SSP, SPF and SPR.

Two types of spline shafts are available:

Ground Spline Shaft

Type SP..S when high precision and/or high pre-load is required.

Three levels of pre-load are available: Zero, Light (suffix T1) or Medium (suffix T2).

Tolerance for twist is 13μ per 100mm on standard types.

Tolerance for twist is 6μ per 100mm on precision types (P).

Straightness values are given in the table below.

Drawn Spline Shaft

Type SP..C when normal precision level is required.

Available from size 20 to 50 and only without pre-load.

Tolerance for twist is 100μ per 100mm.

Straightness tolerance is 1mm per 1000mm.

The load capacities for drawn spline shafts are only 70% of the values for ground splines shafts.

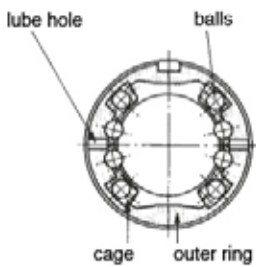
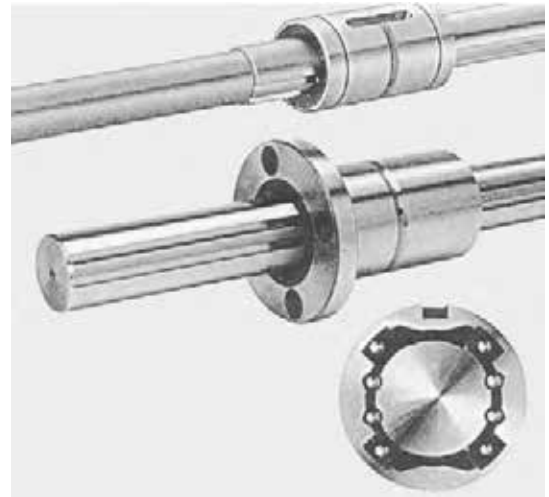

Ball race design

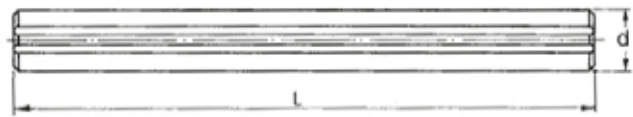

PART	d (h7)	Max length (mm)	Standard Straightness (μ m/m)	Precision Straightness (μ m/m)	No Preload (μ m)		Light Preload T1 (μ m)		Medium Preload T2 (μ m)	
SP04S	4	300	160	110	-2	1	-6	-2	N/A	N/A
SP06S	6	400	160	110	-2	1	-6	-2	N/A	N/A
SP08S	8	500	160	110	-2	1	-6	-2	N/A	N/A
SP10S	10	630	100	65	-3	1	-9	-3	N/A	N/A
SP14S	13	1500	75	50	-3	1	-9	-3	-13	-7
SP16S	16	1500	75	50	-3	1	-9	-3	-13	-7
SP20S	18.2	2000	170	120	-4	2	-12	-4	-20	-12
SP25S	23	2000	170	120	-4	2	-12	-4	-20	-12
SP30S	28	2000	170	120	-4	2	-12	-4	-20	-12
SP40S	37.4	2000	120	80	-6	3	-18	-6	-30	-18
SP50S	47	2000	120	80	-6	3	-18	-6	-30	-18
SP60S	56.5	2000	90	60	-6	3	-18	-6	-30	-18

LINEAR BEARING SHAFTS

These precision steel shafts are manufactured from high grade steel which is induction hardened and centreless ground to ISO tolerance h6. The deviation is less than 0.1mm per metre.

These consistently high quality shafts can be used with ball bushings and other precision engineering projects.

The exact material specifications are:

	Material	(DIN)	Hardness
Solid Shafts	Cf53-56	(1.1214)	60-65 HRC
Hollow Shafts	100 Cr 6	(1.3505)	60-64 HRC
	C 60	(1.0601)	60-65 HRC
Stainless Steel Shafts	X40 Cr13	(1.4034)	51-55 HRC
	X90CrMoV18	(1.4112)	53-58 HRC



Hard chromed shafts on request.

Solid Shafts						
Diameter	Weight	Tolerance	Roundness	Conicity	Depth of Hardness	Max length
mm ()	kg/m	h 6 µm	µm	µm	mm	m
3	0,06	0-8				0,4
4	0,10	0-8			0,4	
5	0,15	0-8				
6	0,22	0-8			0,8-1,1	
6,35 (1/4)	0,25	-13-25	4	6		
8	0,40	0-9				
9,525 (3/8)	0,59	-13-25				
10	0,62	0-9				3-4
12	0,89	0-11				
12,7 (1/2)	0,91	-13-25			1,2-1,5	
14	1,21	0-11				
15	1,39	0-11	5	8		
15,875 (5/8)	1,54	-13-25				
16	1,58	0-11				
18	2,00	0-11				
19,05 (3/4)	2,40	-13-25				
20	2,47	0-13			1,8-2,2	
22	2,98	0-13				
25	3,85	0-13	6	10		
25,4 (1)	3,95	-13-25				
28	4,84	0-13				
30	5,55	0-13				
31,75(1 1/4)	6,20	-13-25				
32	6,31	0-16				
35	7,55	0-16				
36	7,98	0-16				6-7
38,1 (1 1/2)	8,50	-15-28	8	11	2,2-3,2	
40	9,87	0-16				
45	12,45	0-16				
50	15,40	0-16				
50,8 (2)	16,50	-15-33				
60	22,20	0-19				
63,5 (2 1/2)	24,50	-18-38	9	13	2,5-3,5	
70	30,20	0-19				
76,2 (3)	35,50	-20-43				
80	39,50	0-19				
100	61,65	0-22			3,5-4,5	
101,6 (4)	63,65	-30-61	11	15		
Hollow Shafts						
d	d _i					
12	4	0,80	0-11		10	
16	7	1,28	0-11			1,2-1,5
20	12-14	1,26	0-13	5		
25	14,5-15,5	2,37	0-13			1,8-2,2
30	16,5-19,0	3,55	0-13			
40	26-28	5,38	0-15	6	12	2,2-3,2
50	28-35	10,21	0-16			
60	36	15,07	0-19			
80	50-57	20,17	0-19	8	13	2,5-3,5

PROFILED STEEL SHAFTS

These profiled supported steel shafts are the most compact available.

They are available in Aluminium, **WN00-...** up to a length of 3650 mm. The height tolerance is $\pm 20\mu\text{m}$.

They are also available in C45 Steel, **WP11-...**
The maximum length of the shaft is 6000 mm, with 1800 mm sections of steel support bolted underneath.

Both rails are supplied bolted to precision steel shaft with radial holes at spacing 'T' (see table below).

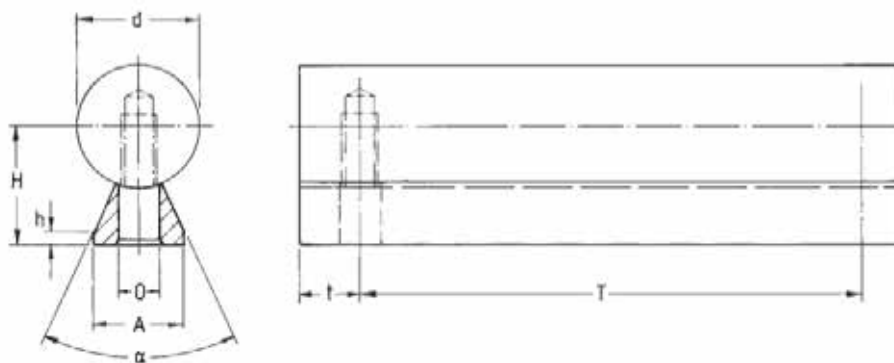

Aluminium	Steel	d	A	H	h	α (deg)	T	t_{\min}	O	Bolt Size	Weight kg/m
WN00-312	-	12	11	14.5	3	50	75	20	4.5	M4	1.1 / -
WN00-316	WP11-316	16	14	18	3	50	75	20	5.5	M5	1.9 / 2.5
WN00-320	WP11-320	20	17	22	3	50	75	20	6.6	M6	2.9 / 3.8
WN00-325	WP11-325	25	21	26	3	50	75	20	9	M8	4.4 / 5.6
WN00-330	WP11-330	30	23	30	3	50	100	20	11	M10	6.2 / 7.6
WN00-340	WP11-340	40	30	39	4	50	100	20	13.5	M12	11 / 13.4
WN00-350	WP11-350	50	35	46	5	50	100	20	15.5	M14	17 / 20.2

ALUMINIUM SHAFT SUPPORT RAILS

These aluminium shaft support rails are for supporting shafts. They can be supplied individually or with shafts (Cf53 hardened & ground or X90CrMov18 stainless steel). Use with open type linear sets (AE37 & TE33) and open type ball bushings.

For continuous support of a shaft these 600mm support rails can be mounted end to end. Alternatively they can be cut into "sleepers" and spaced apart.

Two types of rail are available:
The older type WS50-... with a higher height to shaft centre and the new lower type WU50-...



They are available ex stock unmachined or machined with bolt holes and fixing holes at two standard centres:

t (WU50-1..)

T (WU50-2..)

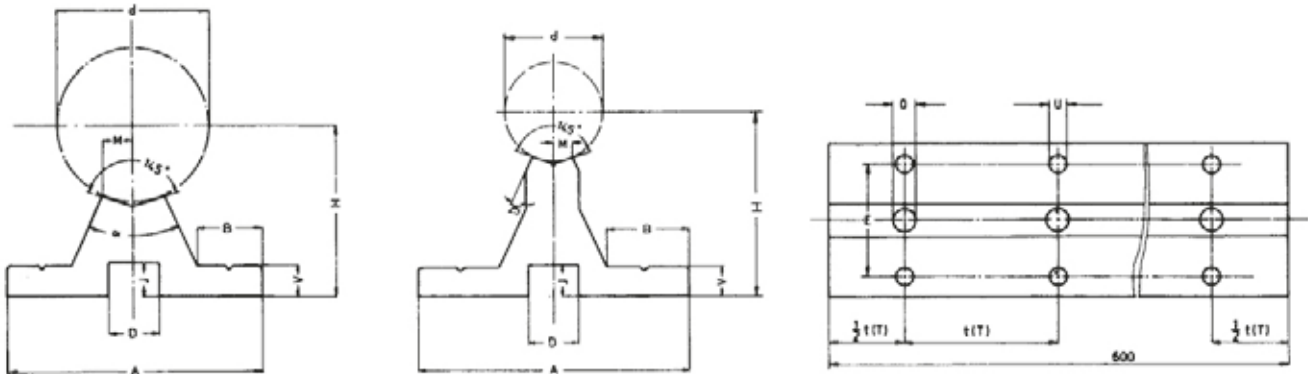

PART	PART	d	H	A	M	B	α	V	D	J	O	Bolt	U	E	t(1) hole spacing	T(2) hole spacing
WU50-012		12	22	40	2.9	12	50	5	8	4.5	4.5	M4X20	4.5	29	75	120
WU50-016		16	26	45	3.5	13	50	5	9.5	5.5	5.5	M5X20	5.5	33	100	150
	WS50-016	16	30	48	3.5	14		5	9.5	5.5	5.5	M5X25	5.5	33	100	150
WU50-020		20	32	52	4.4	14	50	6	11	6.5	6.6	M6X25	6.6	37	100	150
	WS50-020	20	38	56	4	15		6	11	6.5	6.6	M6X30	6.6	37	100	150
WU50-025		25	36	57	5.4	15	50	6	14	8.5	9	M8X30	6.6	42	120	200
	WS50-025	25	42	60	5	15		6	14	8.5	9	M8X35	6.6	42	120	200
WU50-030		30	42	69	5.5	19	50	7	17	8.5	11	M10X35	9	51	150	200
	WS50-030	30	53	74	6	19		8	17	10.5	11	M10X40	9	51	150	200
WU50-040		40	50	73	7.5	17	50	8	17	10.5	11	M10X40	9	55	200	300
	WS50-040	40	60	78	8	19		8	19	12.5	11	M10X45	9	55	200	300
WU50-050		50	60	84	9.5	21	46	9	19	12.5	13	M12X45	11	63	200	300
	WS50-050	50	75	90	10	24		10	19	12.5	13	M12X55	11	63	200	300
WU50-060		60	68	94	12.5	23	46	10	22	14.5	15	M14X50	11	72	300	-
	WS50-060	60	80	100	12	25		12	22	14.5	15	M14X55	11	72	300	-
WU50-080		80	86	116	17	27	46	12	25	16.5	17	M16X60	13	92	300	-

Tel. 01908 511733

www.euro-bearings.com

EURO-BEARINGS LTD

ALUMINIUM SHAFT SUPPORTS - SIDE OPENING

These support rails are very compact and offer high rigidity. They can be mounted either vertically or horizontally.

When mounted horizontally they are especially suitable for the open sided linear sets LE71-... shown on page 33.

There are two types available:

Two rows of fixing holes: WU54-1

One row of fixing holes: WU54-2

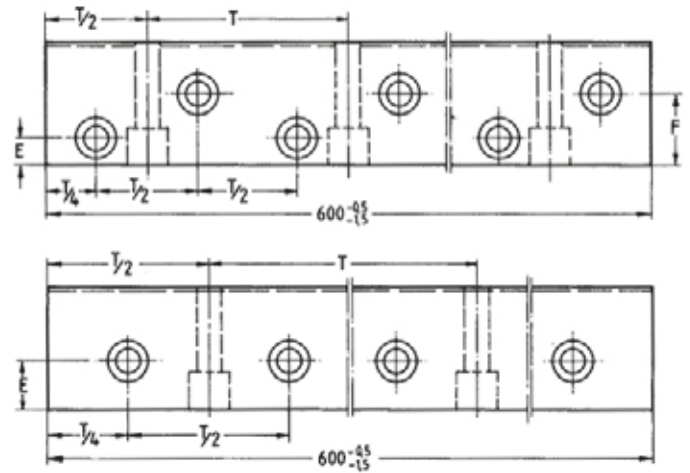
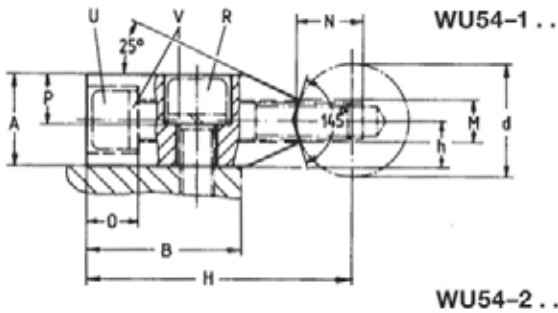

PART	d	h	H	A	M	E	F	T	O	P	B	N	R	U	V
WU54-220	20	7.5	52	15	8.3	15		100	8.5	8.5	30	11	M6X16	M6X45	6
WU54-120	20	7.5	52	15	8.3	8	22	75	8.5	8.5	30	11	M6X16	M6X45	6
WU54-225	25	10	62	20	10.8	18		120	14.0	11	36	15	M8X20	M8X50	8
WU54-125	25	10	62	20	10.8	10	26	75	14.0	11	36	15	M8X20	M8X50	8
WU54-230	30	12.5	72	25	11	21		150	14.5	13.5	42	17	M10X25	M10X60	10
WU54-130	30	12.5	72	25	11	12	30	100	14.5	13.5	42	17	M10X25	M10X60	10
WU54-240	40	15	88	30	15	25		200	17.5	16	50	21	M12X30	M10X70	12 & 10
WU54-140	40	15	88	30	15	12	38	100	17.0	16	50	21	M12X30	M12X70	12
WU54-250	50	17.5	105	35	19	30		200	21.5	19	60	25	M14X35	M12X80	14 & 12
WU54-150	50	17.5	105	35	19	15	45	100	21.0	19	60	25	M14X35	M14X80	14

CAST IRON / ALUMINIUM SHAFT END SUPPORTS

These shaft end support blocks are for clamping and fixing down shaft ends. They have a guaranteed height tolerance of $\pm 15\mu\text{m}$ and are an economic way to mount shafts.

The WB55's are made from spheroidal graphite cast iron, offering high rigidity and high dimensional precision.

The WB56's are made from aluminium with the same tolerances as WB55. However they are less stiff due to the lower modulus of elasticity.

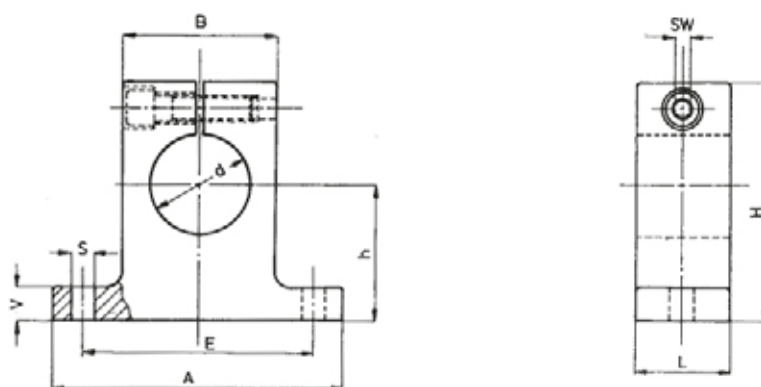

CAST IRON	ALUMINIUM	d	h	H	A	B	L	E	S	V
WB55-008	-	8	15	27	32	16	10	25	4.5	5
WB55-012	WB56-012	12	20	35	42	20	12	32	5.5 / 4.3	5.5
WB55-016	WB56-016	16	25	42	50	26	16	40	5.5 / 4.3	6.5
WB55-020	WB56-020	20	30	50	60	32	20	45	5.5 / 4.3	8
WB55-025	WB56-025	25	35	58	74	38	25	60	6.6 / 5.3	9
WB55-030	WB56-030	30	40	68	84	45	28	68	9.0 / 6.4	10
WB55-040	WB56-040	40	50	86	108	56	32	86	11 / 8.4	12
WB55-050	WB56-050	50	60	100	130	80	40	108	11 / 9.0	14
WB55-060	-	60	75	124	160	100	48	132	13.5	15
WB55-080	-	80	100	160	200	130	60	170	17.5	22

ALUMINIUM SHAFT END SUPPORTS

The WB57 shaft end support blocks are made in aluminium and complement the TE85- and AE35- linear set ranges.

The WB58 shaft end support blocks are made in aluminium and complement the AG27- and AG28- ranges.

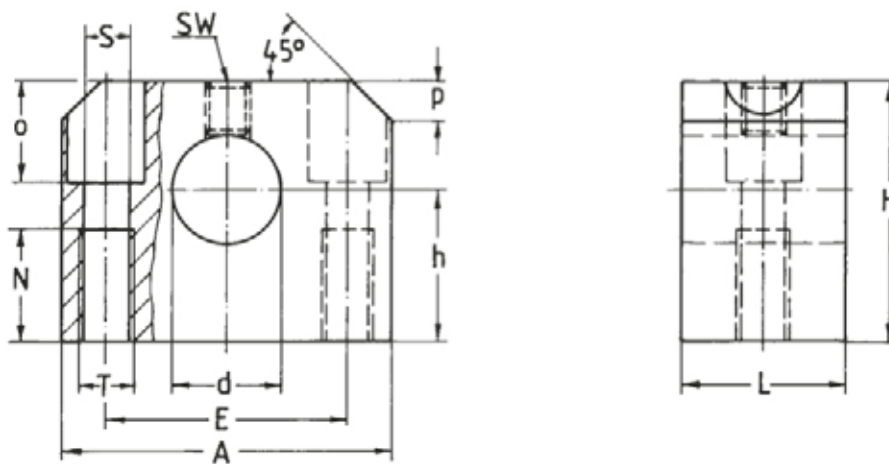

PART	d	h	H	A	L	E	S	T	N	o	p	SW
WB57-012	12	20	35	42	20	30	5.3	M6	13	16	5	3
WB58-012	12	19	33	40	18	27	5.3	M6	13	15	5	3
WB57-016	16	25	42	52	24	38	6.6	M8	18	17	6	3
WB58-016	16	22	38	45	20	32	5.3	M6	13	17	6	3
WB57-020	20	30	50	60	30	42	8.4	M10	22	21	7	4
WB58-020	20	25	45	53	24	39	6.6	M8	18	21	7	4
WB57-025	25	35	60	76	38	56	10.5	M12	26	25	9	5
WB58-025	25	31	54	62	28	44	8.4	M10	22	24	9	5
WB57-030	30	40	70	86	40	64	10.5	M12	26	28	10	5
WB58-030	30	34	60	67	30	49	8.4	M10	22	27	10	5
WB57-040	40	50	90	108	48	82	13.5	M16	34	34	12	6
WB58-040	40	42	76	87	40	66	10.5	M12	26	35	12	6
WB57-050	50	60	105	130	58	100	17.5	M20	43	40	13	6
WB58-050	50	50	92	103	50	80	13.5	M16	34	43	13	6

FLANGED SHAFT END SUPPORTS

These flanged shaft end support blocks are made from spheroidal graphite cast iron. They are designed to secure linear bearing shafts between bulkheads or other vertical surfaces. They are shaped to enable easy alignment against the mounting surface.

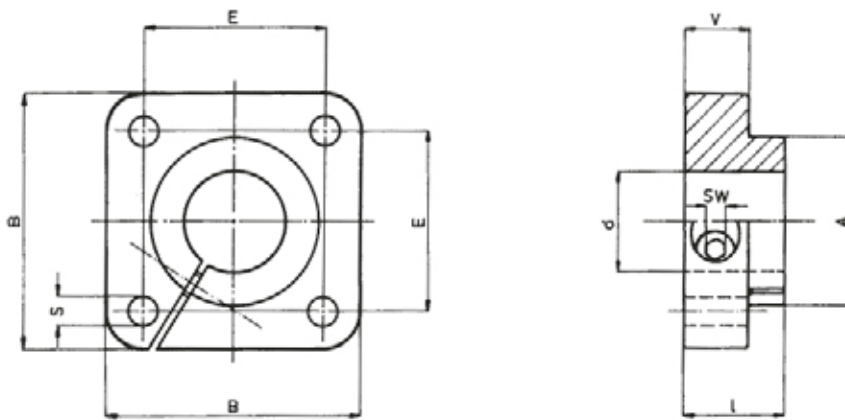

PART	d	B	I	A	E	S	V	SW
FH56-012	12	42	20	23	30	5.5	12	4
FH56-016	16	50	20	27	35	5.5	12	4
FH56-020	20	54	23	33	38	6.6	14	5
FH56-025	25	60	25	42	42	6.6	16	5
FH56-030	30	76	30	49	54	9	19	6
FH56-040	40	96	40	65	68	11	26	8
FH56-050	50	106	50	75	75	11	36	8

Tel. 01908 511733

www.euro-bearings.com

EURO-BEARINGS LTD

STAINLESS STEEL SHAFT END SUPPORTS

These shaft supports are made from highly corrosion & acid resistant chrome-nickel steel. The WB59 supports are mounted from below, whilst the FB59 blocks are bolted from the side.

These supports are particularly suitable for the chemical, pharmaceutical & food industries.

Should you want to attach the supports from above, the bolt holes in WB59 can be drilled all the way through.

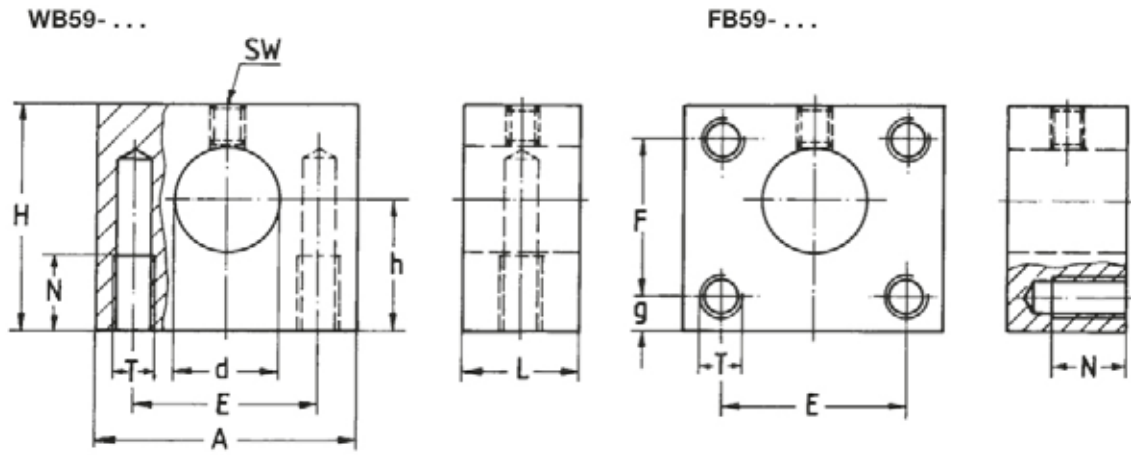
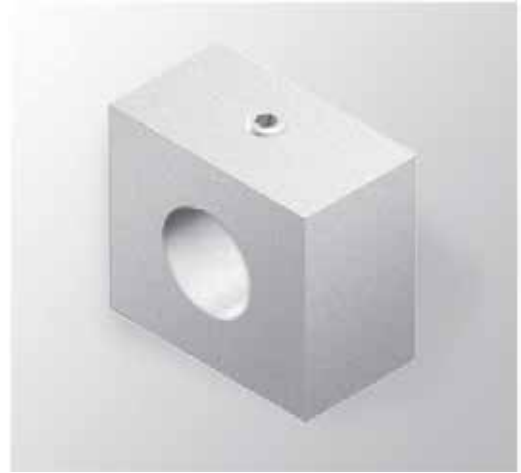

Part Number	d	h	H	A	L	E	F	g	N	T	SW
WB59-512	12	19	33	40	18	27			12	M6	3
FB59-512	12	19	33	40	18	27	22	6	12	M6	3
WB59-516	16	22	38	45	20	32			13	M6	3
FB59-516	16	22	38	45	20	32	26	6	13	M6	3
WB59-520	20	26	46	53	24	39			15	M8	4
FB59-520	20	26	46	53	24	39	30	8	15	M8	4
WB59-525	25	31	54	62	28	44			18	M10	4
FB59-525	25	31	54	62	28	44	38	8	18	M10	4
WB59-530	30	36	62	67	30	49			22	M10	4
FB59-530	30	36	62	67	30	49	42	10	22	M10	4
WB59-540	40	46	80	87	40	66			22	M12	5
FB59-540	40	46	80	87	40	66	60	10	22	M12	5

SEALS

These seal rings are designed to ensure they locate perfectly in the housing bore without any other retaining facility (interference fit).

A number of factors have to be considered when selecting supplementary seals, for instance, the arrangement, design or available space. Furthermore, seals increase friction. This V-section seal consists of two wipers and performs two purposes. The inner wiper retains the lubricant in the bushing and the outer wiper protects the ball bushing against the ingress of particles.



Bellows type covers should be used if it is envisaged that quantities of dirt particles will be evident in the operating environment.

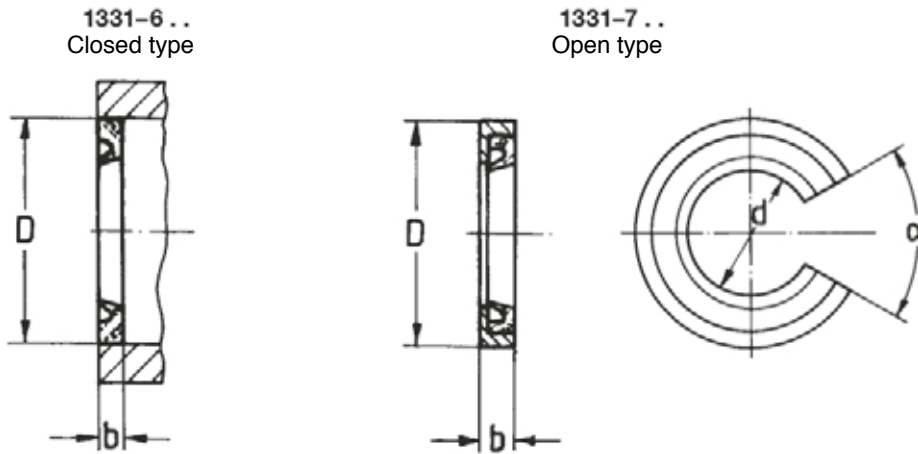

PART		d	D	b	α
CLOSED	OPEN				
1331-612		12	22	3	
	1331-712	12	22	5	68
1331-616		16	26	3	
	1331-716	16	26	5	
1331-620		20	32	4	
	1331-720	20	32	6	56
1331-625		25	40	4	
	1331-725	25	40	6	58
1331-630		30	47	5	
	1331-730	30	47	7	58
1331-640		40	62	5	
	1331-740	40	62	7	57
1331-650		50	75	6	
	1331-750	50	75	11	55

COMPLETE SLIDING SYSTEM (CLOSED)

The major benefit of this quad housing is that it is much easier to set up than using multiple single housings or a torque resistant ball bushing. Each quad housing contains four ball bushings. The shafts are machined to order and can be supplied to any length (limited only by permissible deflection)

Two aluminium shaft end support blocks hold the shafts parallel and clamped (when bolted down) in position. The assembly can be arranged so that the table is fixed with the shaft ends free, or the shaft ends can be fixed so that the table is free. The ball bushings in the housing unit are sealed as standard.

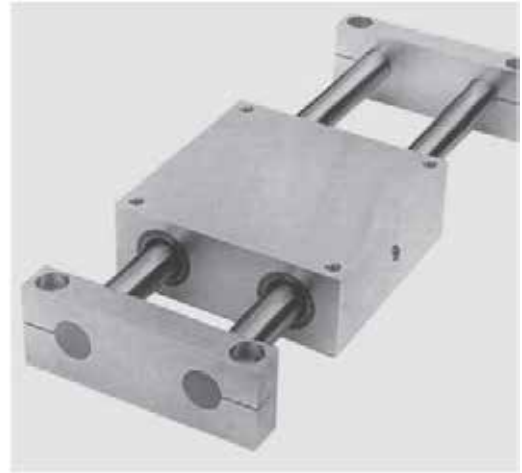

For operating temperatures > 80° C (where the seals will be damaged) specify the all steel unsealed ball bushing type NB00- using part number VB40-0..

If you require corrosion resistant ball bushings these can be fitted – please specify VB40-5.. (where ..= shaft diameter).

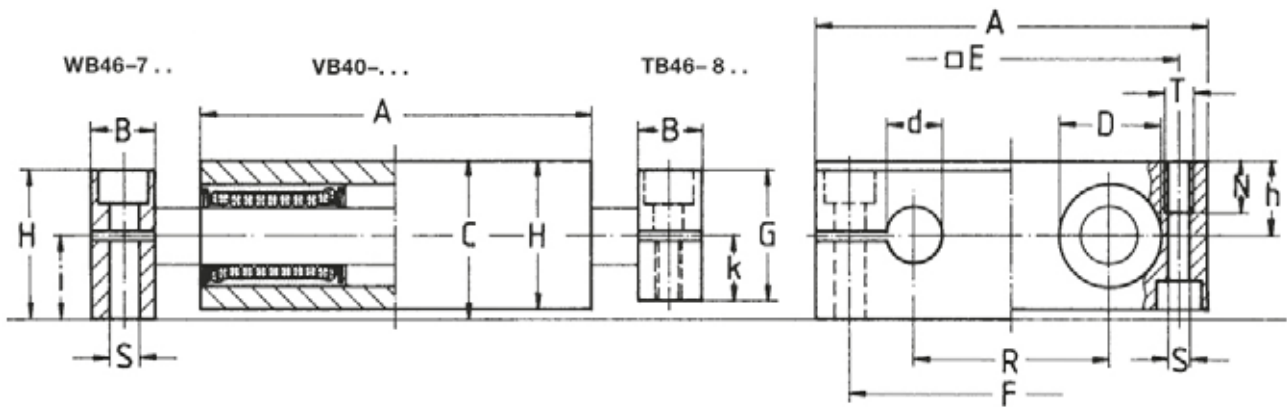

SHAFT SUPPORTS		HOUSING	d	A	H	h	C	D	E	R	i	B	S	T	N	k	F	G	Load C (kN)	Load C ₀ (kN)
Fixed End	Free End																			
		VB40-208	8	65	23	15.5	24	16	55	32		4.3	M5	11					0.9	1.2
WB46-708	TB46-808		8	65	23					32	12.5	12	5.5	M5		11	52	22		
		VB40-212	12	85	32	16	34	22	73	42			5.3	M6	13				1.3	2
WB46-712	TB46-812		12	85	32					42	18	14	6.6	M6		14	70	28		
		VB40-216	16	100	36	18	38	26	88	54			5.3	M6	13				1.5	2.3
WB46-716	TB46-816		16	100	36					54	20	18	9	M8		16	82	32		
		VB40-220	20	130	46	23	48	32	115	72			6.4	M8	18				3.2	4.9
WB46-720	TB46-820		20	130	46					72	25	20	11	M10		21	108	42		
		VB40-225	25	160	56	28	58	40	140	88			8.4	M10	22				5.6	8.7
WB46-725	TB46-825		25	160	56					88	30	25	13.5	M12		26	132	52		
		VB40-230	30	180	64	32	67	47	158	96			10.5	M12	26				6.3	10
WB46-730	TB46-830		30	180	64					96	35	25	13.5	M12		29	150	58		
		VB40-240	40	230	80	40	84	62	202	122			13.5	M16	34				11	15
WB46-740	TB46-840		40	230	80					122	44	30	17.5	M16		36	190	72		
		VB40-250	50	280	96	48	100	75	250	152			13.5	M16	34				16.5	26
WB46-750	TB46-850		50	280	96					152	52	30	17.5	M16		44	240	88		

COMPLETE SLIDING SYSTEM (OPEN)

The open type quad housing is more cost effective and avoids the hassle of precisely adjusting four single housings or two tandem units.

The user can choose between all the shaft support rails shown in this catalogue i.e. WU50, WS50, WU54, WN00 & WP11.

The steel shafts can be machined to the customer's requirements and if necessary can be joined to exceed the maximum length.

The housing contains four fully sealed open type ball bushings.

For temperatures $> 80^{\circ}\text{C}$ specify the all steel unsealed open type ball bushings NB30- with part number VB45-0..

To order the unit with stainless steel linear bearings specify VB45-5.. (where .. = shaft diameter).

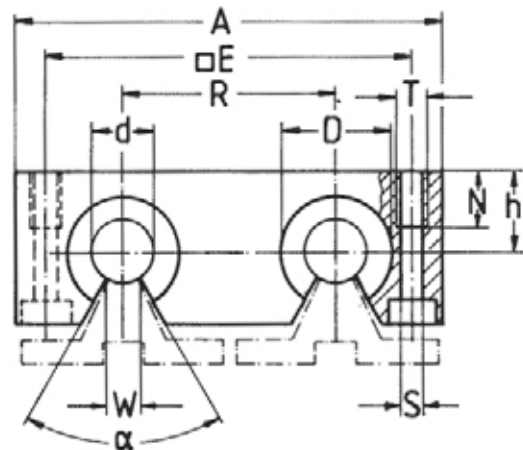
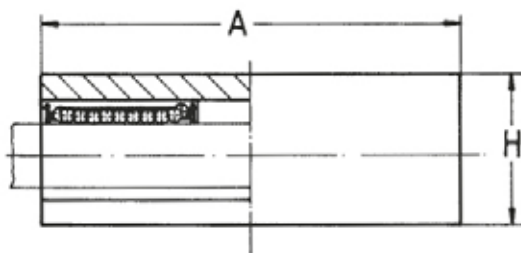

PART	d	A	H	h	D	E	R	S	T	N	W	α	Load C (kN)	Load C ₀ (kN)
VB45-212	12	85	30	18	22	73	42	5.3	M6	13	7.5	78	1.5	2.2
VB45-216	16	100	35	22	26	88	54	5.3	M6	13	10	78	1.8	2.7
VB45-220	20	130	42	25	32	115	72	6.4	M8	18	10	60	3.3	5
VB45-225	25	160	51	30	40	140	88	8.4	M10	22	12.5	60	5.8	9
VB45-230	30	180	60	35	47	158	96	10.5	M12	26	12.5	50	6.3	10.4
VB45-240	40	230	77	45	62	202	122	13.5	M16	34	16.8	50	10.9	15.6
VB45-250	50	280	93	55	75	250	152	13.5	M16	34	21	50	16.8	25.9



Vee Bearings
& Rails



Combined Roller
Bearings & Rails



**NEED TECHNICAL ADVICE?
Contact Gerry, Kate or Matt**

Tel. 01908 511733
email: sales@euro-bearings.com
www.euro-bearings.com

EURO-BEARINGS LTD
29-31 Lodge Farm Business Centre
Wolverton Road
Castlethorpe
Milton Keynes
MK19 7ES