



## TTL Input Module

Cat. No. 1771-IGD

### To The Installer

Use this document as a guide when installing the catalog number 1771-IGD TTL input module.

<b>For information on:</b>	<b>See page</b>
↓ Important User Information	1
↓ Preinstallation Considerations	3
↓ Calculate Power Requirements	4
↓ Initial Handling	4
↓ Set the Logic Level	5
↓ Key the Backplane Connector	6
↓ Install the Module and Field Wiring Arm	7
↓ Connect Wiring to the Output Module	8
↓ Replacing the Fuse	11

<b>For this reference information</b>	<b>See page</b>
⇒ Interpreting the Status Indicators	11
⇒ Specifications	11

### Important User Information

Because of the variety of uses for the products described in this publication, those responsible for the application and use of these products must satisfy themselves that all necessary steps have been taken to assure that each application and use meets all performance and safety requirements, including any applicable laws, regulations, codes and standards. In no event will Rockwell Automation be responsible or liable for indirect or consequential damage resulting from the use or application of these products.

Any illustrations, charts, sample programs, and layout examples shown in this publication are intended solely for purposes of example. Since there are many variables and requirements associated with any particular installation, Rockwell Automation does not assume responsibility or liability (to include intellectual property liability) for actual use based upon the examples shown in this publication.

Allen–Bradley publication SGI–1.1, Safety Guidelines for Application, Installation, and Maintenance of Solid–State Control (available from your local Rockwell Automation office), describes some important differences between solid–state equipment and electromechanical devices that should be taken into consideration when applying products such as those described in this publication.

Reproduction of the contents of this copyrighted publication, in whole or part, without written permission of Rockwell Automation, is prohibited.

Throughout this publication, notes may be used to make you aware of safety considerations. The following annotations and their accompanying statements help you to identify a potential hazard, avoid a potential hazard, and recognize the consequences of a potential hazard.

---

**WARNING**

Identifies information about practices or circumstances that can cause an explosion in a hazardous environment, which may lead to personal injury or death, property damage, or economic loss.

---

---

**ATTENTION**

Identifies information about practices or circumstances that may lead to personal injury or death, property damage, or economic loss.

---

---

**IMPORTANT**

Identifies information that is critical for successful application and understanding of the product.

---

**ATTENTION****Environment and Enclosure**

This equipment is intended for use in a Pollution Degree 2 industrial environment, in overvoltage Category II applications (as defined in IEC publication 60664-1), at altitudes up to 2000 meters without derating.

This equipment is considered Group 1, Class A industrial equipment according to IEC/CISPR Publication 11. Without appropriate precautions, there may be potential difficulties ensuring electromagnetic compatibility in other environments due to conducted as well as radiated disturbance.

This equipment is supplied as “open type” equipment. It must be mounted within an enclosure that is suitably designed for those specific environmental conditions that will be present, and appropriately designed to prevent personal injury resulting from accessibility to live parts. The interior of the enclosure must be accessible only by the use of a tool. Subsequent sections of this publication may contain additional information regarding specific enclosure type ratings that are required to comply with certain product safety certifications.

See NEMA Standards publication 250 and IEC publication 60529, as applicable, for explanations of the degrees of protection provided by different types of enclosures. Also, see the appropriate sections in this publication, as well as the Allen-Bradley publication 1770-4.1, (“Industrial Automation Wiring and Grounding Guidelines”), for additional installation requirements pertaining to this equipment.

**Pre-installation Considerations**

You can use this module in a Series A or B 1771-A1B, -A2B, -A3B, -A3B1, and -A4B chassis. The module is also compatible in a 1771-AM1 or -AM2 I/O chassis.

You can use any TTL device that meets the output logic level specification of -0.2V dc to +0.8V dc (low), and 2.0V dc to 5.25V dc (high).

This module contains input filtering to limit the effects of voltage transients caused by contact bounce and/or radiated electrical noise. The delay due to filtering is less than 1ms.

For maximum noise immunity, the output of the TTL device should have a pull-up resistor of 1k ohm (typical). Add an external pull-up resistor to the output terminals of the device, if necessary. If you add a pull-up resistor, be sure the TTL device maintains the low state requirement of -0.2V dc to +0.8V dc with the increased load.

## Calculate Power Requirements

The TTL module requires power from two sources: the I/O chassis backplane, and a +5V dc Class 2 power supply that you provide for transmission of TTL signals.

### Backplane

The TTL module receives its power through the 1771 I/O chassis backplane from the chassis power supply. The module requires 130mA from the output of this supply. Add this to the requirements of all other modules in the I/O chassis to prevent overloading the chassis backplane and/or backplane power supply.

### Customer Supply

You must provide a separate +5(+0.25)V dc Class 2 power supply for the TTL inputs of the module and for your TTL output devices. Your module requires 380mA from the output of your supply. Ripple should not exceed 50mV peak to peak.

## Initial Handling

The TTL input module is shipped in static-safe packaging to guard against electrostatic discharge damage. Observe the following precautions when handling the module.

---

**ATTENTION****Preventing Electrostatic Discharge**

This equipment is sensitive to electrostatic discharge, which can cause internal damage and affect normal operation. Follow these guidelines when you handle this equipment:

- Touch a grounded object to discharge potential static.
  - Wear an approved grounding wriststrap.
  - Do not touch connectors or pins on component boards.
  - Do not touch circuit components inside the equipment.
  - If available, use a static-safe workstation.
  - When not in use, keep modules in appropriate static-safe packaging.
-

## Setting the Logic Level

Your module is preset to the positive-logic level. Use the following table to choose between the two logic levels:

If you choose:	Then:	Jumper Position
HIGH = TRUE logic (positive)	2.0 to 5.25V dc corresponds to logic "1" (on)	Toward rear of module
LOW = TRUE logic (negative)	-0.2 to 0.8V dc corresponds to logic "1" (on)	Toward front of module

Note: Selecting positive logic automatically enables the HIGH (positive logic) indicator.

You select high-true or low-true using the jumper accessible through a slot at the top of the module.

1. Locate the jumper in the slot at the top edge of the module.
2. Use tweezers to position the jumper as required for your application.

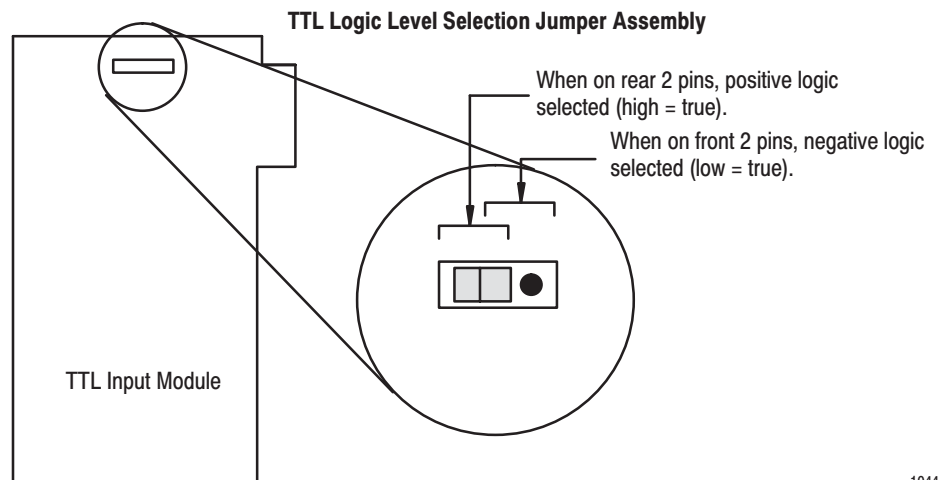

1044

## Key the Backplane Connector

### ATTENTION



A module inserted into a wrong slot could be damaged by improper voltages connected through the wiring arm. Use keying bands to prevent damage to the module.

Place your module in any slot in the chassis except the leftmost slot, which is reserved for processors or adapters.

### ATTENTION



Observe the following precautions when inserting or removing keys:

- insert or remove keys with your fingers
- make sure that key placement is correct

Incorrect keying or the use of a tool can result in damage to the backplane connector and possible system faults.

Position the keying bands in the backplane connectors to correspond to the key slots on the module.

Place the keying bands:  
 - between 16 and 18  
 - between 24 and 26

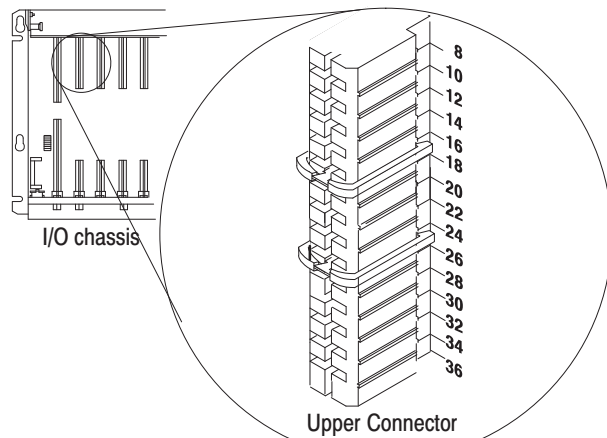

You can change the position of these bands if subsequent system design and rewiring makes insertion of a different type of module necessary.

11022-I

## Install the Module and Field Wiring Arm

### ATTENTION



Remove power from the 1771 I/O chassis backplane and field wiring arm before removing or installing an I/O module.

- Failure to remove power from the backplane or wiring arm could cause module damage, degradation of performance, or injury.
- Failure to remove power from the backplane could cause injury or equipment damage due to possible unexpected operation.

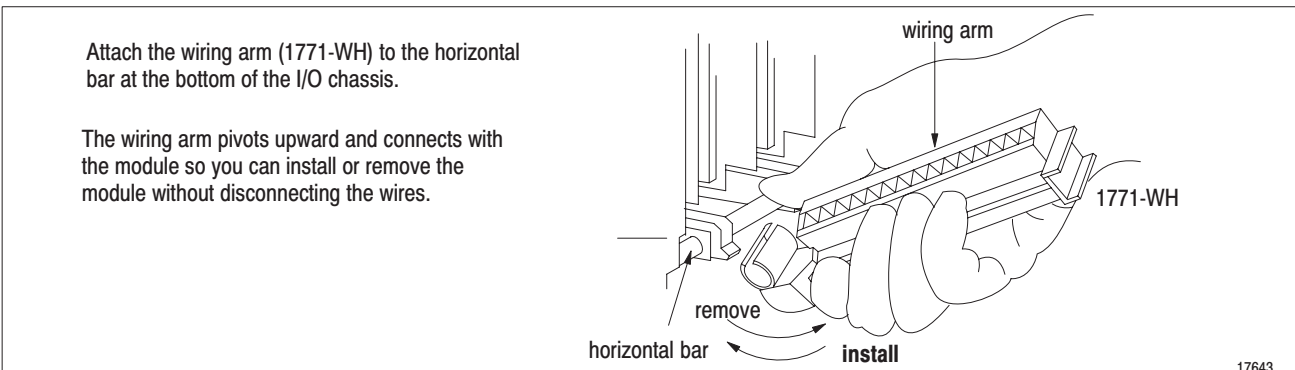
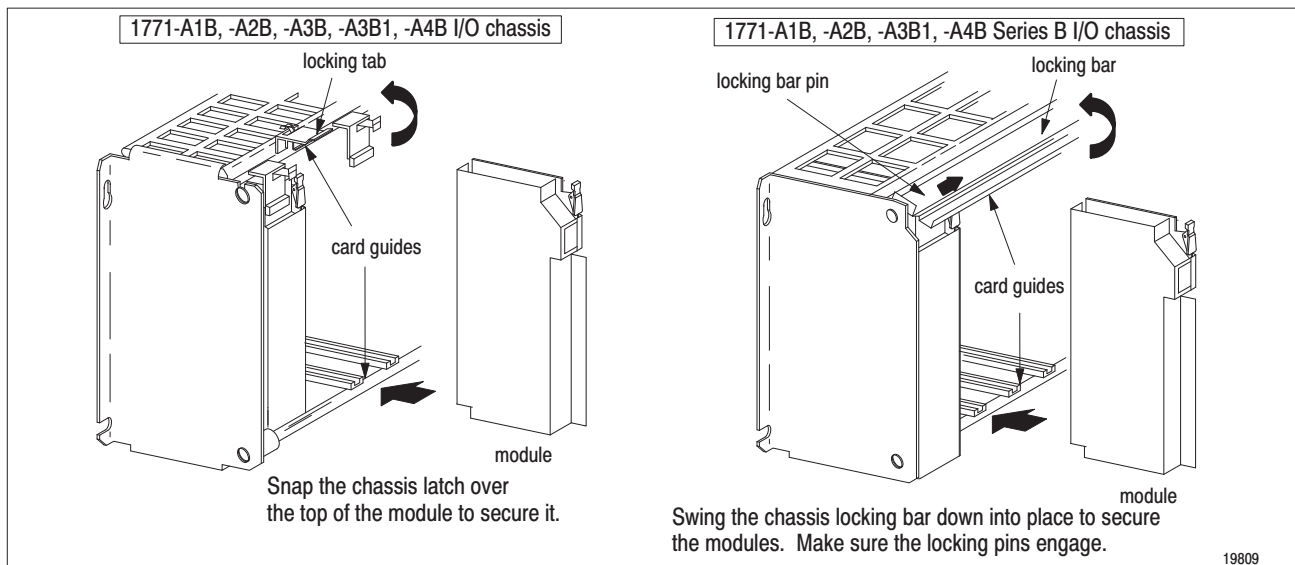

The 1771-IGD module is a modular component of the 1771 I/O system requiring a properly installed system chassis. Refer to publication 1771-IN075 for detailed information on acceptable chassis, proper installation and grounding requirements. Limit the maximum adjacent slot power dissipation to 10W maximum.

## Connect Wiring to the Input Module

### ATTENTION



Remove power from the 1771 I/O chassis backplane and field wiring arm before removing or installing an I/O module.

- Failure to remove power from the backplane or wiring arm could cause module damage, degradation of performance, or injury.
- Failure to remove power from the backplane could cause injury or equipment damage due to possible unexpected operation.

Connect wiring to the input module using the field wiring arm (cat. no. 1771-WH) shipped with the module (shown in the connection diagram below). Make your connections as follows:

1. Attach the field wiring arm to the pivot bar on the bottom of the I/O chassis.
2. Pivot the wiring arm upward and push it into the module until the wiring arm clicks into position. The field wiring arm is designed to let you install and remove the module without disconnecting the wires.

### ATTENTION



Do not apply ac or reverse dc voltage to module terminals. Circuitry at the input of module may be damaged.

3. Separate the shielded cables from wiring that radiates electrical noise. Refer to category 2, low power dc I/O lines, in publication 1770-4.1, "Programmable Controller Wiring and Grounding Guidelines".
4. Prepare the cable for grounding by doing the following:

Remove a length of cable jacket from the Belden 8761 cable.



Belden 8761 Cable

Pull the foil shield and bare drain wire from the insulated wires.

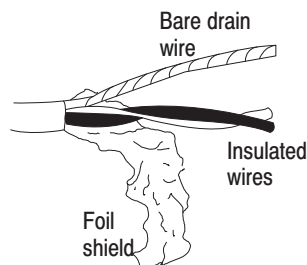

Bare drain wire

Insulated wires

Foil shield

Twist the foil shield and drain wire together to form a single strand.



Attach a ground lug.



5. Ground the single strand (at the ground lug end) to the grounding stud on the I/O chassis or by using single-point grounding.

20104



**Chassis Ground**

When you connect grounding conductors to the I/O chassis grounding stud, place a star washer under the first lug, then place a nut with captive lock washer on top of each ground lug. Torque the nut with captive washer to 18(+3) pound-inches.

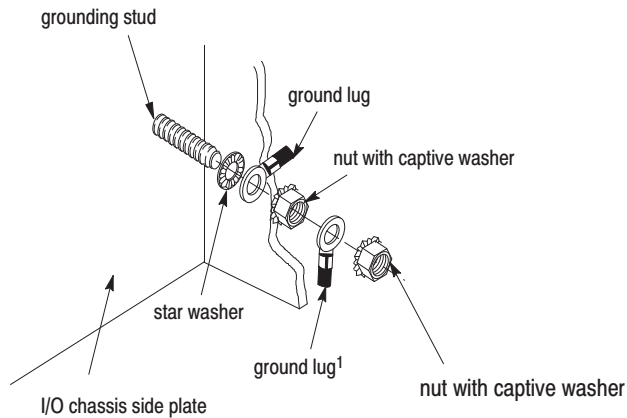

<sup>1</sup>Use the cup washer if crimp-on lugs are not used.

19480

**Single-point Grounding****ATTENTION**

Use single-point grounding for extended-local I/O system. The systems must be grounded properly for proper performance.

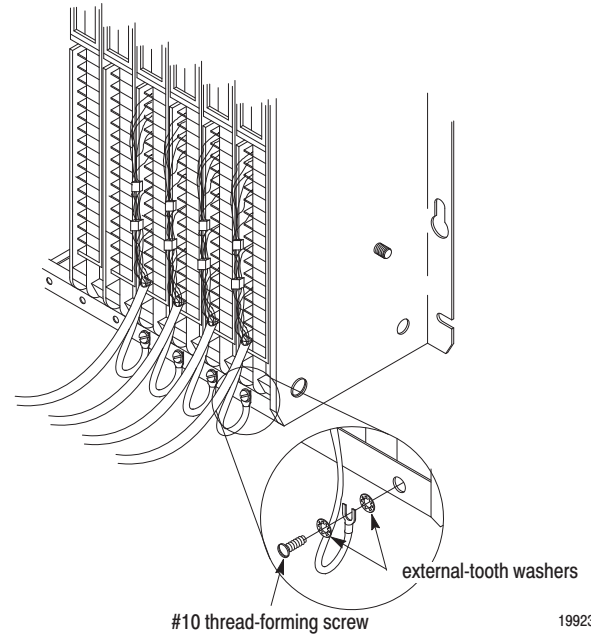

19923

6. You must connect both ends of the insulated signal return wire in each transmission cable as follows:

- connect one end to the dc common terminal of your +5V dc Class 2 power supply
- connect the other end to the dc common terminal of the field wiring arm

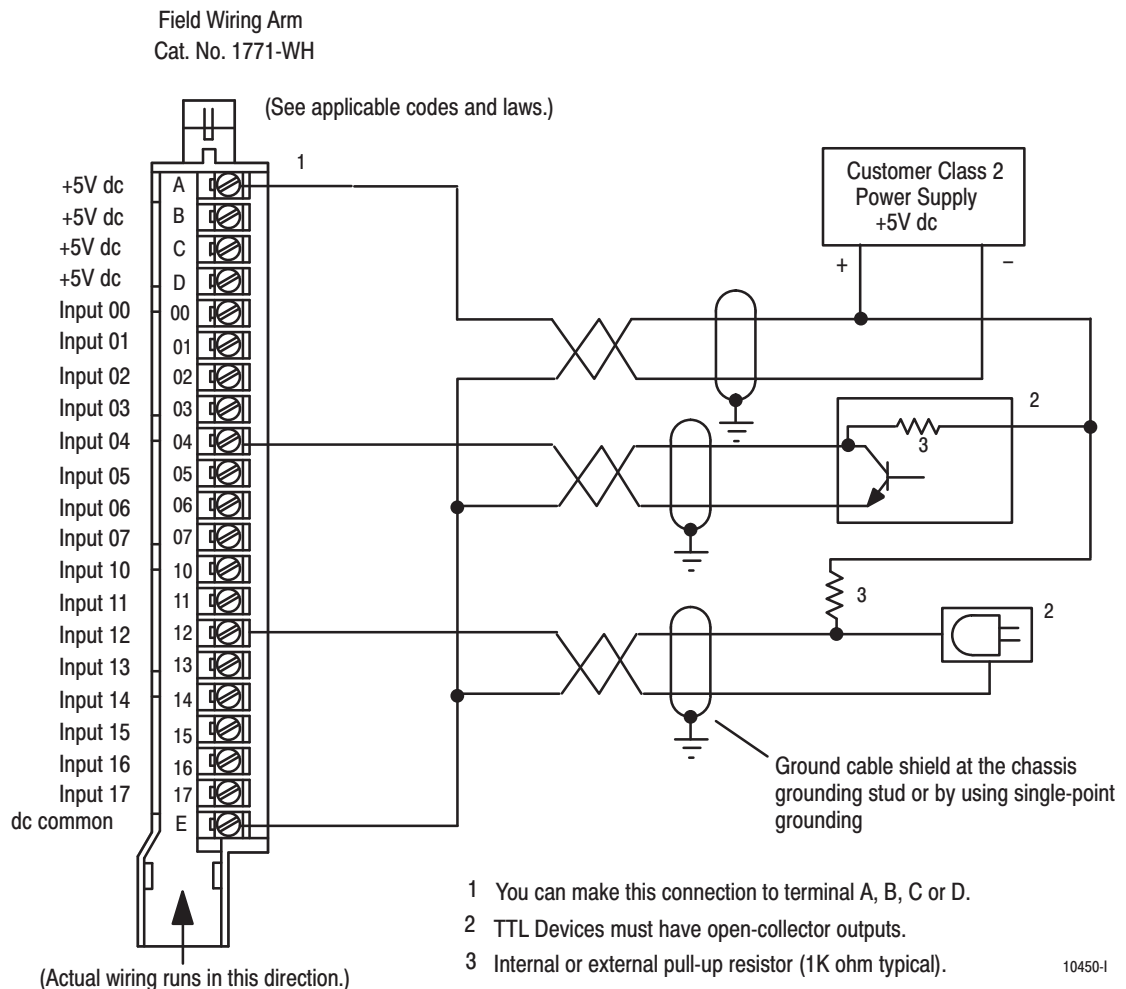

Do not exceed the specified isolation voltage when using multiple power sources.

7. Connect TTL output devices using Belden 8761 shielded cable as shown in the connection diagram. Do not exceed 50 cable feet for any output device. Connect the insulated wires to their respective terminals on the field wiring arm.

### Driving Inputs with Outputs

Input terminals of the TTL input module (cat. no. 1771-IGD) may be directly driven by the outputs of a TTL output module (cat. no. 1771-OGD). Connect the cable shield between modules at one end only.

## Interpreting the Status Indicators

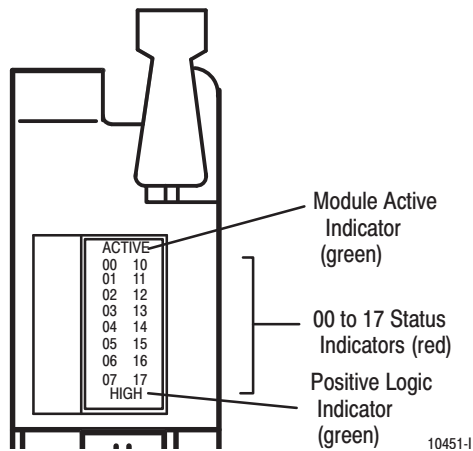

The front panel of your module contains 18 status indicators. The green top indicator is labeled “ACTIVE.” This indicator is on when the fuse is good. The green bottom indicator, when on, indicates you selected high-true logic. When off, it indicates you selected low-true logic.

Each of the 16 red status indicators light when their corresponding input terminal senses TTL voltages in the true state.

## Replacing the Fuse

To replace a blown fuse, proceed as follows:

### ATTENTION



Remove power from the 1771 I/O chassis backplane and field wiring arm before removing or installing an I/O module.

- Failure to remove power from the backplane or wiring arm could cause module damage, degradation of performance, or injury.
- Failure to remove power from the backplane could cause injury or equipment damage due to possible unexpected operation.

1. Turn off power to the chassis.
2. Remove the module from the I/O chassis.
3. Remove the blown fuse from the fuse holder (accessible through the slot in the side cover), and replace with a 0.5A, 250V normal blow fuse.
4. Reinsert module into the I/O chassis.
5. Turn on power to the chassis.

## Specifications

Inputs per Module	16
Module Location	1771-A1B thru-A4B or later I/O chassis, 1771-AM1, and -AM2 I/O chassis.
Input Voltage Rating	HIGH = TRUE LOW = TRUE
	ON: 2.0 to 5.25V dc OFF: -0.2 to +0.8V dc ON: -0.2 to +0.8V dc OFF: 2.0 to 5.25V dc
Customer Current Sink Requirements	7mA maximum (source per input) 0.8mA maximum (sink per input)
Customer Supply Voltage	5.0V dc (+0.25V) Class 2 50mV peak-to-peak ripple max.

Specifications continued on next page.

Customer Supply Current per Module	380mA max.
Input Signal Delay	Less than 1ms
Power Dissipation	2.7 Watts (max.); 0.4 Watts (min.)
Thermal Dissipation	9.2 BTU/hr (max.); 1.4 BTU/hr (min.)
Backplane Voltage/Current	5V dc, 130mA max.
Isolation Voltage	Tested to 600V dc for 1s
Environmental Conditions	
Operating Temperature	IEC 60068-2-1 (Test Ad, Operating Cold) IEC 60068-2-2 (Test Bd, Operating Dry Heat) IEC 60068-2-14 (Test Nb, Operating Thermal Shock) 32 to 131°F (0° to 60°C)
Storage Temperature	IEC 60068-2-1 (Test Ab, Unpackaged, Nonoperating Cold) IEC 60068-2-2 (Test Bb, Unpackaged, Nonoperating Dry Heat) IEC 60068-2-14 (Test Na, Unpackaged, Nonoperating Thermal Shock) -40 to 185°F (-40 to 85°C)
Relative Humidity	IEC 60068-2-30 (Test Db, Unpackaged, Nonoperating Damp Heat) 5 to 95%, noncondensing
Enclosure Type Rating	None (open-style)
Keying	Between 16 and 18 Between 24 and 26
Fuse	0.5A 250V normal blow
Conductors	Wire Size Cable Category
	14 AWG (2.5mm <sup>2</sup> ) stranded copper rated at 60°C or greater 3/64 inch (1.2mm) insulation (max) Shielded (Belden 8761) 2 <sup>1</sup>
Field Wiring Arm	Catalog Number 1771-WH
Wiring Arm Screw Torque	9 pound-inches (1.0Nm)
Certifications (when product is marked)	UL UL Listed Industrial Control Equipment CSA CSA Certified Process Control Equipment CE <sup>2</sup> European Union 89/336/EEC EMC Directive, compliant with: EN 50082-2, Industrial Immunity EN 61236, Meas./Control/Lab., Industrial Requirements EN 61000-6-2, Industrial Immunity EN 61000-6-4, Industrial Emissions C-Tick <sup>2</sup> Australian Radiocommunications Act, compliant with: AS/NZS 2064, Industrial Emissions

<sup>1</sup> You use this conductor category information for planning conductor routing as described in publication 1770-4.1, Industrial Automation Wiring and Grounding Guidelines.

<sup>2</sup> See the Product Certification link at [www.ab.com](http://www.ab.com) for Declarations of Conformity, Certificates and other certification details

[www.rockwellautomation.com](http://www.rockwellautomation.com)

### Power, Control and Information Solutions Headquarters

Americas: Rockwell Automation, 1201 South Second Street, Milwaukee, WI 53204-2496 USA, Tel: (1) 414.382.2000, Fax: (1) 414.382.4444

Europe/Middle East/Africa: Rockwell Automation, Vorstlaan/Boulevard du Souverain 36, 1170 Brussels, Belgium, Tel: (32) 2 663 0600, Fax: (32) 2 663 0640

Asia Pacific: Rockwell Automation, Level 14, Core F, Cyberport 3, 100 Cyberport Road, Hong Kong, Tel: (852) 2887 4788, Fax: (852) 2508 1846