

CombiTac uniq Main catalog

CombiTac

EN



STÄUBLI ELECTRICAL CONNECTORS

Connections for Life



Stäubli, as the international technology leader, offers innovative mechatronics solutions in its four divisions: Electrical Connectors, Fluid Connectors, Robotics, and Textile. At Stäubli Electrical Connectors, we develop advanced connection solutions based on the reliable MULTILAM contact technology.

Together for reliable and safe connections

We know that you entrust us with the functionality of your applications and we work hard to ensure this every single day. Thanks to our high level of expertise, our extensive experience and the multiple successful co-operation with our partners, numerous new developments have originated at Stäubli Electrical Connectors and subsequently have become worldwide standards. This includes our MC4 connector portfolio for which we are today the global market

We create connections for life – and our customers are at the center of these connections. We are convinced that solid and stable partnerships directly contribute to our mutual success.

We take on the needs of our partners and deal with the most extraordinary challenges. As a result, we always create, sell and

leader in photovoltaic. As the Stäubli original, the MC4 represents the result of our constant quest for innovation, quality and safety.

Further examples are the CombiTac modular connector system or the Quick Charging Connector (QCC) for automatic charging systems.

We ensure connections for life together with our long-standing customers in a wide range of industries from renewable energies, power transmission and distribution and E-mobility to industrial automation applica-

support reliable and long-lasting products for markets with the highest productivity and safety requirements in close cooperation with our customers.

tions, railway and welding automation, test and measurement and medical devices.

Thus, developing reliable, efficient and safe solutions based on our proven MULTILAM contact technology, which guarantees a high service lifetime in addition to highly efficient power transmission.

Applications and advantages



CombiTac modular connectors combine various connection types in a single frame or housing and can be configured according to your exact specifications.

Depending on your application needs, two types of CombiTac products are available, CombiTac uniq and CombiTac direqt.

CombiTac uniq is designed for more demanding applications that require versatile long-life modular connector solutions, and where combination of power, signal, data, fiber optic, fluid and pneumatic connections are needed.

CombiTac uniq is 100 % customizable to meet exact technical and dimensional specifications, and thanks to the tried and

tested MULTILAM Technology, its contacts can reach up to 100,000 mating cycles and current levels up to 300 A.

As a solutions provider, and depending on your business needs, we offer you extensive A-Z support in configuring your own 100 % customized CombiTac modular connector, including cable assembly if required.

CombiTac direqt is ideal for applications where fast tool-free assembly is required, and where it is necessary to combine electrical signal, power and pneumatic connections up to 10,000 mating cycles. Particularly in applications where a high quantity of modular connectors for low power and signals are needed, CombiTac direqt offers significant economic advantages.

This product catalog is dedicated to the CombiTac uniq product line. To find out more about CombiTac direqt, please refer to the CombiTac direqt catalog.

Further information concerning product portfolio, special features as well as exemplary videos can be found at www.combitac.com

Content

Page 6	The world of CombiTac <ul style="list-style-type: none"> • Plug into more possibilities • CombiTac Configurator 	Page 44	Coaxial unit 1.5 GHz
Page 8	CombiTac uniq	Page 46	100 Mbit, 10 Gbit Data transfer unit <ul style="list-style-type: none"> • CAT 5 Ethernet • 10Gbit module CAT6A Ethernet  • RJ45 CAT 5 Ethernet
Page 10	Ø 12 mm Power unit <ul style="list-style-type: none"> • Up to 300 A, 1000 V • For details on  see page 138 	Page 52	Optical fiber unit POF <ul style="list-style-type: none"> • (Plastic optical fiber)
Page 18	Ø 8 mm Power unit <ul style="list-style-type: none"> • Up to 150 A, 1000 V • For details on  see page 138 	Page 54	Optical fiber unit GOF <ul style="list-style-type: none"> • (Glass optical fiber)
Page 20	Ø 6 mm, Ø 8 mm Power unit <ul style="list-style-type: none"> • Up to 125 A, 150 A, 1000 V • For details on  see page 138 	Page 56	Thermocouple unit
Page 22	Ø 6 mm Power unit <ul style="list-style-type: none"> • Up to 120 A, 1000 V • For details on  see page 138 	Page 60	Pneumatic and fluid units <ul style="list-style-type: none"> • Compressed air – vacuum unit • Coolant unit
Page 24	Ø 3 mm Power unit <ul style="list-style-type: none"> • Up to 40 A, 1000 V • For details on  see page 138 	Page 74	Spacers
Page 28	Ø 3 mm High voltage unit <ul style="list-style-type: none"> • Up to 5 kV, 42 A • For details on  see page 138 	Page 76	End pieces
Page 30	Ø 1.5 mm High voltage unit <ul style="list-style-type: none"> • Up to 2.5 kV, 19 A • For details on  see page 138 	Page 78	Single parts for CombiTac frames
Page 32	Ø 1.5 mm Signal unit <ul style="list-style-type: none"> • Up to 19 A, 600 V • For details on  see page 138 	Page 79	Calculation of installation dimensions
Page 34	Ø 1 mm Signal unit <ul style="list-style-type: none"> • Up to 12 A, 300 V • For details on  see page 138 	Page 82	Panel mounted
Page 38	Ø 0.6 mm Signal unit <ul style="list-style-type: none"> • Up to 6 A, 150 V 	Page 84	Housings <ul style="list-style-type: none"> • Aluminum housing IP65 • Housings with space saving locking • Aluminum housing IP68/69K • Plastic housing IP65 • Protective grounding of conductive housings For details on  see page 138 • Light housing for testing applications
Page 40	Last Mate First Break module <ul style="list-style-type: none"> • For details on  see page 138 	Page 122	Crimping pliers
Page 42	Coaxial unit 6 GHz <ul style="list-style-type: none"> • For details on  see page 138 	Page 124	Assembly tools
		Page 127	Appendix <ul style="list-style-type: none"> • Derating diagrams • Technical information • Index

General information

Changes/provisos

All data, illustrations and drawings in the catalog have been carefully checked. They correspond to our previous experience, but no liability can be accepted for errors.

We also reserve the right to make changes for construction and safety reasons. It is therefore advisable not to rely solely on the information in the catalog when designing devices in which our components are installed, but to consult us to ensure that this information is up to date. We would be happy to advise you.

Copyright

The use of this catalog for any other purpose, in whatever form, without our prior written consent is not permitted.

Symbols



Accessories or special tools exist for this product



The assembly instructions MA000 are available for this product



Surface Ag



Surface Au

Abbreviations

CT	= CombiTac uniq
S	= Screw termination/ Socket
P	= Pin
PCB	= Flow soldered termination
C	= Crimp termination
L	= Soldering
AWG	= American Wire Gauge

Aluminum DIN housings IP65

S	= Side cable entry
G, T	= Top cable entry
CH, TG	= Coupler hood
CHG, KG	= Coupler housing
PW	= Protective wall
PC	= Protective cover/cap
SM, AG	= Surface mount
PM, SG	= Pedestal mount
PS	= Park station
SD-...L/FSCH	= Plastic protective cover with lanyard for metal housing IP65
SSL	= Space saving locking

Aluminum housings IP68/69K,

Plastic housings IP65

CH, TG	= Coupler hood
SM, AG	= Surface mount
PM, SG	= Pedestal mount
ZV	= Central locking
PC	= Protective cover/cap
PS	= Park station
S	= Side cable entry
G	= Top cable entry

RoHS Conformity

European Directive 2011/65/EU (RoHS 2)

Commission Delegated Directive (EU) 2015/863 (RoHS 3)

For further information please visit our website

www.staubli.com/global/en/electrical-connectors/downloads/certificates/rohs-conformity.html

THE WORLD OF COMBITAC

Plug into more possibilities

Experience combined with quality and modularity leads to cost-efficient, and durable connection solutions. The modular connector system CombiTac can be easily configured online and adapted to meet the most

demanding requirements. Reliability when you need it. Flexibility, if you want it: The world of CombiTac's modular connector system meets your needs.

CombiTac direct



Click & connect
Most assembly-effective
10,000 mating cycles

The latest generation of modular connectors for power, signal, and pneumatic connections up to 10,000 mating cycles. The new user-friendly, tool-free click-and-connect system allows you to assemble your modular connector system in the most time-saving way.

CombiTac uniq



100 % customizable
Highest performance
100,000 mating cycles

Modular connectors for power, signal, data, pneumatic and fluid connections up to 100,000 mating cycles. Offers the highest possible performance and can be customized to meet exact technical and dimensional specifications.

CombiTac Configurator

The CombiTac configurator is a web application that enables you to put together your personalized CombiTac configuration

step by step on various end devices. It also allows you to receive a quotation for your selected CombiTac modular connector.



CombiTac Configurator

<https://configurator.combitac.com>

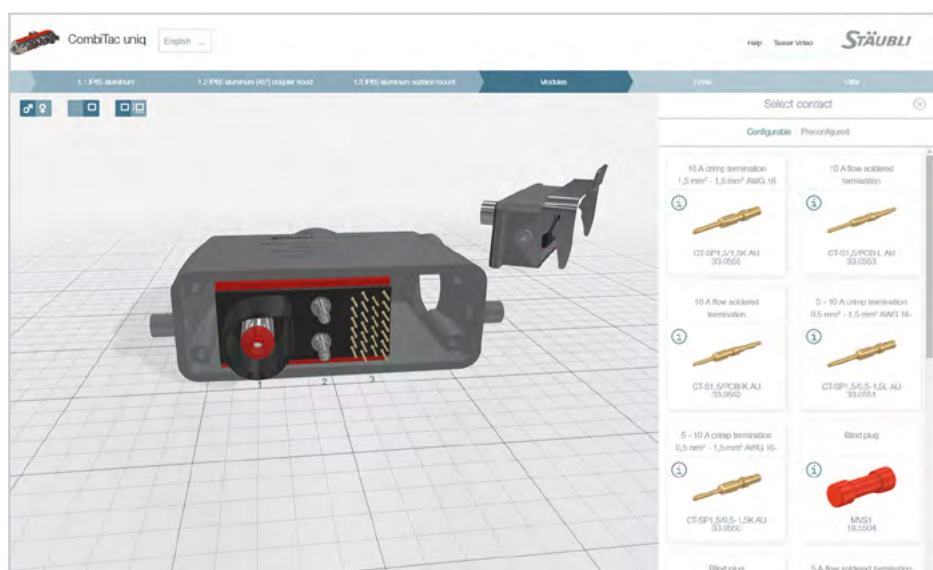

COMBITAC UNIQ

The modular connector system

DIN coupler hoods

6 different sizes

Rails

Included in delivery

May be ordered separately

End pieces in 2 versions

- Housing assembly
- Panel mounting

Included in delivery

May be ordered separately

Delivery status of the CombiTac

- Contact carriers mounted on rails
- Assembled with end pieces
- Contacts separately
- Gas and fluid couplings will be mounted in the carriers
- PCB contacts will be mounted on request

Possible connections

- Electric
- Thermocouple pressure contacts
- Coaxial
- Optical fiber
- Compressed air
- Liquid
- Electric + PE
- Data transfer

Fully assembled CombiTac connector with connecting lines

On request

DIN surface and pedestal mount housing

6 different sizes

Mating cycles

Panel mounted: up to 100,000

Housing assembly: up to 10,000

For the connector, the lowest mating cycle value of the individual components applies.





Ø 12 MM POWER UNIT UP TO 300 A

Contact carriers CT-E12-1/...

1-pole plastic contact carriers. Different designs for pins and sockets.

The contacts are locked by means of a retaining clip CT-RC12.

CT-E12-1/B

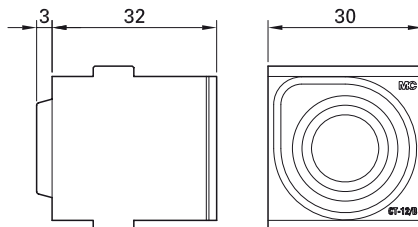

CT-E12-1/S

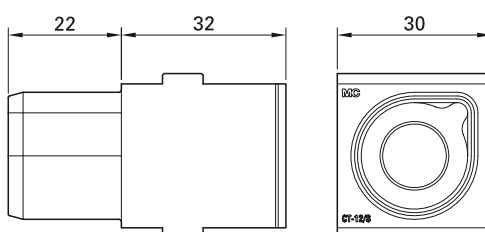

CT-RC12

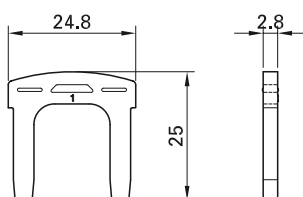

Assembly instructions MA213-01

www.staubli.com/electrical

Order No.	Type	Description
33.4082	CT-E12-1/B	Socket carrier (identification "B")
33.4081	CT-E12-1/S	Pin carrier (identification "S")
33.4083	CT-RC12	Retaining clip (not included with carriers)

Technical data		
Number of poles	1	
For contact diameter	12 mm	
Pollution degree/overvoltage category	2/CAT II	3/CAT III
Rated voltage, crimp termination screw termination	1000 V	800 V 400 V
Rated voltage UL	600 V	
Degree of protection (socket and plug front)	IP2X	
Clearances and creepage distance	IEC 60664-1:2020 and UL 1977	
Limiting temperature (IEC 61984:2008), upper lower	+90 °C -40 °C	
Contact carrier material	PA	

Ø 12 mm contacts with crimp termination

For contact carriers CT-E12-1/... Sockets fitted with MULTILAM.

Type of termination:
Crimp termination (C) for Cu conductors (class 5 and 6)

CT-BP12/...



CT-SP12/...

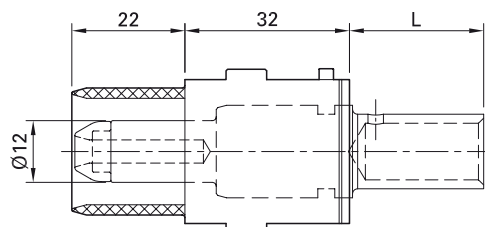

Order No.	Type	Socket	Pin	Surface	Conductor cross section		Rated current ¹⁾ A	Type of termination
					mm ²	AWG		
33.0127 33.0558	CT-BP12/50 AG CT-SP12/50 IP2X AG	×	×		50	1/0	200	C
33.0128 33.0559	CT-BP12/70 AG CT-SP12/70 IP2X AG	×	×		70	2/0	245	C
33.0138 33.0562	CT-BP12/95 AG CT-SP12/95 IP2X AG	×	×		95	4/0	300	C

Technical data

Nominal-Ø socket/pin	12 mm
Average sliding force	28 N
Connector resistance	< 25 µΩ
Mating cycles	100,000

¹⁾ IEC Rated values refer to copper wires in accordance with IEC 60364-5-52:2009.



Assembly instructions MA213-01

www.staubli.com/electrical

Ø 12 mm contacts with M10 inside thread

For contact carriers CT-E12-1/... Sockets fitted with MULTILAM

Type of termination:

Screw termination (S) using an M10 inside thread by means of a cable lug for Cu conductors (class 5 and 6)

Note:

Screw terminations can not be fitted in housings due to space limitations.

CT-B12/M10 AG



CT-S12/M10 IP2X AG

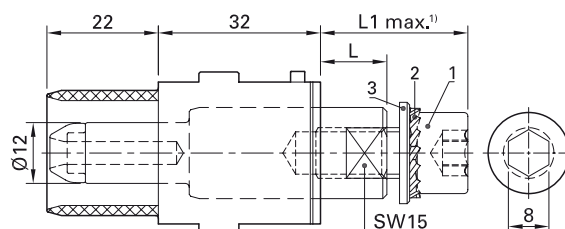

Order No.	Type	Socket	Pin	Surface	Conductor cross section		Rated current ²⁾	Type of termination
					mm ²	AWG		
33.0139	CT-B12/M10 AG	x			50	1/0	200	S
					70	2/0	245	
					95	4/0	300	
33.0564	CT-S12/M10 IP2X AG		x		50	1/0	200	S
					70	2/0	245	
					95	4/0	300	
33001501	K-SCH50-10 ³⁾	Cable lug			50	1/0		
33.4114	K-SCH70-10 ³⁾	Cable lug			70	2/0		
33.4115	K-SCH95-10 ³⁾	Cable lug			95	4/0		

Individual parts (supplied with 33.0139 and 33.0564)

Pos.	Order No.	Type	Remarks
1	11004669	ZYL-SHR-IN-6KT M10x20 ISO4762 BN610	Cheese head screw M10x20
2	08.0706	F/M10 DIN6798A BN781	Serrated lock washer F/M10
3	08.0306	U/M10 AG	Washer M10

Technical data	
Nominal-Ø socket/pin	12 mm
Average sliding force	25 N
Connector resistance	< 25 µΩ
Mating cycles	100,000

¹⁾ Depending on cable lug size.
²⁾ IEC Rated values refer to copper wires in accordance with IEC 60364-5-52:2009.
³⁾ Cable lugs Cu/Sn according to DIN 46234.

Selection of special DIN housings for CombiTac Ø 12 mm power unit

Step 1: Select the number of Ø 12 mm contacts of your CombiTac connector (e.g. 2 x Ø 12 mm contacts)

Step 2: Select the outer insulation diameter of your cable (e.g. 17 mm)

Step 3: Select the appropriate cable gland (e.g. order No. 33.4126 or 33.4122)

Step 4: Select a suitable DIN housing (e.g. size 3, order No. 33.2713)

1 Number of contacts	2 For Ø cable mm	3 Cable gland				4 Suitable housing			
		Size M	Order No.	Type	Wrench size max. mm	Size	Order No.	Type	Position of cable glands
2	9.5 – 12.5	25	33.4120	CT-K-VSH M25x9,5-12,5 MS	30	3	33.2713	CT-CH3-T/2xM25	
	10 – 17		33.4126	CT-K-VSH M25x10-17 MS	28				
	16 – 20.5		33.4122	CT-K-VSH M25x16-20,5 MS	30				
	17 – 21	32	33.4124	CT-K-VSH M32x17-21 MS	36	4	33.2814	CT-CH4-T/2xM32	
	21 – 25		33.4125	CT-K-VSH M32x21-25,5 MS	36				
3	10 – 17	25	33.4126	CT-K-VSH M25x10-17 MS	28	4	33.2744	CT-CH4-T/3xM25	
	9.5 – 12.5	25	33.4120	CT-K-VSH M25x9,5-12,5 MS	30	5 ¹⁾	33.3175	CT-CH5-T/4xM25	
	10 – 17		33.4126	CT-K-VSH M25x10-17 MS	28				
	16 – 20.5		33.4122	CT-K-VSH M25x16-20,5 MS	30				
	17 – 21	32	33.4124	CT-K-VSH M32x17-21 MS	36	6 ¹⁾	33.3196	CT-CH6-T/3xM32	
21 – 25	33.4125		CT-K-VSH M32x21-25,5 MS	36					
4	9.5 – 12.5	25	33.4120	CT-K-VSH M25x9,5-12,5 MS	30	5 ¹⁾	33.3175	CT-CH5-T/4xM25	
	10 – 17		33.4126	CT-K-VSH M25x10-17 MS	28				
	16 – 20.5		33.4122	CT-K-VSH M25x16-20,5 MS	30				
	17 – 21	32	33.4124	CT-K-VSH M32x17-21 MS	36	6+	33.1386	CT-TG6+ ³⁾	
	21 – 25		33.4125	CT-K-VSH M32x21-25,5 MS	36				
5	10 – 17	25	33.4126	CT-K-VSH M25x10-17 MS	28	6 ¹⁾	33.3186	CT-CH6-T/6xM25 ²⁾	
	17 – 21	32	33.4124	CT-K-VSH M32x17-21 MS	36	6+	33.1386	CT-TG6+ ³⁾	
	21 – 25		33.4125	CT-K-VSH M32x21-25,5 MS	36				
4	17 – 21 21 – 25	32	33.4125	CT-K-VSH M32x21-25,5 MS	36	6 ¹⁾	33.3206	CT-CH6-T/4xM32	

¹⁾ IP2X

²⁾ Close one gland opening with cap (not provided).

³⁾ Special housings available on request.

Contact carriers CT-E8/6-...

1-pole contact carrier made of resilient plastic. **Marked with a protective earth (PE) symbol.**

CT-E8/6-PE 

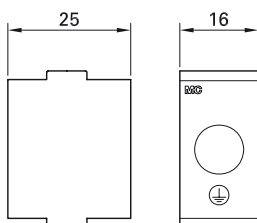

Order No.	Type	Description
33.4008	CT-E8/6-PE	Contact carrier with 

Technical data	
Number of poles	1
For contact diameter	8 mm/6 mm
Degree of protection (socket and plug front)	IP00
Limiting temperature (IEC 61984:2008), upper	+90 °C
lower	-40 °C
Contact carrier material	EPTR



E229145



Assembly instructions MA213-01

www.staubli.com/electrical

Ø 8 mm first mate contacts with crimp termination

For contact carrier CT-E8/6-PE. Sockets fitted with MULTILAM. For protective earth (PE) purposes only.

Type of termination:
Crimp termination (C) for Cu conductors (class 5 and 6)

CT-BP8/...PE-L AG



CT-SP8/...PE-L AG

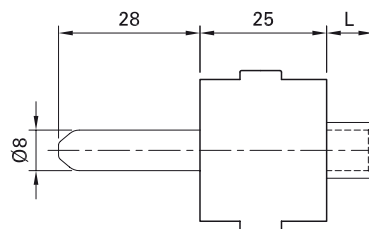

Order No.	Type	Socket	Pin	Surface	Conductor cross section		Short circuit current 3s kA	Type of termination
					mm ²	AWG		
33.0205	CT-BP8/25/PE-L AG	×			25	4	1.3	C
33.0705	CT-SP8/25/PE-L AG		×		25	4	1.3	C
33.0206	CT-BP8/35/PE-L AG	×			35	2	1.6	C
33.0706	CT-SP8/35/PE-L AG		×		35	2	1.6	C
33.0207	CT-BP8/50/PE-L AG	×			50	1/0	1.6	C
33.0707	CT-SP8/50/PE-L AG		×		50	1/0	1.6	C

Technical data

Nominal-Ø socket/pin	8 mm
Average sliding force	6.5 N
Mating cycles	100,000



Assembly instructions MA213-01

www.staubli.com/electrical

Ø 8 mm first mate contacts with M8 outside thread

For contact carrier CT-E8/6-PE, first mate. Sockets fitted with MULTILAM. For protective earth (PE) purposes only.

Type of termination:
Screw termination (S) with an M8 male thread by means of a cable lug for Cu conductors (class 5 and 6)

Note:
Screw terminations can not be fitted in housings due to space limitations.

CT-B8/M8A/PE-L AG



CT-S8/M8A/PE-L AG

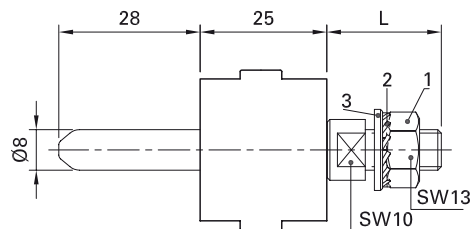

Order No.	Type	Socket	Pin	Surface	Conductor cross section		Short circuit current	Type of termination
					mm ²	AWG		
33.0208	CT-B8/M8A/PE-L AG	x			25	4	1.3	S
33.0708	CT-S8/M8A/PE-L AG		x		35	2	1.6	
					50	1/0	1.6	
33.4117	K-SCH25-8 ¹⁾	Cable lug			25	4	1.3	
33.4116	K-SCH35-8 ¹⁾	Cable lug			35	2	1.6	
31002862	K-SCH50-8 ¹⁾	Cable lug			50	1/0	1.6	
33.4085	CT-DIP4/2 ²⁾	Spacer						

Individual parts (supplied with 33.0208 and 33.0708)

Pos.	Order No.	Type	Remarks
1	08.0105	MU0,8D/M8 AG	6 kt. Hex. nut M8
2	08.0705	F/M8 DIN6798A BN781	Serrated lock washer F/M8
3	08.0305	U/M8 AG	Washer M8

Technical data	
Nominal-Ø socket/pin	8 mm
Average sliding force	5.5 N
Mating cycles	100,000

¹⁾ Cable lugs Cu/Sn according to DIN 46234 (class 5).
²⁾ Protective earth contacts with an M8 external thread must be separated from the Ø 12 mm contact by means of a CT-DIP4/2 spacer.



CombiTac: modular, compact, versatile

Ø 8 MM POWER UNIT UP TO 150 A

Contact carrier CT-E8-...

2-pole contact carriers made from resilient plastic.

To prevent flashover, there is a dividing wall between the two poles in the termination area.

CT-E8-2-IP2X

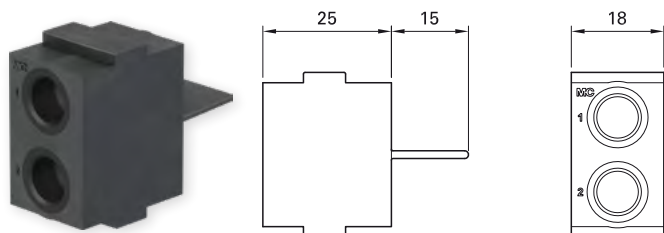

CT-E8-2

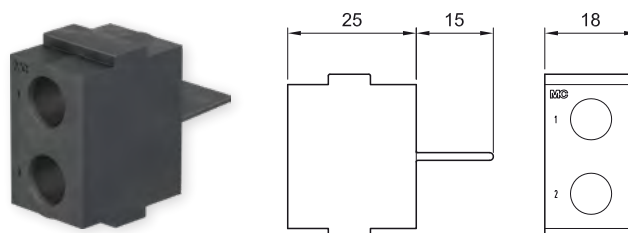

Order No.	Type	Description
33.4139	CT-E8-2-IP2X	Socket carrier (identification "B")
33.4000	CT-E8-2	Pin carrier

Technical data		
Number of poles	2	
For contact diameter	8 mm	
Pollution degree/overvoltage category	2/CAT II ²⁾	3/CAT III
Rated voltage, crimp termination	1000 V	300 V
screw termination	600 V	300 V
Rated voltage UL	600 V	
Degree of protection (socket front)	IP2X	
Clearances and creepage distance	IEC 60664-1:2020 and UL 1977	
Limiting temperature (IEC 61984:2008), upper	+90 °C	
lower	-40 °C	
Contact carrier material	EPTR	

Footnotes and technical data from pages 19:

Technical data	
Nominal-Ø socket/pin	8 mm
Average sliding force	5.5 N
Connector resistance	< 150 µΩ
Mating cycles	100,000
Vibrations	4.2 g/5 – 250 Hz (IEC 61373:2010) 10 g/10 – 500 Hz (IEC 60068-2-6)
Resistance to shocks	30 g/18 ms (IEC 61373:2010)



* Pin size same for all types of terminations.

¹⁾ IEC Rated current for fully occupied carriers. Derating diagrams for bundled cables see pages 127 – 131. For details on UL see page 138.

²⁾ If the rated voltage at CAT II PD2 is higher than 600 V, only 1 contact per contact carrier permitted.

³⁾ Cable lugs for smaller conductor cross sections (acc. to DIN 46234) are available commercially.

⁴⁾ Arrangement of blind plugs with one contact per carrier. For contacts with crimp termination only.



Assembly instructions MA213-01

www.staubli.com/electrical

Ø 8 mm contacts

For contact carrier CT-E8-2-IP2X and CT-E8-2. Sockets fitted with MULTILAM.

Type of termination:

- Crimp termination (C) for Cu conductors (class 5 and 6)
- Screw termination (S) for cable lugs and contacts with M6 inside or outside thread

Note:

Screw terminations can not be fitted in housings due to space limitations.

CT-BP8/...



CT-SP8/...



CT-E8-2-IP2X

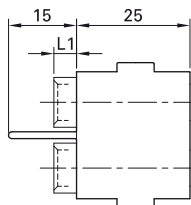

CT-E8-2

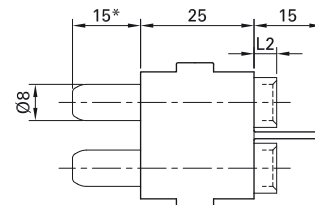

Order No.	Type	Socket	Pin	Surface	Conductor cross section		Rated current ¹⁾	Type of termination
					mm ²	AWG		
33.0100 33.0500	CT-BP8/10 AG CT-SP8/10 AG	x	x		10	8	55	C
33.0101 33.0501	CT-BP8/10 AU CT-SP8/10 AU	x	x					
33.0102 33.0502	CT-BP8/16 AG CT-SP8/16 AG	x	x		16	6	75	C
33.0103 33.0503	CT-BP8/16 AU CT-SP8/16 AU	x	x					
33.0104 33.0504	CT-BP8/25 AG CT-SP8/25 AG	x	x		25	4	100	C
33.0105 33.0505	CT-BP8/25 AU CT-SP8/25 AU	x	x					
33.0106 33.0506	CT-BP8/35 AG CT-SP8/35 AG	x	x		35 ²⁾	2	120 ^{1)/150}	C
33.0110 33.0510	CT-B8/M6 AG CT-S8/M6 AG	x	x		10	8	55	S
33.0111 33.0511	CT-B8/M6 AU CT-S8/M6 AU	x	x		16	6	75	
33.0120 33.0520	CT-B8/M6A AG CT-S8/M6A AG	x	x		25	4	100	
33.0121 33.0521	CT-B8/M6A AU CT-S8/M6A AU	x	x		35	2	120	S
33.4039	K-SCH35-6 ³⁾	Cable lug			35	2		
33.4050	CT-BS8	Blind plug ^{2), 4)}						

Ø 6 MM AND Ø 8 MM PROTECTIVE EARTH (PE) UNIT

Contact carriers CT-E8/6-...

1-pole contact carrier made of resilient plastic. **Marked with a protective earth (PE) symbol.**

CT-E8/6-PE 

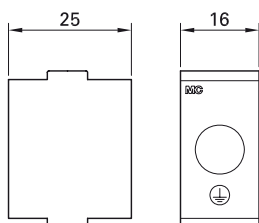

Order No.	Type	Description
33.4008	CT-E8/6-PE	Contact carrier with 

Technical data	
Number of poles	1
For contact diameter	8 mm/6 mm
Degree of protection (socket and plug front)	IP00
Limiting temperature (IEC 61984:2008), upper	+90 °C
lower	-40 °C
Contact carrier material	EPTR



E229145



Assembly instructions MA213-01

www.staubli.com/electrical

First mate contacts Ø 6 mm and Ø 8 mm

For contact carriers CT-E8/6-PE, first mate. Sockets fitted with MULTILAM. For protective earth (PE) purposes only.

Type of termination:

- Crimp termination (C) for Cu conductors (class 5 and 6)
- Screw termination (S) for cable lugs

Note:

Screw terminations can not be fitted in housings due to space limitations.

CT-B...PE AG



CT-S...PE AG

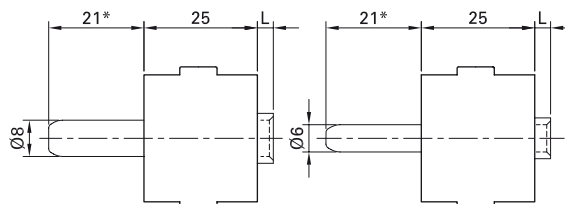

Order No.	Type	Socket	Pin	Surface	Conductor cross section		Short circuit current	Type of termination
					mm ²	AWG		
33.0113	CT-BP6/16/PE AG	x			16	6	860	C
33.0513	CT-SP6/16/PE AG		x		16	6	860	C
33.0123	CT-B6/M5A/PE AG	x			6	10	320	S
33.0523	CT-S6/M5A/PE AG		x		10	8	540	
					16	6	860	
					25	4	1600	
33.0114	CT-BP8/25/PE AG	x			25	4	1300	C
33.0514	CT-SP8/25/PE AG		x		25	4	1300	C
33.0119	CT-B8/M6A/PE AG	x			10	8	540	S
33.0519	CT-S8/M6A/PE AG		x		16	6	860	
					25	4	1300	
					35	2	1600	
33.4039	K-SCH35-6 ¹⁾	Cable lug			35	2	fits with CT...8...	

Technical data

Nominal-Ø socket/pin	6 mm/8 mm
Average sliding force	7.5 N/5.5 N
Connector resistance	< 250 µΩ/< 150 µΩ
Mating cycles	100,000
Vibrations	4.2 g/5 – 250 Hz (IEC 61373:2010) 10 g/10 – 500 Hz (IEC 60068-2-6)
Resistance to shocks	30 g/18 ms (IEC 61373:2010)

* Pin size same for all types of terminations.

¹⁾ Cable lugs for smaller conductor cross sections (according to DIN 46234) are available commercially.

Ø 6 MM POWER UNIT UP TO 120 A

Contact carrier CT-E6-2

2-pole contact carrier made of resilient plastic. To prevent flashover, there is a dividing wall between the two poles in the termination area.

CT-E6-2

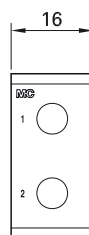
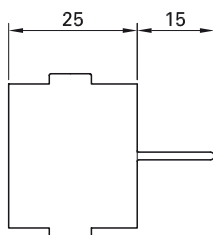
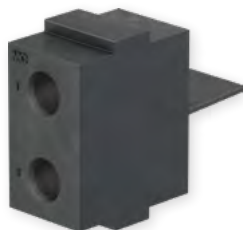

Order No.	Type
33.4006	CT-E6-2

Technical data		
Number of poles	2	
For contact diameter	6 mm	
Pollution degree/overvoltage category	2/CAT II	3/CAT III
Rated voltage, crimp termination	1000 V	500 V
Rated voltage, screw termination	600 V	300 V
Rated voltage UL	600 V	
Degree of protection (socket front)	IP2X	
Clearances and creepage distance	IEC 60664-1:2020	
Limiting temperature (IEC 61984:2008), upper	+90 °C	
Limiting temperature (IEC 61984:2008), lower	-40 °C	
Contact carrier material	EPTR	



E229145



Assembly instructions MA213-01

www.staubli.com/electrical

∅ 6 mm contacts

For contact carriers CT-E6-2. Sockets fitted with MULTILAM.

Type of termination:

- Crimp termination (C) for Cu conductors (class 5 and 6)
- Screw termination (S) for cable lugs and contacts with an M5 inside or outside thread

Note:

Screw terminations can not be fitted in housings due to space limitations.

CT-B6...



CT-S6...

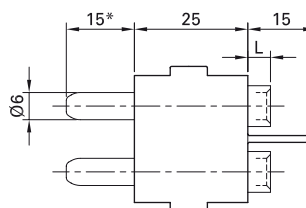

Order No.	Type	Socket	Pin	Surface	Conductor cross section		Rated current ¹⁾	Type of termination
					mm ²	AWG		
33.0107 33.0507	CT-BP6/6 AG CT-SP6/6 AG	x	x		6	10	40	C
33.0108 33.0508	CT-BP6/10 AG CT-SP6/10 AG	x	x		10	8	55	C
33.0109 33.0509	CT-BP6/16 AG CT-SP6/16 AG	x	x		16	6	75	C
33.0112 33.0512	CT-B6/M5 AG CT-S6/M5 AG	x	x		6 10 16 25	10 8 6 4	40 55 75 100	S ²⁾
33.0122 33.0522	CT-B6/M5A AG CT-S6/M5A AG	x	x		6 10 16 25	10 8 6 4	40 55 75 100	S ²⁾
18.5502	MVS5	Blind plug						

Technical data

Nominal-∅ socket/pin	6 mm
Average sliding force	7.5 N
Connector resistance	< 250 µΩ
Mating cycles	100,000
Vibrations	4.2 g/5 – 250 Hz (IEC 61373:2010) 10 g/10 – 500 Hz (IEC 60068-2-6)
Resistance to shocks	30 g/18 ms (IEC 61373:2010)

* Pin size same for all types of terminations.

¹⁾ IEC Rated current for fully occupied carriers. Derating diagrams for bundled leads, see pages 127 – 131. For details on UL see page 138.

²⁾ Cable lugs according to DIN 46234 are available commercially.



Assembly instructions MA213-01

www.staubli.com/electrical

Ø 3 MM POWER UNIT UP TO 40 A

Contact carriers CT-E3-3, CT-E3-3/PCB

3-pole contact carriers made of resilient plastic. Different contact carriers for crimping (C) or flow-soldering (PCB) termination.

CT-E3-3/B

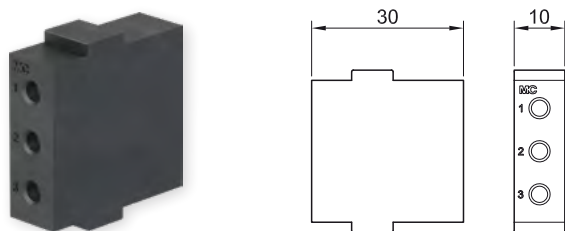

CT-E3-3

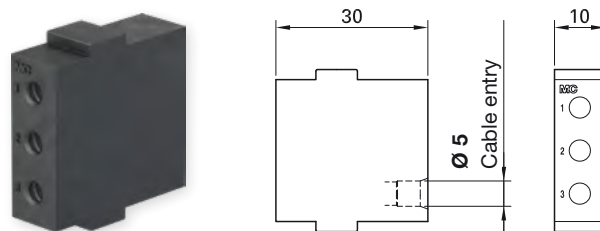

CT-E3-3/PCB/B

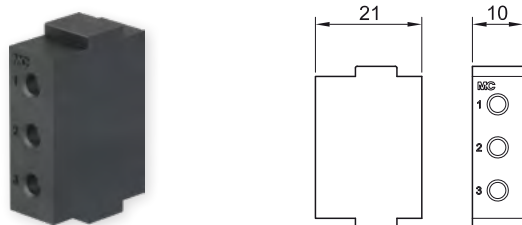

CT-E3-3/PCB

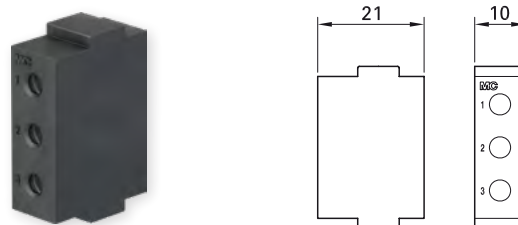

Order No.	Type	Description
33.4143	CT-E3-3/B	Socket carrier for crimping
33.4001	CT-E3-3	Pin carrier for crimping
33.4133	CT-E3-3/PCB/B	Socket carrier for flow-soldering
33.4004	CT-E3-3/PCB	Pin carrier for flow-soldering

Technical data		
Number of poles	3	
For contact diameter	3 mm	
Pollution degree/overvoltage category	2/CAT II	3/CAT III
Rated voltage	600 V ^{1), 2)}	300 V ²⁾ (CT-E3-3), 250 V (CT-E3-3/PCB)
Rated voltage UL	600 V	
Max. flow-soldering temperature/time	260 °C/3 s	
Degree of protection (socket front)	IP2X	
Clearances and creepage distance	IEC 60664-1:2020	
Limiting temperature (IEC 61984:2008), upper	+90 °C	
lower	-40 °C	
Contact carrier material	EPTR	

¹⁾ 600 V line to neutral, 690 V three phase according IEC 60664:2007.

²⁾ Rated voltage levels for pollution degree 2/overvoltage category CAT II above 600 V and up to 1000 V, along with rated voltage levels for pollution degree 3/overvoltage category CAT III above 300 V and up to 400 V, are possible with CT-E3-3 carriers depending on configuration type. This does not apply to CT-E3-3/PCB carriers. Please refer to assembly instructions MA213 for further details.



Assembly instructions MA213-01

www.staubli.com/electrical



∅ 3 mm contacts

For contact carriers CT-E3-3... Sockets fitted with MULTILAM.

Type of termination:

- Crimp termination (C) for Cu conductors (class 5 and 6)
- Flow-soldering (PCB)

CT-BP3...



CT-SP3...

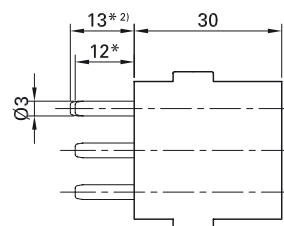

Order No.	Type	Socket	Pin	Surface	Conductor cross section		Rated current ¹⁾	Type of termination
					mm ²	AWG		
33.0131	CT-BP3/2,5-4 AU	x			2.5 4	14 12	22 35	C
33.0533 33.0531	CT-SP3/2,5-4L AU ²⁾ CT-SP3/2,5-4K AU		x x		2.5 – 4	14/12	22 – 35	
33.0137	CT-B3/PCB-K AU	x					35	PCB ³⁾
33.0537 33.0535	CT-S3/PCB-L AU ²⁾ CT-S3/PCB-K AU		x x				35 35	
18.5501	MVS3	Blind plug						

Technical data	
Nominal-∅ socket/pin	3 mm
Average sliding force	8 N
Connector resistance	< 1.1 mΩ
Mating cycles	100,000
Vibrations	4.2 g/5 – 250 Hz (IEC 61373:2010) 10 g/10 – 500 Hz (IEC 60068-2-6)
Resistance to shocks	30 g/18 ms (IEC 61373:2010)

* Pin sizes same for all type of terminations.

¹⁾ IEC Rated current for fully occupied carriers. Derating diagrams for bundled leads, see pages 127 – 131. For details on UL see page 138.

²⁾ Longer type of pin mates first.

³⁾ For drilling plans, see assembly instructions MA213-01.



Assembly instructions MA213-01

www.staubli.com/electrical

Contact carrier CT-E3-2+PE

3-pole contact carrier made of resilient plastic.

One pole functions as a protective earth (PE) contact and is **marked with a protective earth (PE) symbol**.

CT-E3-2+PE/B 

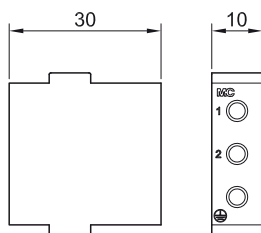

CT-E3-2+PE/S 

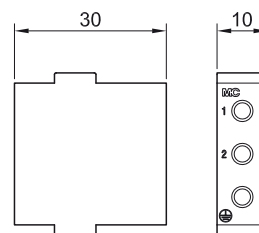

Order No.	Type	Description
33.4149	CT-E3-2+PE/B	Socket contact carrier for crimping
33.4132	CT-E3-2+PE/S	Pin contact carrier for crimping

Technical data		
Number of poles	2 + 1 PE	
For contact diameter	3 mm	
Pollution degree/overvoltage category	2/CAT II	3/CAT III
Rated voltage	600 V ^{1), 2)}	300 V ²⁾
Rated voltage UL	600 V	
Degree of protection (socket front)	IP2X ³⁾	
Clearances and creepage distance	IEC 60664-1:2020	
Limiting temperature (IEC 61984:2008), upper	+90 °C	
lower	-40 °C	
Contact carrier material	EPTR	



Assembly instructions MA213-01

www.staubli.com/electrical

¹⁾ 600 V line to neutral, 690 V three phase according IEC 60664:2007.

²⁾ Rated voltage levels for pollution degree 2/overvoltage category CAT II above 600 V and up to 1000 V, along with rated voltage levels for pollution degree 3/overvoltage category CAT III above 300 V and up to 400 V, are possible with CT-E3-2+PE carriers depending on configuration type. Please refer to assembly instructions MA213 for further details.

³⁾ Except for PE contact.

Ø 3 mm contacts

For contact carriers CT-E3-2+PE. Sockets fitted with MULTILAM. Protective earth (PE) contacts and standard contacts. PE contacts for protective earth (PE) purposes only.¹⁾

Type of termination:





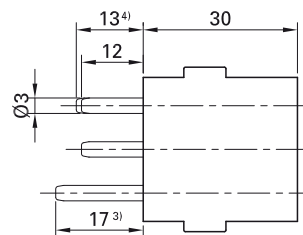

- Crimp termination (C) for Cu conductors (class 5 and 6)

CT-BP3/2,5-4/PE AU 

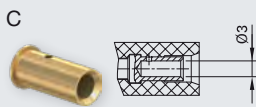

CT-SP3/2,5-4/PE AU 



Order No.	Type	Socket	Pin	Surface	Conductor cross section		Rated current ²⁾	Type of termination	
					mm ²	AWG			
33.0129	CT-BP3/2,5-4/PE AU ³⁾	x			2.5 4	14 12	- ¹⁾ - ¹⁾		
33.0529	CT-SP3/2,5-4/PE AU ³⁾		x		2.5 4	14 12	- ¹⁾ - ¹⁾		
33.0131	CT-BP3/2,5-4 AU	x			2.5 4	14 12	22 35		
33.0533	CT-SP3/2,5-4L AU ⁴⁾		x		2.5	14	22		
33.0531	CT-SP3/2,5-4K AU		x		4	12	35		
18.5501	MVS3	Blind plug							

Technical data	
Nominal-Ø socket/pin	3 mm
Average sliding force	8 N
Connector resistance	< 1.1 mΩ
Mating cycles	100,000
Vibrations	4.2 g/5 – 250 Hz (IEC 61373:2010) 10 g/10 – 500 Hz (IEC 60068-2-6)
Resistance to shocks	30 g/18 ms (IEC 61373:2010)

¹⁾ Short circuit current 3s
2.5 mm²: 135 A
4 mm²: 216 A

²⁾ IEC Rated current for fully occupied carriers. Derating diagrams for bundled leads, see pages 127 – 131. For details on UL see page 138.

³⁾ Protective earth (PE) contact.

⁴⁾ Longer type of pin mates first.



Assembly instructions MA213-01

www.staubli.com/electrical

Ø 3 MM HIGH VOLTAGE UNIT UP TO 5 KV

Contact carriers CT-E3-.../HV...

1- and 2-pole contact carriers made of resilient plastic. With PTFE insert.

Note:
The maximum outside diameter of the conductor insulation is 6.6 mm.

CT-E3-1/HV-B



CT-E3-2/HV-B

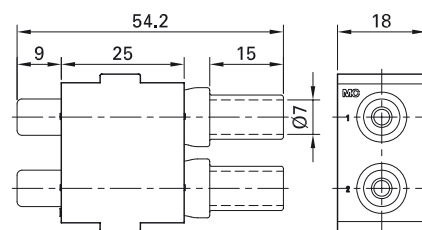

CT-E3-1/HV-S



CT-E3-2/HV-S

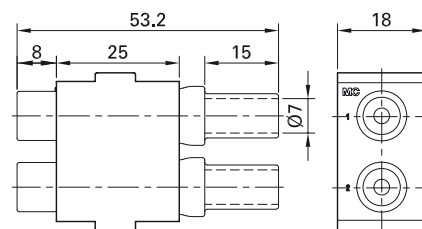
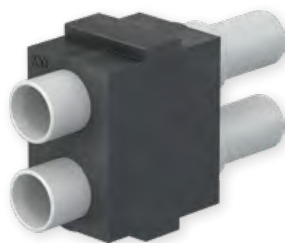

Order No.	Type	Description
33.4136	CT-E3-2/HV-B	2-pole socket carrier
33.4137	CT-E3-1/HV-B	1-pole socket carrier
33.4536	CT-E3-2/HV-S	2-pole pin carrier
33.4537	CT-E3-1/HV-S	1-pole pin carrier

Technical data	
Number of poles	1 or 2
For contact diameter	3 mm
Pollution degree	2
Rated voltage phase-to-earth	2.9 kV
Rated voltage phase-to-phase	5 kV
Rated voltage UL	600 V
Test Voltage 1 min., 50/60 Hz; phase-to-earth	6.6 kV
Test Voltage 1 min., 50/60 Hz; phase-to-phase	13.7 kV
Degree of protection (in mated condition)	IP2X
Limiting temperature (IEC 61984:2008), upper	+90 °C
lower	-40 °C
Contact carrier material	EPTR
Insulation material	PTFE



Assembly instructions MA213-05

www.staubli.com/electrical



Ø 3 mm/HV

For contact carrier CT-E.../HV-... Sockets fitted with MULTILAM.

Type of termination:

Crimp termination (C) for Cu high voltage conductors 2.5 mm², followed by insulation with shrink tubing CT-HV-SRTU

Note:

- All data regarding ratings apply to the mated condition
- Connector without breaking capacity (COC)
- The connector must not be connected or disconnected when live or under load

CT-BP3/2,5-HV AU



CT-SP3/2,5-HV AU

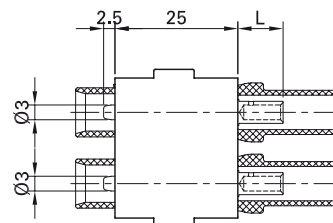

Order No.	Type	Socket	Pin	Surface	Conductor cross section		Rated current ¹⁾		Type of termination
					mm ²	AWG	2 poles	1 pole	
33.0163	CT-BP3/2,5-HV AU	×			2.5	14	25 A	32 A	
33.0563	CT-SP3/2,5-HV AU		×		4	12	32 A	42 A	

Accessories

33.5666	CT-HV-SRTU	Shrink tube 45mm (length) is included in the scope of delivery of the contact carrier. When ordering contacts as a spare part, the shrink tubing must be ordered separately in the appropriate quantity.	
---------	------------	--	--

Recommended cable

Order No.	Type	Conductor cross section		Rated current ¹⁾		Colors
		mm ²	AWG	2 poles	1 pole	
61.7634-*	SILI-HV 2,5	2.5	14	20 A	32 A	21 22

Technical data

Nominal-Ø socket/pin	3 mm
Average sliding force	8 N
Connector resistance	< 1.1 mΩ
Mating cycles	100,000
Vibrations	4.2 g/5 – 250 Hz (IEC 61373:2010) 10 g/10 – 500 Hz (IEC 60068-2-6)
Resistance to shocks	30 g/18 ms (IEC 61373:2010)



Assembly instructions MA213-05

www.staubli.com/electrical

* Add the desired color code.

¹⁾ IEC Rated current for fully occupied carriers. Derating diagrams for bundled leads, see pages 127 – 131. For details on UL see page 138.

Ø 1.5 MM HIGH VOLTAGE UNIT UP TO 2.5 KV

Contact carrier CT-E1,5-4/HV...

4-pole high voltage module up to 2.5 kV for general industry, railway, and testing applications.

Features:

- Space saving 4-pole solution
- Railway compliant material
- Resistance to shock and vibrations
- Tool-free insertion of contacts in carrier

CT-E1,5-4/HV-B

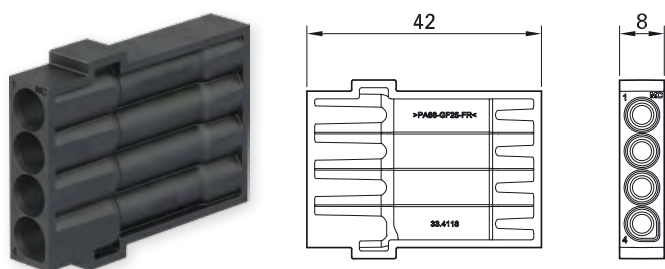

CT-E1,5-4/HV-S

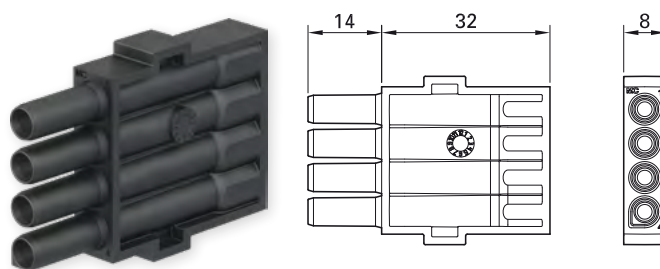

Order No.	Type	Designation
33.4118	CT-E1,5-4/HV-B	4-pole socket carrier
33.4518	CT-E1,5-4/HV-S	4-pole pin carrier

Technical data		
Number of poles	4	
For contact diameter	1.5 mm	
Pollution degree/overvoltage category	2/CAT II	3/CAT III
Rated voltage	U _{AC} 2000 V U _{DC} 2500 V	1000 V
Rated voltage UL	600 V	
Test voltage r.m.s. 1 min., 50/60 Hz	6.6 kV	
Degree of protection (socket front)	IP2X	
Limiting temperature (IEC 61984:2008), upper lower	+90 °C -40 °C	
Contact carrier material	PA	
Fire and smoke compliance	EN 45545-2 (HL2 R22)	



Assembly instructions MA213-05

www.staubli.com/electrical

Ø 1.5 mm/HV

For contact carrier CT-E1,5-4/HV-... Sockets fitted with MULTILAM.

Type of termination:

Crimp termination (C) for Cu high voltage conductors 0.5 mm² – 1.5 mm²

Note:

- For rated voltage above AC 1000 V, DC 1500 V the connector must not be connected or disconnected when live or under load. Apply voltage only in mated condition.

- High voltage module 2.5 kV used up to max. 30 kHz. Only to be used with plastic rails (CT-BS Order No.: 33.5606-...).

CT-BP1,5/0,5-1,5-HV

CT-SP1,5/0,5-1,5-HV

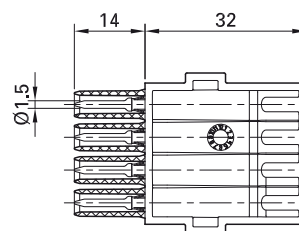
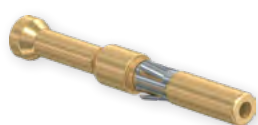

Order No.	Type	Socket	Pin	Surface	Conductor cross section		Rated current ¹⁾ A	Type of termination
					mm ²	AWG		
33.0169	CT-BP1,5/0,5-1,5-HV	x	x		0.5	20	6	
33.0569	CT-SP1,5/0,5-1,5-HV				0.75	18	9	
					1	-	11	
					1.5	16	14	

Technical data	
Nominal-Ø socket/pin	1.5 mm
Average sliding force	2 N
Connector resistance	< 1.3 mΩ
Mating cycles	100,000
Vibrations and shock	IEC 61373:2010 category 1B



Assembly instructions MA213-05

www.staubli.com/electrical

¹⁾ IEC Rated current for fully occupied carriers. Derating diagrams for bundled leads, see pages 127 – 131. For details on UL see page 138.

Required tools

For extraction tool CT-AWZ-2,5HV, Order No. 33.3006 please refer to MA213-05.

Ø 1.5 MM SIGNAL UNIT UP TO 19 A

Contact carrier CT-E1,5-5

5-pole contact carrier made of resilient plastic.

CT-E1,5-5

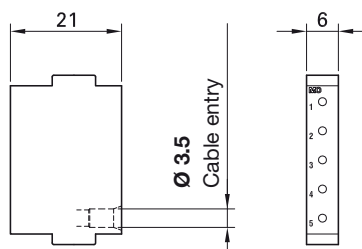

Order No.	Type
33.4005	CT-E1,5-5

Technical data	
Number of poles	5
For contact diameter	1.5 mm
Pollution degree/overvoltage category	2/CAT II 3/CAT III
Rated voltage	600 V 250 V
Rated voltage UL	600 V
Max. flow-soldering temperature/time	260 °C/3 s
Degree of protection (socket front)	IP2X
Clearances and creepage distance	IEC 60664-1:2020
Limiting temperature (IEC 61984:2008), upper	+90 °C
lower	-40 °C
Contact carrier material	EPTR



E229145



Assembly instructions MA213-01

www.staubli.com/electrical

Ø 1.5 mm contacts

For contact carriers CT-E1,5-5. Sockets fitted with MULTILAM.

Type of termination:

- Crimp termination (C) for Cu conductors (class 5) (CT-...P1,5/1,5... also for class 6)
- Flow-soldering (PCB)

CT-BP1,5...



CT-SP1,5...

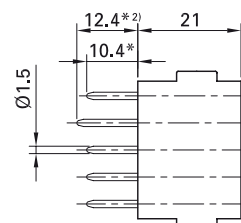

Order No.	Type	Socket	Pin	Surface	Conductor cross section		Rated current ¹⁾	Type of termination	
					mm ²	AWG			
33.0153	CT-BP1,5LAV/0,5-1,5 AU	x			0.5	20	5	C	
					0.75	18	8		
					1.0	18	10		
					1.5	16	10		
33.0551	CT-SP1,5/0,5-1,5L AU ²⁾		x		0.5	20	5	C	
33.0550	CT-SP1,5/0,5-1,5K AU		x		0.75	18	8		
					1.0	18	10		
					1.5	16	10		
33.0156	CT-BP1,5LAV/1,5 AU ³⁾	x			1.5	16	10	C	
33.0555	CT-SP1,5/1,5K AU ³⁾		x		1.5	16	10	C	
33.0157	CT-B1,5LAV/PCB AU	x			1.5	16	10	PCB ⁴⁾	
33.0553	CT-S1,5/PCB-L AU ²⁾		x				10	PCB ⁴⁾	
33.0552	CT-S1,5/PCB-K AU		x				10		
18.5504	MVS1	Blind plug							

Technical data	
Nominal-Ø socket/pin	1.5 mm
Average sliding force	2 N
Connector resistance	< 1.1 mΩ
Mating cycles	100,000
Vibrations	4.2 g/5 – 250 Hz (IEC 61373:2010) 10 g/10 – 500 Hz (IEC 60068-2-6)
Resistance to shocks	30 g/18 ms (IEC 61373:2010)



Assembly instructions MA213-01

www.staubli.com/electrical

* Pin size same for all types of terminations.

¹⁾ IEC Rated current for fully occupied carriers. Derating diagrams for bundled leads, see pages 127 – 131. For details on UL see page 138.

²⁾ Longer type of pin mates first.

³⁾ For Cu conductors (class 6).

⁴⁾ For drilling plans, see assembly instructions MA213-01.

Ø 1 MM SIGNAL UNIT UP TO 12 A

Contact carriers CT-E1-26/...

26-pole contact carrier made of resilient plastic. Different designs for pins and sockets.

For suitable contacts, see page 37.

CT-E1-26/B

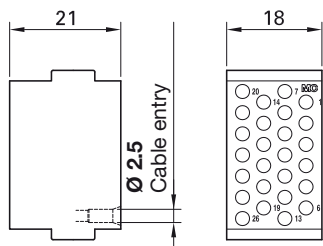

CT-E1-26/S

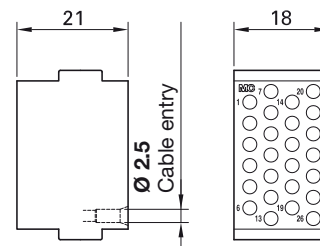

Order No.	Type	Description
33.4002	CT-E1-26/B	Socket carrier (identification "B")
33.4003	CT-E1-26/S	Pin carrier (identification "S")

Technical data		
Number of poles	26	
For contact diameter	1 mm	
Pollution degree/overvoltage category	2/CAT II	3/CAT III
Rated voltage	300 V	150 V
Rated voltage UL	250 V	
Max. flow-soldering temperature/time	260 °C/3 s	
Degree of protection (socket front)	IP2X	
Clearances and creepage distance	IEC 60664-1:2020	
Limiting temperature (IEC 61984:2008), upper	+90 °C	
lower	-40 °C	
Contact carrier material	EPTR	



E229145



Assembly instructions MA213-01

www.staubli.com/electrical

Contact carriers CT-E1-15/...

15-pole contact carrier made of resilient plastic. Different designs for pins and sockets.

For suitable contacts, see page 37.

CT-E1-15/B

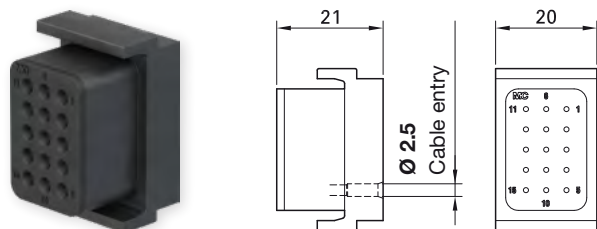

CT-E1-15/S

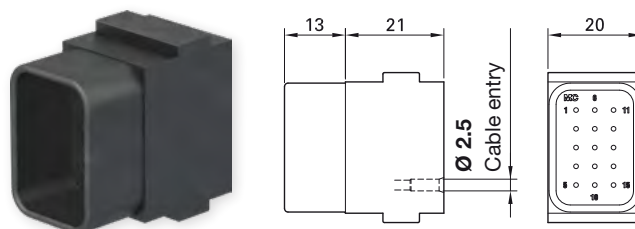

Order No.	Type	Description
33.4022	CT-E1-15/B	Socket carrier (identification "B")
33.4023	CT-E1-15/S	Pin carrier (identification "S")

Technical data		
Number of poles	15	
For contact diameter	1 mm	
Pollution degree/overvoltage category	2/CAT II	3/CAT III
Rated voltage	300 V	150 V
Rated voltage UL	250 V	
Max. flow-soldering temperature/time	260 °C/3 s	
Degree of protection (socket front)	IP2X	
Clearances and creepage distance	IEC 60664-1:2020	
Limiting temperature (IEC 61984:2008), upper	+90 °C	
lower	-40 °C	
Contact carrier material	PA & EPTR	



E229145



Assembly instructions MA213-01

www.staubli.com/electrical

Contact carrier CT-E1-6

6-pole contact carrier made of resilient plastic. For suitable contacts, see page 37.

CT-E1-6

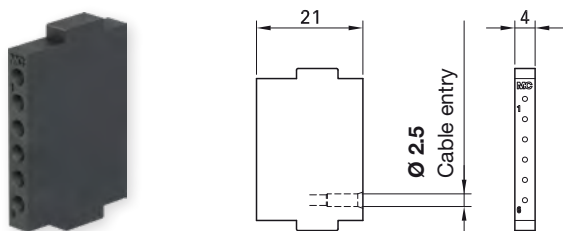

Order No.	Type
33.4014	CT-E1-6

Technical data		
Number of poles	6	
For contact diameter	1 mm	
Pollution degree/overvoltage category	2/CAT II	3/CAT III
Rated voltage	300 V	150 V
Rated voltage UL	250 V	
Max. flow-soldering temperature/time	260 °C/3 s	
Degree of protection (socket front)	IP2X	
Clearances and creepage distance	IEC 60664-1:2020	
Limiting temperature (IEC 61984:2008), upper	+90 °C	
lower	-40 °C	
Contact carrier material	EPTR	



E229145



Assembly instructions MA213-01

www.staubli.com/electrical

Ø 1 mm contacts

For contact carriers CT-E1-26/..., CT-E1-15/..., and CT-E1-6. Sockets fitted with MULTILAM.

Type of termination:

- Crimp termination (C) for Cu conductors (class 5 and 6)
- Flow-soldering (PCB)

CT-BP1...



CT-SP1...



CT-E1-26/...

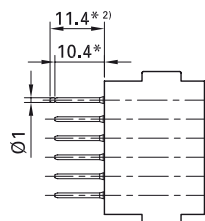

CT-E1-15/...

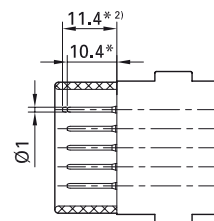

CT-E1-6

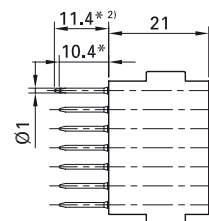

Order No.	Type	Socket	Pin	Surface	Conductor cross section		Rated current ¹⁾	Type of termination
					mm ²	AWG		
33.0141	CT-BP1/0,25-0,75 AU	x			0.25	24	2	C
33.0143	CT-BP1ET/0,25-0,75 AU	x			0.5	20	3	
					0.75	18	5	
33.0543	CT-SP1/0,25-0,75L AU ²⁾		x		0.25	24	2	
33.0541	CT-SP1/0,25-0,75K AU		x		0.5	20	3	
					0.75	18	5	
33.0145	CT-B1/PCB AU	x					5	PCB ³⁾
33.0146	CT-B1ET/PCB AU	x					5	
33.0547	CT-S1/PCB-L AU ²⁾		x				5	
33.0545	CT-S1/PCB-K AU		x				5	
33.4051	CT-BS1	Blind plug						

Technical data		
	CT-BP... & CT-B...	CT-BP1ET... & CT-B1ET...
Nominal-Ø socket/pin	1 mm	1 mm
Average sliding force	2 N	0.6 N
Connector resistance	< 1.6 mΩ	< 3 mΩ
Mating cycles	5000	100,000
Vibrations	4.2 g/5 – 250 Hz (IEC 61373:2010) 10 g/10 – 500 Hz (IEC 60068-2-6)	
Resistance to shocks	30 g/18 ms (IEC 61373:2010)	



Assembly instructions MA213-01

www.staubli.com/electrical

* Pin size same for all types of terminations.

¹⁾ IEC Rated current for fully occupied carriers. Derating diagrams for bundled leads, see pages 127 – 131. For details on UL see page 138.

²⁾ Longer type of pin mates first.

³⁾ For drilling plans, see assembly instructions MA213-01.

Ø 0.6 MM SIGNAL UNIT UP TO 6 A

Contact carriers CT-E0,6-20/...

20-pole contact carrier made of plastic. Different designs for pins and sockets. The inner wall of the pin carrier protects the contacts from mechanical damage. The contact

carrier is mechanically coded to prevent incorrect mating.

Note:

In combination with the contact carrier CT-E0,6-20/..., compensator CT-DIP1,3-3,4 might be needed to fill gaps in the CombiTac.

CT-E0,6-20/B

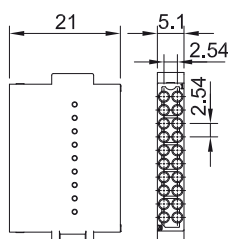

CT-E0,6-20/S

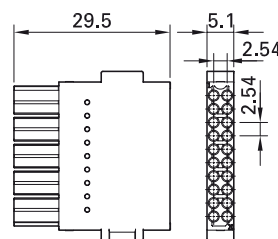

Order No.	Type	Description
33.4073	CT-E0,6-20/B	Socket carrier (identification "B")
33.4072	CT-E0,6-20/S	Pin carrier (identification "S")

Technical data		
Number of poles	20	
For contact diameter	0.6 mm	
Pollution degree/overvoltage category	2/CAT II	3/CAT III
Rated voltage	150 V	50 V
Max. flow-soldering temperature/time	260 °C/3 s	
Degree of protection (socket front)	IP2X	
Limiting temperature (IEC 61984:2008), upper	+90 °C	
lower	-40 °C	
Contact carrier material	LCP	



Assembly instructions MA213-01

www.staubli.com/electrical

Ø 0.6 mm contacts

For contact carriers CT-E0,6-20/...

Type of termination:

- Crimp termination (C) for Cu conductors
- Soldering (L) for Cu conductors
- Flow-soldering (PCB) for printed circuit boards

CT-B...



CT-S...

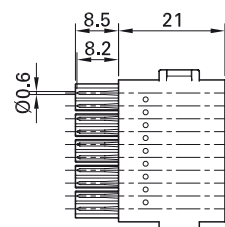

Order No.	Type	Socket	Pin	Surface	Conductor cross section		Rated current ¹⁾	Type of termination
					mm ²	AWG		
33.0126 33.0526	CT-BP0,6ET/0,14-0,25 AU CT-SP0,6/0,14-0,25 AU	x	x		0.14 0.25	26 24	1.4 2	C
33.0125 33.0525	CT-B0,6ET/LO AU CT-S0,6/LO AU	x	x		0.14 0.25	26 24	1.4 2	L
33.0124 33.0524	CT-B0,6ET/PCB AU CT-S0,6/PCB AU	x	x		0.14 0.25	26 24	1.4 2	PCB

Technical data

Nominal-Ø pin/socket	0.6 mm
Average sliding force	0.25 N
Connector resistance	< 6 mΩ
Mating cycles	100,000

Accessories

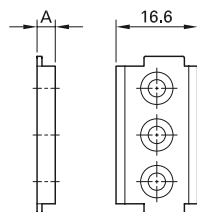

Order No.	Type	Designation	Size A
33.4096	CT-DIP1,3-3,4	Compensator	1.3 mm – 3.4 mm



Assembly instructions MA213-01

www.staubli.com/electrical

¹⁾ IEC Rated current for fully occupied carriers. Derating diagrams for bundled leads, see pages 127 – 131. For details on UL see page 138.

LAST MATE FIRST BREAK MODULE

Module CT-LMFB/...

Last Mate First Break (LMFB) contacts are intended for monitoring purposes, and show whether a CombiTac is fully connected or not. Each CombiTac LMFB module consists

of two LMFB contacts placed at the edge positions of a carrier. Suitable for panel mount and housing applications.

CT-LMFB/B

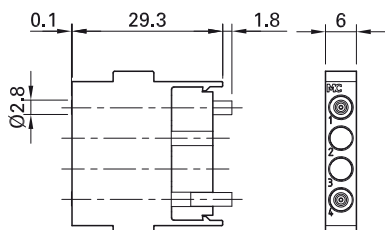

CT-LMFB/S

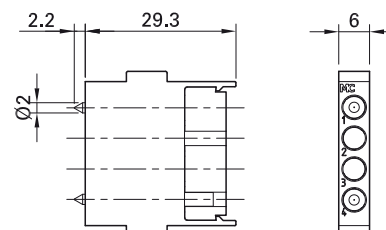

Order No.	Type	Description
33.2257	CT-LMFB/B	Socket module
33.2657	CT-LMFB/S	Pin module

Technical data

Contact carrier material	PA
Limiting temperature (IEC 61984:2008), upper	+90 °C
lower	-40 °C

Rails ≤ 90 mm¹⁾



E229145



Assembly instructions MA213-07

www.staubli.com/electrical

Last Mate First Break contacts CT-LMFB-...

To be used with contact carrier CT-E-4GOF for monitoring the connection status of electrical contacts Ø 1.5 mm – Ø 12 mm.

Type of termination:

- Crimp termination (C) for Cu conductors (class 5)
- Pressure contacts fitted with MULTILAM

CT-LMFB-B2/0,5-1,5 AU

CT-LMFB-S2/0,5-1,5 AU

Socket side

Pin side

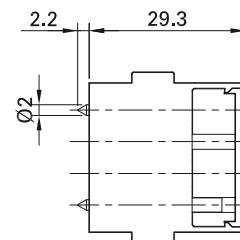
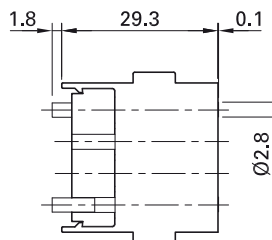

Order No.	Type	Socket	Pin	Surface	Conductor cross section		Type of termination
					mm ²	AWG	
33.0134	CT-LMFB-B2/0,5-1,5 AU	x	x		0.5	20	
33.0534	CT-LMFB-S2/0,5-1,5 AU				0.75	18	
					1.0	18	
					1.5	16	
33.4080	CT-BSGOF ²⁾	Blind plug					

Accessories

33.4157	CT-SC0,8	Spacer clamp	For housing size 1, 6 and pedestal housing size 5 ³⁾				
---------	----------	--------------	---	--	--	--	--

Technical data

Rated voltage/system voltage	U _{DC} 29.5 V
Max. signal current	100 mA
Average springforce per carrier (two contacts)	14 N
Mating cycles	100,000 ⁴⁾
Vibrations	3.1 g/5 – 250 Hz (IEC 61373:2010)
Resistance to shocks	30 g/18 ms (IEC 61373:2010)

¹⁾ Please consult Stäubli sales team regarding LMFB modules for Rails > 90 mm

²⁾ We recommend filling the two empty slots of the contact carrier with blind plugs.

³⁾ For housing size 1, 6 and pedestal housing size 5, a spacer clamp is used if improvement of tolerance levels is required. The space clamp is not included in the delivery and can be ordered separately if needed. For more information please refer to MA213-07 page 8.

⁴⁾ LMFB contacts are not suitable for inductive (e.g. relays) or capacitive loads. In such cases, arcing at the LMFB contacts during connecting/disconnecting may reduce the expected mating cycles of LMFB contacts.



Assembly instructions MA213-07

www.staubli.com/electrical

COAXIAL UNIT 6 GHz

Contact carrier

The Coaxial unit 6 GHz is used for data as well as digital audio and video transmission. Two types of termination are possible, crimp and SMA.

There are two crimp versions available, one for RG58 and one for RG316/U, RG174 and RG188 cables, and a SMA termination version for various cable types up to 6 GHz levels.

Features:

- Suitable for various 50 Ω RG cable types up to 6 GHz (depending on RG cable type)
- Crimp for RG58 cables up to 2.4 GHz
- Crimp for RG316/U, RG174, RG188 cables up to 2.4 GHz
- SMA for RG58, RG316/U, RG174, RG188 and other cables up to 6 GHz

- 100,000 mating cycles
- UL 1977 and Railway standard compliant
- Resistance to shock and vibrations
- Applications: data transmission, digital audio and video, HF measurement, radio communication.

CT-E-COAX-1

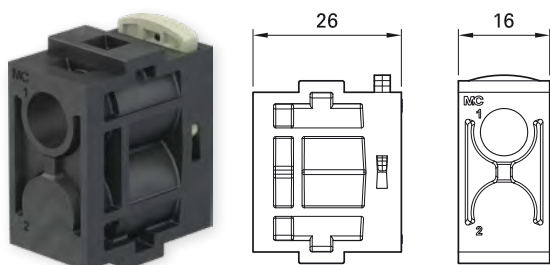

CT-E-COAX-2

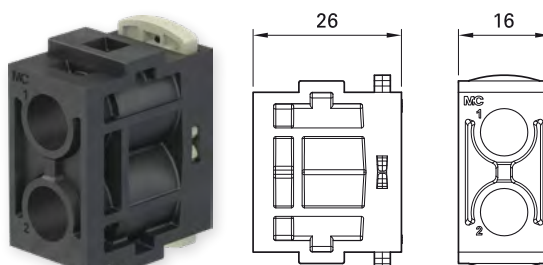

CT-RC-COAX



Order No.	Type	Designation
33.4180	CT-E-COAX-1	One pole coax carrier
33.4181	CT-E-COAX-2	Two pole coax carrier

Individual part (supplied with 33.4180 and 33.4181)

33.4182	CT-RC-COAX	Retaining clip (not included with carriers)
---------	------------	---

Technical data	
Number of poles CT-E-COAX-1	1
CT-E-COAX-2	2
For connectors	Coaxial crimp and SMA
Pollution degree	2
Limiting temperature (IEC 61984:2008)	-40 °C...+90 °C
Contact carrier material	PA
Fire and smoke compliance	EN 45545-2 (HL3 R22 – R23)



Assembly instructions MA213-11

www.staubli.com/electrical



Coaxial connectors

For contact carriers CT-E-COAX-1 and CT-E-COAX-2.

Type of termination:

- Crimp termination (C)
- SMA Termination (SMA)

CT-B-COAX-RG316/U



CT-S-COAX-RG316/U

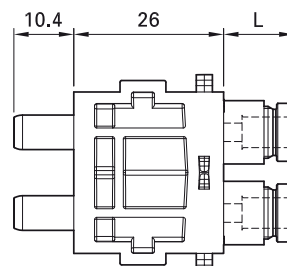

Order No.	Type	Socket	Pin	Suitable for cable types	Type of termination
33.0230 33.0630	CT-B-COAX-RG316/U CT-S-COAX-RG316/U	×	×	RG316/U, RG174, RG188	C
33.0231 33.0631	CT-B-COAX-RG58 CT-S-COAX-RG58	×	×	RG58	C
33.0250 33.0750	CT-B-COAX-SMA CT-S-COAX-SMA	×	×	RG58, RG316/U, RG174, RG188, other 50 Ω RG cable types up to 6 GHz	SMA

Technical data

Average sliding force per contact	Crimp: 5 N SMA: 12 N
Max. frequency	Crimp: 2.4 GHz SMA: 6 GHz
Voltage standing wave ratio (VSWR)	Crimp: 1.4 at 2.4 GHz SMA: 1.3 at 6 GHz
Rated voltage	UL 250 V, IEC 300 V
Rated current	250 mA
Impedance	50 Ω
Mating cycles	100,000
Vibrations and shock	IEC 61373:2010 category 1B
Degree of protection (socket front)	IP2X



Assembly instructions MA213-11

www.staubli.com/electrical

COAXIAL UNIT 1.5 GHZ

Contact carrier CT-E8-2

2-pole contact carrier made of resilient plastic.

CT-E8-2

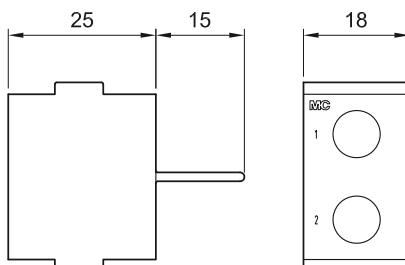

Order No.	Type
33.4000	CT-E8-2

Technical data	
Number of poles	2
For connectors	Coaxial
Pollution degree	2
Limiting temperature (IEC 61984:2008), upper	+90 °C
lower	-40 °C
Contact carrier material	EPTR



Assembly instructions MA213-02

www.staubli.com/electrical

Coaxial connectors

For contact carrier CT-E8-2. Consist of parts of BNC plug connectors. For coaxial cables type RG58¹⁾ and RG59¹⁾.

Type of termination:

Crimp termination (C) of the inner conductor and the shield

Notes:

For the termination of the shield, a brass crimping sleeve is included. The coaxial plug connectors are designed in accordance with CECC 22 120.

CT-B/COAX58



CT-S/COAX58



CT-B/COAX59



CT-S/COAX59

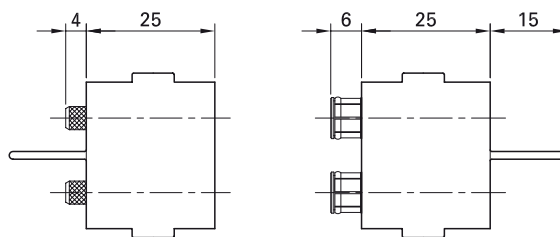

Order No.	Type	Socket	Pin	Inner-Ø crimp sleeve shield	Type of termination
33.0160	CT-B/COAX58	x		5.5 mm	C
33.0560	CT-S/COAX58		x	5.5 mm	C
33.0161	CT-B/COAX59 ²⁾	x		6.5 mm	C
33.0561	CT-S/COAX59 ²⁾		x	6.5 mm	C
33.4050	CT-BS8	Blind plug			

Technical data	
Average sliding force per contact	20 N
Surface inner conductor	CuZn, Au
Surface shield	CuZn, Ni
Voltage standing wave ratio	CT...58: VSWR ≤ 1.25 at f < 1.5 GHz CT...59: VSWR ≤ 1.5 at f < 500 MHz
Rated voltage shield/earth	1000 V, CAT II
Rated voltage inner conductor/shield	1000 V, CAT II
Impedance	CT...58: 50 Ω CT...59: 75 Ω
Voltage level according to	IEC 61010
Mating cycles according to IEC 61169-8	5000 2500

¹⁾ For the coaxial connectors CT-.../COAX58 and CT-.../COAX59, only the coaxial lead RG58 or RG59 is suitable.
²⁾ CT59: if a solid conductor is used, this must be soldered.

100 MBIT, 1 GBIT, 10 GBIT DATA TRANSFER UNIT

1 Gbit module CT-NET-...

Contact carrier made of plastic. One or two 8-pole pin or socket carriers with continuous shielding.

CT-NET-1/B



CT-NET-1/S

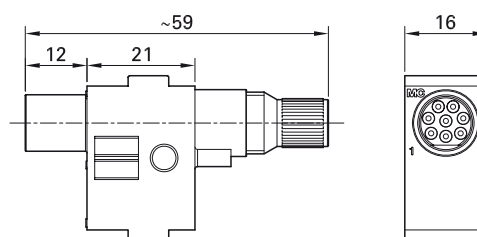

CT-NET-2/B



CT-NET-2/S

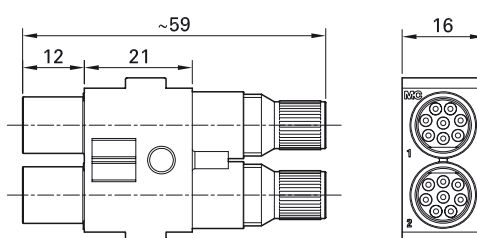

Order No.	Type	Number of contact elements
33.2240	CT-NET-2/B	Depending on contact arrangement on page 47; must be ordered separately
33.2540	CT-NET-2/S	
33.2241	CT-NET-1/B	
33.2641	CT-NET-1/S	

Technical data	
Data transmission	Up to 1 Gbit CAT 5 Ethernet IEEE 802.3 ¹⁾ , Profibus, Profinet, Interbus, CAN-BUS, USB 2.0, PoE ²⁾
Mating cycles	10,000
Limiting temperature (IEC 61984:2008), upper lower	+90 °C -40 °C
Contact carrier material insulation	PA PEEK



Assembly instructions MA213-04

www.staubli.com/electrical

¹⁾ Further technical specifications: www.staubli.com/electrical > Downloads > Technical Info > Industry > Data connectors.

²⁾ According to the IEC 60512-99-001 (100 mating cycles)

Contacts for data transfer in BUS-System CT-NET-...

For contact carrier CT-NET-... Sockets fitted with MULTILAM.

Type of termination:

Crimp termination (C) to a Cu conductor (class 5 and 6)

CT-NET-B...



CT-NET-S...

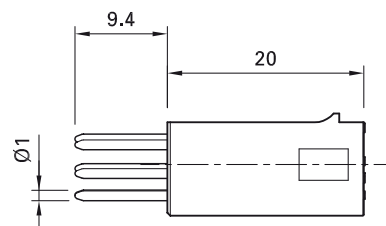
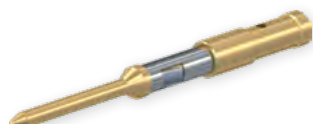

Order No.	Type	Socket	Pin	Surface	Conductor cross section		Rated current	Type of termination
					mm ²	AWG		
33.0148	CT-NET-BP1 ET/0,14-0,75 AU	x			0.14	26	1	C
33.0548	CT-NET-SP1/0,14-0,75 AU		x		0.25	24	2	
					0.34	22	3	
					0.5 ¹⁾	20	3	
					0.75 ¹⁾	18	5	
33.9589	CT-NET-BS ²⁾	Blind plug						

Technical data

Nominal-Ø socket/pin	Ø 1 mm
Average sliding force per connection (8 pins and shield)	10.5 N
Connector resistance	1.8 mΩ
Max. outer diameter per wire	2.3 mm
Maximum outer diameter over the whole cable with special nut CT-NET-MU.PFB; Order No. 13009834 and pliers CT-NET-Z-PFB; Order No. 13009832	7.5 mm 8.5 mm

Contact arrangement of the contact carrier

Left: socket side; right: pin side
(Viewed from the termination side)

CAT5

Ethernet/Profinet

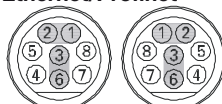

Interbus

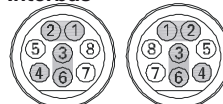

Profibus

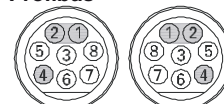

¹⁾ Maximal four wires per connector

²⁾ Unused contact chambers should be closed with blind plugs.



Assembly instructions MA213-04

www.staubli.com/electrical

CAT5e

Ethernet/Profinet

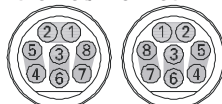

10 Gbit module CT-10GBIT-...

The 10Gbit module is used for Ethernet communication up to 10Gbit/s (CAT6A).

Two versions are available, one for RJ45 and one for M12 (x-coded) connection.

The 10Gbit module is delivered completely assembled.

- Suitable for RJ45 and M12 connection
- 100,000 mating cycles
- UL 1977 and Railway standard compliant
- Resistance to shock (M12) and vibrations (M12, RJ45)

- Applications: high speed data communication, machine-to-machine communication (M2M), real time facility data sharing, railway

CT-10GBIT-RJ45/B



Rear view

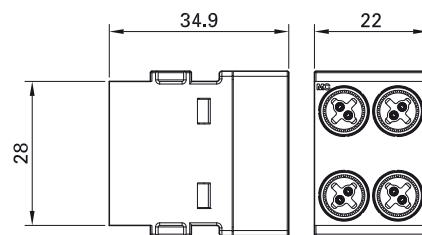
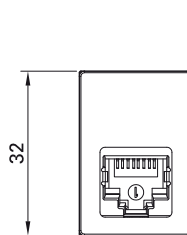

CT-10GBIT-RJ45/S



Rear view

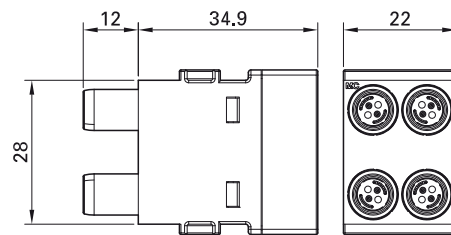
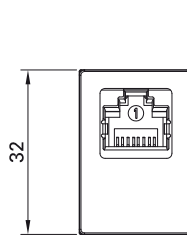

CT-10GBIT-M12/B



Rear view

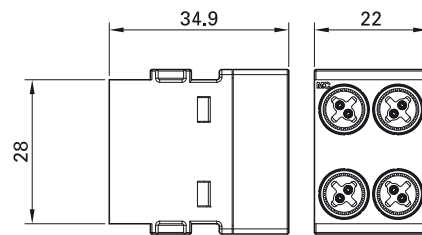
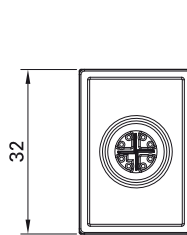

CT-10GBIT-M12/S



Rear view

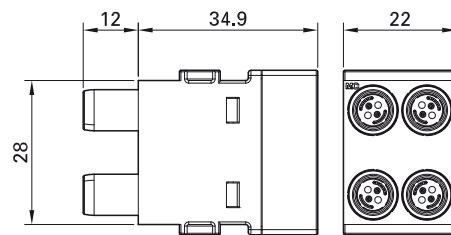
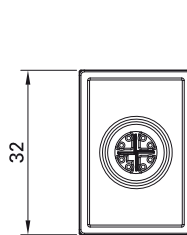

Order No.	Type
33.0130	CT-10GBIT-RJ45/B
33.0530	CT-10GBIT-RJ45/S
33.0240	CT-10GBIT-M12/B
33.0640	CT-10GBIT-M12/S

Technical data	
Data transmission	CAT6A Ethernet IEEE 802.3an, USB 2.0, PoE ¹⁾ with M12
Mating cycles	100,000
Average sliding force per module	14 N
Rated current	0.75 A
Rated voltage ²⁾	48 V
Limiting temperature (IEC 61984:2008), upper lower	+90 °C -40 °C
Contact carrier material	PA
Fire and smoke compliance	EN 45545-2 (HL3 R22 – R23)
Insulation resistance	≥ 500 MΩ
Vibrations, RJ45, M12	5 g/10 – 500 Hz (IEC 60512-6-4) 0.58 g/5 - 150 Hz (IEC 61373:2010 category 1B)
Resistance to shocks, M12	3.06 g/30 ms (IEC 61373:2010 category 1B)

Note:

For the M12 version, refer to the following drawings for cable length in housing (left) and panel mount (right).

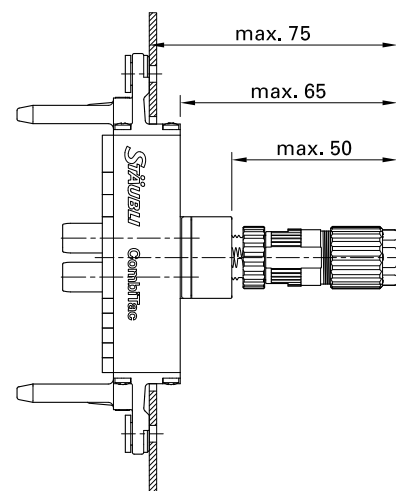
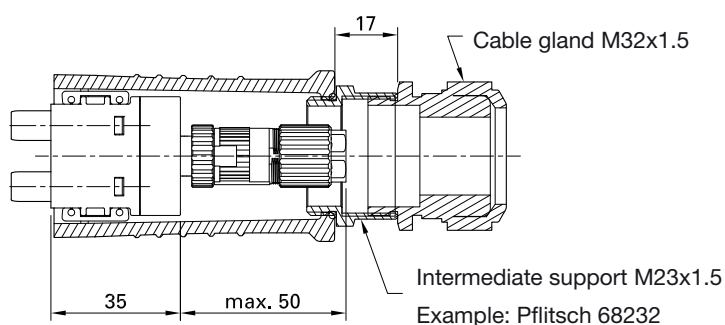

¹⁾ According to the IEC 60512-99-001 (100 mating cycles)

²⁾ Less than DC 30 V for UL 1977. For details on UL see page 138.



Assembly instructions MA213-08

www.staubli.com/electrical



E229145

100 Mbit module CT-RJ45/...

The 100 Mbit module is used for Ethernet communication up to 100 Mbit/s (CAT 5).

Suitable network cables with a RJ45 connectors can be directly connected to the

100 Mbit module. The 100 Mbit module is delivered completely assembled.

CT-RJ45/B



View from rear view

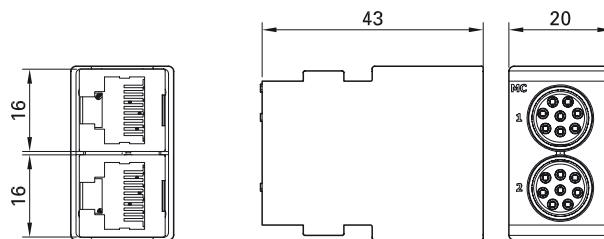

CT-RJ45/S

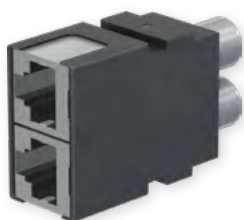

View from rear view

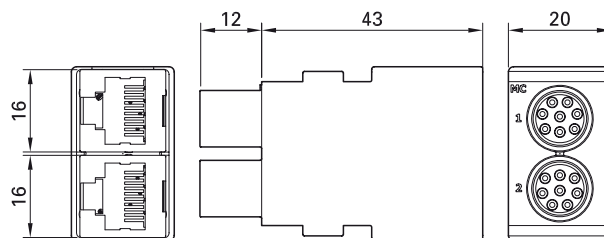

Order No.	Type
33.2169	CT-RJ45/B
33.2170	CT-RJ45/S

Technical data	
Data transmission	CAT 5 Ethernet IEEE 802.3, USB 2.0
Mating cycles	5000
Average sliding force per module (two connections)	19 N
Limiting temperature (IEC 61984:2008), upper	+90 °C
lower	-40 °C
Contact carrier material	PA
Insulation	PEEK
Test voltage 1 min., 50/60 Hz	U _{AC} 500 V

Attenuation characteristics for CT-NET...

Attenuation characteristics for CT-RJ45...

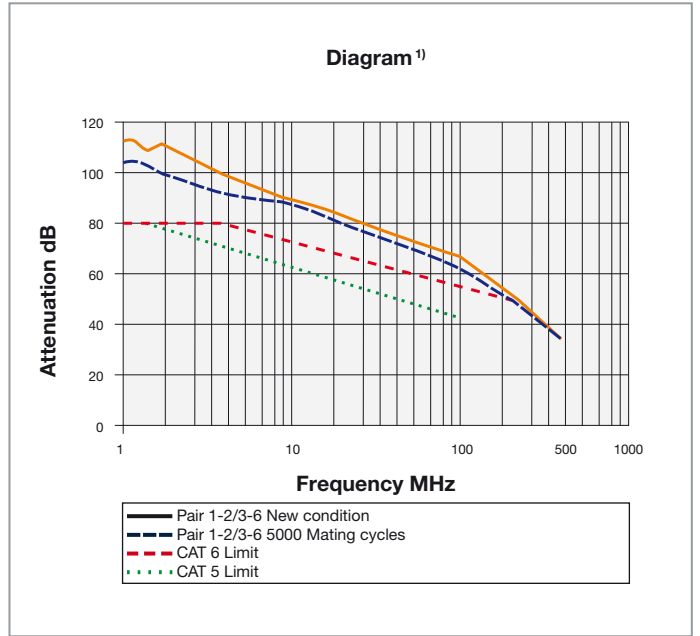
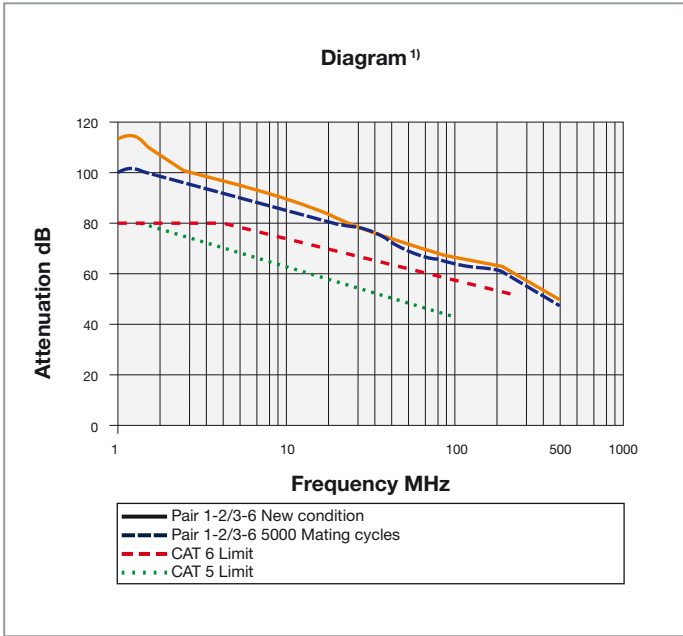

Attenuation characteristics for CT-10GBIT-...

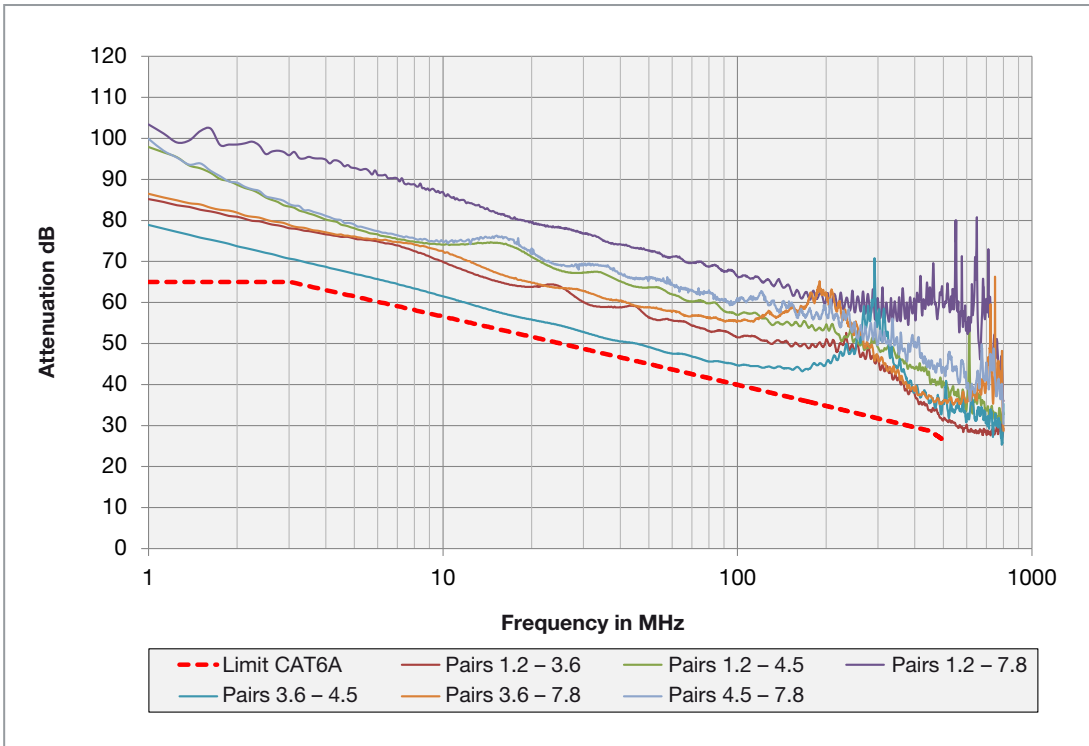

¹⁾ Further technical specifications:
www.staubli.com/electrical > Downloads > Technical Info > Industry > Data connectors.

OPTICAL FIBER UNIT POF

Contact carriers CT-E-3POF/...

3-pole contact carrier made of plastic. Different designs for pins and sockets.

Because of the spring-loaded contacts, the contact carriers must be installed either in a

housing or with a locking system defined by the customer.

CT-E-3POF/B

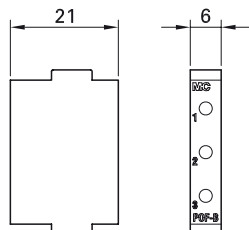

CT-E-3POF/S

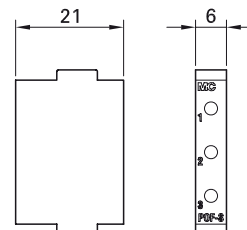

Order No.	Type	Description
33.4016	CT-E-3POF/B	Socket carrier (identification "B")
33.4017	CT-E-3POF/S	Pin carrier (identification "S")

Technical data	
Number of poles	3
For connector type	POF Ø 1 mm
Limiting temperature (IEC 61984:2008), upper	+90 °C
lower	-40 °C ¹⁾
Contact carrier material	PA

Contact carriers CT-E6-2

2-pole contact carrier in plastic for plastic optical fiber with lens, type CT-POF/SL.

CT-E6-2

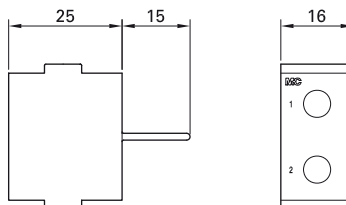

Order No.	Type
33.4006	CT-E6-2

Technical data	
Number of poles	2
For connector type	POF Ø 1 mm
Limiting temperature (IEC 61984:2008), upper	+90 °C
lower	-40 °C ¹⁾
Contact carrier material	EPTR

¹⁾ Check the temperature ratings of the optical fiber



Assembly instructions MA213-03

www.staubli.com/electrical

Plastic optical fiber contacts CT-.../POF

For the connection of plastic optical fiber cables of the type POF Multimode. Standard version or lens version.

Advantages of lens version CT-POF/SL:

- Higher tolerance against dirt
- Easy to clean
- Same type for both mating sides
- Higher number of mating cycles

Note:

Cleaning the contact surface at regular intervals (depending on the environment) assure a constant attenuation value.

CT-B/POF



CT-S/POF



CT-POF/SL

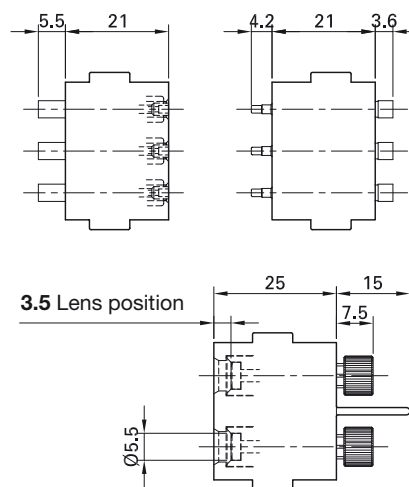

Order No.	Type	Socket	Pin	For contact carrier
33.0170	CT-B/POF	x		CT-E-3POF/B
33.0570	CT-S/POF		x	CT-E-3POF/S
33.0370	CT-POF/SL	x	x	CT-E6-2

Technical data	
Ø of core/cladding	980/1000 µm
Ø of first protective covering	2200 µm
Insertion loss CT-B/POF, CT-S/POF	< 3 dB at 650 nm, depending on assembly type
Bandwidth length product MHz	1 km at 650 nm
Numeric aperture	0.47
Insertion loss of the complete connector CT-POF/SL	< 6 dB at 650 nm
Mating cycles CT-POF	500
CT-POF/SL	100,000
Max. sliding force CT-POF	6 N
CT-POF/SL	0 N



Assembly instructions MA213-03

www.staubli.com/electrical

OPTICAL FIBER UNIT GOF

Contact carrier CT-E-4GOF

4-pole contact carrier made of plastic.

CT-E-4GOF

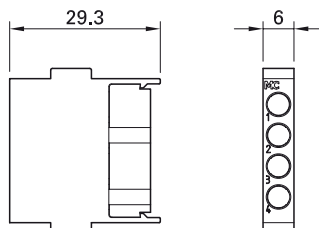

Order No.	Type
33.4065	CT-E-4GOF

Technical data	
Contact carrier material	PA

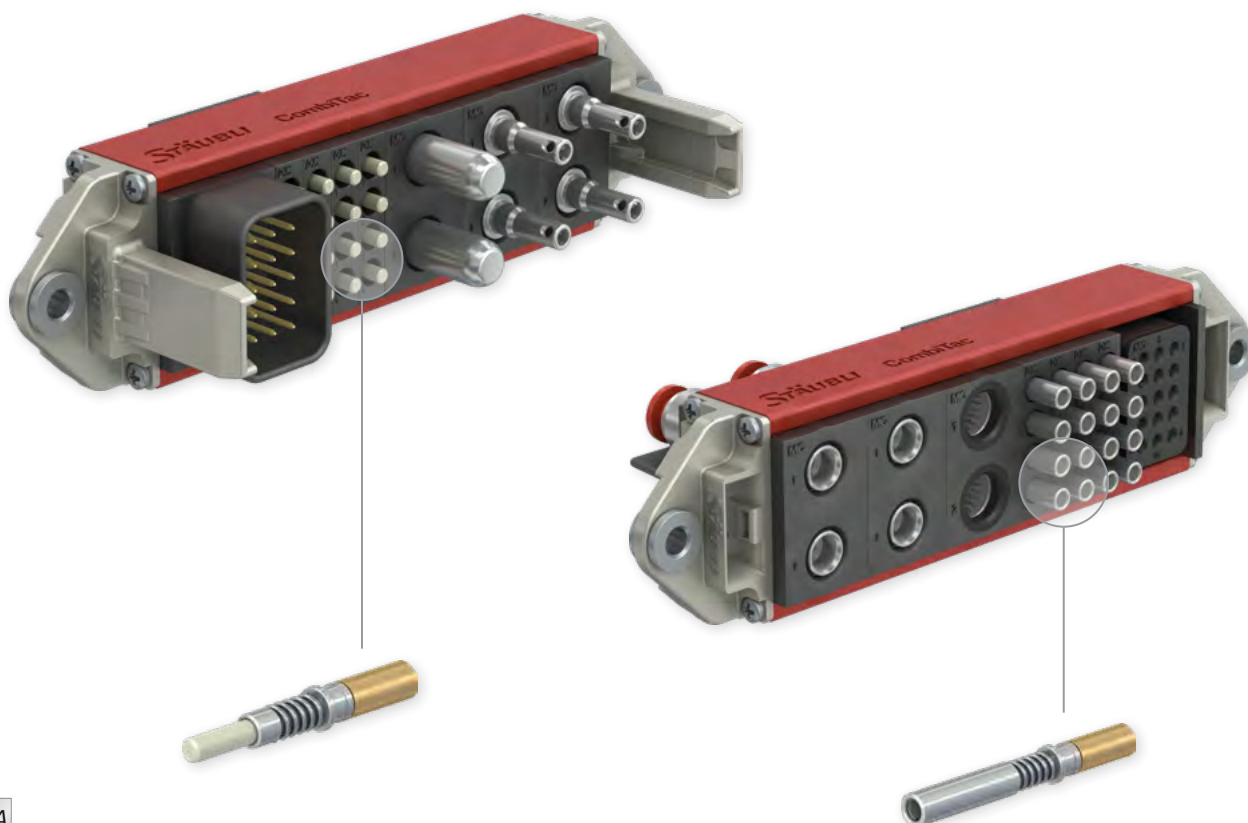

Assembly instructions MA213-06, MA092

www.staubli.com/electrical

Glass optical fiber contacts CT-.../GOF

For the connection of glass optical fiber cables of the type Multimode to fit contact carrier CT-E-4GOF.

In preassembled cables, one end is equipped with ST, SC or FSMA plug connectors according to choice. The cable length

is 1 m or 0.3 m for FSMA pin. Fiber type: Graded-index multimode fiber 50/125 μm . Cable diameter: 3 mm.

CT-B/GOF



CT-S/GOF



Socket side

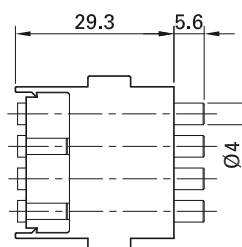

Pin side

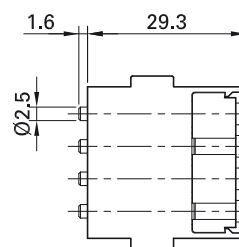

CT-B/GOF-100-ST

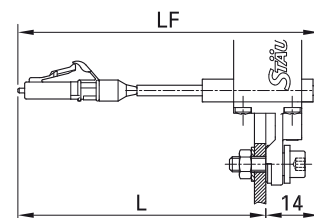
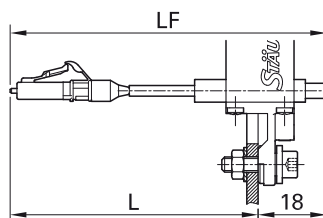

Order No.	Type	Socket	Pin	Designation	on tail end preassembled with
33.0171	CT-B/GOF	x		Contact for multimode fiber	
33.0571	CT-S/GOF		x	Contact for multimode fiber	
33.0171-100	CT-B/GOF-100-ST ¹⁾	x		1 m Preassembled multimode cable	ST
33.0571-100	CT-S/GOF-100-ST ¹⁾		x	1 m Preassembled multimode cable	ST
33.0172-100	CT-B/GOF-100-SC ¹⁾	x		1 m Preassembled multimode cable	SC
33.0572-100	CT-S/GOF-100-SC ¹⁾		x	1 m Preassembled multimode cable	SC
33.0228-100	CT-B/GOF-100-FSMA	x		1 m Preassembled multimode cable	FSMA
33.0628-030	CT-S/GOF-030-FSMA		x	0.3 m Preassembled multimode cable	FSMA
33.4080	CT-BSGOF	Blind plug			

Technical data

Insertion loss	<0.5 dB at 850/1300 nm, depending on assembly type
Mating cycles	≥ 500 (cleaning interval every 100 mating cycles) ²⁾
Spring deflection	3 mm
Contact pressure	10 N per contact with 3 mm spring deflection
Allowable operating temperature IEC 60794-1-2 F1	-10 °C ... +70 °C for pre-assembled contacts

Fiber types

Multimode fiber	50/125 μm , 62.5/125 μm
Coating diameter	250/900 μm
Ø of cable	3 mm



Assembly instructions MA213-06, MA092

www.staubli.com/electrical

LF= total length.

L = length from CombiTac mounting position.

¹⁾ Other cable lengths and connectors type (LC, ...) on request.
Specify L or LF length.

²⁾ Note: Cleaning the contact surface at regular intervals (depending on the environment) assures a constant attenuation value and increases the number of mating cycles.

THERMOCOUPLE UNIT

Thermocouple pressure contacts

Thermocouple allows for the precise measurement of temperatures. Between two wires of different materials a voltage is generated that varies according to the rise in temperature.

The electrical measurement of temperature requires that the entire measurement chain (temperature sensor, cable connection points) consists of the same combination of materials. Using a uniform material pre-

vents thermal imbalances in the case of the connection of two parts with the same initial temperature.

With Stäubli thermocouple contacts, you can extend the measurement chains or lay them out as plug contact connections.

There are several types of thermocouples made from different materials adapted to the measured temperature range.

Stäubli thermocouple pressure contacts are available for 5 different types of sensor: E, J, K, N, and T. For that reason, Stäubli has developed different types of spring loaded contacts for thermocouples from the 7 most commonly used alloys: NiCr, NiAl, NiCrSi, NiSi, CuNi, Fe, Cu.

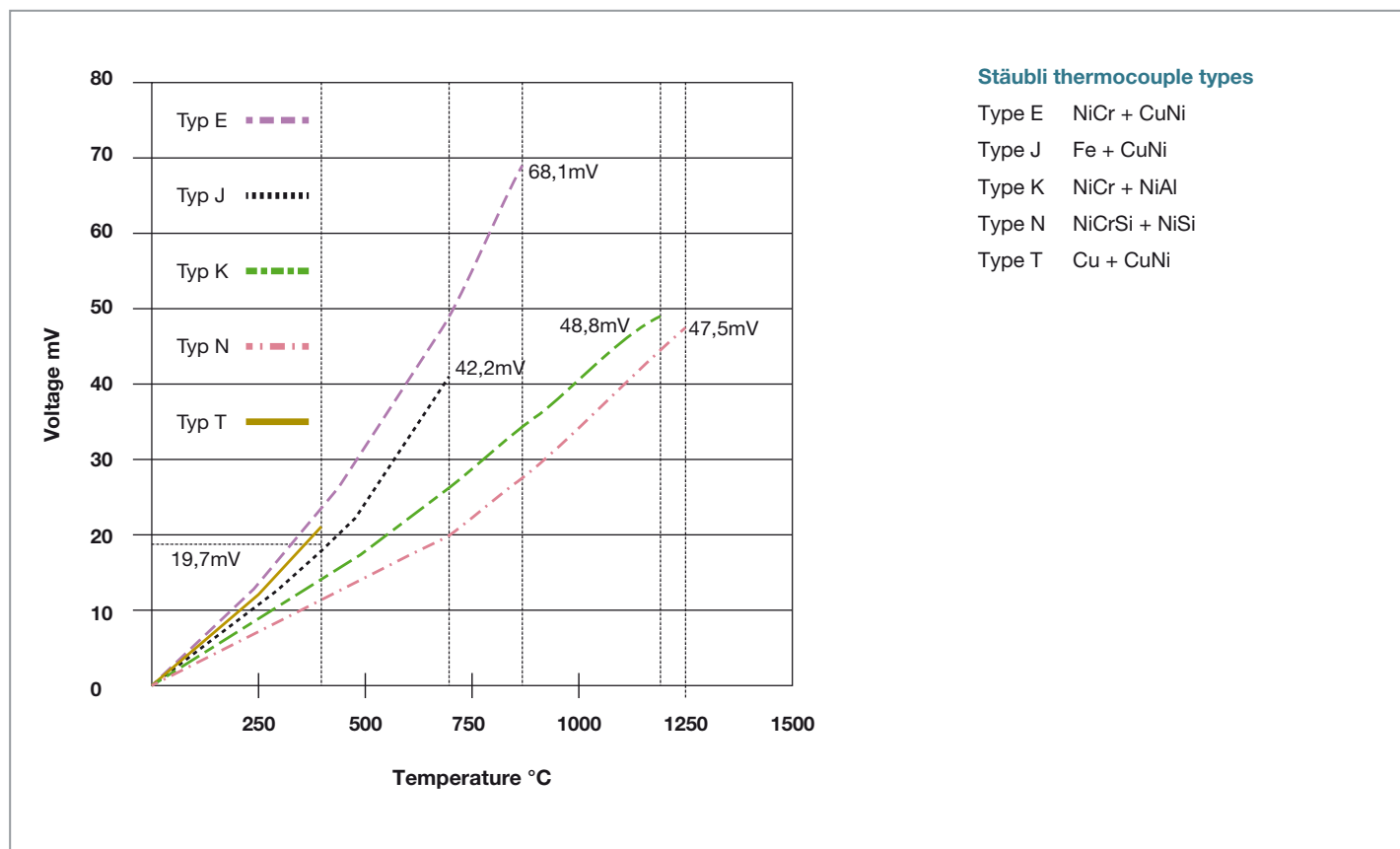

Description according to: IEC 60584-1

To ensure clear identification, our spring-loaded thermocouple contacts are provided with different grooves and markings:

Cu
Copper (without groove)



Fe
Iron (without groove)



NiAl
Alumel® (1 groove)



NiCr
Chromel® (2 grooves)



NiSi
Nisil (3 grooves)



NiCrSi
Nicrosil (4 grooves)



CuNi
Constantan® (1 wide groove)



Material marking

Groove

Contact carrier CT-E-2TH+PE/...

3-pole contact carrier made of plastic. For two thermocouple pressure contacts and one PE contact.

Different designs for pins and sockets. Because of the spring-loaded contacts, the contact carriers must be installed either in

a housing or with a locking system defined by the customer.

CT-E-2TH+PE/B

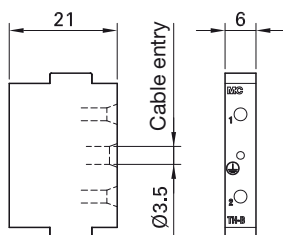

CT-E-2TH+PE/S

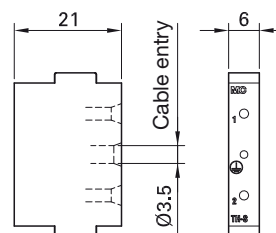

Order No.	Type	Description
33.4011	CT-E-2TH+PE/B	Socket carrier (identification "B")
33.4012	CT-E-2TH+PE/S	Pin carrier (identification "S")

Technical data

Number of poles	1 thermocouple (2 contacts)/1 PE
Contact carrier material	EPTR



Assembly instructions MA213-01

www.staubli.com/electrical

Thermocouple pressure contacts

For the connection of measurement chains for thermocouple, for contact carriers CT-E-2TH+PE/...

Type of termination:

Crimp termination

Note:

Soldering is not permitted, meaning that only uniform materials are used. **This ensures a homogeneous measurement chain.**

DBP2-...

DSP2-...

CT-BP1,5LAV/0,5-1,5 AU

CT-SP1,5/0,5-1,5K AU

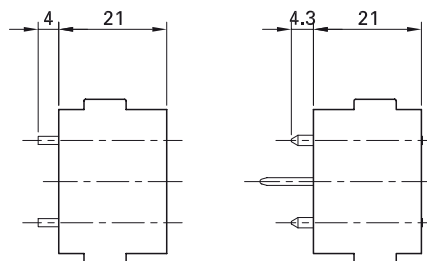

Order No.	Type	Socket	Pin	Material	Material marking	Groove marking	PE contact	Crimp termination	
19.6724	DBP2-NISI/0,14-0,5	x		NiSi	NIS				
19.6723	DSP2-NISI/0,14-0,5		x	NiSi	NIS				
19.6722	DBP2-NICRSI/0,14-0,5	x		NiCrSi	NIC				
19.6721	DSP2-NICRSI/0,14-0,5		x	NiCrSi	NIC				
19.6726	DBP2-CU/0,14-0,5	x		Cu	CU				
19.6725	DSP2-CU/0,14-0,5		x	Cu	CU				
19.6720	DBP2-FE/0,14-0,5	x		Fe	FE				
19.6719	DSP2-FE/0,14-0,5		x	Fe	FE				
19.6718	DBP2-CO/0,14-0,5	x		CuNi	CO				
19.6717	DSP2-CO/0,14-0,5		x	CuNi	CO				
18.8062	DBP2-AL/0,14-0,5	x		NiAl	AL				
18.9062	DSP2-AL/0,14-0,5		x	NiAl	AL				
18.8063	DBP2-CR/0,14-0,5	x		NiCr	CR				
18.9063	DSP2-CR/0,14-0,5		x	NiCr	CR				
33.0153	CT-BP1,5LAV/0,5-1,5 AU	x		CuZn, Au			x		
33.0550	CT-SP1,5/0,5-1,5K AU		x	CuZn, Au			x		
18.5504	MVS1	Blind plug							

Technical data	
For conductor cross section	0.14 mm ² – 0.5 mm ² ¹⁾
Contact pressure (spring insertion 1 mm)	6 – 9 N
Mating cycles	100,000 ²⁾



Assembly instructions MA213-01

www.staubli.com/electrical

¹⁾ Contacts for conductor cross section 0.5 mm² – 1 mm² on request.

²⁾ Maintenance interval: every 10,000 or 50,000 cycles depending on thermocouple type, see MA213.

PNEUMATIC AND FLUID UNITS

Compressed air and vacuum modules

RCT 03:

- Nominal width: 3 mm
- With shut-off on one side or without shut-off valve

RCT 06:

- Nominal width: 6 mm
- With shut-off on one side or without shut-off valve

UCT:

- Nominal widths: 4 mm, 6 mm, and 8 mm
- Without shut-off valve

RCT



UCT



Coolant modules

- Nominal widths: 3 mm, 5 mm and 6 mm
- Leakproof rapid couplings
- With shut-off on both sides
- LCT06 suitable for panel mount and housing applications

SCT

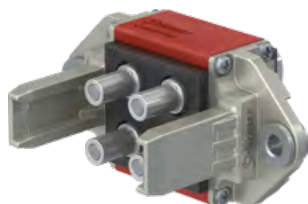

LCT



The compressed air and coolant couplers are supplied ready mounted in the carrier. Stainless steel options are also available. FDA versions available in stainless steel with JE seals (lubricants and seals used are in compliance with the FDA requirements).

Sealings for coolant modules

Several sealing options are available in addition to the standard Nitrile (NBR) seal (page 61).

The seal material selected depends on the fluid carried, the working temperature and the maximum working pressure. Please do not hesitate to contact our technician for advice. Our experience as a quick-release coupling specialist is at your disposal.

Sealing material	Code	Minimum and maximum allowable temperatures TS (°C)	Applications
Nitrile (NBR)	NBR (standard)	-15 °C and +100 °C	<ul style="list-style-type: none"> • General applications • High mechanical strength
Fluorocarbon (FPM)	JV	-10 °C and +200 °C	<ul style="list-style-type: none"> • Good chemical resistance • Outstanding resistance to high temperatures up to 200 °C • Resistance to mineral oils, synthetic hydraulic oils, fuels, chemicals, hydrocarbons and coolants
Ethylene-propylene (EPDM)	JE	-20 °C and +150 °C	<ul style="list-style-type: none"> • Excellent resistance to high temperatures • Compatible with phosphate – based brake fluids – esters, hot and cold water, steam
Perfluoroelastomer (FFKM)	JK	0 °C and +250 °C	<ul style="list-style-type: none"> • Combines the qualities of an elastomer with the chemical resistance of PTFE • Remarkable resistance to heat and most chemical agents • Coolants
Fluorosilicone (FMQ)	JS3	-45 °C and +175 °C	<ul style="list-style-type: none"> • Good resistance to low and high temperatures • Resistance to mineral oils, fuels

The general temperature ranges of the CombiTac must be respected regardless of the temperature specifications of the seals.

7 different sizes of carriers

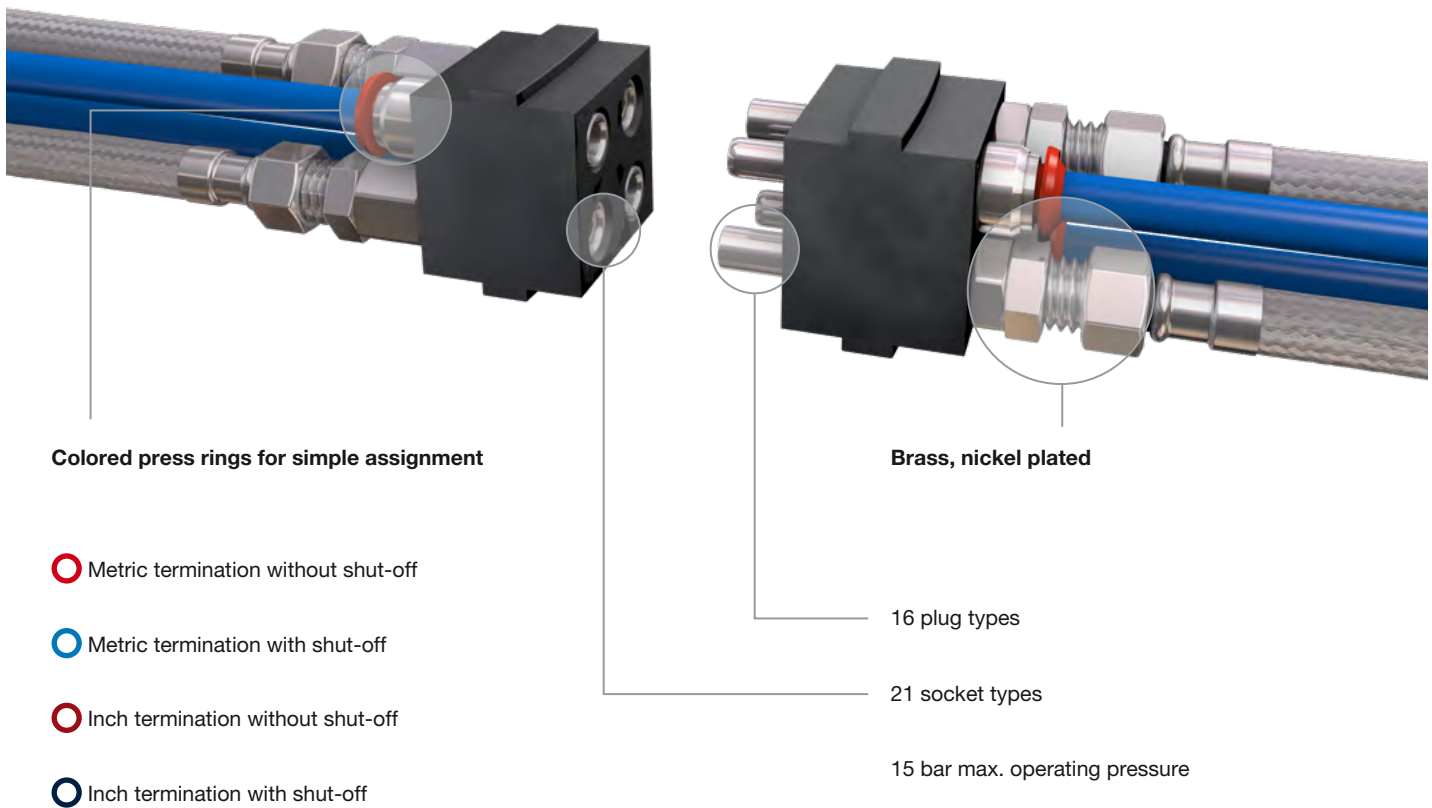

Recommended calibrated plastic tubes:
TUBANE Stäubli (PU) / RILFLEX Stäubli (PA)
See catalog "Tuyaux flexibles (flexible hoses)" from Stäubli

COMPRESSED AIR – VACUUM UNIT

Carriers for compressed air and coolant couplings CT-E8...

2- and 4-pole carriers made of resilient plastic.

CT-E8-2

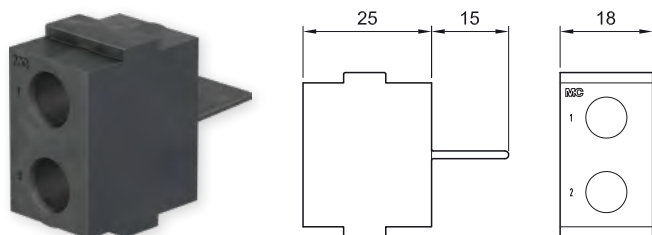

CT-E8-4/B

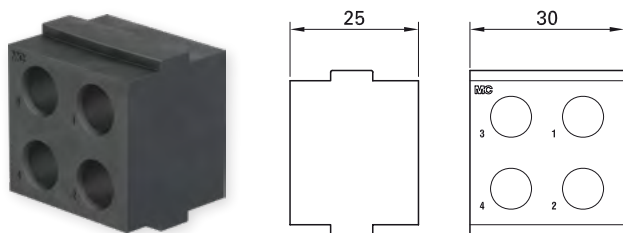

CT-E8-4/S

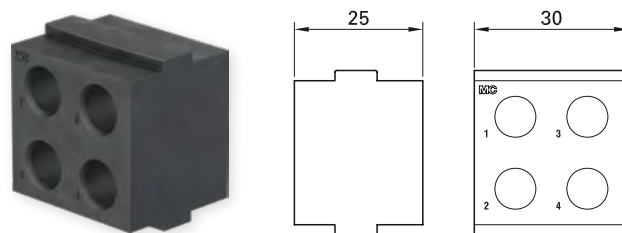

Order No.	Type	Number of poles	For sockets	For plugs
33.4000	CT-E8-2	2	x	x
33.4024	CT-E8-4/B	4	x	
33.4027	CT-E8-4/S	4		x

Technical data

Contact carrier material EPTR

Technical data from page 63:

Technical data

	RCT03	UCT04
Nominal bore (mm)	03	04
Max. working pressure (bar)	15	
Min. working pressure (mbar)	14	
Operating temperatures	-15 °C ... +90 °C	
Sealing materials	NBR	
Mating cycles	100,000 ²⁾	

Compressed air couplings CT-...-RCT03/... and CT-...-UCT04/...

For carriers CT-E8...

Type of termination:

Clamping and PLV screw connection for calibrated plastic tubes (PA or PU)

CT-B...-RCT03/...



CT-S...-RCT03/...



CT-B-UCT04/...



CT-S-UCT04/...



CT-BV-RCT03/PLV...



CT-S-RCT03/PLV...

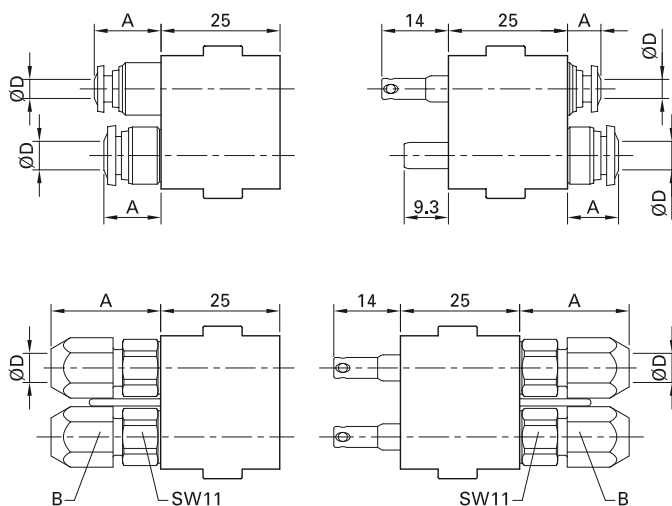

Order No.	Type	Socket	Plug	Outer-Ø D of the tube		A	B (SW)	Shut-off		Press ring color
				mm	"			Without	With	
33.0180	CT-B-RCT03/4	x		4	(5/32)	14		x		●
33.0181	CT-BV-RCT03/4	x		4	(5/32)	14			x	●
33.0580	CT-S-RCT03/4		x	4	(5/32)	7		x		●
33.0182	CT-B-RCT03/6 ¹⁾	x		6		17		x		●
33.0183	CT-BV-RCT03/6 ¹⁾	x		6		17			x	●
33.0582	CT-S-RCT03/6 ¹⁾		x	6		11.5		x		●
33.0184	CT-B-RCT03/1/4"	x			1/4	17		x		●
33.0185	CT-BV-RCT03/1/4"	x			1/4	17			x	●
33.0584	CT-S-RCT03/1/4"		x		1/4	11.5		x		●
33.0175	CT-B-RCT03/PLV4/6	x		6		23	11	x		
33.0179	CT-BV-RCT03/PLV4/6	x		6		23	11		x	
33.0578	CT-S-RCT03/PLV4/6		x	6		23	11	x		
33.0275	CT-B-RCT03/PLV 2/4	x		4		20	8	x		
33.0279	CT-BV-RCT03/PLV 2/4	x		4		20	8		x	
33.0675	CT-S-RCT03/PLV 2/4		x	4		20	8	x		
33.0186	CT-B-UCT04/6 ¹⁾	x		6		12		x		●
33.0586	CT-S-UCT04/6 ¹⁾		x	6		10.7		x		●
33.0188	CT-B-UCT04/1/4"	x			1/4	12		x		●
33.0588	CT-S-UCT04/1/4"		x		1/4	10.7		x		●

¹⁾ For flow, head loss diagrams, and sliding forces, see page 132.

²⁾ Lubrication interval every 20,000 mating cycles, see MA213.

Carriers for compressed air couplings CT-E-UCT06-...

1-, 2-, or 4-pole carrier made of resilient plastic.

Note:

The contact carrier can be used on both the socket and the pin side. The difference shows in the position of the MC logo.

CT-E-UCT06-1



Socket side

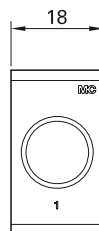

Pin side

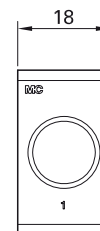

CT-E-UCT06-2



Socket side

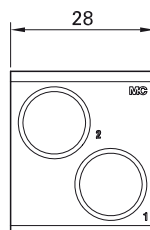

Pin side

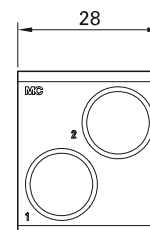

CT-E-UCT06-4



Socket side

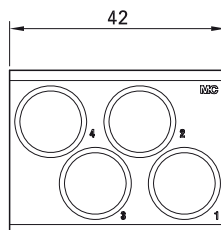

Pin side

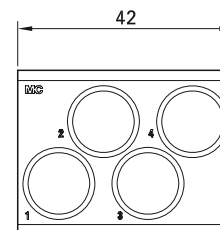

Order No.	Type	Number of poles	For sockets	For plugs
33.4028	CT-E-UCT06-1	1	x	x
33.4029	CT-E-UCT06-2	2	x	x
33.4030	CT-E-UCT06-4	4	x	x

Technical data

Contact carrier material

EPTR

Compressed air couplings CT-...-UCT06/8

For carriers CT-E-UCT06-...

Type of termination:

Clamping termination for calibrated plastic tubes (PA or PU)

CT-B-UCT06/8



CT-S-UCT06/8

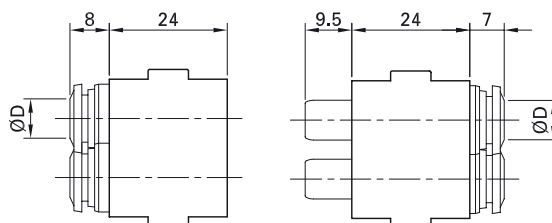

Order No.	Type	Socket	Plug	Outer-Ø D of the tube		Shut-off		Press ring color
				mm	"	Without	With	
33.0190	CT-B-UCT06/8 ¹⁾	x		8	(5/16)	x		
33.0590	CT-S-UCT06/8 ¹⁾		x	8	(5/16)	x		

Technical data	
Nominal bore (mm)	06
Max. working pressure (bar)	15
Min. working pressure (mbar)	14
Operating temperatures	-15 °C ... +90 °C
Sealing materials	NBR
Mating cycles	100,000 ²⁾

¹⁾ For flow, head loss diagrams, and sliding forces, see page 133.

²⁾ Lubrication interval every 20,000 mating cycles, see MA213.

Carriers for compressed air couplings CT-E-UCT08-...

1- or 2-pole contact carrier made of resilient plastic.

Note:

The contact carrier can be used on both the socket and the pin side. The difference can be seen in the position of the MC logo.

CT-E-UCT08-1



Socket side

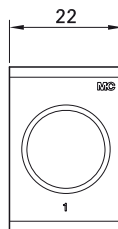

Pin side

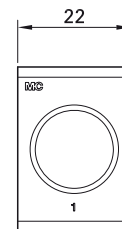

CT-E-UCT08-2



Socket side

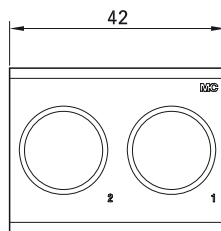

Pin side

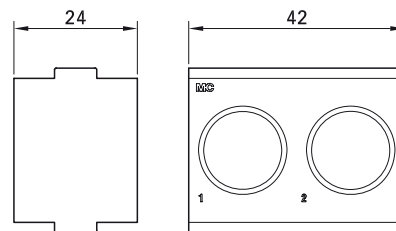

Order No.	Type	Number of poles	For sockets	For plugs
33.4032	CT-E-UCT08-1	1	x	x
33.4031	CT-E-UCT08-2	2	x	x

Technical data

Contact carrier material EPTR

Technical data from page 67:

Technical data

	RCT06	UCT08
Nominal bore (mm)	06	08
Max. working pressure (bar)	15	
Min. working pressure (mbar)	14	
Operating temperatures	-15 °C ... +90 °C	
Sealing materials	NBR	
Mating cycles	100,000 ¹⁾	

¹⁾ Lubrication interval every 20,000 mating cycles, see MA213.

Compressed air couplings CT-...-UCT08... and CT-...-RCT06/...

For carriers CT-E-UCT08-...

Type of termination:

Clamping and PLV screw termination for calibrated plastic tubes (PA or PU)

CT-BV-RCT06/8



CT-S-RCT06/8

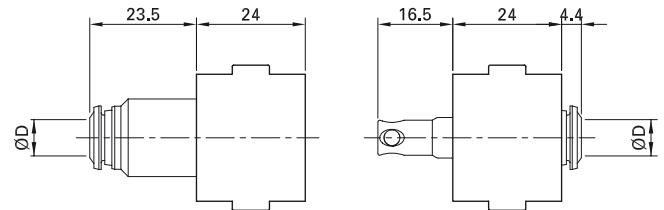

CT-B-UCT08/10



CT-S-UCT08/10

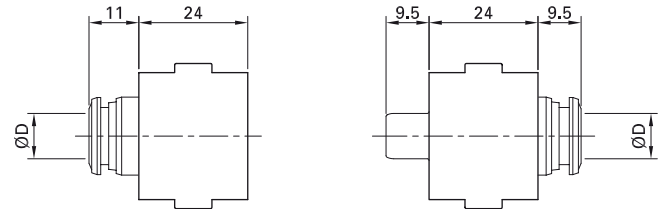

CT-BV-RCT06/PLV6/8



CT-S-RCT06/PLV6/8

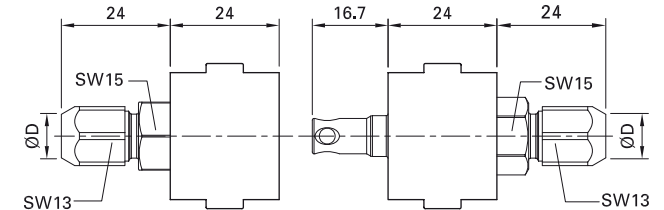

CT-BV-RCT06/PLV8/10



CT-S-RCT06/PLV8/10

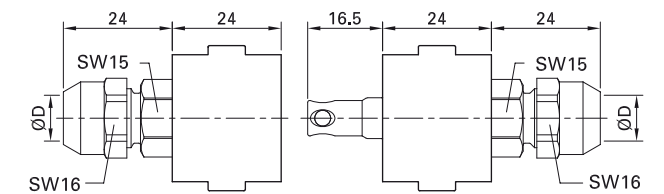

Order No.	Type	Socket	Plug	Outer-Ø D of the tube		A	Shut-off		Press ring color
				mm	"		without	with	
33.0201	CT-BV-RCT06/8	x		8	(5/16)			x	
33.0601	CT-S-RCT06/8		x	8	(5/16)		x		
33.0176	CT-BV-RCT06/PLV6/8	x		8			x	x	
33.0576	CT-S-RCT06/PLV6/8		x	8			x		
33.0177	CT-BV-RCT06/PLV8/10	x		10			x	x	
33.0577	CT-S-RCT06/PLV8/10		x	10			x		
33.0194	CT-B-UCT08/10 ¹⁾	x		10			x		
33.0594	CT-S-UCT08/10 ¹⁾		x	10			x		
33.0196	CT-B-UCT08/3/8"	x			3/8		x		
33.0596	CT-S-UCT08/3/8"		x		3/8		x		

¹⁾ For flow, head loss diagrams, and sliding forces, see page 133.

Carriers for coolants couplings CT-E8...

2- and 4-pole carrier made of resilient plastic.

CT-E8-2

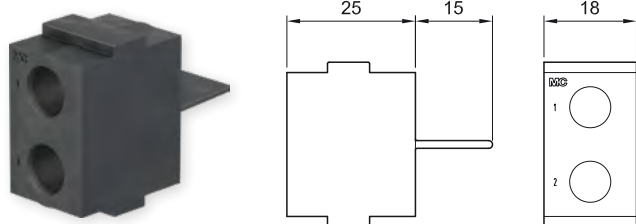

CT-E-SCT03-2

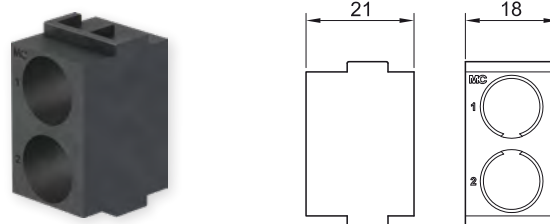

CT-E8-4/B

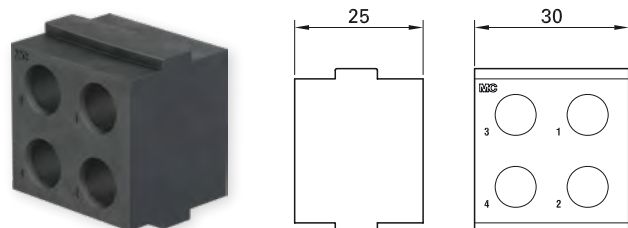

CT-E8-4/S

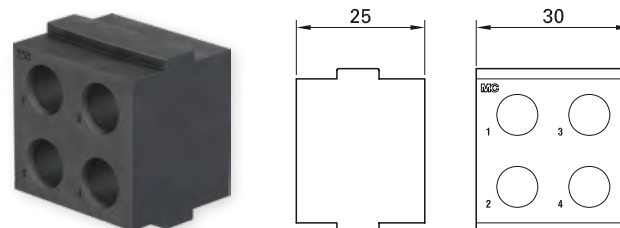

Order No.	Type	Number of poles	For sockets	For plugs
33.4000	CT-E8-2	2	×	×
33.4024	CT-E8-4/B	4	×	
33.4027	CT-E8-4/S	4		×
33.4077	CT-E-SCT03-2	2	×	×

Technical data

Contact carrier material | EPTR

Coolants couplings CT-...-SCT03

For carriers CT-E8..., leakproof, shut-off on both sides

Type of termination:
Internal thread¹⁾

CT-B-SCT03



CT-S-SCT03

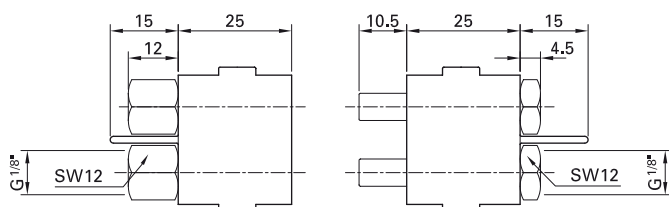

					Shut-off
Order No.	Type	Socket	Plug	Outer-Ø D of the tube	Leakproof
				"	
33.0198	CT-B-SCT03 ²⁾	x		G 1/8	x
33.0598	CT-S-SCT03 ²⁾		x	G 1/8	x

Technical data	
Nominal bore (mm)	03
Max. working pressure (bar)	15
Min. working pressure (mbar)	14
Spring force (permanent)	43 N without pressure
Operating temperatures	-15 °C ... +90 °C
Sealing materials	NBR
Mating cycles	100,000 ³⁾

¹⁾ Recommended a torque of 15 N m, cylindrical thread and O-Ring seal

²⁾ For flow, head loss diagrams, and sliding forces, see page 134.

³⁾ Lubrication interval every 20,000 mating cycles, see MA213.

Carriers for coolants couplings CT-E-UCT08-...

1- and 2-pole carriers made of resilient plastic.

Note:

The contact carrier can be used on both the socket and the pin side. The difference can be seen in the position of the MC logo.

CT-E-UCT08-1



Socket side

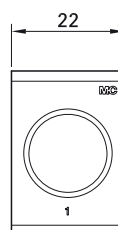

Pin side

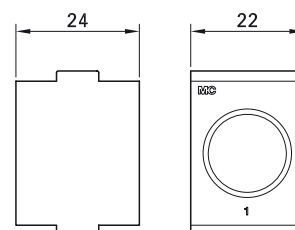

CT-E-UCT08-2



Socket side

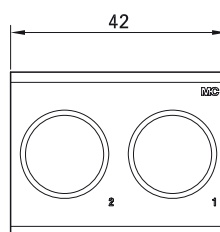

Pin side

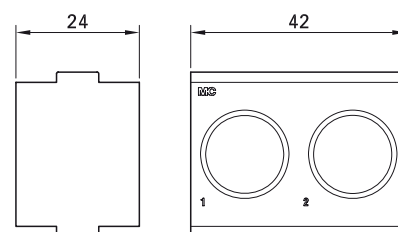

Order No.	Type	Number of poles	For sockets	For plugs
33.4032	CT-E-UCT08-1	1	x	x
33.4031	CT-E-UCT08-2	2	x	x

Technical data

Contact carrier material EPTR

Coolants couplings CT-...-SCT05

For carrier CT-E-UCT08-..., leakproof, shut-off on both sides

Type of termination:

Internal thread¹⁾

Note:

Not suited for use in DIN housings. Due to the long stroke of the SCT05 coupling, two movements (push and lock) are required to connect the DIN housing.

CT-B-SCT05



CT-S-SCT05

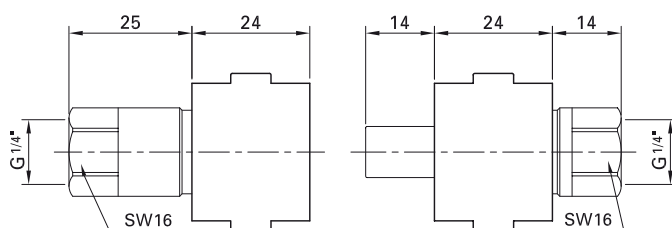

Order No.	Type	Socket	Plug	Outer-Ø D of the tube		A	Shut-off
				mm	"		With
33.0199	CT-B-SCT05 ²⁾	x		8	G (1/4)		x
33.0599	CT-S-SCT05 ²⁾		x	8	G (1/4)		x

Technical data	
Nominal bore (mm)	05
Max. working pressure (bar)	15
Min. working pressure (mbar)	14
Spring force (permanent)	60 N without pressure
Operating temperatures	-15 °C ... +90 °C
Sealing materials	NBR
Mating cycles	100,000 ³⁾

Note

Observe page 138 :
Electrical plug connectors for control and power in the immediate proximity of connections for liquids and gas.

¹⁾ Recommended a torque of 15 N m, cylindrical thread and O-Ring seal

²⁾ For flow, head loss diagrams, and sliding forces, see page 134.

³⁾ Lubrication interval every 20,000 mating cycles, see MA213..

Carriers for coolants couplings CT-E-UCT08-...

1- and 2-pole carriers made of resilient plastic.

Note:

The contact carrier can be used on both the socket and the pin side. The difference can be seen in the position of the MC logo.

CT-E-UCT08-1



Socket side

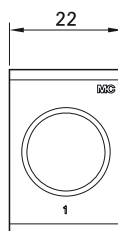

Pin side

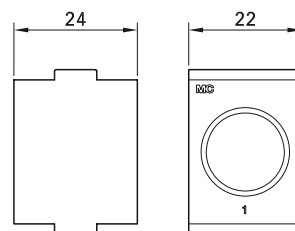

CT-E-UCT08-2



Socket side

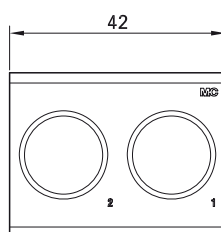

Pin side

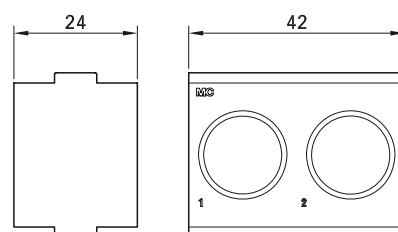

Order No.	Type	Number of poles	For sockets	For plugs
33.4032	CT-E-UCT08-1	1	×	×
33.4031	CT-E-UCT08-2	2	×	×

Technical data

Contact carrier material | EPTR

Coolants couplings CT-...-LCT06

For carrier CT-E-UCT08-..., leakproof, shut-off on both sides

Type of termination:
Internal thread

Note:

- CT-...-LCT06 suitable for panel and housing applications.

CT-B-LCT06



CT-S-LCT06

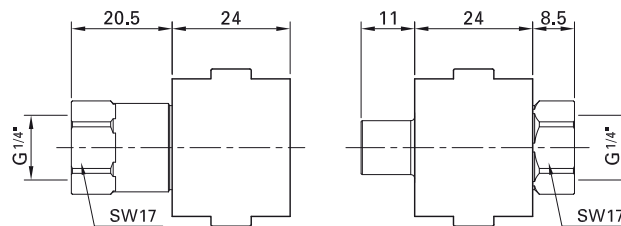

Order No.	Type	Socket	Plug	Outer-Ø D of the tube		A	Shut-off
				mm	"		With
33.0229	CT-B-LCT06 ¹⁾	x		8	G 1/4		x
33.0629	CT-S-LCT06 ¹⁾		x	8	G 1/4		x

Technical data	
Nominal bore (mm)	06
Max. working pressure (bar)	15
Min. vacuum absolute pressure (mbar)	14
Spring force (permanent)	44.5 N without pressure
Counter force while mated	135 N/10 bar; 187 N/15 bar
Operating temperatures	-15 °C ... +90 °C
Sealing materials	NBR
Mating cycles	100,000 ²⁾

Note

Observe page 138 :
Electrical plug connectors for control and power in the immediate proximity of connections for liquids and gas.

¹⁾ For flow, head loss diagrams, and sliding forces, see page 135.

²⁾ Lubrication interval every 20,000 mating cycles, see MA213.

SPACERS

Spacers

To fill gaps in the CombiTac or for connection coding.

CT-DIP...

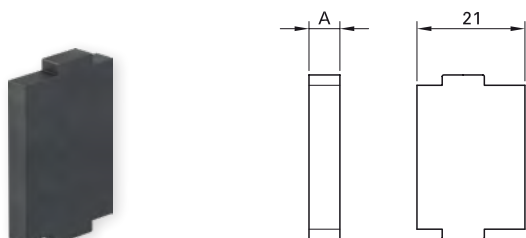

CT-DIP.../2

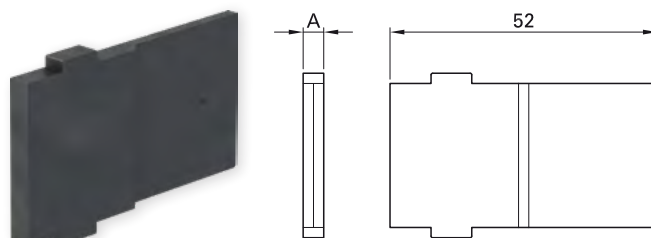

Order No.	Type	Size A
33.4097	CT-DIP0,5	0.5 mm
33.4043	CT-DIP1	1 mm
33.4040	CT-DIP2	2 mm
33.4041	CT-DIP3	3 mm
33.4042	CT-DIP4	4 mm
33.4085	CT-DIP4/2	4 mm

Technical data

Contact carrier material, CT-DIP0,5; CT-DIP4/2	PA
CT-DIP1; CT-DIP2; CT-DIP3; CT-DIP2	EPTR

Gaps filled with **spacers** in a CombiTac mounted in a DIN housing (pictures above). If the contacts are arranged symmetrically,

the possibility of pole reversal exists. With the help of spacers, a **connection coding** can be realized (pictures below).



Spacers

Connection coding

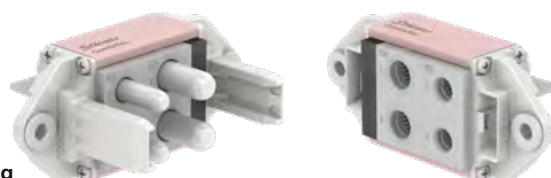

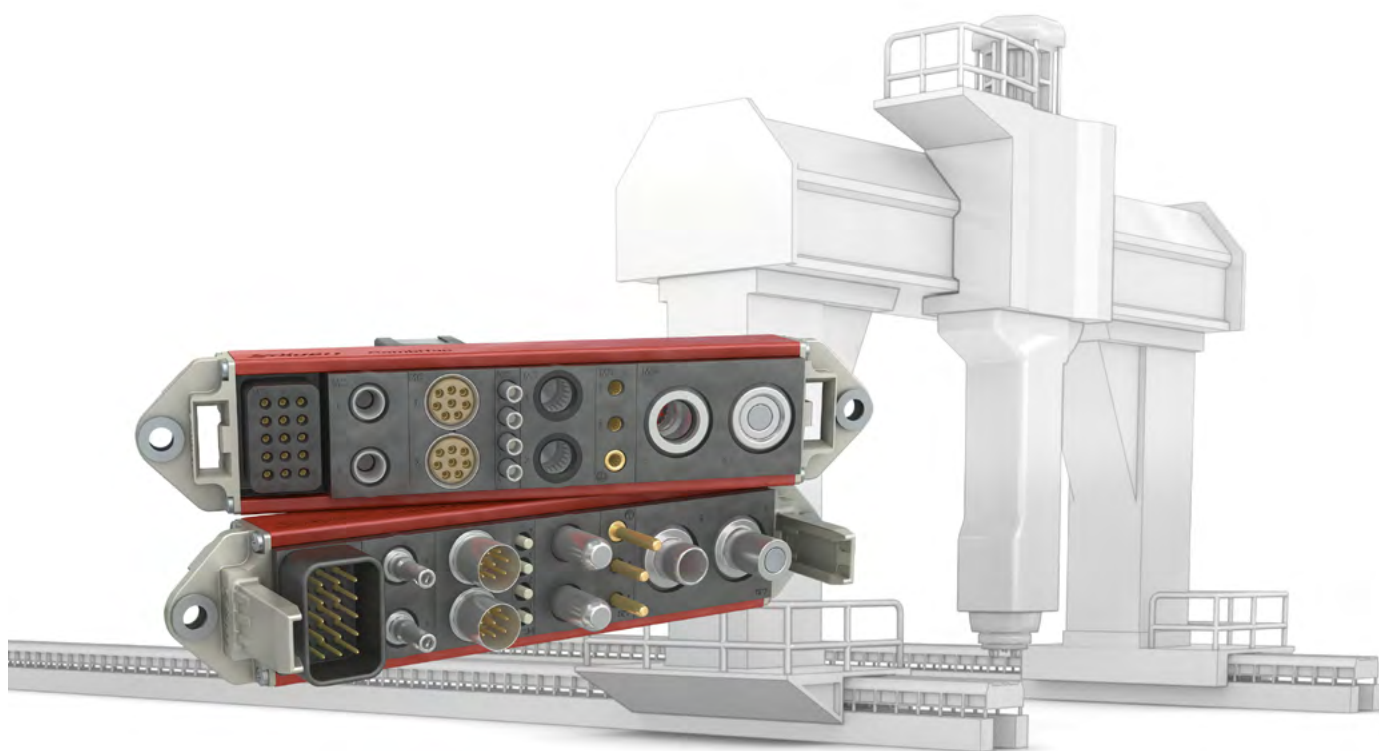

HIGH MISALIGNMENT

High misalignment end pieces CT-BE-...

The CombiTac high misalignment solution makes for radial and angular misalignment absorption during the connection process in docking applications. The pins on the male side serve as guiding pins, the female side has a conic shape. The guiding pins include insulation caps to prevent unintentional contact with live parts on the socket side.

Features:

- Covers radial and angular misalignment up to 4 mm and $\pm 2^\circ$, respectively
- Up to 100,000 mating cycles
- Insulation security on the guiding pins to prevent unintentional contact with live parts on the socket side
- Suitable for all CombiTac uniq panel mount sizes

Benefits:

- All-in-one solution
- Simplify the customer guiding system
- Added user safety
- Long-life solution
- Cost- and space-saving with a ready-to-use solution
- Added value: hybrid connector for power, signals, air and fluid

Applications

CombiTac meets demanding technical specifications (multi-pole, high power, resistance to shock and vibrations) and offers a reliable long-life connector solution.

There are various industries where CombiTac high misalignment end pieces are needed, such as small AGVs, logistics, robotics, e-mobility, automotive, aerospace

and food industry. Typical applications are automated docking/connection for battery swapping of logistic indoor vehicles, material handling and recharging robotic bases. Also, many industries require higher tolerance absorption for automatic connectors in e.g. production lines, testing applications, etc.



Assembly instructions MA213

www.staubli.com/electrical

The end pieces are designed solely for the guiding of the connectors and the associated forces.

In a permanent installation application, the customer must provide a stable guide system, e.g. with mechanical pins.

CT-BE-S/4

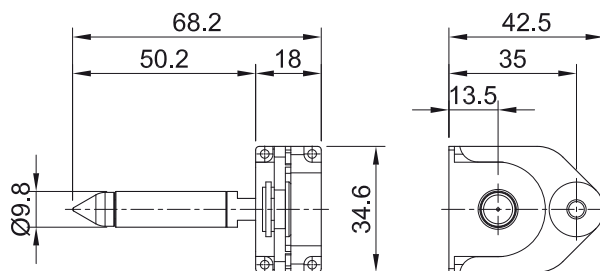

CT-BE-B/4

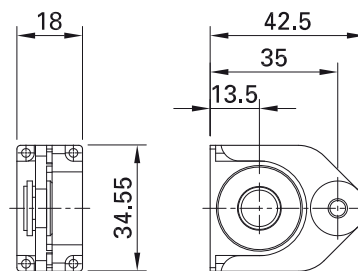
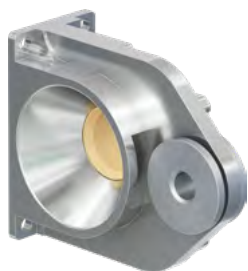

Order No.	Type	Description
33.5727	CT-BE-S/4	Male part for panel mount
33.5726	CT-BE-B/4	Female part for panel mount

Technical data	
Misalignment absorption, radial	4 mm
angular	±2°
Mating cycles	100,000
Material	Nickel-plated brass
Ambient temperature for CT-BE-B/4 ¹⁾	0 °C – 50 °C

¹⁾ Temperature rating of electrical contacts and carriers remains as specified in their relative specification section in catalog.

SINGLE PARTS FOR COMBITAC FRAMES

Single parts for CombiTac frames

Note:

Supporting rails are available in lengths from 18 mm up to 180 mm in steps of 2 mm (18, 20, 22, 24, etc.).

Exception: For housing size 2, a length of 43 mm is required. The length must be stated in mm together with the order No.
Mating cycles of end pieces: > 100,000
The end pieces are designed solely for the

guiding of the connectors and the associated forces.

In a permanent installation application, the customer must provide a stable guide system, e.g. with mechanical pins.



Order No.	Type	Designation	Number per frame		
			Socket	Pin	
33.5606-...	CT-BS	Supporting rail in plastic (PA) (length in mm)	2	2	
33.5601-...	CT-BS-AL	Supporting rail in aluminum, on request (length in mm)	2	2	
33.4056 33.5718	CT-BEG-B CT-BTG-B	Standard end piece for DIN housing, sockets Option without ground connection	2		
33.4057 33.5719	CT-BEG-S CT-BTG-S	Standard end piece for DIN housing, pins Option without ground connection		2	
33.4054 33.4058	CT-BE-B CT-BESZ-B	Standard end piece for panel mounting, sockets Option with ground connection	2		
33.4055 33.4059	CT-BE-S CT-BESZ-S	Standard end piece for panel mounting, pins Option with ground connection		2	
33.5615	LI-BL-SHR	Filister head screw (for securing the end pieces)	8	8	
33.2890	LI-SHR-GF	Torx screw M3x10 (for securing in the Stäubli DIN housing)	4	4	

CALCULATION OF INSTALLATION DIMENSIONS

Calculation of installation dimensions

To determine the dimension L, the width of all contact carriers in the relevant configuration must be taken into account.

Note:

- If necessary, fill up with spacers (see page 74)

- General dimensional tolerances ± 0.1 mm
- L1 (recess dimensions) = L + 22 mm; L2 = L + 33 mm

Type	Number	Width	
CT-E12		x 30 mm	=
CT-E8/6-PE, CT-E6-2		x 16 mm	=
CT-E8-2, CT-E3-.../HV..., CT-E1-26		x 18 mm	=
CT-E3-3, CT-E3/PCB, CT-E3-2+PE		x 10 mm	=
CT-E1,5-4/HV		x 8 mm	=
CT-E1,5-5, CT-E-2TH+PE		x 6 mm	=
CT-E1-15		x 20 mm	=
CT-E1-6		x 4 mm	=
CT-E0,6-20		x 5.1 mm	=
CT-LMFB		x 6 mm	=
CT-E-COAX, CT-NET		x 16 mm	=
CT-10GBIT		x 22 mm	=
CT-RJ45		x 20 mm	=
CT-E-3POF, CT-E-4GOF		x 6 mm	=
CT-E8-4		x 30 mm	=
CT-E-UCT06-1		x 18 mm	=
CT-E-UCT06-2		x 28 mm	=
CT-E-UCT06-4, CT-E-UCT08-2		x 42 mm	=
CT-E-UCT08-1		x 22 mm	=
further moduls			
Contact carriers			
CT-DIP0,5		x 0.5 mm	=
CT-DIP1		x 1 mm	=
CT-DIP2		x 2 mm	=
CT-DIP3		x 3 mm	=
CT-DIP4, CT-DIP4/2		x 4 mm	=
further moduls			
Spacers			
Sum of the widths (min. 18 mm)		L =	

Socket side

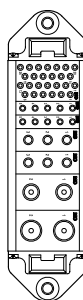

Pin side

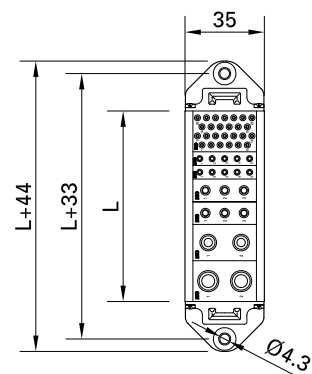

Socket side

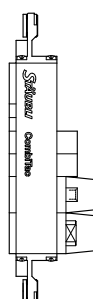

Pin side

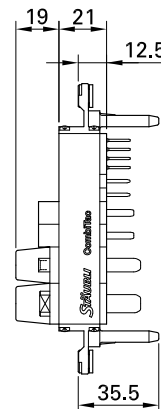

Drilling plan

Panel mounting drilling plan for CombiTac with panel mount end pieces

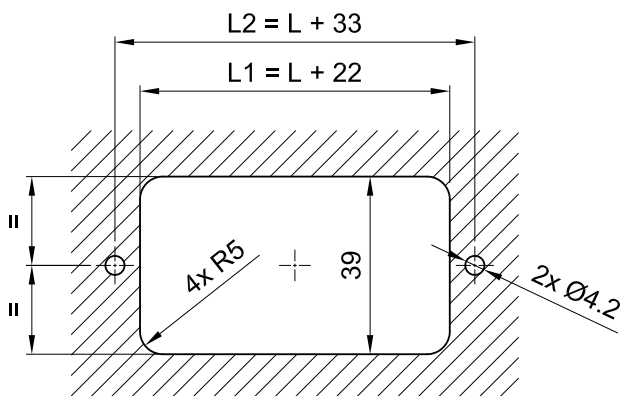

Panel mounting drilling plan for CombiTac with high misalignment end pieces

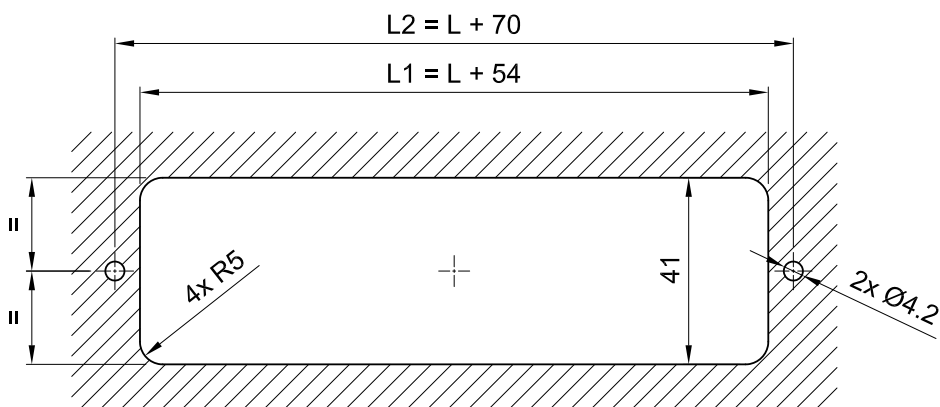

Pin side panel mounting drilling plan for CombiTac with housing end pieces

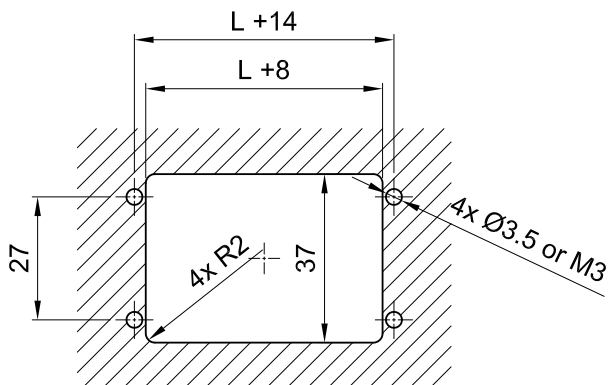

Socket side panel mounting drilling plan for CombiTac with housing end pieces

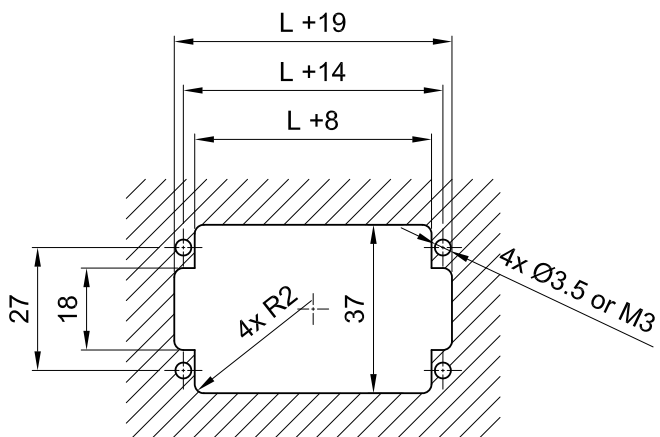

Light Housing drilling plan for CombiTac with housing end pieces

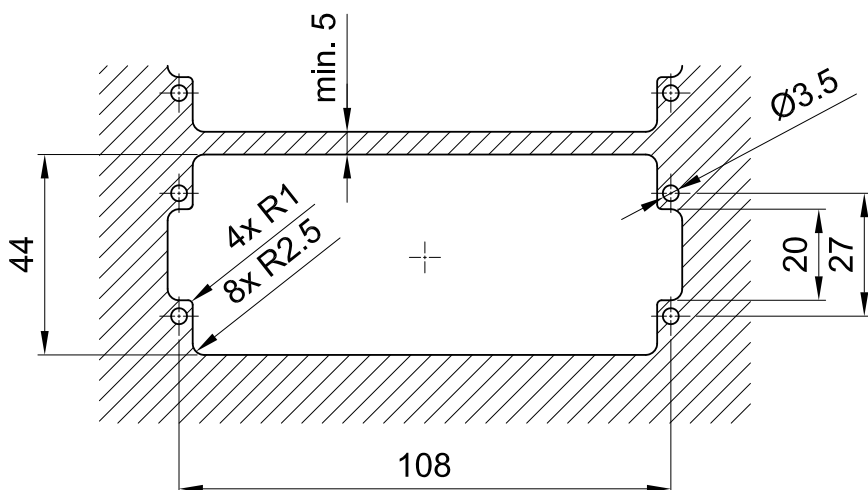

PANEL MOUNTED

Panel mounted

Max. permissible mounting offset

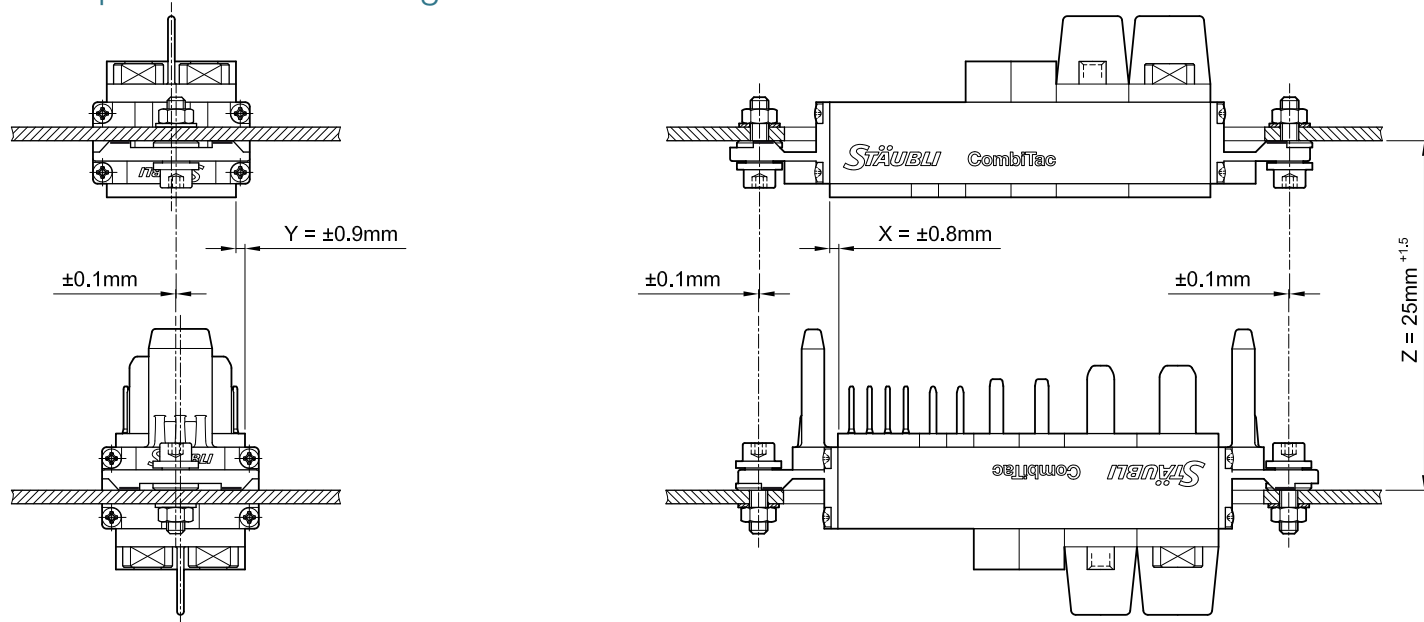

Distance Z in mated condition

Max. permissible mounting angular misalignment during mating

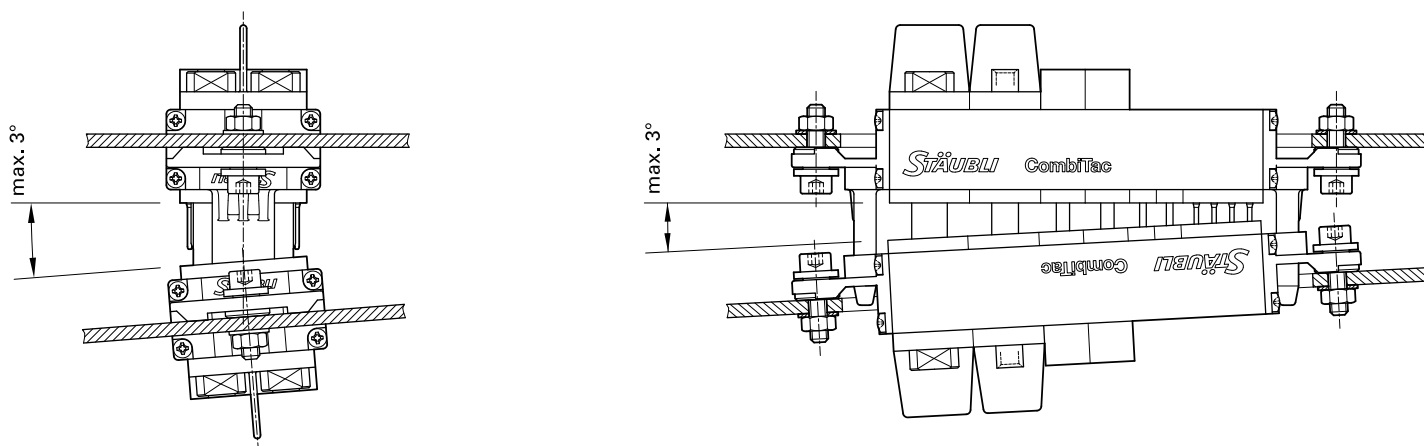

Max. permissible distance between the contact carriers when mated

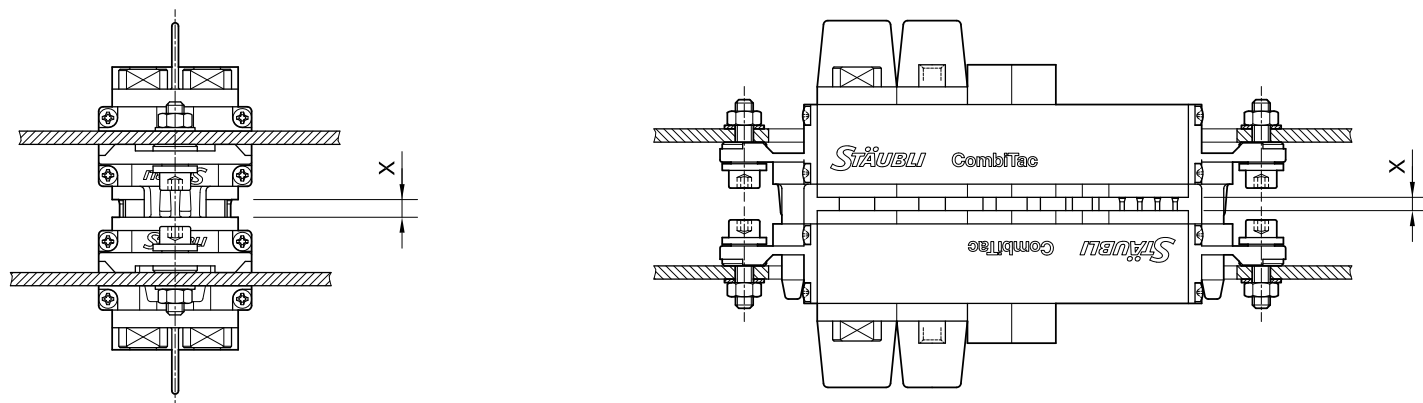

Contacts	Sizes X
	min. > 0 mm; max. mm
CT0.6	1.5
CT1,5	2.75
CT3	2
Further electricals	3
POF crimp version	1.5
POF/SL Lens contact	7.5
Coaxial	1.5
Thermocouple pressure contacts	1.5
CT-NET	2
SCT	2
UCT/RCT	2
CT-E8-2-IP2X	2
CT-LMFB	1
CT-10GBIT	1.5

Plug connections with coupling force and any end position

Coupling forces may not be applied to the plug connectors, frames, and/or guide pins. In cases where these forces exist, the customer must utilize guide pins to protect the connection.

Failure to observe these recommendations can result in damage to the plug connection.

ALUMINUM HOUSINGS INTRODUCTION

Standard DIN housings

Aluminum DIN housings are designed to serve general industrial, healthcare and railway applications. Standard and Space Saving locking mechanisms available.

Available in grey and white color depending on size. Other colors available upon request.

Features depending on type (see table page 85 for details):

- Up to 10,000 mating cycles
- IP65 and IP67 in mated condition
- 6 coding possibilities
- Quick and easy replacement of sealing
- Resistance to shock and vibrations
- IP2X during connecting/disconnecting process when using protective walls
- Ergonomic locking mechanism

- Space saving locking available to save space when placing a high number of housings next to each other

Benefits:

- Minimum service costs
- Added user safety
- Low maintenance costs
- Reliable solution
- Easy handling

Coupler hoods/Surface and pedestal mount housings



Coupler hoods

Can be used with a surface or pedestal mount housing. Available with side or top cable entry, with or without protective wall.

Surface and pedestal mount housings

Both types are used with coupler hoods. The choice of mount housing depends on the cable entry type. Available with or without protective wall or cover.

Coupler hoods and surface housings with space saving locking

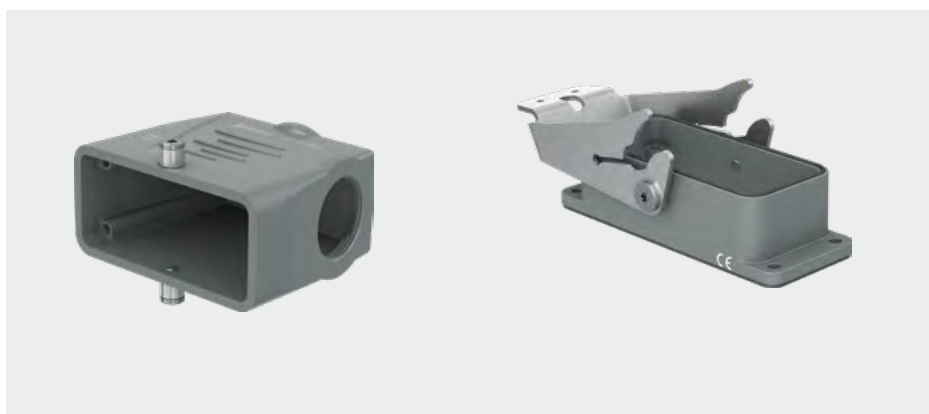

Coupler hoods

Can be used with a surface mount housing. Available with side or top cable entry.

Surface mount housings

Used with coupler hoods.

Accessories

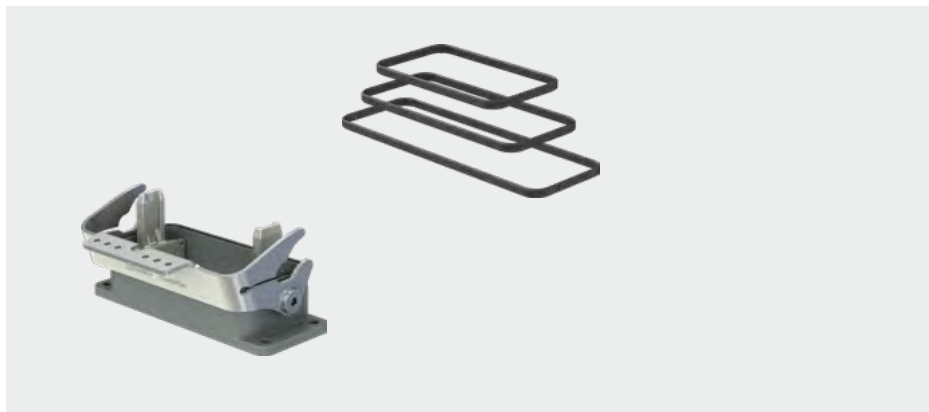

Park stations

- For parking coupler hoods when not in use

Replacement seals (depending on type)

- Available upon request

Technical data DIN housings

Technical data	
Housing material	Aluminum
Seal material	NBR
Locking mechanism material	Stainless steel
Vibrations and shock	IEC 61373:2010 Category 1B

Comparison chart of the different housings

Size	IP65	IP67	Mating cycles	Color	Temperature range	Vibrations and shock	Replaceable seal
						IEC 62847:2016	
1	x		5,000	Grey RAL9006	-40 °C to +90 °C		
2	x	x	10,000	Grey RAL7012 White RAL9003	-40 °C to +125 °C short-term operation -40 °C to +90 °C continuous operation	x	x
3	x	x	10,000	Grey RAL7012 White RAL9003	-40 °C to +125 °C short-term operation -40 °C to +90 °C continuous operation	x	x
4	x	x	10,000	Grey RAL7012 White RAL9003	-40 °C to +125 °C short-term operation -40 °C to +90 °C continuous operation	x	x
5	x		5,000	Grey RAL9006	-40 °C to +90 °C		
6	x		5,000	Grey RAL9006	-40 °C to +90 °C		

¹⁾ Follow maintenance instructions according to MA213

ALUMINUM HOUSING IP65/67

Coupler hood

Coupler hoods can be combined with surface or pedestal mount housing. Available with side or top cable entry.

Note for sizes 2, 3, 4:

For white housing please add the color code number 29, e.g. 33.2362-29. Other colors available upon request.

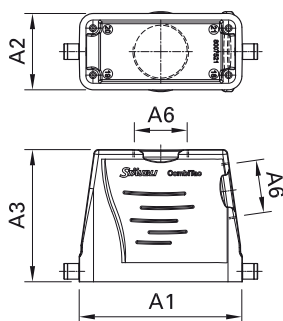

Size	Order No.	Type	IP65	IP67	Cable entry		Sizes (mm)				Standard color
					Side	Top	A1	A2	A3	A6	
1	33.1551	CT-CH1-S	x		x		60	43	72	M32	■
	33.1571	CT-CH1-T	x			x					
2	33.2402	CT-CH2-S	x	x	x		73.8	43.9	70	M32	■ 29
	33.2362	CT-CH2-T	x	x		x					
3	33.2403	CT-CH3-S	x	x	x		93.8	43.9	76	M32	■ 29
	33.2363	CT-CH3-T	x	x		x					
4	33.2404	CT-CH4-S	x	x	x		120.8	43.9	78	M32	■ 29
	33.2364	CT-CH4-T	x	x		x					
5	33.0365	CT-CH5-S	x		x		95	82.5	79	M40	■
	33.0355	CT-CH5-T	x			x					
6	33.0366	CT-CH6-S	x		x		131	89	96	M50	■
	33.0356	CT-CH6-T	x			x					

Coupler housing

Coupler housings can be combined with coupler hoods. Available with top cable entry.

CT-CHG...-T

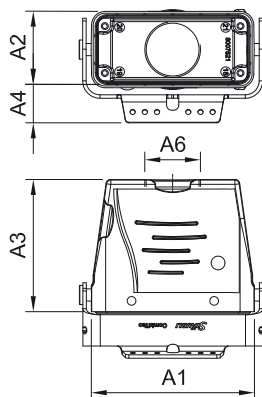

CT-CHG...-T/PW

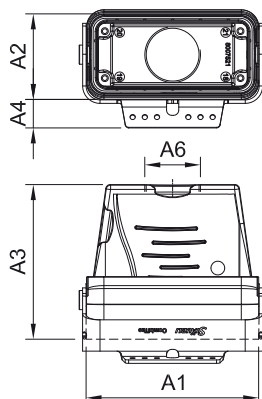

Size	Order No.	Type	IP65	IP67	Cable entry	Protective wall	Sizes (mm)					Standard color
							A1	A2	A3	A4	A6	
1	33.1501	CT-CHG1-T	x		Top		60	43	75	20	M32	
2	33.5082	CT-CHG2-T	x	x	x		73	43	74	35	M32	29
	33.5092	CT-CHG2-T/PW	x	x		x						
3	33.5083	CT-CHG3-T	x	x	x		93.5	43	80	35	M32	29
	33.5093	CT-CHG3-T/PW	x	x		x						
4	33.5084	CT-CHG4-T	x	x	x		120	43	82	35	M32	29
	33.5094	CT-CHG4-T/PW	x	x		x						
5	33.0415	CT-CHG5-T	x		x		95	82.5	82.5	33	M40	



Assembly instructions MA213

www.staubli.com/electrical

Coupler hood with protective wall, IP2X

Coupler hoods with protective walls offer additional damage protection to contacts along with IP2X protection during the connecting/disconnecting process. Protective walls are in black.

Note for sizes 2, 3, 4:



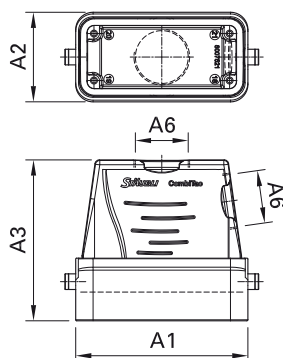

For white housing please add the color code number 29, e.g. 33.2362-**29**. Other colors available upon request.

CT-CH...PW

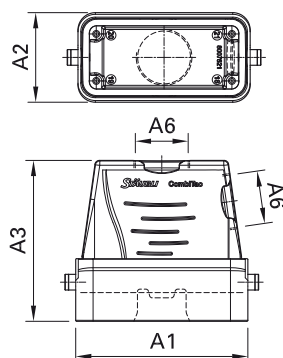





CT-CH...PW-PC



Size	Order No.	Type	IP65	IP67	Cable entry		Sizes (mm)				Standard color
					Side	Top	A1	A2	A3	A6	
2	33.2952	CT-CH2-S/PW	x	x	x		78.5	51.5	86.5	M32	 29
	33.2912	CT-CH2-T/PW	x	x		x					
3	33.2953	CT-CH3-S/PW	x	x	x		99	51.5	92.5	M32	 29
	33.2913	CT-CH3-T/PW	x	x		x					
4	33.2954	CT-CH4-S/PW	x	x	x		125.2	51.5	94.5	M32	 29
	33.2914	CT-CH4-T/PW	x	x		x					
5	33.3255	CT-CH5-S/PW	x		x		101	91	95.5	M40	
	33.3275	CT-CH5-T/PW	x			x					
6	33.3256	CT-CH6-S/PW	x		x		136	98.5	121	M50	
	33.3276	CT-CH6-T/PW	x			x					

for use with housings that include protective covers

2	33.2972	CT-CH2-S/PW-PC	x	x	x		78.5	51.5	86.5	M32	 29
	33.2932	CT-CH2-T/PW-PC	x	x		x					
3	33.2973	CT-CH3-S/PW-PC	x	x	x		99	51.5	92.5	M32	 29
	33.2933	CT-CH3-T/PW-PC	x	x		x					
4	33.2974	CT-CH4-S/PW-PC	x	x	x		125.2	51.5	94.5	M32	 29
	33.2934	CT-CH4-T/PW-PC	x	x		x					
5	33.3295	CT-CH5-S/PW-PC	x		x		101	91	95.5	M40	
	33.3225	CT-CH5-T/PW-PC	x			x					
6	33.3296	CT-CH6-S/PW-PC	x		x		136	98.5	121	M50	
	33.3226	CT-CH6-T/PW-PC	x			x					

Surface mount housing

Surface mount housings are used for bottom cable entry. They are combined with coupler hoods and are available with or without protective wall or cover. Protective walls are in black.

Coupler hoods with protective walls of fer additional damage protection to contacts along with IP2X protection during the connecting/disconnecting process.

Note for sizes 2, 3, 4:

For white housing please add the color code number 29, e.g. 33.2362-29. Other colors available upon request.

CT-SM...

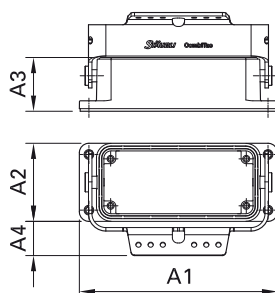



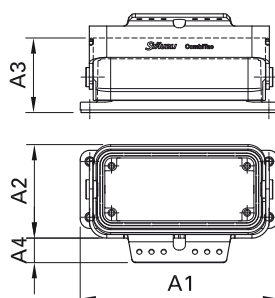

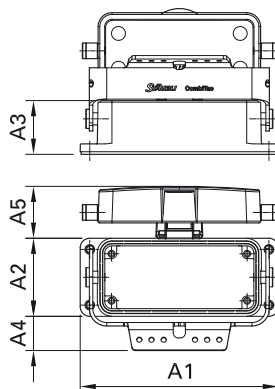

CT-SM...PW



CT-SM...PC



Size	Order No.	Type	IP65	IP67	Protective cover	Protective wall	Sizes (mm)					Standard color	
							A1	A2	A3	A4	A5		
1	33.1561	CT-SM1	x				82	43	29	20	-	26.5	
	33.1591	CT-SM1-PC	x		x								
2	33.2302	CT-SM2	x	x			94	44.9	28.5	32.9	-	-	
	33.2852	CT-SM2/PW	x	x		x							
	33.2332	CT-SM2-PC	x	x	x								
3	33.2303	CT-SM3	x	x			114	44.9	28.5	32.9	-	-	
	33.2853	CT-SM3/PW	x	x		x							
	33.2333	CT-SM3-PC	x	x	x								
4	33.2304	CT-SM4	x	x			141	44.9	28.5	32.9	-	-	
	33.2854	CT-SM4/PW	x	x		x							
	33.2334	CT-SM4-PC	x	x	x								
5	33.0375	CT-SM5	x				124	90	36	27	-	-	
	33.3235	CT-SM5/PW	x			x							
	33.0385	CT-SM5-PC	x		x								
6	33.0376	CT-SM6	x				165	90	38.5	50	-	25	
	33.0386	CT-SM6-PC	x		x								

Pedestal mount housing

Pedestal mount housings are used for left and/or right side cable entry. They are combined with coupler hoods and are available with or without protective wall or cover. Protective walls are black.

Pedestal mount with protective walls offer additional damage protection to contacts along with IP2X protection during the connecting/disconnecting process.

Note for sizes 2, 3, 4:

For white housing please add the color code number 29, e.g. 33.2362-29. Other colors available upon request.

CT-PM...

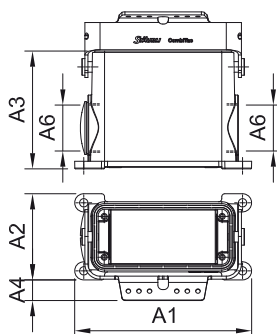



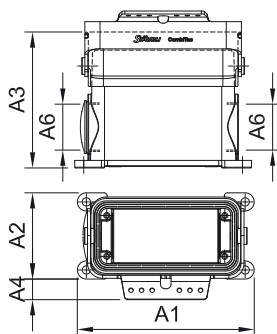

CT-PM...PW

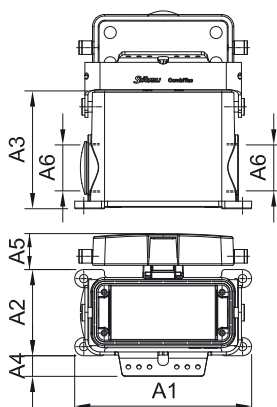

CT-PM...PC



Size	Order No.	Type	IP65	IP67	Protective cover	Protective wall	Sizes (mm)						Standard color	
							A1	A2	A3	A4	A5	A6		
1	33.1541	CT-PM1	x				82	54.5	74	13.5	-	20	M32	
	33.1581	CT-PM1-PC	x		x									
2	33.2462	CT-PM2	x	x			94	57	74	26.9	-	M32		29
	33.2872	CT-PM2/PW	x	x		x			86.9		-			
	33.2702	CT-PM2-PC	x	x	x				74		23.8			
3	33.2463	CT-PM3	x	x			117	57	77	26.9	-	M32		29
	33.2873	CT-PM3/PW	x	x		x			90		-			
	33.2703	CT-PM3-PC	x	x	x				77		23.8			
4	33.2464	CT-PM4	x	x			144	57	79	26.9	-	M32		29
	33.2874	CT-PM4/PW	x	x		x			92		-			
	33.2704	CT-PM4-PC	x	x	x				79		23.8			
5	33.1025	CT-PM5	x				126	92.5	78.5	33	-	M32		
	33.2085	CT-PM5/PW	x			x			92.8		-			
	33.1035	CT-PM5-PC	x		x				78.5		22			
6	33.0396	CT-PM6	x				140	120	98.5	37	-	M40		
	33.0406	CT-PM6-PC	x		x						10			

Park stations

Used for parking coupler hoods when they are not connected to mount housings.

Note for sizes 2, 3, 4:

For white housing please add the color code number 29, e.g. 33.2362-29. Other colors available upon request.

CT-PS...SM/P

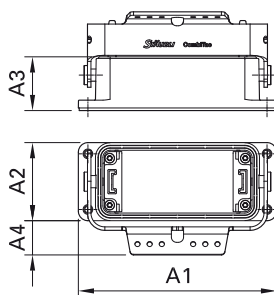

CT-PS...SM/S

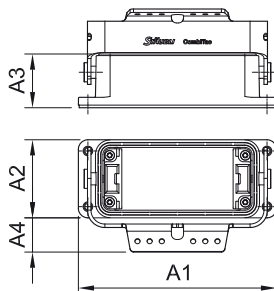

CT-PS...PC-SM/S

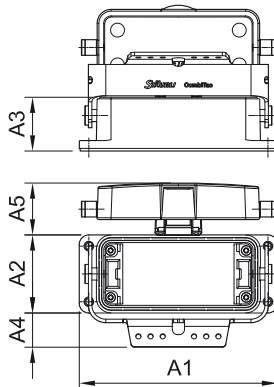

Size	Order No.	Type	IP65	IP67	Pin end pieces	Socket end pieces	Protective cover	Sizes (mm)					Standard color
								A1	A2	A3	A4	A5	
1	34.0340	CT-PS1-SM/P	x		x			82	43	29	21		
	34.0341	CT-PS1-SM/S	x			x							
2	33.1802	CT-PS2-SM/P	x	x	x			94	44.9	28.5	32.9	29.8	■ 29
	33.1812	CT-PS2-SM/S	x	x		x							
	33.1832	CT-PS2/PC-SM/S	x	x		x	x						
3	33.1803	CT-PS3-SM/P	x	x	x			114	44.9	28.5	32.9	29.8	■ 29
	33.1813	CT-PS3-SM/S	x	x		x							
	33.1833	CT-PS3/PC-SM/S	x	x		x	x						
4	33.1804	CT-PS4-SM/P	x	x	x			141	44.9	28.5	32.9	29.8	■ 29
	33.1814	CT-PS4-SM/S	x	x		x							
	33.1834	CT-PS4/PC-SM/S	x	x		x	x						
5	34.0354	CT-PS5-SM/P	x		x			124	84	36	33	22	■
	34.0355	CT-PS5-SM/S	x			x							
	34.0358	CT-PS5/PC-SM/S	x			x	x						
6	34.0356	CT-PS6-SM/P	x		x			165	90	38.5	50	25	■
	34.0357	CT-PS6-SM/S	x			x							
	34.0359	CT-PS6/PC-SM/S	x			x	x						

Replacement seals

Replacement housing seals made of NBR can be reordered.

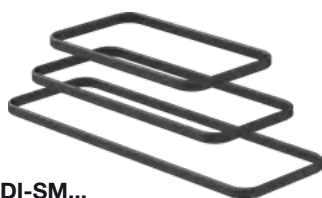

CT-DDI-SM...



CT-PDI-SM...

Size	Order No.	Type	Description
2	33.2782	CT-DDI-SM2	Upper seal
3	33.2783	CT-DDI-SM3	
4	33.2784	CT-DDI-SM4	
2	33.2792	CT-PDI-SM2	Lower seal
3	33.2793	CT-PDI-SM3	
4	33.2794	CT-PDI-SM4	

Protective cap

For mounting on all surface and pedestal mountings or coupler hood with pin end pieces. Protective cap suitable for all pin lengths.

Protective cover material: PA.

Note:

It is not possible to use the protective cap together with a protective wall.



Size	Order No.	Type	for metal housing
1	33.1301	CT-PC-SM1-L/FSCH	x
2	33.1302	CT-PC-SM2-L/FSCH	x
3	33.1303	CT-PC-SM3-L/FSCH	x
4	33.1304	CT-PC-SM4-L/FSCH	x
5	33.1305	CT-PC-SM5-L/FSCH	x
6	33.1306	CT-PC-SM6-L/FSCH	x



HOUSINGS WITH SPACE SAVING LOCKING

Coupler hood

Coupler hoods can be combined with surface mount housing. Available with side or top cable entry.

Note for sizes 2, 3, 4:

For white housing, please add the color code number 29, e.g. 33.2362-**29**. Other colors available upon request.

CT-CH...-S/SSL

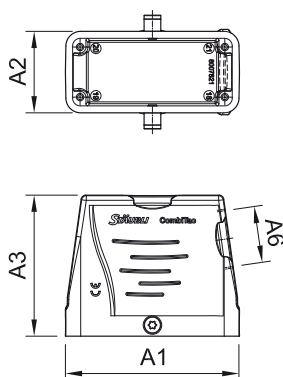

CT-CH...-T/SSL

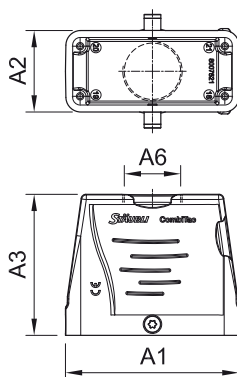

Size	Order No.	Type	IP67	Cable entry		Sizes (mm)				Standard color
				Side	Top	A1	A2	A3	A6	
2	35.1242	CT-CH2-S/SSL	x	x		74	44	70	M32	29
	35.1232	CT-CH2-T/SSL	x		x					
3	35.1243	CT-CH3-S/SSL	x	x		94	44	76	M32	29
	35.1233	CT-CH3-T/SSL	x		x					
4	35.1244	CT-CH4-S/SSL	x	x		120	44	78	M32	29
	35.1234	CT-CH4-T/SSL	x		x					

Surface mount housing

Surface mount housings are used for bottom cable entry. They are combined with coupler hoods.

Note for sizes 2, 3, 4:

For white housing, please add the color code number 29, e.g. 33.2362-**29**. Other colors available upon request.

CT-SM...

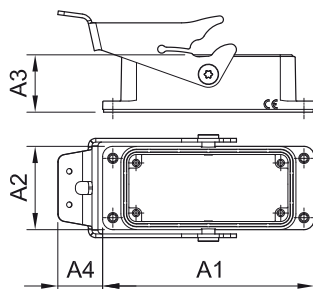

Size	Order No.	Type	IP67	Sizes (mm)					Standard color
				A1	A2	A3	A4		
							Locked	Unlocked	
2	35.1252	CT-SM2/SSL	x	94	45	29	3.3	26	■ 29
3	35.1253	CT-SM3/SSL	x	114	45	29	7.8	31	■ 29
4	35.1254	CT-SM4/SSL	x	141	45	29	3.9	30	■ 29

Park stations

Used for parking coupler hoods when they are not connected to mount housings.

Includes CombiTac uniq frames.

Note for sizes 2, 3, 4:

For white housing, please add the color code number 29, e.g. 33.2362-29. Other colors available upon request.

CT-PS...-SM/SSL/P

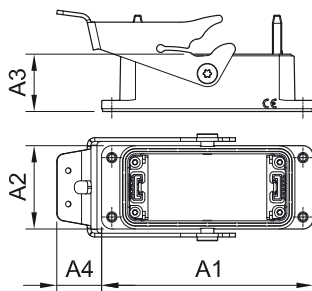

CT-PS...-SM/SSL/S

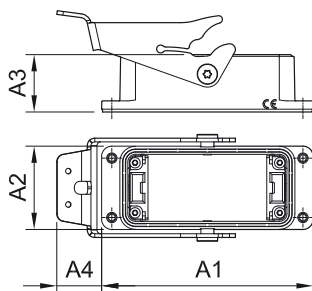

Size	Order No.	Type	IP67	Pin end pieces	Socket end pieces	Sizes (mm)					Standard color
						A1	A2	A3	A4		
									Locked	Unlocked	
2	33.1742	CT-PS2-SM/SSL/P	x	x		94	45	29	3.3	26	29
	33.1782	CT-PS2-SM/SSL/S	x		x						
3	33.1743	CT-PS3-SM/SSL/P	x	x		114	45	29	7.8	31	29
	33.1783	CT-PS3-SM/SSL/S	x		x						
4	33.1744	CT-PS4-SM/SSL/P	x	x		141	45	29	3.9	30	29
	33.1784	CT-PS4-SM/SSL/S	x		x						

Replacement seals

Replacement housing seals made of NBR can be reordered.

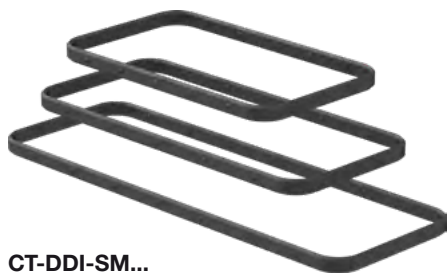

CT-DDI-SM...



CT-PDI-SM...

Size	Order No.	Type	Description
2	33.2782	CT-DDI-SM2	Upper seal
3	33.2783	CT-DDI-SM3	
4	33.2784	CT-DDI-SM4	
2	33.2792	CT-PDI-SM2	Lower seal
3	33.2793	CT-PDI-SM3	
4	33.2794	CT-PDI-SM4	

ALUMINUM HOUSING IP68/69K

Coupler hood

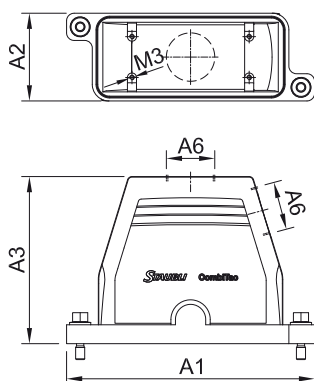

The all-round contact of the two housing halves of the IP68/69K enclosures provides a 360° shielding against electromagnetic influence according to VG 95373-41.

Size	Order No.	Type	Cable entry		Sizes (mm)			
			Side	Top	A1	A2	A3	A6
1	33.6871	CT-TG1-S IP68 HE	×		132	58	100.5	M32
	33.6881	CT-TG1-G IP68 HE		×				
2	33.6872	CT-TG2-S IP68 HE	×		144	58	100.5	M32
	33.6882	CT-TG2-G IP68 HE		×				
3	33.6873	CT-TG3-S IP68 HE	×		164	58	110.5	M40
	33.6883	CT-TG3-G IP68 HE		×				
4	33.6874	CT-TG4-S IP68 HE	×		191	58	110.5	M40
	33.6884	CT-TG4-G IP68 HE		×				

Surface mount housing

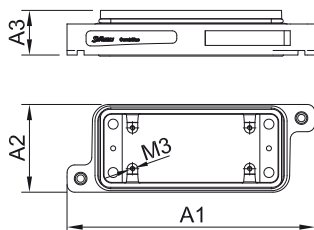

Size	Order No.	Type	Sizes (mm)		
			A1	A2	A3
1	33.6851	CT-AG1 IP68 HE	132	58	29.5
2	33.6852	CT-AG2 IP68 HE	144	58	29.5
3	33.6853	CT-AG3 IP68 HE	164	58	29.5
4	33.6854	CT-AG4 IP68 HE	191	58	29.5

Pedestal mount housing

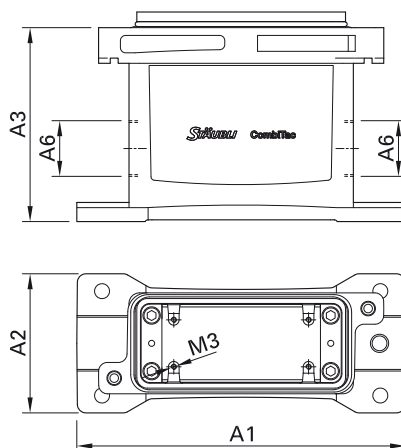

Size	Order No.	Type	Sizes (mm)			
			A1	A2	A3	A6
1	33.6861	CT-SG1 IP68 HE	156	80	100.5	2×M25
2	33.6862	CT-SG2 IP68 HE	169	80	100.5	2×M32
3	33.6863	CT-SG3 IP68 HE	189	80	111.5	2×M32
4	33.6864	CT-SG4 IP68 HE	216	80	111.5	2×M40

Protective cap



Size	Order No.	Type
1	33.6891	CT-PC1 IP68 HE
2	33.6892	CT-PC2 IP68 HE
3	33.6893	CT-PC3 IP68 HE
4	33.6894	CT-PC4 IP68 HE

Central locking IP65 (on request)

CT-CH.../ZV

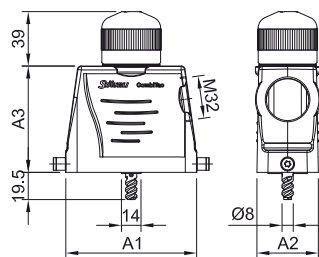

CT-SM.../ZV

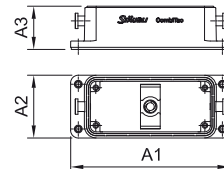

Size	Order No.	Type	Designation	Sizes (mm)			Standard color
				A1	A2	A3	
	33.1418	CT-ZV/B	Locking head complete	–	–	–	
2	33.4018-2	CT-E-ZV/B/TG2	Carrier with threaded spindle	–	–	–	
3	33.4018-3	CT-E-ZV/B/TG3		–	–	–	
4	33.4018-4	CT-E-ZV/B/TG4		–	–	–	
	33.4021	CT-E-ZV/S	Thread carrier	–	–	–	
2	33.1862	CT-CH2/ZV-R	Coupler hood for central locking	73	43	70	■ 29
3	33.1863	CT-CH3/ZV-R		93.5	43	76	
4	33.1864	CT-CH4/ZV-R		120	43	78	
2	33.1852	CT-SM2/ZV	Surface mount housing for central locking	93	43.5	28.5	■ 29
3	33.1853	CT-SM3/ZV		113	43.5	28.5	
4	33.1854	CT-SM4/ZV		140	43.5	28.5	

PLASTIC HOUSING IP65

Plastic DIN housing

The plastic housing is primarily intended for industrial use or for applications where a high resistance to chemical environmental influences is required.

In addition, the plastic housing is mechanically robust.

As the housing is made of antistatic thermoplastic material, there is no need for additional grounding.



Technical data

Housing material	Thermoplastic
Housing seal	Elastomer
Locking element	Thermoplastic
Degree of protection mated/locked	IP65

Plastic housing – Resistance to aggressive media		
	Resistant	Limited resistance
1-Pentanol		x
Alum	x	
Amide, aqueous	x	
Ammonia gas		x
Ammonia, 10 % aqueous solution	x	
Ammonium acetate	x	
Ammonium carbonate	x	
Ammonium chloride	x	
Ammonium nitrate	x	
Ammonium phosphate	x	
Ammonium sulfate	x	
Aniline		x
Asphalt		x
Beer	x	
Borated water	x	
Borax		x
Boric acid, 10 % aqueous solution	x	
Boric acid	x	
Butane gas		x
Butane, liquid		x
Calcium chloride, 10 % aqueous solution	x	
Calcium chloride	x	
Calcium nitrate	x	
Calcium sulfate	x	
Chlorinated lime, diluted	x	
Copper sulfate, 10 % aqueous solution	x	
Cresol acids		x
Cresol solution		x
Cutting oil		x
Cyclohexane		x
Diesel		x
Diisononyl phthalate	x	
Di-Octyl-Phthalate	x	
Diluted glucose	x	
Diluted glycerol	x	
Diluted glycol	x	
Diluted phenol		x
Ethanol, non-denaturized	x	
Ethylene glycol or propylene glycol	x	
Fatty acids	x	
Fruit juices	x	
Gasoline		x

Plastic housing – Resistance to aggressive media		
	Resistant	Limited resistance
Glycerol	x	
Grinding oil		x
Gypsum (see calcium sulfate)	x	
Heptane		x
Hexane		x
Hydrogen sulfide		x
Ink	x	
Isopropyl alcohol		x
Lactic acid	x	
Linseed oil	x	
Lubricating oil	x	
Mercury	x	
Methanol, diluted by 50 %		x
Mineral oil	x	
Mineral spirits (Avio)		x
Mineral-based oil	x	
Mothballs		x
Motor oil		x
n-Butanol	x	
Naphthalene		x
Octane		x
Oil IRM 901, 20 °C	x	
Oil IRM 902, 20 °C		x
Oil IRM 903, 20 °C		x
Oil		x
Oleic acid	x	
Oxalic acid	x	
Paraffin oil	x	
Petroleum	x	
Phthalate	x	
Potassium carbonate	x	
Potassium chlorate	x	
Potassium chloride	x	
Potassium chromate		x
Potassium cyanide, aqueous solution	x	
Potassium iodide		x
Potassium nitrate		x
Potassium persulfate		x
Potassium sulfate		x
Seawater	x	
Silicone oil	x	
Soap solution		x

Plastic housing – Resistance to aggressive media		
	Resistant	Limited resistance
Sodium bicarbonate	x	
Sodium carbonate	x	
Sodium chlorate	x	
Sodium chloride (table salt)	x	
Sodium hydrogen sulfate, aqueous solution	x	
Sodium hydroxide 12.5 % (alkaline solution)		x
Sodium nitrate	x	
Sodium nitrite		x
Sodium perborate	x	
Sodium phosphate	x	
Sodium silicate	x	
Sodium sulfate	x	
Sodium sulfide	x	
Sodium thiosulfate (fixing salt/developing film)	x	
Solution for developing photographs	x	
Stearic acid	x	
Succinic acid	x	
Sulfur dioxide		x
Sulfur	x	
Table salt, aqueous solution	x	
Tallow	x	
Tartaric acid	x	
Tar		x
Transformer oil	x	
Tricresyl phosphate	x	
Turpentine substitute		x
Urea, diluted	x	
Urine	x	
Vegetable oil	x	
Water	x	
White spirits (isopropanol and ethanol)		x

Coupler hood

CT-TG1-S TP

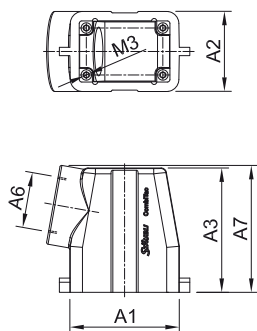

CT-TG...-G TP

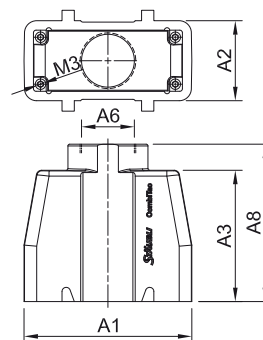

Size	Order No.	Type	Cable entry		Sizes (mm)					
			Side	Top	A1	A2	A3	A6	A7	A8
1 ¹⁾	33.6011	CT-TG1-S TP	x		63	46	71.5	M32	73	86.5
	33.6021	CT-TG1-G TP		x						
2	33.6012	CT-TG2-S TP	x		76	46	71.5	M32	73	86.5
	33.6022	CT-TG2-G TP		x						
3	33.6013	CT-TG3-S TP	x		96.5	46	75.5	M32	79	90.5
	33.6023	CT-TG3-G TP		x						
4	33.6014	CT-TG4-S TP	x		123	46	75.5	M32	79	90.5
	33.6024	CT-TG4-G TP		x						

Surface mount housing

CT-AG1 TP

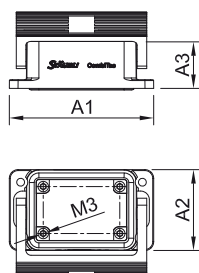

CT-AG...TP

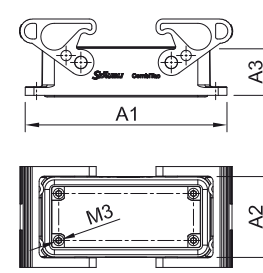

Size	Order No.	Type	Sizes (mm)		
			A1	A2	A3
1 ¹⁾	33.6041	CT-AG1 TP	83	46	27
2	33.6042	CT-AG2 TP	96	46	27
3	33.6043	CT-AG3 TP	116	46	27
4	33.6044	CT-AG4 TP	143	46	27

¹⁾ Size 1: housings only have a single locking device.

Pedestal mount housing

CT-SG1 TP

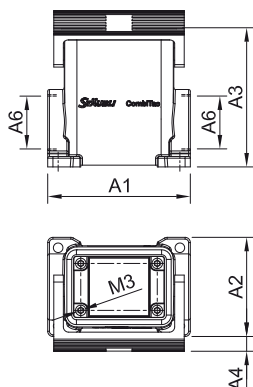

CT-SG...TP

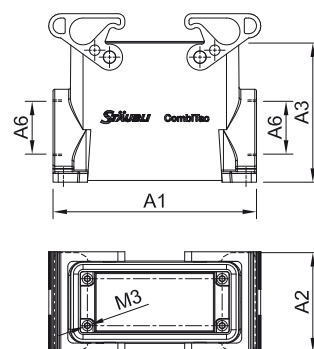

Size	Order No.	Type	Sizes (mm)			
			A1	A2	A3	A6
1 ¹⁾	33.6601	CT-SG1 TP	82	57	73	M32
2	33.6602	CT-SG2 TP	94	57	80	M32
3	33.6603	CT-SG3 TP	117	57	80	M32
4	33.6604	CT-SG4 TP	144	57	80	M32

Protective cap

CT-SD-AG1 TP



CT-SD-AG... TP



Size	Order No.	Type
1 ¹⁾	33.6031	CT-SD-AG1 TP
2	33.6032	CT-SD-AG2 TP
3	33.6033	CT-SD-AG3 TP
4	33.6034	CT-SD-AG4 TP

¹⁾ Size 1: housings only have a single locking device.

Park station plastic housing

Park station with plug end pieces to fit coupler hood socket side (picture top).

Park station with socket end pieces to fit coupler hood pin side (picture bottom).

CT-AG...TP PS/S

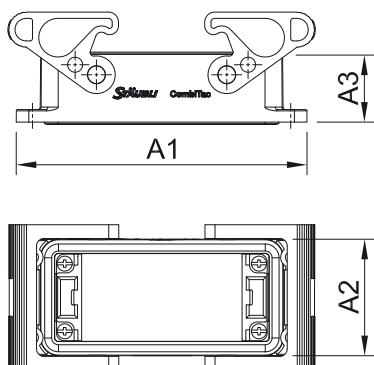

CT-AG...TP PS/B

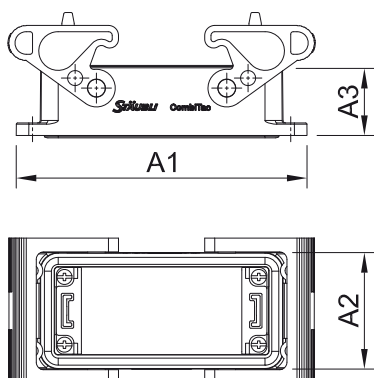

Size	Order No.	Type	End pieces		Sizes (mm)		
			Pin	Socket	A1	A2	A3
1	33.0340	CT-AG1TP PS/S	x		83	46	27
	33.0341	CT-AG1TP PS/B		x			
2	33.0342	CT-AG2TP PS/S	x		96	46	27
	33.0343	CT-AG2TP PS/B		x			
3	33.0344	CT-AG3TP PS/S	x		116	46	27
	33.0345	CT-AG3TP PS/B		x			
4	33.0346	CT-AG4TP PS/S	x		143	46	27
	33.0347	CT-AG4TP PS/B		x			



Protective grounding of conductive housings

Appropriate ground protection is available for conductive DIN housings to protect the users against electrical shock, according to IEC 61140:20161).

CombiTac conductive housings can be grounded internally through its end pieces or the CombiTac PE module.

Protective grounding through end pieces

For live conductors 0.14 mm² – 6 mm²
(AWG 26 – 10)

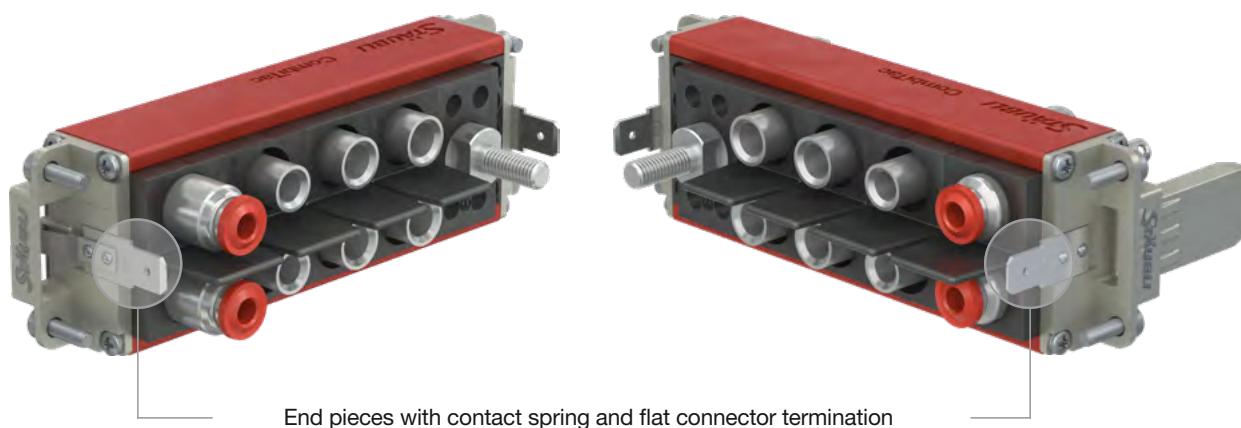

Protective grounding through PE module

For live conductors 10 mm² – 95 mm²
(AWG 8 – 3/0)

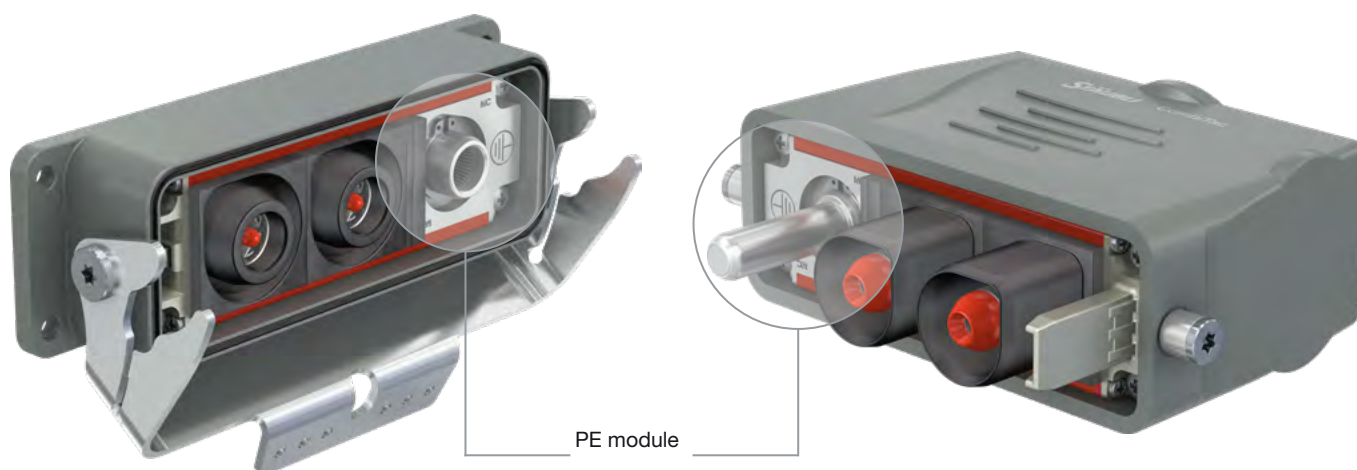

¹⁾ For voltages > DC 60 V or > AC 30 V, metal (conductive) housings must be connected to protective earth (PE).

Protective grounding internally through end pieces

Conductive DIN housings that include live conductors with cross section areas 0.14 mm² – 6 mm² (AWG 26 – 10) can be protective grounded through the CombiTac end pieces.

Type of termination:

- Flat connector termination 6.3 mm x 0.8 mm

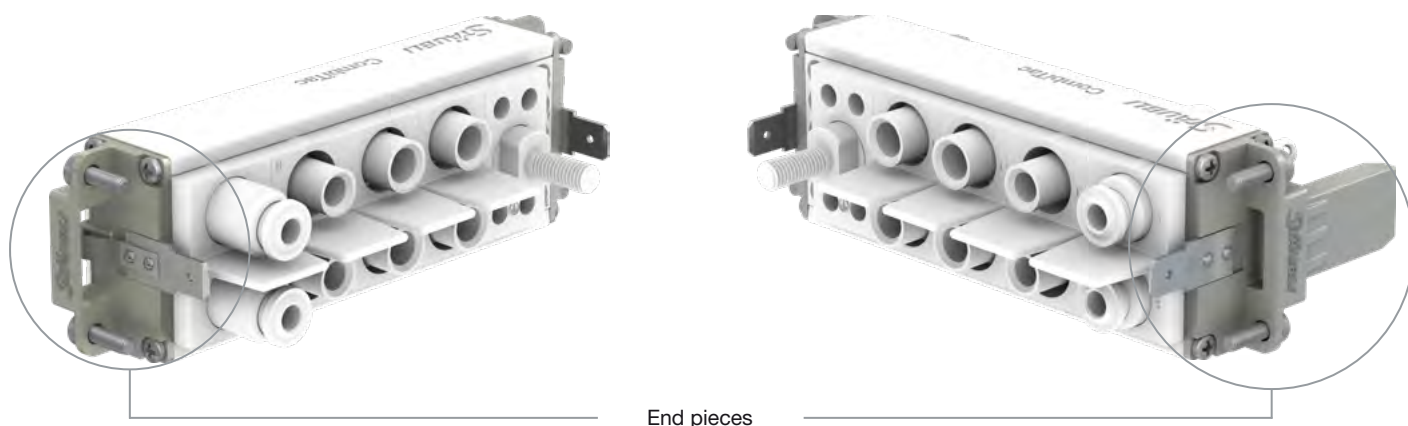

Order No.	Type	Designation	Number per frame		
			Socket	Pin	
33.4056	CT-BEG-B	Standard end piece for DIN housing, socket	2		
33.4057	CT-BEG-S	Standard end piece for DIN housing, pin		2	

PE module

The CombiTac PE module is used for internal protective grounding of CombiTac conductive housings size 2 – 6.

The PE module carrier replaces one of the end pieces and is directly connected to the housing.

- The size of the PE module contacts is determined by the cross section area of the largest live conductor used in the CombiTac configuration (see selection table page 116).

- Aluminum rails are required to ensure correct protective grounding of conductive housings.
- Fitted with MULTILAM

CT-GND10 AG

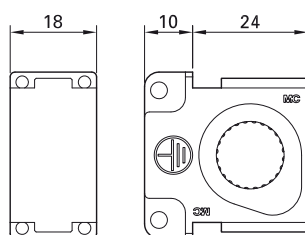

Order No.	Type	Description
33.4165	CT-GND10 AG	PE module carrier

Technical data	
Number of poles	1
For contact diameter	10 mm
Contact carrier material	Brass
Limiting temperature (IEC 61984:2008), upper	+90 °C
lower	-40 °C



Required tools

For the required tools please refer to MA213-09.



Assembly instructions MA213-09

www.staubli.com/electrical

PE module contacts

For protective grounding purposes only, used in combination with CT-GND10 carrier. Fitted with MULTILAM.

Type of termination:

- Crimp termination (C)
- Contacts secured in carrier by means of retaining ring

CT-BP10/.../PE-GND AG

CT-SP10/.../PE-GND AG



Socket side

Pin side

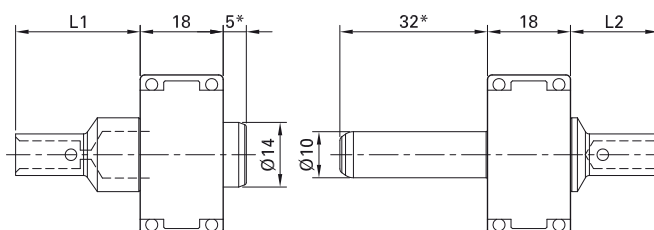

Order No.	Type	Socket	Pin	Surface	Conductor cross section		Short circuit current		Type of termination
					mm ²	AWG	1s kA	3s kA	
33.0215 33.0715	CT-BP10/10/PE-GND AG CT-SP10/10/PE-GND AG	x	x		10	8	1.5	0.8	C
33.0214 33.0714	CT-BP10/16/PE-GND AG CT-SP10/16/PE-GND AG	x	x		16	6	2.3	1.3	C
33.0216 33.0716	CT-BP10/25/PE-GND AG CT-SP10/25/PE-GND AG	x	x		25		2.3	1.5	C
33.0217 33.0717	CT-BP10/AWG4/PE-GND AG CT-SP10/AWG4/PE-GND AG	x	x			4	2.3	1.5	C
33.0213 33.0713	CT-BP10/35/PE-GND AG CT-SP10/35/PE-GND AG	x	x		35	2	2.3	1.5	C
33.0212 33.0712	CT-BP10/50/PE-GND AG CT-SP10/50/PE-GND AG	x	x		50	1/0	2.3	1.5	C

Technical data

Nominal-Ø socket/pin	10 mm
Average sliding force	11 N
Connector resistance	<60 µΩ
Mating cycles	10,000
Vibrations	4.2 g/5 Hz – 250 Hz (IEC 61373:2010) 10 g/10 Hz – 500 Hz (IEC 60068-2-6)
Resistance to shocks	30 g/18 ms (IEC 61373:2010)

* Sizes are the same for all types of terminations.



Assembly instructions MA213-09

www.staubli.com/electrical

PE module contacts selection table

According to IEC 61984:2008, the size of a PE conductor cross section depends on the size of the live conductor cross section. In a CombiTac configuration, the size of the largest live conductor determines the size of the PE conductor.

For example, if Ø 12 mm CombiTac contacts are used with 95 mm² live conductor cross sections, then a 50 mm² PE conductor is required (i.e. requires CT-SP10/50/... and CT-BP10/50/...).

The table below indicates the suitable PE contacts and housing size.

		mm ² AWG	mm ² AWG	mm ² AWG	mm ² AWG	mm ² AWG	mm ² AWG	mm ² AWG	mm ² AWG
Largest live conductor cross section		10 8	16 6	25 4	35 2	50 -	- 1/0	70 2/0	95 3/0
Required PE conductor cross section according to IEC 61984:2008		10 8	16 6	16 6	16 6	25 -	- 4	35 2	50 1/0
Suitable PE module pins/socket	CT-SP10/10/PE-GND AG	x							
	CT-BP10/10/PE-GND AG	x							
	CT-SP10/16/PE-GND AG		x	x	x				
	CT-BP10/16/PE-GND AG		x	x	x				
	CT-SP10/25/PE-GND AG					x			
	CT-BP10/25/PE-GND AG					x			
	CT-SP10/AWG4/PE-GND AG						x		
	CT-BP10/AWG4/PE-GND AG						x		
	CT-SP10/35/PE-GND AG							x	
	CT-BP10/35/PE-GND AG							x	
	CT-SP10/50/PE-GND AG								x
	CT-BP10/50/PE-GND AG								x
Suitable housing size	2	x	x	x	x				
	3	x	x	x	x	x	x	x	x
	4	x	x	x	x	x	x	x	x
	5	x	x	x	x	x	x	x	x
	6	x	x	x	x	x	x	x	x

Restrictions concerning the DIN surface mount housing with protective cover

If the max. pin length (see table) is exceeded, or if a DIN surface mount housing is fitted in

combination with end pieces for plugs, the protective cover cannot be closed.

Note:

For assembly end pieces in housings, please refer to MA213.

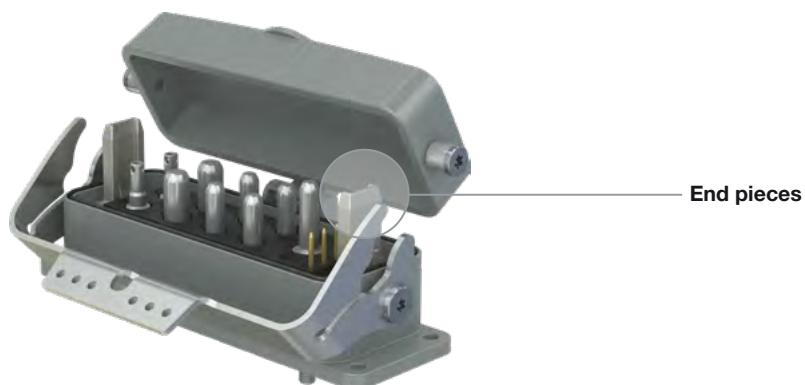

Housing size	Pin length
	max. mm
1	14
2	17
3	17
4	17
5	12
6	16.5

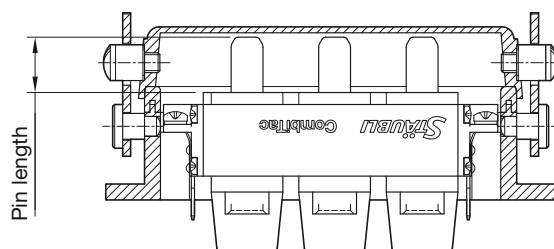

Grounding over end pieces

End pieces with contact spring and flat plug connection (6.3×0.8 mm) permits connection between the two housings and ground.

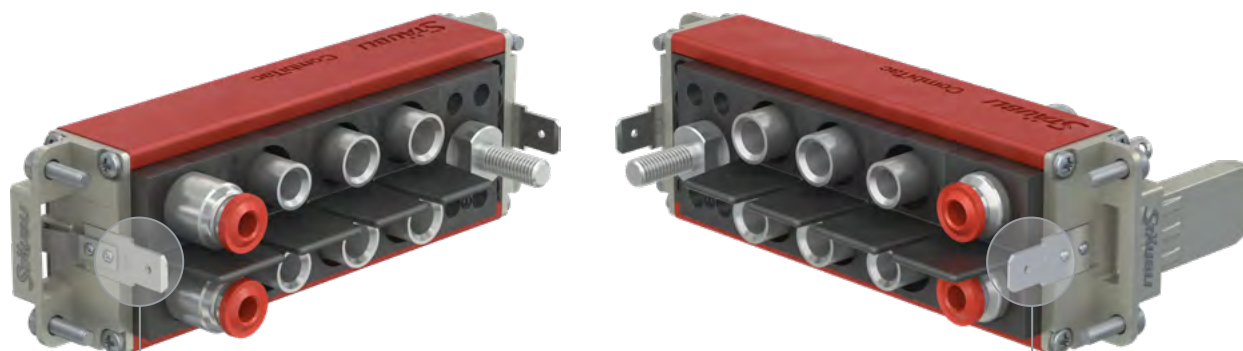

End pieces with contact spring and flat plug connection

Coding

CombiTac in housings can be coded by fitting coding pins in place of the fixing screws. A total of 6 coding variants are possible.

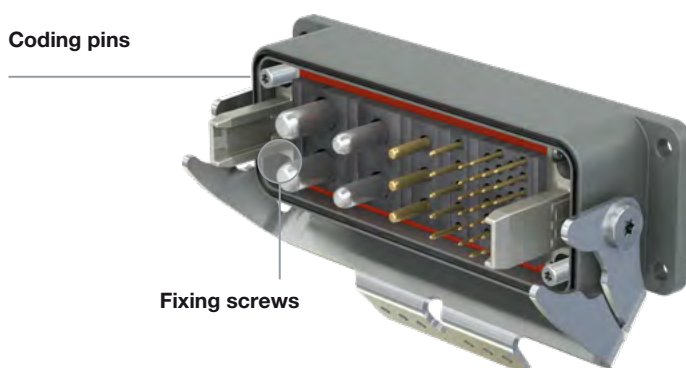

Order No.	Type
33.2887	CT-CN-GF-TORX

Coding variants

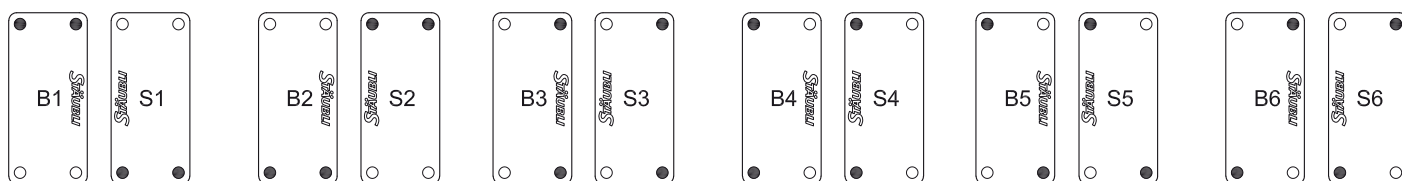

S = Pin side

B = Socket side

• = Coding pin CT-CN-GF-TORX
standard delivery

Note:

Coding B2/S2 is standard delivery, unless ordered customized.

If the contacts are arranged symmetrically, a pole reversal is possible with the following codings: S5/B5, S6/B6, S1/B2, S2/B1, S3/B4, S4/B3, S5/B6, S6/B5. Coding can nev-

ertheless be achieved by means of spacers, see page 74.

If modules of type CT-12 or CT-0.6 are included, no coding is necessary (asymmetrical configuration).

Calculation of housing size

Note:

Minimum length L = 30 mm. The maximum length L of the relevant housing size must be reached. If necessary, fill up with spacers (see page 74).

Type	Number	Width	
CT-E12		x 30 mm	=
CT-E8/6-PE, CT-E6-2		x 16 mm	=
CT-E8-2, CT-E3-.../HV..., CT-E1-26		x 18 mm	=
CT-E3-3, CT-E3/PCB, CT-E3-2+PE		x 10 mm	=
CT-E1,5-4/HV		x 8 mm	=
CT-E1,5-5, CT-E-2TH+PE		x 6 mm	=
CT-E1-15		x 20 mm	=
CT-E1-6		x 4 mm	=
CT-E0,6-20		x 5.1 mm	=
CT-LMFB		x 6 mm	=
CT-E-COAX, CT-NET		x 16 mm	=
CT-10GBIT		x 22 mm	=
CT-RJ45		x 20 mm	=
CT-E-3POF, CT-E-4GOF		x 6 mm	=
CT-E8-4		x 30 mm	=
Contact carriers	CT-E-UCT06-1	x 18 mm	=
	CT-E-UCT06-2	x 28 mm	=
	CT-E-UCT06-4, CT-E-UCT08-2	x 42 mm	=
	CT-E-UCT08-1	x 22 mm	=
further moduls			
Sum of the widths (min. 30 mm)		L	=
Housing size			
Spacers	CT-DIP0,5	x 0.5 mm	
	CT-DIP1	x 1 mm	=
	CT-DIP2	x 2 mm	=
	CT-DIP3	x 3 mm	=
	CT-DIP4, CT-DIP4/2	x 4 mm	=
further moduls			
Maximum length housing size			=

Size L (mm)	Housing size
18 ≥ L ≤ 30	1
31 ≥ L ≤ 43	2
44 ≥ L ≤ 64	3
65 ≥ L ≤ 90	4
44 ≥ L ≤ 64	5
44 ≥ L ≤ 64	
65 ≥ L ≤ 90	6
65 ≥ L ≤ 90	

↑
Maximum length L

Example

Type	Number	Width	Total		
CT-E1-26/S...	3	x 18 mm	= 54		
CT-E3-3	3	x 10 mm	= 30		
		L	= 84	Housing size	4

Fill with spacers until max. housing dimension for housing size is reached:

CT-DIP4	1	x 4 mm	= 4		
CT-DIP2	1	x 2 mm	= 2		
		Result	= 90		

Light housing for testing applications

The CombiTac IP20 plastic light housing with central locking is used in applications that require high density electrical signal connections.

The combination of up to 320 contacts, an ergonomic design with a central locking mechanism, and a removable cover while in mated condition, makes the CombiTac light housing ideal for testing applications.

Features:

- Up to 320 Ø 0.6 mm contacts
- Further combinations for signal and power with contacts up to Ø 6 mm
- 10,000 mating cycles
- 1/4 turn spring locking mechanism
- Top or side cable entry
- Adjustable cable clamp
- 36 coding possibilities

- Quick and easy cover removal for access to contacts in mated condition

Note:

Light Housing is delivered with standard coding A1 (see drawing next page). Up to 36 coding possibilities available.

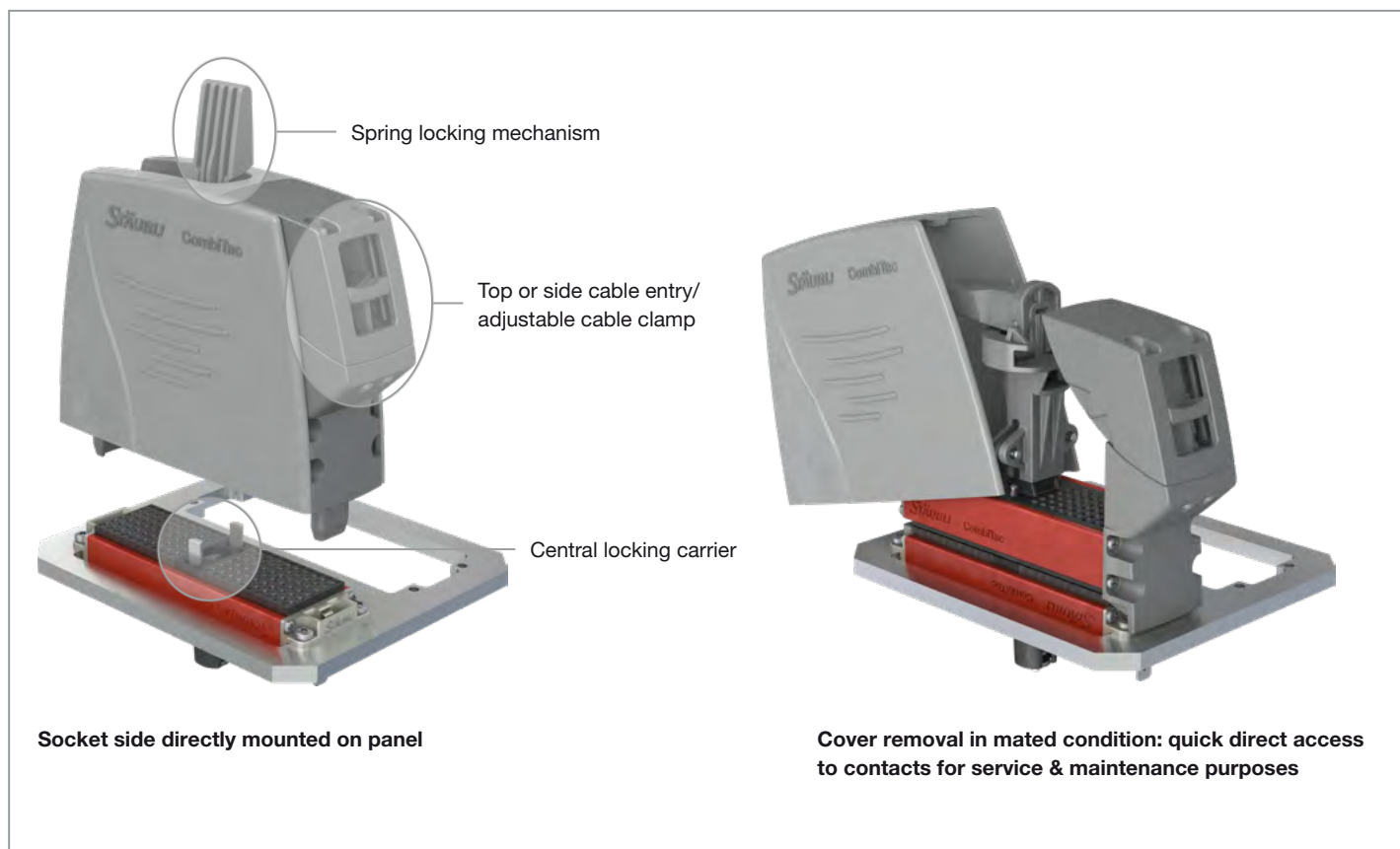

Socket side directly mounted on panel

Cover removal in mated condition: quick direct access to contacts for service & maintenance purposes

Technical data	
Degree of protection (in mated condition)	IP20
Mating cycles	10,000
Housing material	PA
Limiting temperature (IEC 61984:2008), upper	+90 °C
lower	-40 °C
Rail length	94 mm



Assembly instructions MA213-10

www.staubli.com/electrical

Housing with central locking

CT-LH4

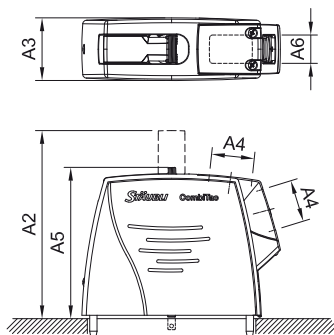

CT-ELHB

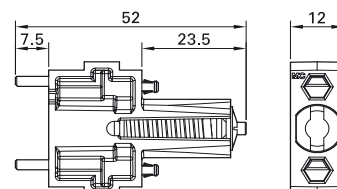

Order No.	Type	Designation	Sizes (mm)					
			A1	A2	A3	A4	A5	A6
33.2030	CT-LH4	Housing with central locking (pin side) ¹⁾	133	126	42	min. 5 – max. 24.8	101.5	19
33.2023	CT-ELHB	Central locking carrier (socket side) ¹⁾	–	–	–	–	–	–

Coding plug side

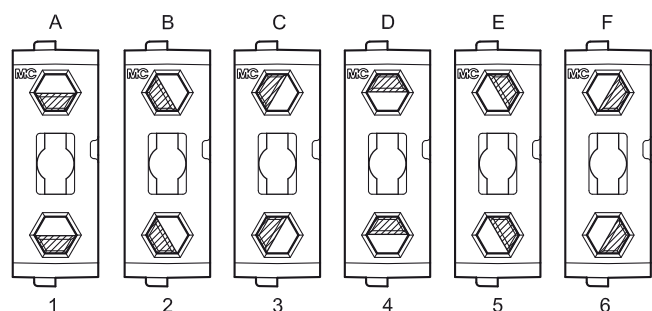

Coding socket side

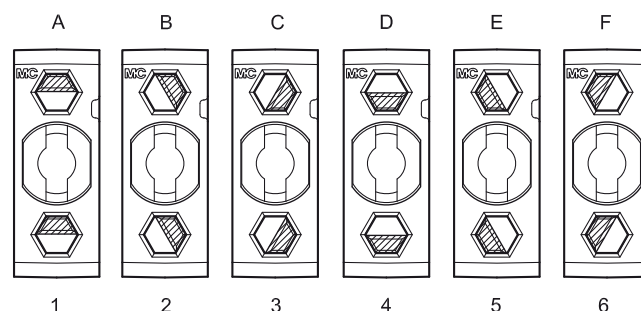

Contacts

Surface	Conductor cross section		Nom.-Ø contact mm	Rated current A
	mm ²	AWG		
For signal contacts				
	0.14 – 0.25	26 – 24	0.6	1.4 – 2
	0.25 – 0.75	24 – 18	1	2 – 5
	0.5 – 1.5	20 – 16	1.5	5 – 10
For power contacts				
	2.5 – 4	14 – 12	3	22 – 35
	6 – 16	10 – 6	6	40 – 75

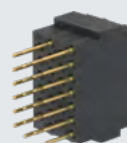

¹⁾ By selecting light housing in the CombiTac configurator, both the housing with central locking (CT-LH4) and socket side central locking carrier (CT-ELHB) are automatically added to the configuration.

CRIMPING PLIERS

Crimping the electric contacts

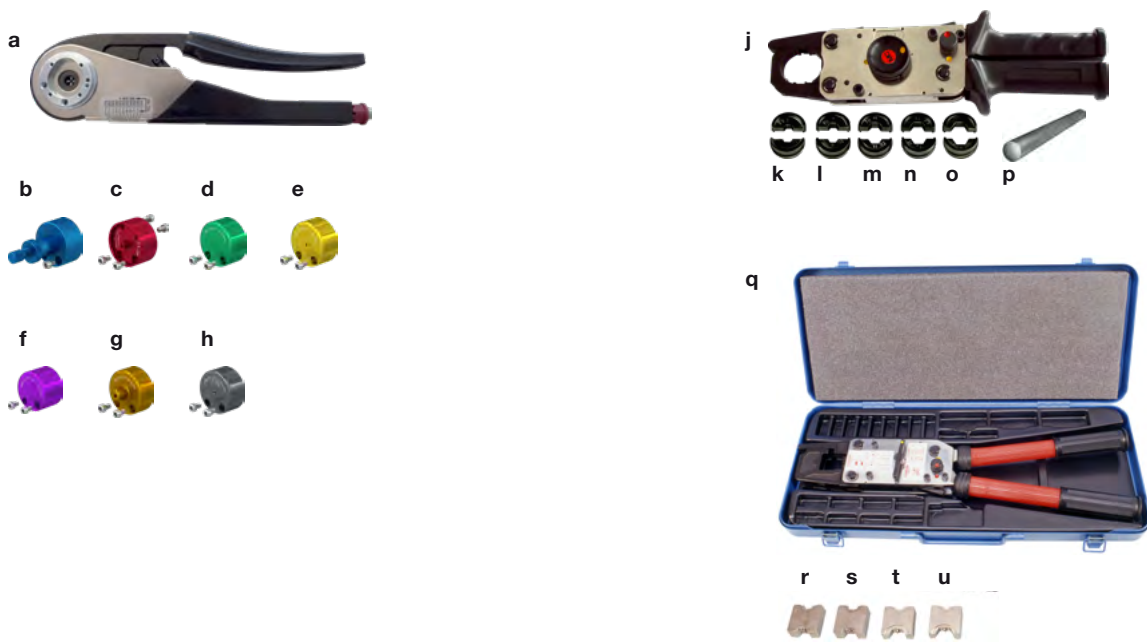

Pos.	Order No.	Type	Conductor cross section	Description	MA
			mm ²		
a	33.3800	CT-M-CZ		Crimping pliers	MA079 MA213-11
b	18.3801	MES-CZ	0.14 – 4	Locator adjustable (except for Ø 0.6 mm contacts)	MA079
c	18.3809	MES-CZ-CT0,6	0.14 – 0.25	Locator	
d	18.3804	MES-CZ-CT1	0.25 – 0.75	Locator	
e	18.3805	MES-CZ-CT1,5	0.5 – 1.5	Locator	
f	18.3810	MES-CZ-CT1,5-HV	0,5 – 1,5	Locator	
g	18.3806	MES-CZ-CT3	2.5 – 4	Locator	
h	18.3808	MES-CZ-CT0,6-COAX-RG		Locator for Coaxial unit 6 GHz	
j	18.3700	M-PZ13		Crimping pliers	MA224
k	18.3701	MES-PZ-TB5/6	6	Insert	
l	18.3702	MES-PZ-TB8/10	10	Insert	
m	18.3703	MES-PZ-TB9/16	16	Insert	
n	18.3704	MES-PZ-TB11/25	25	Insert	
o	18.3707	MPS-PZ13		Test insert	
p	18.3708	MALU-PZ13		Round test rod	MA213-01 MA226
q	18.3710	M-PZ-T2600		Crimping pliers with case	
r	18.3712	TB9-13	16 + 35	Insert	
s	18.3713	TB11-14,5	50	Insert	
t	18.3711	TB8-17	10 + 70	Insert	
u	18.3714	TB7-20	95	Insert	

Crimping the 1.5 GHz coaxial contacts



Pos.	Order No.	Type	Description	MA
a	33.3011	CT-AIWZ/COAX	Insulation stripper for Coaxial unit 1.5 GHz	MA213-02
b	33.3010	CT-CZ/COAX	Crimping pliers for shield and inner conductor for Coaxial unit 1.5 GHz	MA213-02





Crimping the plastic optical fiber contacts



Pos.	Order No.	Type	Description	MA
a	33.3021	CT-AIWZ/POF	Insulation stripper	MA213-03
b	33.3023	CT-PS/POF	Polishing disc	MA213-03
c	33.3020	CT-CZ/POF	Crimping pliers	MA065, MA213-03

ASSEMBLY TOOLS

Insertion tools socket/pin

Insertion tool	Order No.	Type	For nominal-Ø socket/pin	For contact
	33.3003	CT-E-WZ0,6	0.6 mm	
	33.3001	CT-E-WZ1-9,5	1 mm	Thermocouple contacts
	18.3003	ME-WZ1,5/2	1.5 mm	
	18.3010	ME-WZ3	3 mm	
	18.3013	ME-WZ5	6 mm	CT-POF/SL Coaxial contacts
	18.3016	ME-WZ6	8 mm	
	18.3015	MSA-WZ5 ¹⁾	6 mm	
	18.3018	MSA-WZ6 ¹⁾	8 mm	
	18.3014	MBA-WZ5 ²⁾	6/8 mm	

¹⁾ For contacts with screw connection with external thread.

²⁾ For contacts with screw connection with internal thread.

Extraction tools socket/pin

Extraction tool (socket)	Order No.	Type	For nominal-Ø pin/socket	For contact
	33.3002	CT-A-WZ0,6	0.6 mm	
	18.3001	MBA-WZ1/1,2	1 mm	
	18.3004	MBA-WZ1,5	1.5 mm	Thermocouple contacts
	33.3027	MBA-WZ3	3/4 mm	
	18.3017	MBA-WZ6	6/8 mm	
	18.3015	MSA-WZ5		Coaxial contacts
	33.3022	CT-AWZ/POF ¹⁾		POF contacts
	33.3048	CT-NET-AWZ		CT-NET contacts
	33.3006	CT-AWZ-2,5HV		

Extraction tool (pin)	Order No.	Type	For nominal-Ø pin/socket	For contact
	33.3002	CT-A-WZ0,6	0.6 mm	
	18.3002	MSA-WZ1/1,2	1 mm	
	18.3005	MSA-WZ1,5	1.5 mm	Thermocouple contacts
	33.3028	MSA-WZ4	3/4 mm	
	18.3018	MSA-WZ6	6 mm	CT-POF/SL
	18.3022	MSA-WZ8	8 mm	Coaxial contacts
	33.3006	CT-AWZ-2,5HV		

¹⁾ Extraction tool for pin and socket.

Torque wrench¹⁾



Description	Used for	Key size		Tightening torque	
		Ø 8 mm	Ø 6 mm	Ø 8 mm (M6)	Ø 6 mm (M5)
Torque wrench for hex. socket head screw	Fitting cable lug on Ø 8 and 6 mm contacts	5 mm	4 mm	3 N m ²⁾ 8.5 N m ³⁾	2 N m ²⁾ 5 N m ³⁾
Insert for cross recessed screws	Cross recessed screws for supporting rail			0.5 N m	



Description	Used for	Key size		Tightening torque	
		Ø 8 mm	Ø 6 mm	Ø 8 mm (M6)	Ø 6 mm (M5)
Torque wrench	Fitting cable lug	10 mm	8 mm	3 N m ²⁾ 8.5 N m ³⁾	2 N m ²⁾ 5 N m ³⁾
Open-end spanner ¹⁾	Fitting cable lug	8 mm	7 mm		

Special tool

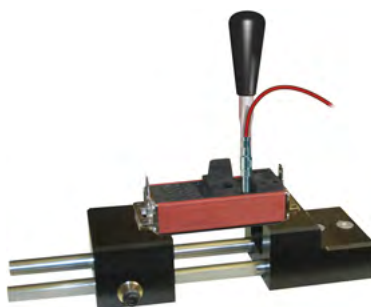
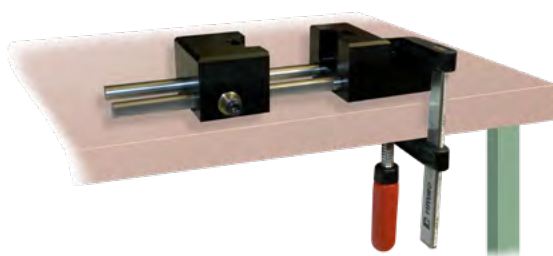

Description	Used for
Special tool CT-K-WZ 33.3040	For easy insertion of the contacts into the contact carrier. Adjustable fixing of the CombiTac units for frame sizes from 18 – 120 mm. It can be fixed on the table with a bar clamp or screws. With anti-slide surface on the underside.
Insert CT-K-WZ-AFL 33.3042	Inserting sockets into the CT-E8-2-IP2X (33.4139) contact carrier with the CT-K-WZ special tool.

¹⁾ Parts available commercially.

²⁾ For internal and external thread.

³⁾ Only for steel screws.

APPENDIX

Derating diagrams

Derating with the use of cables

The derating diagrams for cables are based on the standards IEC 60364-5-52:2009 and IEC 60512-5-2:2002. The diagrams show examples of the rated current in correlation with changes in the ambient temperature. If a CombiTac is used to equip machines, standard IEC 60204-1 is applicable instead of IEC 60364-5-52:2009.

Derating with the use of CombiTac in machines

In this case, the standard IEC 60204-1 “Safety of Machines” is applicable. This specifies the permitted current load of PVC-insulated copper wire and cables under continuous current when used in machines, at an ambient temperature of 40 °C. For bundled wires and cables under these conditions, additional reduction factors apply.

Note:

The corresponding derating current values are only for cables. The total derating current for the connector might differ from these values. When combining different module types or different cable cross sections further reductions are to be considered. A derating factor of 0.9 is already applied to the values in the diagrams.

Example 1:

1 and 2 current-carrying conductors (bundled) according to IEC 60364-5-52:2009 for 50 mm², 70 mm², and 95 mm² Cu wire, PVC insulated for higher temperatures (max. permitted conductor temperature of 90 °C).

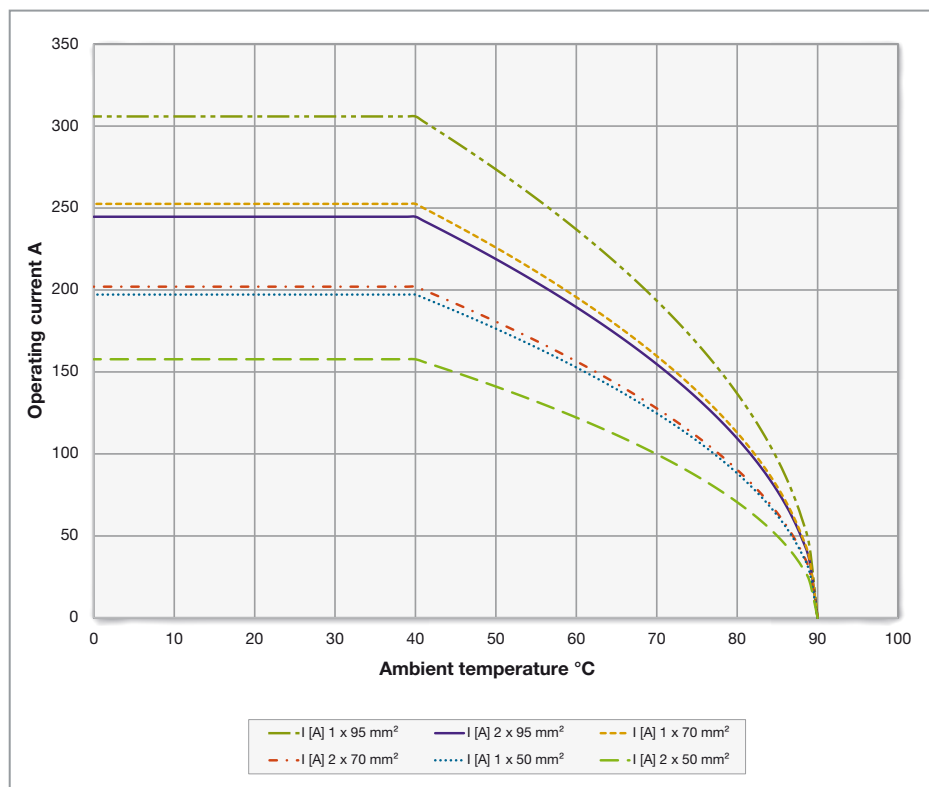

Example 2:

2 and 6 current-carrying conductors (bundled) according to IEC 60364-5-52:2009 for 25 mm², and 35 mm² Cu wire, PVC insulated for higher temperatures (max. permitted conductor temperature of 90 °C).

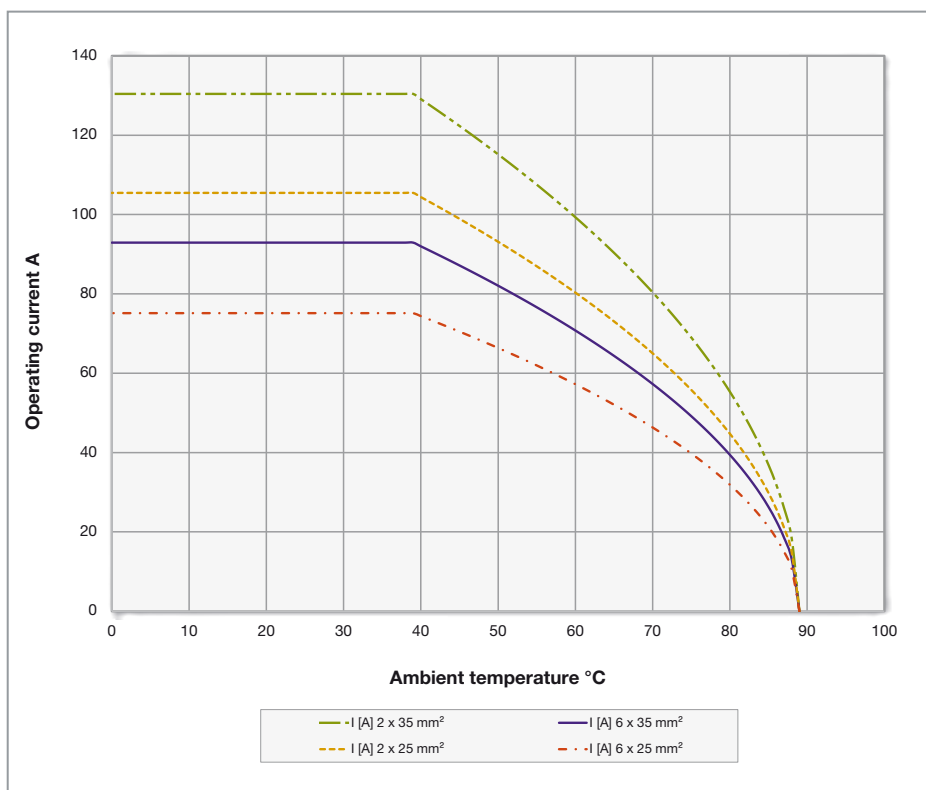

Example 3:

2 and 6 current-carrying conductors (bundled) according to IEC 60364-5-52:2009 for 10 mm², and 16 mm² Cu wire, PVC insulated for higher temperatures (max. permitted conductor temperature of 90 °C).

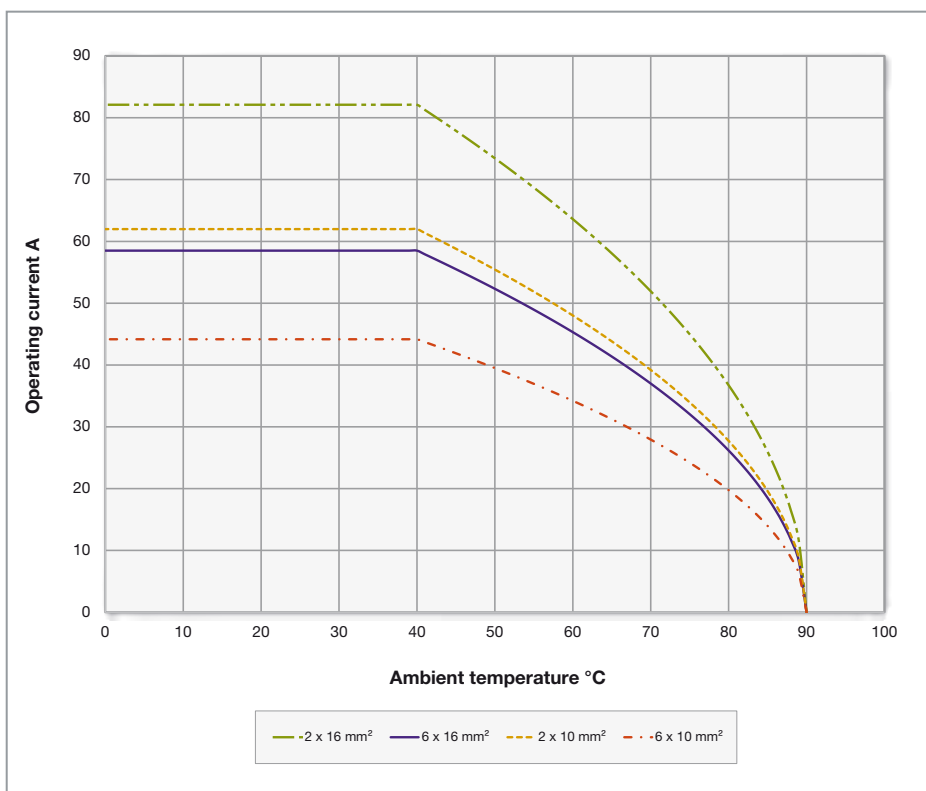

Example 4:

2 and 6 current-carrying conductors (bundled) according to IEC 60364-5-52:2009 for 2.5 mm², 4 mm², and 6 mm² Cu wire, PVC insulated for higher temperatures (max. permitted conductor temperature of 90 °C).

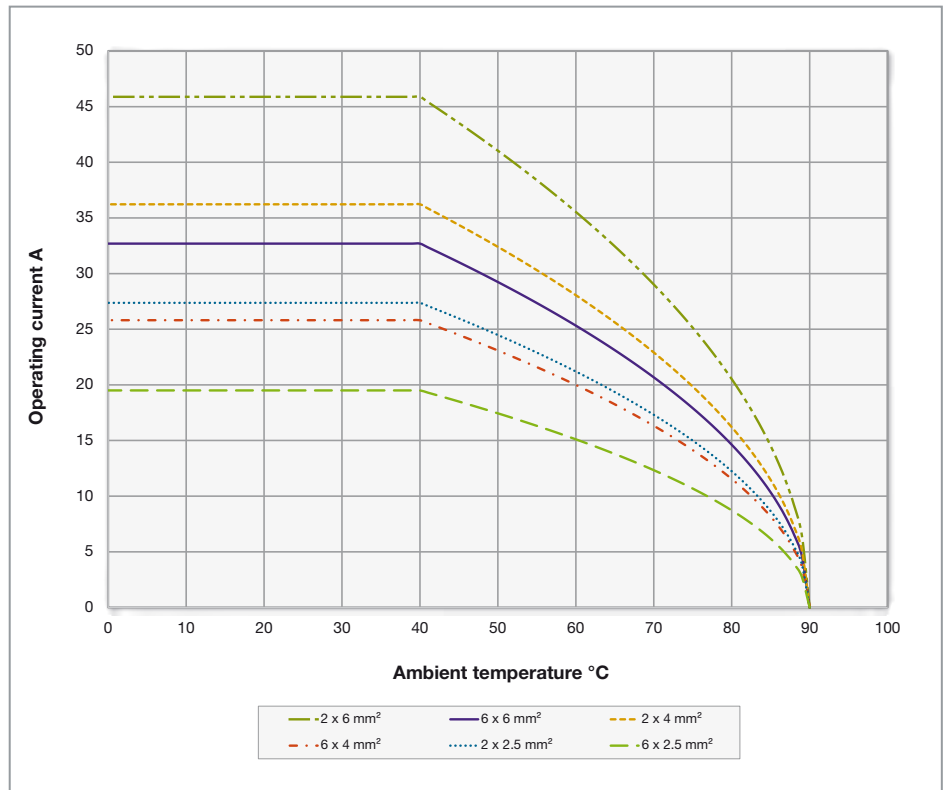

Example 5:

2, 4, and 10 current-carrying conductors (bundled) according to IEC 60364-5-52:2009 for 1 mm² and 1.5 mm² Cu wire, PVC insulated for higher temperatures (max. permitted conductor temperature of 90 °C).

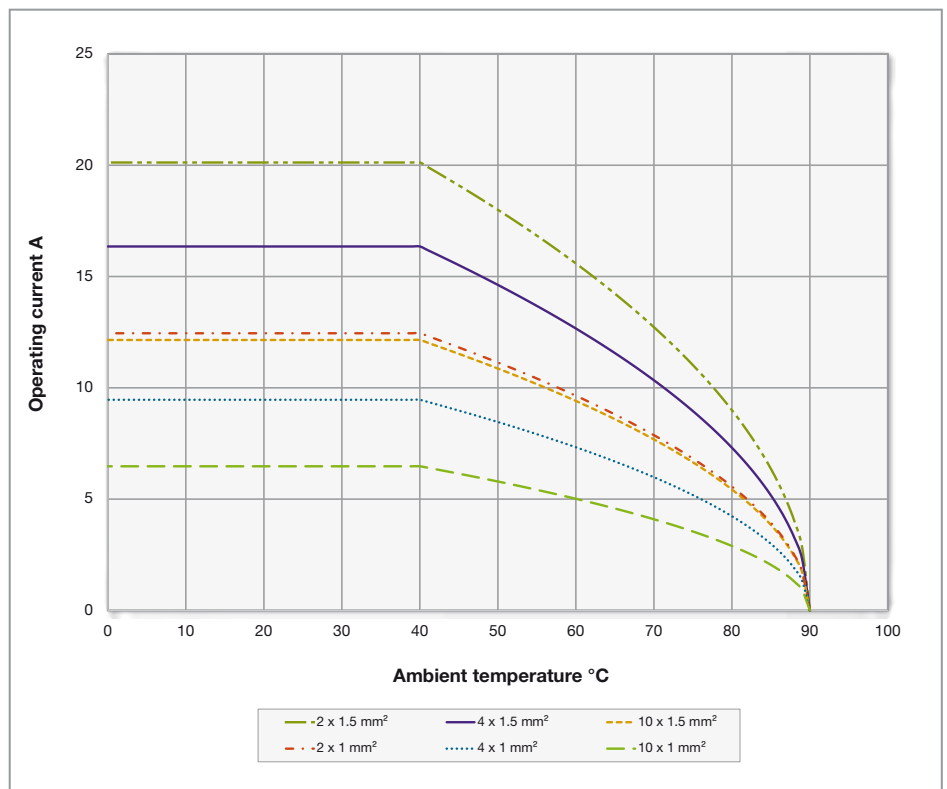

Example 6:

2, 4, 6, 10, 16, and 28 current-carrying conductors (bundled) according to IEC 60364-5-52:2009 for 0.75 mm² Cu wire, PVC insulated for higher temperatures (max. permitted conductor temperature of 90 °C).

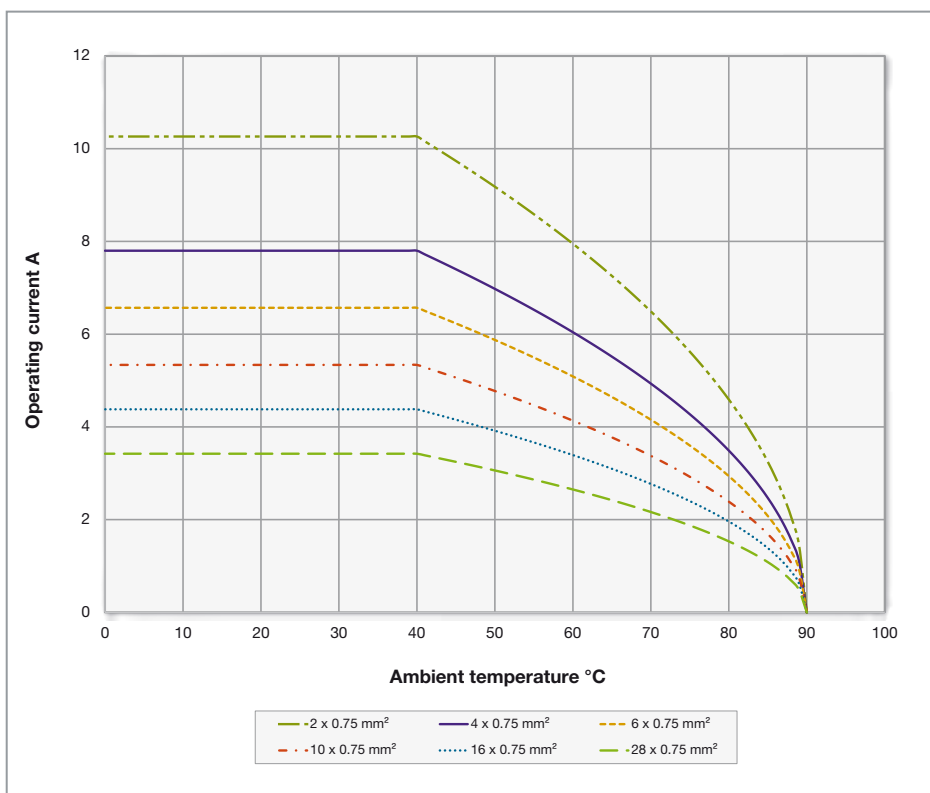

Example 7:

2, 4, 6, 10, 16, and 28 current-carrying conductors (bundled) according to IEC 60512-5-2:2002 for 0.5 mm² Cu wire, PVC insulated for higher temperatures (max. permitted conductor temperature of 90 °C).

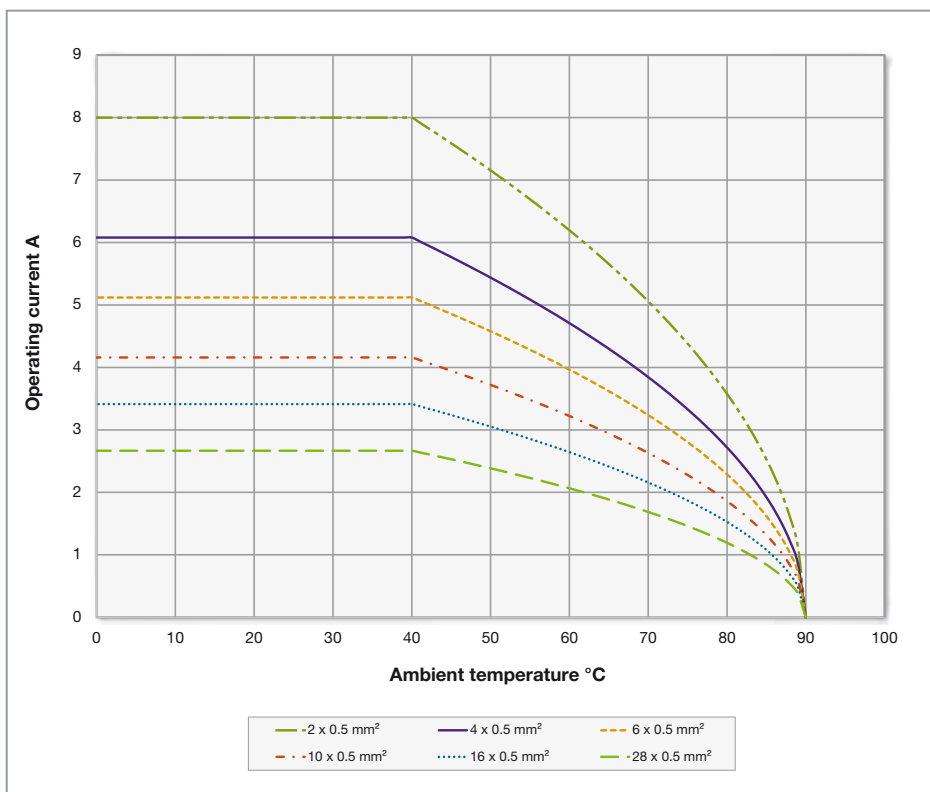

Example 8:

6, 16, 28 and 100 current-carrying conductors (bundled) according to IEC 60512-5-2:2002 for 0.25 mm² Cu wire, PVC insulated for higher temperatures (max. permitted conductor temperature of 90 °C).

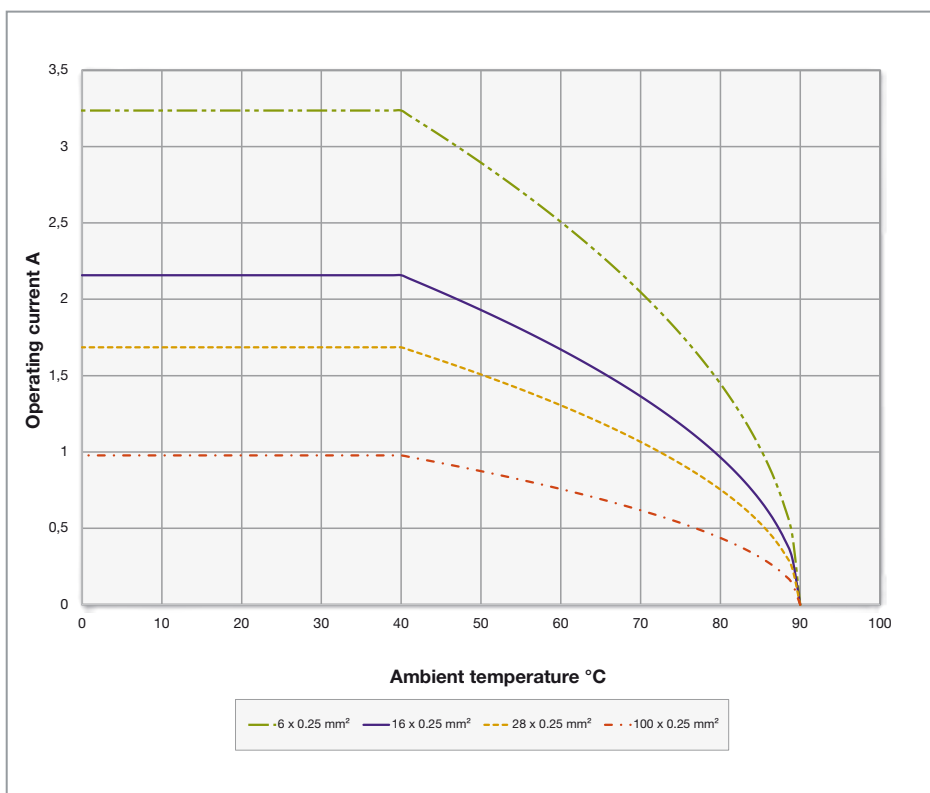

Example 9:

10, 20, 60 and 100 current-carrying conductors (bundled) according to IEC 60512-5-2:2002 for 0.14 mm² Cu wire, PVC insulated for higher temperatures (max. permitted conductor temperature of 90 °C).

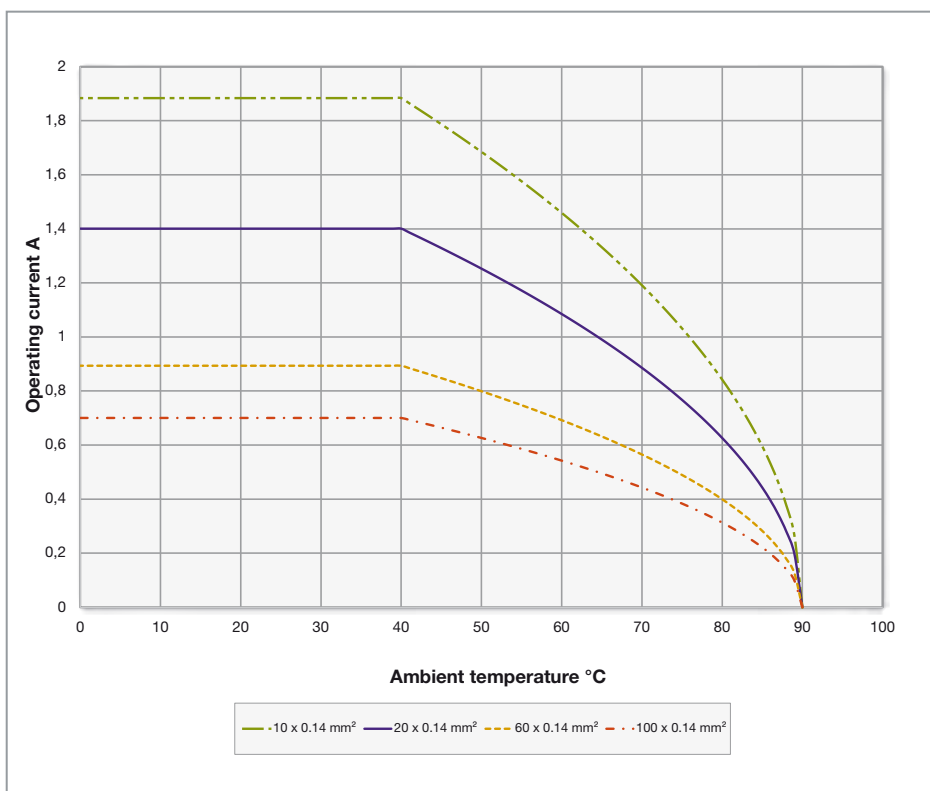

Flow, head loss diagrams, and sliding forces

Test conditions CT-...-UCT04/6, CT-...-RCT03/6

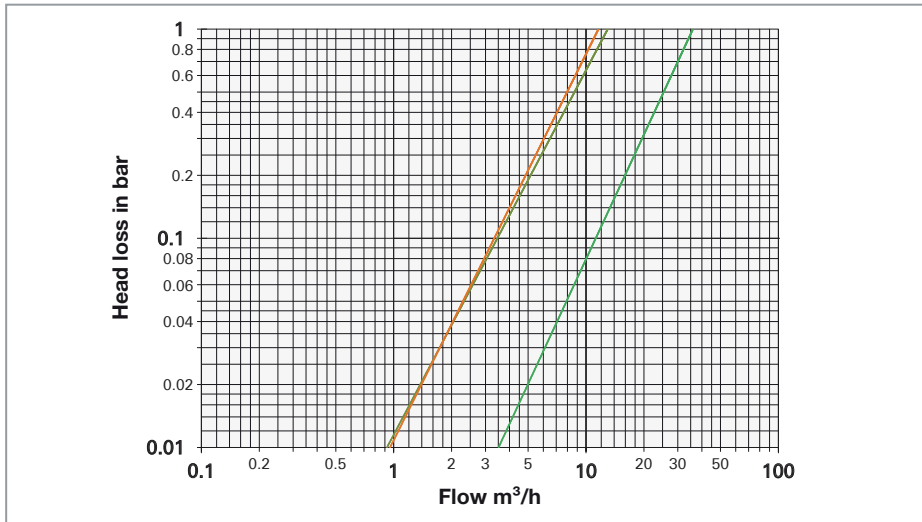

Compressed air:

Under standard conditions 0 °C, 1013 mbar

Socket	Flow direction	Plug	Max. sliding force		Input pressure	Tube-Ø
			0 bar	15 bar		
CT-B-UCT04/6 ¹⁾	→	CT-S-UCT04/6	9 N	46 N	6 bar	6 mm
CT-BV-RCT03/6 ¹⁾	→ ←	CT-S-RCT03/6	12 N	35 N	6 bar	6 mm

Test conditions CT-...-RCT03/6

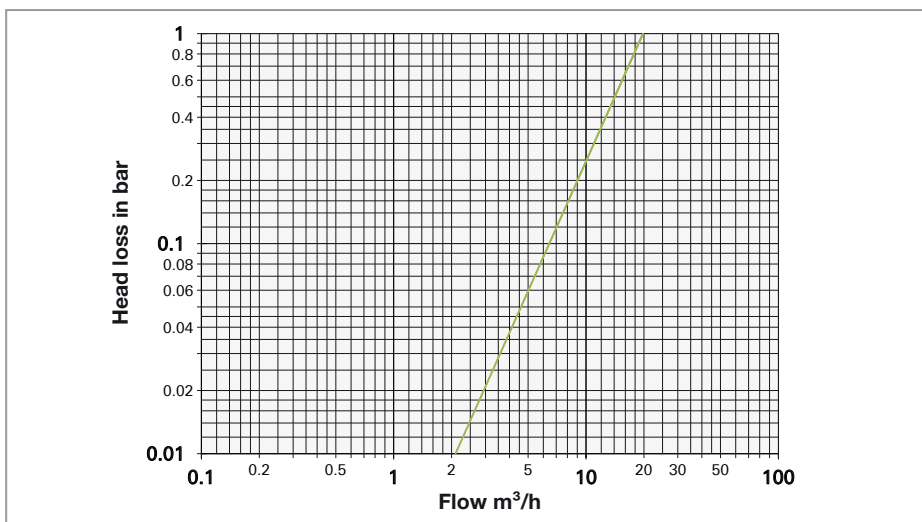

Compressed air:

Under standard conditions 0 °C, 1013 mbar

Socket	Flow direction	Plug	Max. sliding force		Input pressure	Tube-Ø
			0 bar	15 bar		
CT-B-RCT03/6	→	CT-S-RCT03/6	10 N	33 N	6 bar	6 mm

¹⁾ Without shut-off valve

Test conditions CT-...-UCT06/8

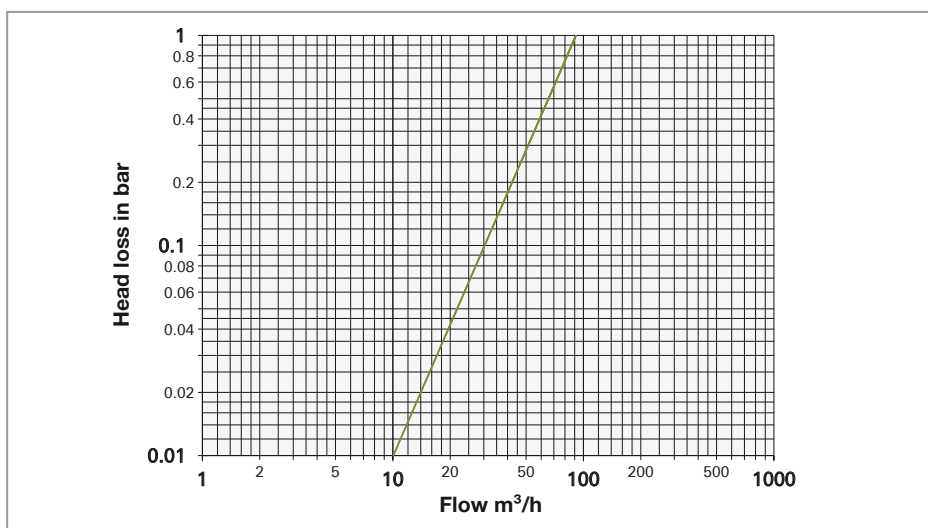

Compressed air:

Under standard conditions 0 °C, 1013 mbar

Socket	Flow direction	Plug	Max. sliding force		Input pressure	Tube-Ø
			0 bar	15 bar		
CT-B-UCT06/8		CT-S-UCT06/8	16.5 N	94 N	6	6

Test conditions CT-...-UCT08/10, CT-...-RCT06/8

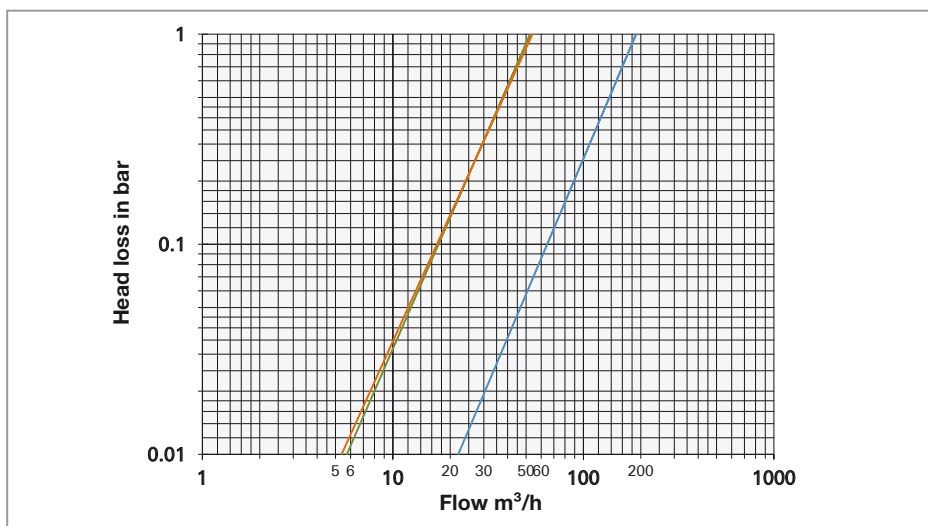

Compressed air:

Under standard conditions 0 °C, 1013 mbar

Socket	Flow direction	Plug	Max. sliding force		Input pressure	Tube-Ø
			0 bar	15 bar		
CT-B-UCT08/10 ¹⁾		CT-S-UCT08/10	16 N	134 N	6	10
CT-BV-RCT06/8		CT-S-RCT06/8	19 N	106 N	6	8

¹⁾ Without shut-off valve

Test conditions CT-...-SCT03

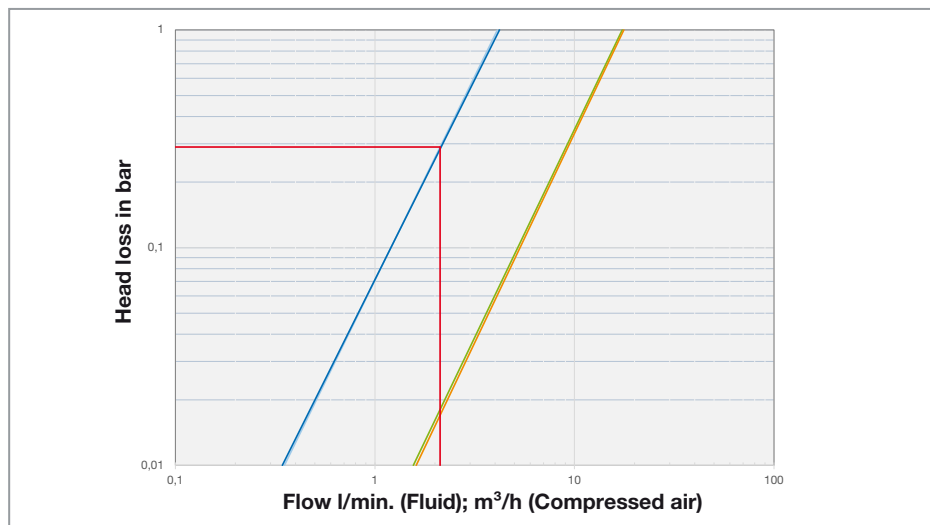

Fluid:

Water (volumetric mass 998 kg/m³).

Compressed air:

Under standard conditions 0 °C, 1013 mbar

- Hydraulic
- Pneumatic
- Flow rate 5 m/s

Socket	Flow direction	Plug	Viscosity	Input pressure	Tube-Ø
			cSt	bar	mm
CT-B-SCT03 ¹⁾²⁾		CT-S-SCT03 ¹⁾	1.08	–	6
CT-B-SCT03 ¹⁾²⁾		CT-S-SCT03 ¹⁾	–	6	6

Test conditions SCT05

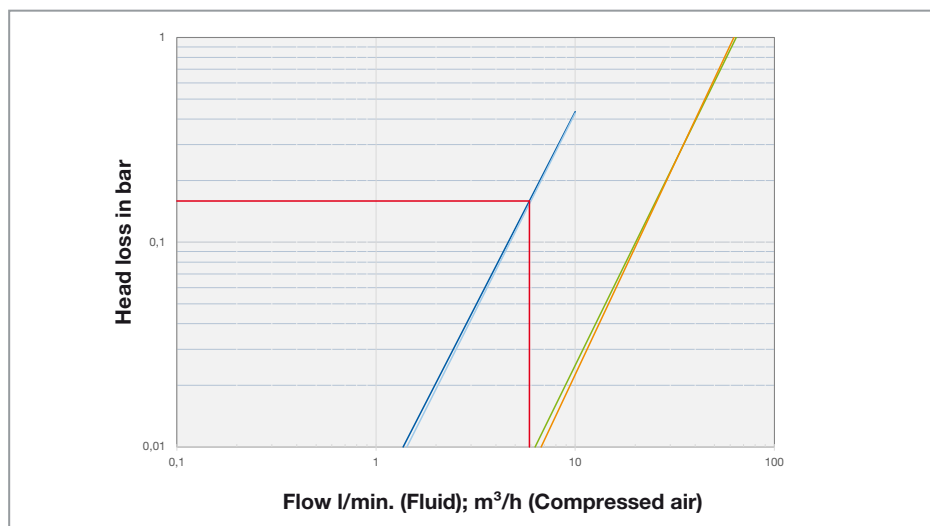

Fluid:

Water (volumetric mass 998 kg/m³).

Compressed air:

Under standard conditions 0 °C, 1013 mbar

- Hydraulic
- Pneumatic
- Flow rate 5 m/s

Socket	Flow direction	Plug	Viscosity	Input pressure	Tube-Ø
			cSt	bar	mm
CT-B-SCT05 ¹⁾²⁾		CT-S-SCT05 ¹⁾	1.08	–	8
CT-B-SCT05 ¹⁾²⁾		CT-S-SCT05 ¹⁾	–	6	8

¹⁾ Recommendation: do not engage under pressure

²⁾ Leakproof with shut-off valve

Test conditions CT-...-LCT06

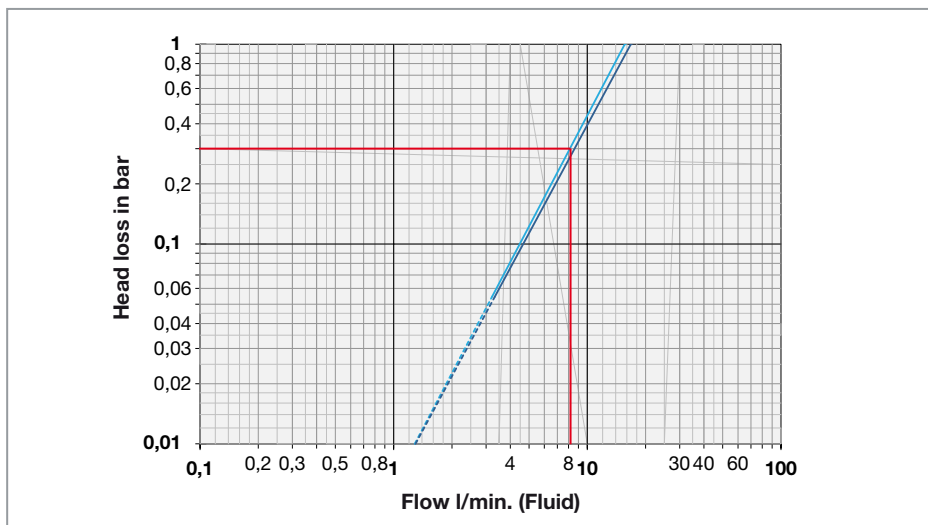

Fluid:

Water (volumetric mass 998 kg/m³).

— Hydraulic
— Flow rate 5 m/s

Socket	Flow direction	Plug	Viscosity	Input pressure	Tube-Ø
			cSt	bar	mm
CT-B-LCT06 ¹⁾²⁾	<div style="display: flex; justify-content: space-around; align-items: center;"> → ← </div>	CT-S-LCT06 ¹⁾	1.08	–	8

¹⁾ For flow, head loss diagrams, and sliding forces, see page 134.

²⁾ Lubrication interval every 20,000 mating cycles, see MA213.

Technical information

Sliding forces

The average sliding force of a CombiTac connector is the sum of all average sliding forces of the single contacts. The stated values are guideline values, and may be reduced by 20 – 30 % after a number of mating cycles.

Locking cycles DIN housing

Max. 500 locking cycles without lubrication. For up to 5,000 locking cycles, a lubrication must be executed. See note about lubrication, assembly instructions MA213.

Mating speed

CombiTac was tested at a mating speed of 600 mm/min by an automatic process.

Plugging force is equal to 1.5 times the sliding force.

Rated current

The rated current is the current, preferably at an ambient temperature of 40 °C, that each contact of the connector or connector device can carry simultaneously and permanently (without interruption).

Bundled wires

If the CombiTac is used together with bundled wires, a reduction factor must be applied to the wires. The derating diagrams on pages 127 – 131 show various examples for bundled copper wires with different cross sections that are suitable for use with CombiTac.

The listed wires are heat-resistant up to 125 °C. A conversion factor according to IEC 60364-5-52:2009, table B52.17 must be used for a certain number of bundled wires or wire types.

Rated voltage IEC 60664-1:2020

Value of voltage assigned by the manufacturer, to a component, device, or equipment and to which operation and performance characteristics are referred. Equipment may have more than one rated voltage value or may have a rated voltage range.

The rated voltages listed below correlate normatively with the following impulse withstand voltages. This is subject to the overvoltage category to be met.

Overvoltage categories

The concept of overvoltage categories is used for equipment energized directly from the low-voltage mains.

CAT II: Equipment of the overvoltage category II is energy consuming equipment to be supplied from the fixed installation. Examples of such equipment are appliances, portable tools, and other household and similar loads.

CAT III: Equipment of overvoltage category III is equipment in fixed installations and for cases where the reliability and the availability of the equipment is subject to special requirements. Examples of such equipment are switches in the fixed installation and equipment for industrial use with a permanent connection to the fixed installation.

IEC 60664-1:2020			IEC 61984:2008	
Rated voltage	Impulse withstand voltage		Test voltage: r.m.s withstand voltage 1 min, 50/60 Hz	
	Overvoltage category II	Overvoltage category III	Overvoltage category II	Overvoltage category III
< 51 V	500 V	800 V	370 V	500 V
51 V – 100 V	800 V	1500 V	500 V	840 V
101 V – 150 V	1500 V	2500 V	840 V	1390 V
151 V – 300 V	2500 V	4000 V	1390 V	2210 V
301 V – 600 V	4000 V	6000 V	2210 V	3310 V
601 V – 1000 V	6000 V	8000 V	3310 V	4260 V

Protective conductor PE (IEC 61140:2016)

Conductor provided for purposes of safety, for example protection against electric shock. Marking of the protective bonding terminal with letter PE, or color combination green-yellow, or graphical symbol. Connect this terminal to the protective-equipotential-bonding system of the installation.

Pollution degree 2 IEC 60664-1:2020

Normally only nonconductive pollution occurs. Occasionally, however, temporary conductivity caused by condensation is to be expected.

Pollution degree 3 IEC 60664-1:2020

Presence of conductive pollution or of dry nonconductive pollution that becomes conductive due to condensation that is to be expected.

Connector resistance

The connector resistance is determined by means of the voltage drop, measured between the lead terminations of the pin and socket. The values given are average values determined at rated current.

Mating cycles

Mating cycles tests for CombiTac parts are performed under typical laboratory environmental conditions.

Limiting temperature

The limiting temperatures specified in this catalog apply to CombiTac connectors in mated condition.

RoHS Conformity

European Directive 2011/65/EU (RoHS 2)

Commission Delegated Directive (EU) 2015/863 (RoHS 3)

For further information please visit our website

www.staubli.com/global/en/electrical-connectors/downloads/certificates/rohs-conformity.html

Safety notes

Protection against electric shock

A connector shall be so designed that, after mounting, its live parts are not accessible by the IEC test finger in accordance with clause 5 of IEC 60529:2013 using a test force of 20 N. These products are designed to be built into a housing that guarantees the relevant IP protection for cable connections (at least IP2X). Protection against electric shock must be provided by the end product and ensured by the users themselves. This requirement does not apply to a connector operated with a safety extra-low voltage (SELV) of a maximum AC 50 V eff. or DC 120 V. The customer must take appropriate measures when fitting the connectors to ensure that the cable connection is protected against tension and twisting and is responsible for correct implementation of the contact-protection measures.

Connecting and disconnecting when live is permitted.

Connecting and disconnecting under load is not permitted.

Enclosure

An enclosed connector is a connector for which the protection against electric shock is ensured by the housing of the connector itself. An unenclosed connector is a connector for which the protection against electric shock is provided by the enclosure of the equipment in which the connector is mounted.

In relation to the direction of power flow, connectors should be incorporated in the circuit wiring in such a way that pins that can be touched are not live in the unmated state (IEC 61984:2008).

Protection wall

In order to meet the requirement for protection against accessibility of live parts during connecting and disconnecting, CombiTac is provided with a specially designed protection wall.

Electrical contacts in close proximity to connectors for liquids and gases

Defect electrical contacts or connectors that leak gas or liquids can be a safety hazard to personnel, the environment, as well as affecting the proper function of the system. It is the responsibility of the end-user to ensure that both safety and proper function in the end-use is guaranteed. The result of a risk analysis requires that the end-user of CombiTac connectors must ensure the following:

- All relevant national and international standards and regulations must be complied with in the end-use.
- Field-tested techniques must be applied and, a risk assessment must be carried out in order to identify and reduce the risks.
- The use of flammable or explosive liquids or gases is prohibited.
- Exclusively CT-...SCT couplings with both male and female-sided locking systems are permitted to be used for liquids.
- Automatic disconnection of power supply in the event of indirect contact, overload, or short circuit is required according to IEC 60364-4-41:2017.
- If the voltage is higher than AC 50 V or DC 120 V, all simultaneously accessible conductive parts that do not carry current during normal operation must be connected to the protective conductor (protective equipotential bonding according to IEC 60364-4-41:2017).
- If the voltage is higher than AC 50 V or DC 120 V, all electric circuits have to be protected by a residual-current-operated protective device (RCD) with a rated residual operating current not exceeding 30 mA according to IEC 60364-4-41:2017.
- Connecting or disconnecting under load or live is not allowed (connector without breaking capacity according to IEC 61984:2008).

- On permanently fixed installations, electrical contacts have to be placed above liquid couplings.
- In CombiTac housing applications, the housing has to be connected to the protective conductor according to IEC 60364-4-41:2017.
- The fluid couplings must be replaced if a leak is detected.

Underwriters Laboratories

Standard UL 1977 states:

A connector operated above 30 V (42 V peak) up to AC/DC 600 V intended for usage external to the end equipment shall have live parts protected against exposure to contact by persons when assembled, installed, and mated as intended, as determined by the use of the articulate probe with web stop (UL test finger).

Mating devices operated above 30 V up to AC/DC 600 V intended for usage external to the end equipment shall not have exposed live contacts during engagement or withdrawal, as determined by the use of the articulate probe with web stop (UL test finger).

Safety situation for CombiTac connectors

Engaged or disengaged when CombiTac is isolated from supply

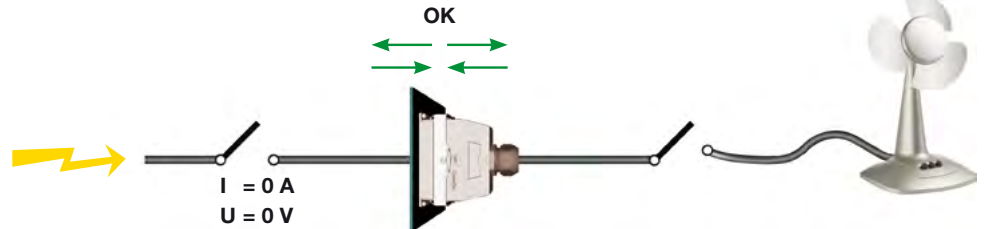

Engaged or disengaged when live and under no load

With protection wall

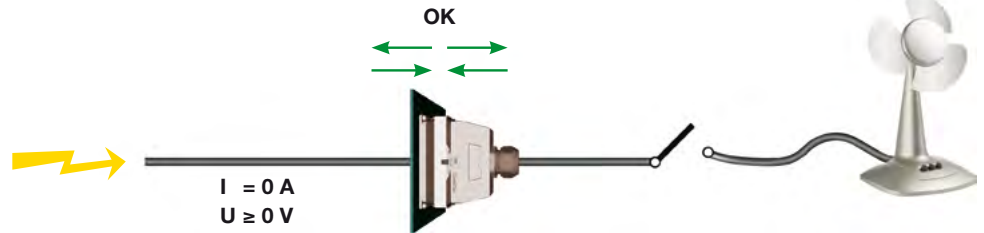

⚠ Attention

When disengaged, the socket side is touch protected, i.e. has IP2X protection according to IEC 60529:2013 (test finger). See also page 138 of the CombiTacline catalog, section "Underwriters Laboratories standard UL 1977".

ing to IEC 60529:2013 (test finger). See also page 138 of the CombiTacline catalog, section "Underwriters Laboratories standard UL 1977".

Engaged or disengaged when live and under load

With or without protection wall

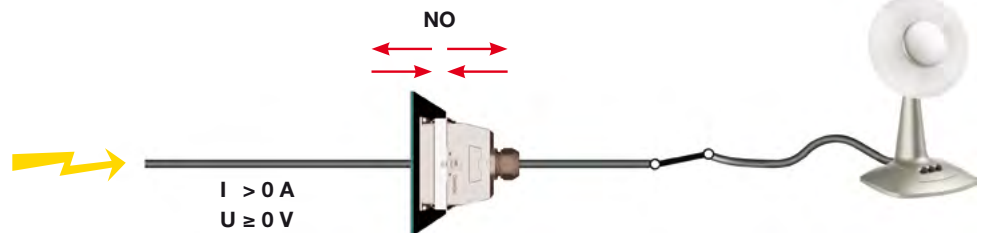

Panel-mounted version

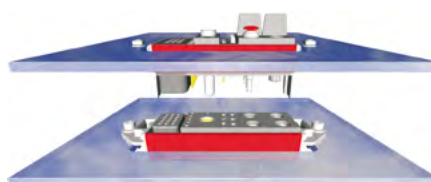

The protection against electric shock is provided by the enclosure of the equipment in

which it is installed. This is provided by the CombiTac end-user.

Applications

CombiTac in an automated radio testing station for the automotive industry.
The connector solution consists of signal, coaxial and fiber optic contacts.

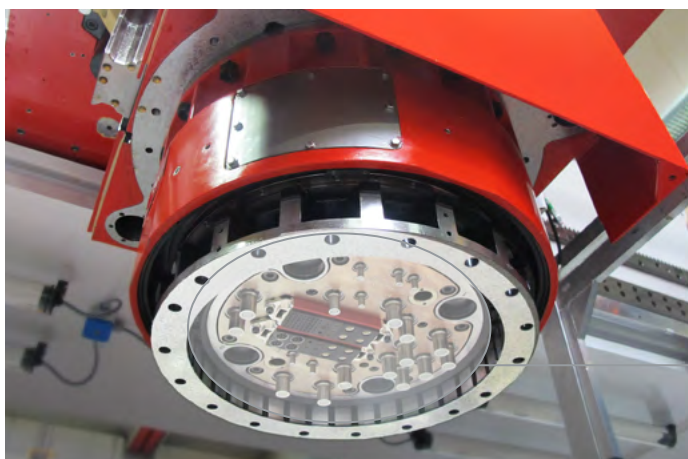
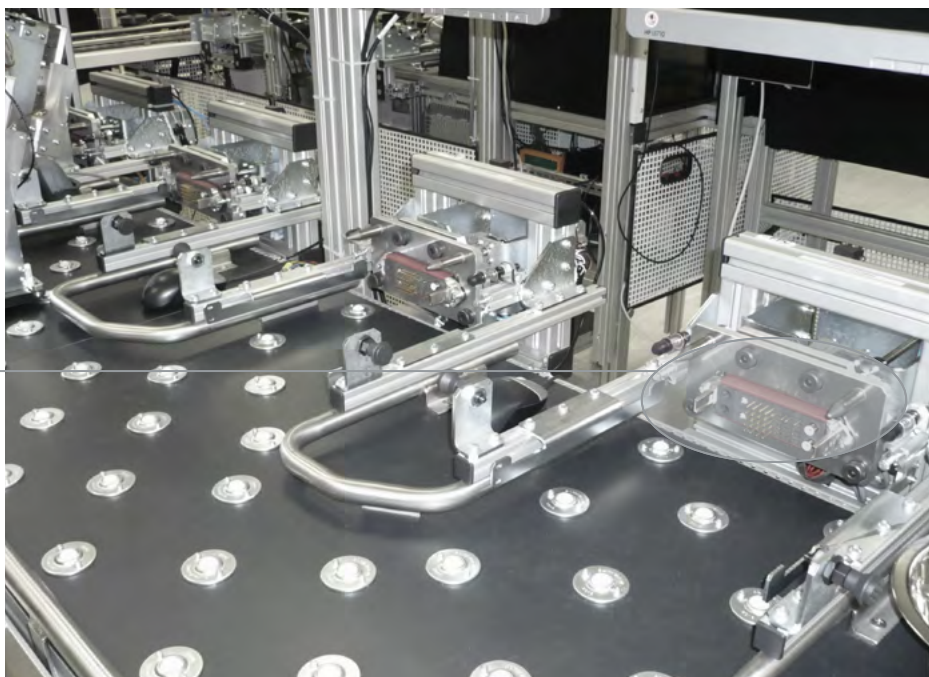
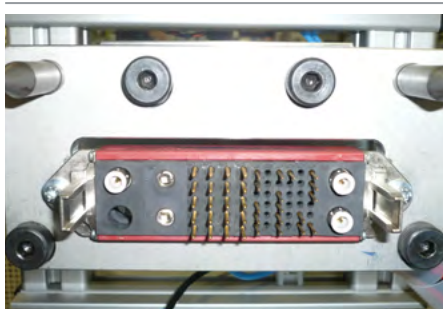

Connector solution with CombiTac for plate mounting, to create a connection between the various milling head units and the drive.

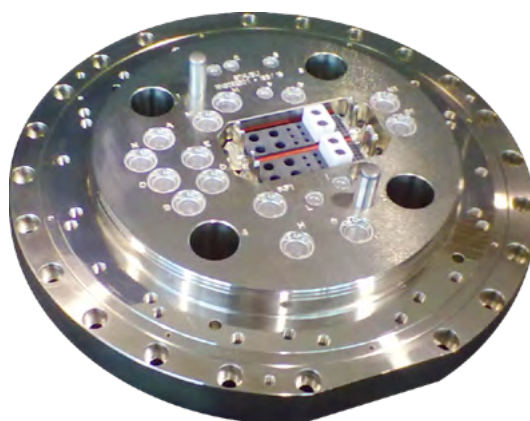



CombiTac in a modular test bench for the testing and simulation of electric components.



CombiTac for connections to mobile trolleys in operation rooms for medical technology.

CombiTac in Multi Coupling Systems (MCS)

The MCS principle allows you to centralize your different connections (power, signal, pneumatics, hydraulics, etc.) and get instant energy thanks to a much easier and reliable coupling procedure.

Such automatic or manually operated quick disconnect systems allow standard components to be mounted onto carrier plates and several energies to be connected or disconnected simultaneously.

MCS plates are commonly used in high-performance applications that demand reliability and repeatability, such as connections for test benches, injection moulding tools, transfer tables, and converters, etc.



MCS plates: the optimal combination of
high-performance solutions

UNLIMITED POSSIBILITIES FOR CONTACT SOLUTIONS

MULTILAM Technology



MULTILAM are specially formed and resilient contact elements. All Stäubli Electrical Connectors products benefit from the unique and outstanding performance of the MULTILAM Technology.

Thanks to their constant spring pressure, MULTILAM louvers ensure continuous contact with the contact surface, resulting in a constantly low contact resistance.

MULTILAM Technology allows to find solutions for connectors within the severest constraints and in certain products for up to 1 million mating cycles.

This makes the MULTILAM Technology the best choice for applications with demanding requirements:

- Reliable and longlife operation due to constantly high performance
- Safe operation under highest environmental demands on temperature, vibration and shock
- Suitable for data and signal contacts as well as high-current connectors
- Automated solutions with a high number of mating cycles

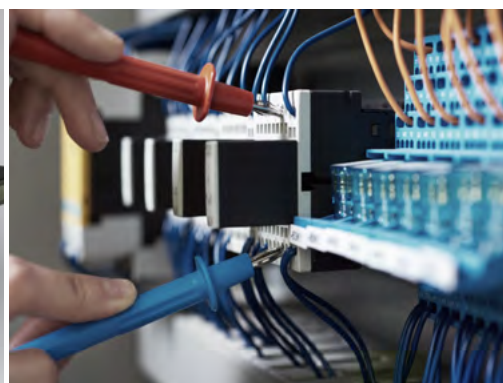



Index

Type	Page
CT-10GBIT-M12/B	49
CT-10GBIT-M12/S	49
CT-10GBIT-RJ45/B	49
CT-10GBIT-RJ45/S	49
CT-AG1 IP68 HE	102
CT-AG1 TP	108
CT-AG1TP PS/B	110
CT-AG1TP PS/S	110
CT-AG2 IP68 HE	102
CT-AG2 TP	108
CT-AG2TP PS/B	110
CT-AG2TP PS/S	110
CT-AG3 IP68 HE	102
CT-AG3 TP	108
CT-AG3TP PS/B	110
CT-AG3TP PS/S	110
CT-AG4 IP68 HE	102
CT-AG4 TP	108
CT-AG4TP PS/B	110
CT-AG4TP PS/S	110
CT-AIWZ/COAX	123
CT-AIWZ/POF	123
CT-A-WZ0,6	125
CT-AWZ-2,5HV	125
CT-AWZ/POF	125
CT-B0,6ET/LO AU	39
CT-B0,6ET/PCB AU	39
CT-B1,5LAV/PCB AU	33
CT-B1ET/PCB AU	37
CT-B1/PCB AU	37
CT-B3/PCB-K AU	25
CT-B6/M5A AG	23
CT-B6/M5 AG	23
CT-B6/M5A/PE AG	21
CT-B8/M6A AG	19
CT-B8/M6A AU	19
CT-B8/M6 AG	19
CT-B8/M6A/PE AG	21
CT-B8/M6 AU	19
CT-B8/M8A/PE-L AG	16

Type	Page
CT-B12/M10 AG	12
CT-B/COAX58	45
CT-B/COAX59	45
CT-B-COAX-RG58	43
CT-B-COAX-RG316/U	43
CT-B-COAX-SMA	43
CT-BE-B	78
CT-BE-B/4	77
CT-BEG-B	78, 113
CT-BEG-S	78, 113
CT-BE-S	78
CT-BE-S/4	77
CT-BESZ-B	78
CT-BESZ-S	78
CT-B/GOF	55
CT-B/GOF-025-FSMA	55
CT-B/GOF-100-SC	55
CT-B/GOF-100-ST	55
CT-B-LCT06	73
CT-BP0,6ET/0,14-0,25 AU	39
CT-BP1,0,25-0,75 AU	37
CT-BP1,5/0,5-1,5-HV	31
CT-BP1,5LAV/0,5-1,5 AU	33, 59
CT-BP1,5LAV/1,5 AU	33
CT-BP1ET/0,25-0,75 AU	37
CT-BP3/2,5-4 AU	25, 27
CT-BP3/2,5-4/PE AU	27
CT-BP3/2,5-HV AU	29
CT-BP6/6 AG	23
CT-BP6/10 AG	23
CT-BP6/16 AG	23
CT-BP6/16/PE AG	21
CT-BP8/10 AG	19
CT-BP8/10 AU	19
CT-BP8/16 AG	19
CT-BP8/16 AU	19
CT-BP8/25 AG	19
CT-BP8/25 AU	19
CT-BP8/25/PE AG	21
CT-BP8/25/PE-L AG	15

Type	Page
CT-BP8/35 AG	19
CT-BP8/35/PE-L AG	15
CT-BP8/50/PE-L AG	15
CT-BP10/10/PE-GND AG	115
CT-BP10/16/PE-GND AG	115
CT-BP10/25/PE-GND AG	115
CT-BP10/35/PE-GND AG	115
CT-BP10/50/PE-GND AG	115
CT-BP10/AWG4/PE-GND AG	115
CT-BP12/50 AG	11
CT-BP12/70 AG	11
CT-BP12/95 AG	11
CT-B/POF	53
CT-B-RCT03/1/4"	63
CT-B-RCT03/4	63
CT-B-RCT03/6	63
CT-B-RCT03/PLV 2/4	63
CT-B-RCT03/PLV4/6	63
CT-BS	78
CT-BS1	37
CT-BS8	19, 45
CT-BS-AL	78
CT-B-SCT03	69
CT-B-SCT05	71
CT-BSGOF	41, 55
CT-BTG-B	78
CT-BTG-S	78
CT-B-UCT04/1/4"	63
CT-B-UCT04/6	63
CT-B-UCT06/8	65
CT-B-UCT08/3/8"	67
CT-B-UCT08/10	67
CT-BV-RCT03/1/4"	63
CT-BV-RCT03/4	63
CT-BV-RCT03/6	63
CT-BV-RCT03/PLV 2/4	63
CT-BV-RCT03/PLV4/6	63
CT-BV-RCT06/8	67
CT-BV-RCT06/PLV6/8	67
CT-BV-RCT06/PLV8/10	67

Type	Page
CT-CH1-S	86
CT-CH1-T	86
CT-CH2-S	86
CT-CH2-S/PW	89
CT-CH2-S/PW-PC	89
CT-CH2-S/SSL	98
CT-CH2-T	86
CT-CH2-T/PW	89
CT-CH2-T/PW-PC	89
CT-CH2-T/SSL	98
CT-CH2/ZV-R	104
CT-CH3-S	86
CT-CH3-S/PW	89
CT-CH3-S/PW-PC	89
CT-CH3-S/SSL	98
CT-CH3-T	86
CT-CH3-T/PW	89
CT-CH3-T/PW-PC	89
CT-CH3-T/SSL	98
CT-CH3/ZV-R	104
CT-CH4-S	86
CT-CH4-S/PW	89
CT-CH4-S/PW-PC	89
CT-CH4-S/SSL	98
CT-CH4-T	86
CT-CH4-T/PW	89
CT-CH4-T/PW-PC	89
CT-CH4-T/SSL	98
CT-CH4/ZV-R	104
CT-CH5-S	86
CT-CH5-S/PW	89
CT-CH5-S/PW-PC	89
CT-CH5-T	86
CT-CH5-T/PW	89
CT-CH5-T/PW-PC	89
CT-CH6-S	86
CT-CH6-S/PW	89
CT-CH6-S/PW-PC	89
CT-CH6-T	86
CT-CH6-T/PW	89

Type	Page
CT-CH6-T/PW-PC	89
CT-CHG1-T	87
CT-CHG2-T	87
CT-CHG2-T/PW	87
CT-CHG3-T	87
CT-CHG3-T/PW	87
CT-CHG4-T	87
CT-CHG4-T/PW	87
CT-CHG5-T	87
CT-CN-GF-TORX	118
CT-CZ/COAX	123
CT-CZ/POF	123
CT-DDI-SM2	95, 101
CT-DDI-SM3	95, 101
CT-DDI-SM4	95, 101
CT-DIP0,5	74
CT-DIP1	74
CT-DIP1,3-3,4	39
CT-DIP2	74
CT-DIP3	74
CT-DIP4	74
CT-DIP4/2	16, 74
CT-E0,6-20/B	38
CT-E0,6-20/S	38
CT-E1,5-4/HV-B	30
CT-E1,5-4/HV-S	30
CT-E1,5-5	32
CT-E1-6	36
CT-E1-15/B	35
CT-E1-15/S	35
CT-E1-26/B	34
CT-E1-26/S	34
CT-E-2TH+PE/B	58
CT-E-2TH+PE/S	58
CT-E3-1/HV-B	28
CT-E3-1/HV-S	28
CT-E3-2+PE/B	26
CT-E3-2+PE/S	26
CT-E3-2/HV-B	28
CT-E3-2/HV-S	28

Type	Page
CT-E3-3	24
CT-E3-3/B	24
CT-E3-3/PCB	24
CT-E3-3/PCB/B	24
CT-E-3POF/B	52
CT-E-3POF/S	52
CT-E-4GOF	54
CT-E6-2	22, 52
CT-E8-2	18, 44, 62, 68
CT-E8-2-IP2X	18
CT-E8-4/B	62, 68
CT-E8-4/S	62, 68
CT-E8/6-PE	14, 20
CT-E12-1/B	10
CT-E12-1/S	10
CT-E-COAX-1	42
CT-E-COAX-2	42
CT-ELHB	121
CT-E-SCT03-2	68
CT-E-UCT06-1	64
CT-E-UCT06-2	64
CT-E-UCT06-4	64
CT-E-UCT08-1	66, 70, 72
CT-E-UCT08-2	66, 70, 72
CT-E-WZ0,6	124
CT-E-WZ1-9,5	124
CT-E-ZV/B/TG2	104
CT-E-ZV/B/TG3	104
CT-E-ZV/B/TG4	104
CT-E-ZV/S	104
CT-GND10 AG	114
CT-HV-SRTU	29
CT-K-VSH M25x9,5-12,5 MS	13
CT-K-VSH M25x10-17 MS	13
CT-K-VSH M25x16-20,5 MS	13
CT-K-VSH M32x17-21 MS	13
CT-K-VSH M32x21-25,5 MS	13
33.4125	13
CT-K-WZ	126
CT-K-WZ-AFL	126

Type	Page
CT-LH4	121
CT-LMFB/B	40
CT-LMFB-B2/0,5-1,5 AU	41
CT-LMFB/S	40
CT-LMFB-S2/0,5-1,5 AU	41
CT-M-CZ	122
CT-NET-1/B	46
CT-NET-1/S	46
CT-NET-2/B	46
CT-NET-2/S	46
CT-NET-AWZ	125
CT-NET-BP1 ET/0,14-0,75 AU	47
CT-NET-BS	47
CT-NET-SP1/0,14-0,75 AU	47
CT-PC1 IP68 HE	103
CT-PC2 IP68 HE	103
CT-PC3 IP68 HE	103
CT-PC4 IP68 HE	103
CT-PC-SM1-L/FSCH	96
CT-PC-SM2-L/FSCH	96
CT-PC-SM3-L/FSCH	96
CT-PC-SM4-L/FSCH	96
CT-PC-SM5-L/FSCH	96
CT-PC-SM6-L/FSCH	96
CT-PDI-SM2	95, 101
CT-PDI-SM3	95, 101
CT-PDI-SM4	95, 101
CT-PM1	93
CT-PM1-PC	93
CT-PM2	93
CT-PM2-PC	93
CT-PM2/PW	93
CT-PM3	93
CT-PM3-PC	93
CT-PM3/PW	93
CT-PM4	93
CT-PM4-PC	93
CT-PM4/PW	93
CT-PM5	93
CT-PM5-PC	93

Type	Page
CT-PM5/PW	93
CT-PM6	93
CT-PM6-PC	93
CT-POF/SL	53
CT-PS1-SM/P	95
CT-PS1-SM/S	95
CT-PS2/PC-SM/S	95
CT-PS2-SM/P	95
CT-PS2-SM/S	95
CT-PS2-SM/SSL/P	100
CT-PS2-SM/SSL/S	100
CT-PS3/PC-SM/S	95
CT-PS3-SM/P	95
CT-PS3-SM/S	95
CT-PS3-SM/SSL/P	100
CT-PS3-SM/SSL/S	100
CT-PS4/PC-SM/S	95
CT-PS4-SM/P	95
CT-PS4-SM/S	95
CT-PS4-SM/SSL/P	100
CT-PS4-SM/SSL/S	100
CT-PS5/PC-SM/S	95
CT-PS5-SM/P	95
CT-PS5-SM/S	95
CT-PS6/PC-SM/S	95
CT-PS6-SM/P	95
CT-PS6-SM/S	95
CT-PS/POF	123
CT-RC12	10
CT-RC-COAX	42
CT-RJ45/B	50
CT-RJ45/S	50
CT-S0,6/LO AU	39
CT-S0,6/PCB AU	39
CT-S1,5/PCB-K AU	33
CT-S1,5/PCB-L AU	33
CT-S1/PCB-K AU	37
CT-S1/PCB-L AU	37
CT-S3/PCB-K AU	25
CT-S3/PCB-L AU	25

Type	Page
CT-S6/M5A AG	23
CT-S6/M5 AG	23
CT-S6/M5A/PE AG	21
CT-S8/M6A AG	19
CT-S8/M6A AU	19
CT-S8/M6 AG	19
CT-S8/M6A/PE AG	21
CT-S8/M6 AU	19
CT-S8/M8A/PE-L AG	16
CT-S12/M10 IP2X AG	12
CT-SC0,8	41
CT-S/COAX58	45
CT-S/COAX59	45
CT-S-COAX-RG58	43
CT-S-COAX-RG316/U	43
CT-S-COAX-SMA	43
CT-SD-AG1 TP	109
CT-SD-AG2 TP	109
CT-SD-AG3 TP	109
CT-SD-AG4 TP	109
CT-SG1 IP68 HE	103
CT-SG1 TP	109
CT-SG2 IP68 HE	103
CT-SG2 TP	109
CT-SG3 IP68 HE	103
CT-SG3 TP	109
CT-SG4 IP68 HE	103
CT-SG4 TP	109
CT-S/GOF	55
CT-S/GOF-030-FSMA	55
CT-S/GOF-100-SC	55
CT-S/GOF-100-ST	55
CT-S-LCT06	73
CT-SM1	91
CT-SM1-PC	91
CT-SM2	91
CT-SM2-PC	91
CT-SM2/PW	91
CT-SM2/SSL	99
CT-SM2/ZV	104

Type	Page
CT-SM3	91
CT-SM3-PC	91
CT-SM3/PW	91
CT-SM3/SSL	99
CT-SM3/ZV	104
CT-SM4	91
CT-SM4-PC	91
CT-SM4/PW	91
CT-SM4/SSL	99
CT-SM4/ZV	104
CT-SM5	91
CT-SM5-PC	91
CT-SM5/PW	91
CT-SM6	91
CT-SM6-PC	91
CT-SP0,6/0,14-0,25 AU	39
CT-SP1/0,25-0,75K AU	37
CT-SP1/0,25-0,75L AU	37
CT-SP1,5/0,5-1,5-HV	31
CT-SP1,5/0,5-1,5K AU	33, 59
CT-SP1,5/0,5-1,5L AU	33
CT-SP1,5/1,5K AU	33
CT-SP3/2,5-4K AU	25, 27
CT-SP3/2,5-4L AU	25, 27
CT-SP3/2,5-4/PE AU	27
CT-SP3/2,5-HV AU	29
CT-SP6/6 AG	23
CT-SP6/10 AG	23
CT-SP6/16 AG	23
CT-SP6/16/PE AG	21
CT-SP8/10 AG	19
CT-SP8/10 AU	19
CT-SP8/16 AG	19
CT-SP8/16 AU	19
CT-SP8/25 AG	19
CT-SP8/25 AU	19
CT-SP8/25/PE AG	21
CT-SP8/25/PE-L AG	15
CT-SP8/35 AG	19
CT-SP8/35/PE-L AG	15

Type	Page
CT-SP8/50/PE-L AG	15
CT-SP10/10/PE-GND AG	115
CT-SP10/16/PE-GND AG	115
CT-SP10/25/PE-GND AG	115
CT-SP10/35/PE-GND AG	115
CT-SP10/50/PE-GND AG	115
CT-SP10/AWG4/PE-GND AG	115
CT-SP12/50 IP2X AG	11
CT-SP12/70 IP2X AG	11
CT-SP12/95 IP2X AG	11
CT-S/POF	53
CT-S-RCT03/¼"	63
CT-S-RCT03/4	63
CT-S-RCT03/6	63
CT-S-RCT03/PLV 2/4	63
CT-S-RCT03/PLV4/6	63
CT-S-RCT06/8	67
CT-S-RCT06/PLV6/8	67
CT-S-RCT06/PLV8/10	67
CT-S-SCT03	69
CT-S-SCT05	71
CT-S-UCT04/¼"	63
CT-S-UCT04/6	63
CT-S-UCT06/8	65
CT-S-UCT08/3/8"	67
CT-S-UCT08/10	67
CT-TG1-G IP68 HE	102
CT-TG1-G TP	108
CT-TG1-S IP68 HE	102
CT-TG1-S TP	108
CT-TG2-G IP68 HE	102
CT-TG2-G TP	108
CT-TG2-S IP68 HE	102
CT-TG2-S TP	108
CT-TG3-G IP68 HE	102
CT-TG3-G TP	108
CT-TG3-S IP68 HE	102
CT-TG3-S TP	108
CT-TG4-G IP68 HE	102
CT-TG4-G TP	108

Type	Page
CT-TG4-S IP68 HE	102
CT-TG4-S TP	108
CT-ZV/B	104
DBP2-AL/0,14-0,5	59
DBP2-CO/0,14-0,5	59
DBP2-CR/0,14-0,5	59
DBP2-CU/0,14-0,5	59
DBP2-FE/0,14-0,5	59
DBP2-NICRSI/0,14-0,5	59
DBP2-NISI/0,14-0,5	59
DSP2-AL/0,14-0,5	59
DSP2-CO/0,14-0,5	59
DSP2-CR/0,14-0,5	59
DSP2-CU/0,14-0,5	59
DSP2-FE/0,14-0,5	59
DSP2-NICRSI/0,14-0,5	59
DSP2-NISI/0,14-0,5	59
F/M8 DIN6798A BN781	16
F/M10 DIN6798A BN781	12
K-SCH25-8	16
K-SCH35-6	19, 21
K-SCH35-8	16
K-SCH50-8	16
K-SCH50-10	12
K-SCH70-10	12
K-SCH95-10	12
LI-BL-SHR	78
LI-SHR-GF	78
MALU-PZ13	122
MBA-WZ1/1,2	125
MBA-WZ1,5	125
MBA-WZ3	125
MBA-WZ5	124
MBA-WZ6	125
MES-CZ	122
MES-CZ-CT0,6	122
MES-CZ-CT0,6-COAX-RG	122
MES-CZ-CT1	122
MES-CZ-CT1,5	122
MES-CZ-CT1,5-HV	122

Type	Page
MES-CZ-CT3	122
MES-PZ-TB5/6	122
MES-PZ-TB8/10	122
MES-PZ-TB9/16	122
MES-PZ-TB11/25	122
ME-WZ1,5/2	124
ME-WZ3	124
ME-WZ5	124
ME-WZ6	124
MPS-PZ13	122
M-PZ13	122
M-PZ-T2600	122
MSA-WZ1/1,2	125
MSA-WZ1,5	125
MSA-WZ4	125
MSA-WZ5	124, 125
MSA-WZ6	124, 125
MSA-WZ8	125

Type	Page
MU0,8D/M8 AG	16
MVS1	33, 59
MVS3	25, 27
MVS5	23
TB7-20	122
TB8-17	122
TB9-13	122
TB11-14,5	122
U/M8 AG	16
U/M10 AG	12
ZYL-SHR-IN-6KT M10×20 ISO4762 BN610	12



● Stäubli Units ○ Representatives/Agents

Global presence of the Stäubli Group

www.staubli.com