

Type 1

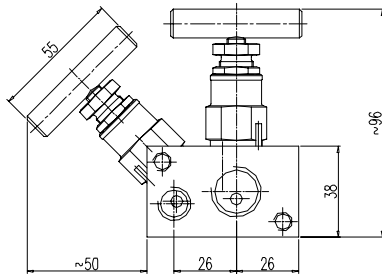

Type 2

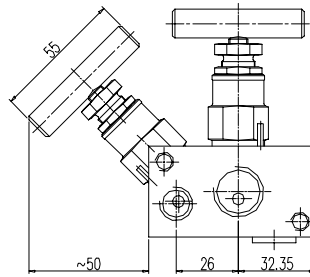

The EDM series manifolds allow direct mounting to a baseplate or a backplate of the enclosures.

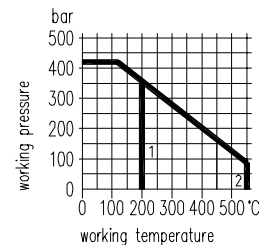
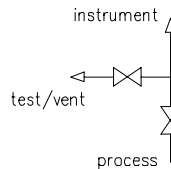
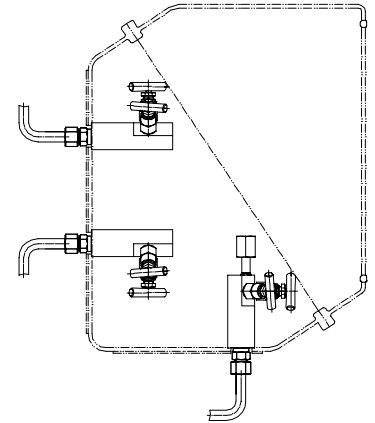
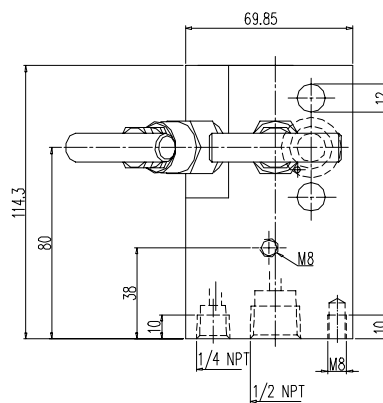
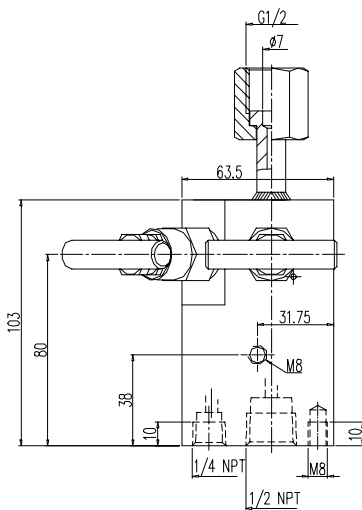

1 PTFE packing
 2 graphite packing

MOUNTING ACCESSORIES see section 8 and 10

Type	Material	Connections		Test / Vent	Part no.
		Inlet	Outlet		
1	st. st.	1/2 NPT female	swivel nut G 1/2	1/4 NPT female	N342.44.472.11
2	st. st.	1/2 NPT female	DIN EN 61518, Type A ⁴⁾		N542.44.472.01

Components	Stainless steel ¹⁾
	DIN - Material Number
Body ²⁾	1.4404 / 316L
Bonnet	1.4401 / 316
Valve stem	1.4404
Needle tip ³⁾	1.4571
Packing	PTFE up to 200°C (graphite up to 550°C)
Gland nut	1.4301
T-handle	stainless steel

- External stem thread
- Stem with cold rolled surface, back seat and non-rotating needle tip
- Special types are available
- The manifolds can be supplied according to NACE-standard

- 1) Can also be supplied for oxygen service. Please notice order instruction B 3!
- 2) Available with inspection certificate 3.1 acc. to EN 10 204
- 3) Also available with soft tip in KEL-F® (PCTFE) or POM
- 4) Dimensions acc. to DIN EN 61518 see order instruction B 4