

FANUC AC SPINDLE SERVO UNIT
S series/P series

MAINTENANCE MANUAL

B-65015E/03

©FANUC LTD, 1987



This manual describes following models.

Series name	Model name
AC SPINDLE SERVO UNIT S series	Model 1S, Model 1.5S, Model 2S, Model 3S, Model 6S, Model 8S, Model 12S, Model 15S, Model 18S, Model 22S, Model 26S
AC SPINDLE SERVO UNIT P series	Model 8P, Model 12P, Model 15P, Model 18P, Model 22P, Model 30P, Model 40P, Model 50P, Model 60P

6-NOV-95
RE: FANUC SPINDLE DRIVES.
TO REINITIALIZE

N.V. RAIN:

- 1) SET SWITCH TO TEST.
- 2) PWR UP.
- 3) HOLD DOWN ALL 4 BUTTONS
- 4) MODE TO FC22
- 5) HOLD "DATA SET" UNTIL
DRIVE DISPLAY READS
GOOD.
- 6) TURN OFF POWER
- 7) SET JUMPER BACK TO
"DRIVE"
- 8) PWR UP, CHECK REAMBER

In this manual we have tried as much as possible to describe all the various matters.

However, we cannot describe all the matters which must not be done, or which cannot be done, because there are so many possibilities.

Therefore, matters which are not especially described as possible in this manual should be regarded as "impossible".

TABLE OF CONTENTS

I. AC SPINDLE SERVO UNIT S SERIES	
1. GENERAL	3
1.1 Configurations	3
1.1.1 Models 1S - 3S	3
1.1.2 Models 6S - 26S	4
1.2 Major Components	5
2. DAILY MAINTENANCE AND MAINTENANCE TOOLS	10
2.1 AC Spindle Motor	10
2.2 AC Spindle Servo Unit	10
2.3 Maintenance Tools	10
2.4 Major Maintenance Parts	10
3. INSTALLATION	11
3.1 Installation Procedure	11
3.2 Power Connection	12
3.2.1 Power voltage and capacity check	12
3.2.2 Protective earth connection	12
3.2.3 Power connection	12
3.3 AC Spindle Motor Connection	12
3.4 Single Cable Connection	12
4. TROUBLESHOOTING	13
4.1 Power Voltage Check	13
4.2 Power On Indicator Lamp P.I.L. is not Lit	14
4.3 Alarm is Indicated	15
4.4 Motor does not Rotate or its Rotation is Abnormal	24
4.5 Vibrations or Noises are too Large during Rotation	25
4.6 Noise is Produced from Motor during Deceleration (models 6S - 26S)	25
4.7 Speed Overshooting or Hunting Occurs	25
4.8 Cutting Force is Low	26
4.9 Orientation is not Correct	26
4.10 Acceleration/Deceleration Time is Long	27
5. SETTING AND ADJUSTING	28
5.1 Models 1S - 3S	28
5.1.1 Setting pin	28
5.1.2 Variable resistor	29
5.2 Models 6S - 26S	30
5.3 Parameter Setting Method	31
5.4 Number and Contents of Parameter	32
5.5 Setting Rank	45
5.5.1 Models 1S - 3S	45
5.5.2 Models 6S - 26S	46
5.6 Setting and Adjusting Spindle Orientation Control Circuit	46
6. REPLACING FUSE AND PCB	47
6.1 Replacing Fuse	47
6.2 Replacing PCB	47
6.3 Replacing Option (orientation, spindle switching, speed range switching) PCB	47
6.4 Replacing Transistor Module	48

7.	SPINDLE ORIENTATION CONTROL CIRCUIT	51
7.1	Configuration	51
7.2	Setting and Adjusting Spindle Orientation Control Circuit of Position Coder System	54
7.2.1	2-stage spindle speed change or less	54
7.2.2	When spindle 3, 4-stage speed change	59
7.3	Adjusting Spindle Orientation Control Circuit of Magnetic Sensor Type	65
7.3.1	Mounting magnetizing element and magnetic sensor	65
7.3.2	When spindle 2-stage speed change	66
7.3.3	When spindle less than 2-stage speed change/ high-speed spindle	73
7.3.4	When spindle 3-stage speed change	74
7.3.5	Checking method of spindle system position loop gain	77
8.	SPINDLE SWITCHING CONTROL CIRCUIT	79
8.1	Configuration	79
8.2	Adjusting Spindle Switching Control Circuit	80
9.	SPEED RANGE SWITCHING CONTROL CIRCUIT	83
9.1	Configuration	83
9.2	Adjusting Speed Range Switching Control Circuit	84
10.	SPEED GAIN SWITCHING CIRCUIT	87
10.1	Configuration	87
10.2	Adjusting Speed Gain Switching Circuit	88
11.	SIGNAL CONVERSION CIRCUIT	89
11.1	Configuration	89
11.2	Adjusting Signal Conversion Circuit	90

APPENDIX

APPENDIX 1	CONNECTION DIAGRAM	101
APPENDIX 2	CABLE ROUTING	110
APPENDIX 3	CABLE SPECIFICATIONS	113
APPENDIX 4	CONFIGURATION OF MAIN CIRCUIT	117
APPENDIX 5	LOCATION OF UNIT	118
APPENDIX 6	LOCATION OF PCB	122
APPENDIX 7	MAJOR PARTS	125
APPENDIX 8	ADJUSTING AND SETTING PCB	128
APPENDIX 9	CHECK TERMINAL LIST	130
APPENDIX 10	MAGNETIC SENSOR SIGNALS CHECKING METHOD	135
APPENDIX 11	PARAMETER LIST	138

1. GENERAL

This manual describes maintenance of AC spindle servo units S series and P series.

1.1 Configurations

1.1.1 Models 1S - 3S

Models 1S - 3S of AC spindle servo units consist of the following units.

- 1) Spindle control unit (basic)
- 2) Resistor unit (basic)
- 3) Spare fuse (basic)
- 4) Connector for connection (basic)
- 5) Spindle orientation control circuit (option)
- 6) AC line filter (option)
- 7) Power transformer (option)

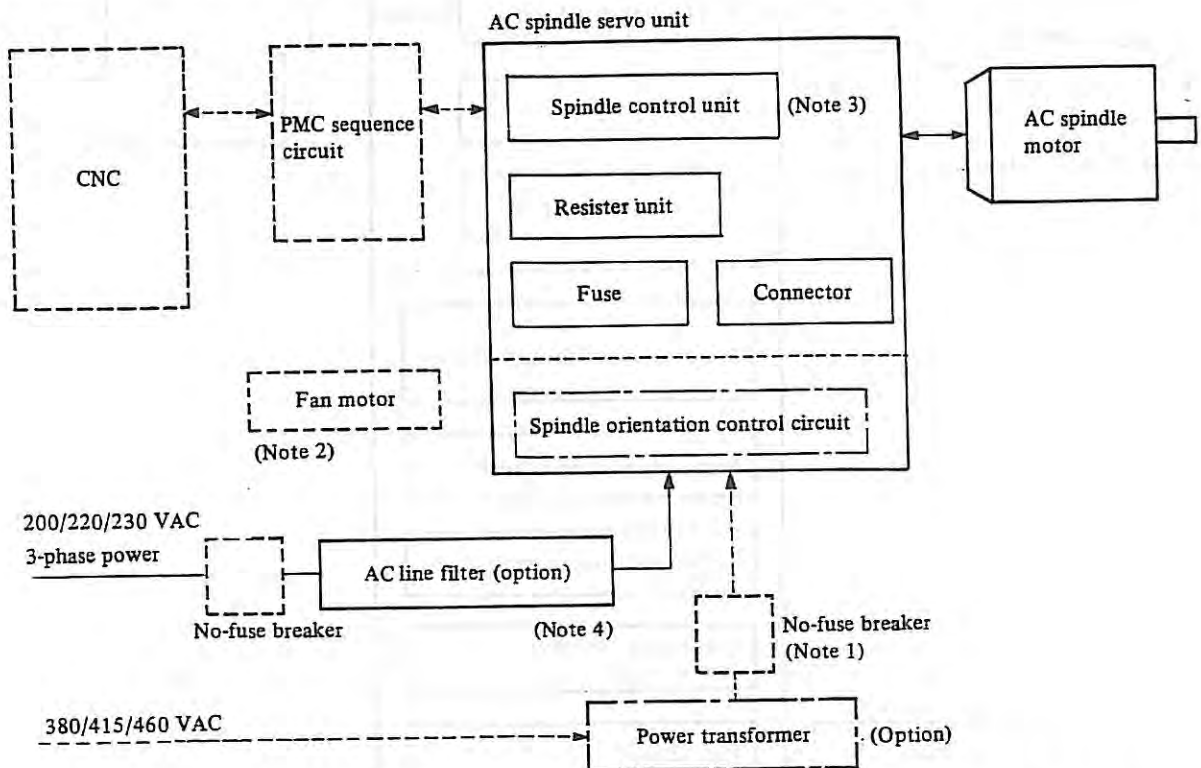

- Note 1) An overcurrent protector (no-fuse breaker, etc.) is provided by the MTB for the input circuit of AC spindle servo unit S series.
- Note 2) Cool the spindle control unit using a fan motor having a specific wind speed.
- Note 3) For the PCB configuration refer to Appendix 2.
- Note 4) When not using the power transformer, be certain to use the AC line filter.

1.1.2 Models 6S - 26S.

Models 6S - 26S of S series AC spindle servo units consist of the following units.

- 1) Spindle control unit (basic)
- 2) Spare fuse (basic)
- 3) Connector for connection (basic)
- 4) Spindle orientation control circuit (option)
- 5) Speed gain switching circuit (option)
- 6) Spindle switching control circuit (option)
- 7) Speed range switching control circuit (option)
- 8) Power transformer (option)
- 9) Unit adapter (option)

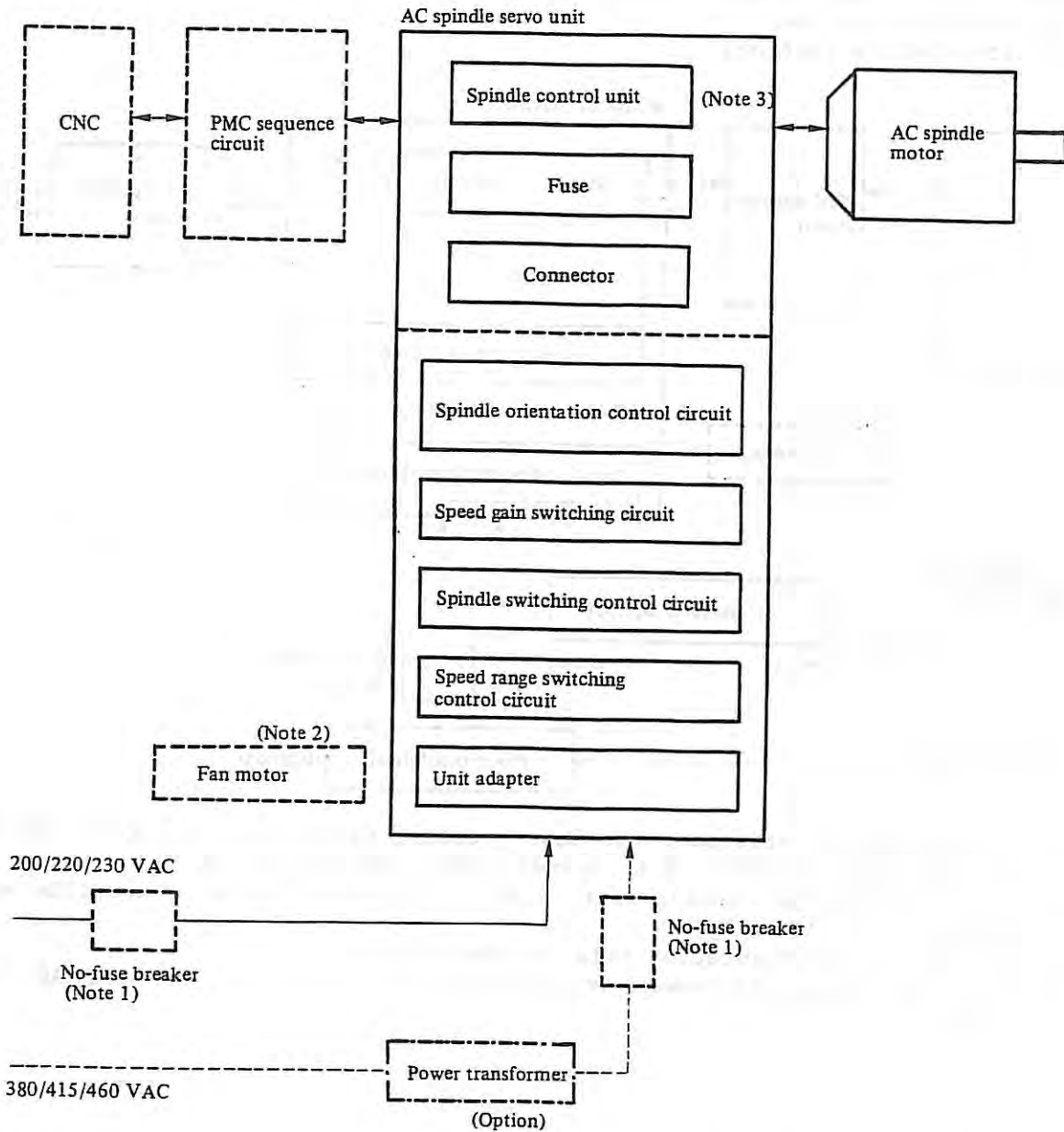

Note 1) An overcurrent protector (no-fuse breaker, etc.) is provided by the MTB for the input circuit of AC spindle servo unit S series.

Note 2) Cool the spindle control unit using a fan motor having a specific wind speed.

Note 3) For PCB configuration refer to Appendix 2.

1.2 Major Components

Table 1.2 (a) Major components (S series)

Model	Order specification	Unit	PCB	ROM		
				Specification	Type	
1S 8000rpm	A06B-6059-H002#H501	A06B-6059-H002	A16B-1100 -0200 (PCB1) + A16B-1100 -0240 (PCB2)	A06B-6059-H501	9801	
1.5S 8000rpm	A06B-6059-H002#H508	A06B-6059-H002		A06B-6059-H508	9808	
2S 8000rpm	A06B-6059-H002#H502	A06B-6059-H002		A06B-6059-H502	9802	
3S 6000rpm	A06B-6059-H003#H503	A06B-6059-H003		A06B-6059-H503	9803	
6S/A3 6000rpm	A06B-6059-H203#H523	A06B-6059-H203	A20B-1003 -0010 (PCB1) + A20B-1003 -0020 (PCB2)	A06B-6059-H523	9823	
6S 6000rpm	A06B-6059-H206#H511	A06B-6059-H206		A06B-6059-H511	9811	
8S 4500rpm	A06B-6059-H208#H512	A06B-6059-H208		A06B-6059-H512	9812	
8S 6000rpm	A06B-6059-H208#H513	A06B-6059-H208		A06B-6059-H513	9813	
12S/A8 4500rpm	A06B-6059-H208#H524	A06B-6059-H208		A06B-6059-H524	9824	
12S/A8 6000rpm	A06B-6059-H208#H525	A06B-6059-H208		A06B-6059-H525	9825	
12S 4500rpm	A06B-6059-H212#H514	A06B-6059-H212		A06B-6059-H514	9814	
12S 6000rpm	A06B-6059-H212#515	A06B-6059-H212		A06B-6059-H515	9815	
15S 4500rpm	A06B-6059-H215#H516	A06B-6059-H215		A20B-1003 -0010 (PCB1) + A20B-1003 -0120 (PCB2)	A06B-6059-H516	9816
15S 6000rpm	A06B-6059-H215#H517	A06B-6059-H215			A06B-6059-H517	9817
18S 4500rpm	A06B-6059-H218#H518	A06B-6059-H218	A06B-6059-H518		9818	
18S 6000rpm	A06B-6059-H218#H519	A06B-6059-H218	A06B-6059-H519		9819	

Model	Order specification	Unit	PCB	ROM	
				Specification	Type
22S 4500rpm	A06B-6059-H222#H520	A06B-6059-H222		A06B-6059-H520	9820
22S 6000rpm	A06B-6059-H222#H521	A06B-6059-H222		A06B-6059-H521	9821

Table 1.2 (b) Configuration elements (P series 1:8)

Model	Order specification	Unit	PCB	ROM	
				Specification	Type
8P 6000rpm	A06B-6059-H206#H550	A06B-6059-H206	A20B-1003 -0010 (PCB1) + A20B-1003 -0020 (PCB2)	A06B-6059-H550	9850
12P 6000rpm	A06B-6059-H206#H551	A06B-6059-H206		A06B-6059-H551	9851
15P 6000rpm	A06B-6059-H208#H552	A06B-6059-H208		A06B-6059-H552	9852
18P 6000rpm	A06B-6059-H212#H553	A06B-6059-H212		A06B-6059-H553	9853
22P 6000rpm	A06B-6059-H215#H582	A06B-6059-H215		A20B-1003 -0010 (PCB1)	A06B-6059-H582
30P 4500rpm	A06B-6059-H218#H555	A06B-6059-H218	+ A20B-1003 -0120 (PCB2)	A06B-6059-H518	9855
40P 4500rpm	A06B-6059-H222#H579	A06B-6059-H222		A06B-6059-H579	9879

Table 1.2 (c) Configuration elements (P series 1:12)

Model	Order specification	Unit	PCB	ROM	
				Specification	Type
15P 6000rpm	A06B-6059-H208#H565	A06B-6059-H208	A20B-1003 -0010 (PCB1) +	A06B-6059-H565	9865
18P 6000rpm	A06B-6059-H212#H563	A06B-6059-H212		A20B-1003 -0020 (PCB2)	A06B-6059-H563
22P 6000rpm	A06B-6059-H215#H554	A06B-6059-H215	A20B-1003 -0010 (PCB1) +	A06B-6059-H554	9854
40P 4800rpm	A06B-6059-H222#H556	A06B-6059-H222		A20B-1003 -0120 (PCB2)	A06B-6059-H556
40P 6000rpm	A06B-6059-H222#H577	A06B-6059-H222		A06B-6059-H577	9877
50P 4500rpm	A06B-6059-H218#H605	A06B-6059-H218		A06B-6059-H605 (Speed range switching type)	9B05
60P 4500rpm	A06B-6059-H222#H605	A06B-6059-H222		A06B-6059-H605 (Speed range switching type)	9B05

Table 1.2 (d) Configuration elements (Orientation circuit)

Name	Order specifications	PCB	Application unit
Orientation ARII (Position coder, 2-stage speed change)	A06B-6059-J110	A20B-0008-0242	Models 1S - 3S
Orientation BRII (Position coder, 2-stage speed change)	A06B-6059-J111	A20B-0008-0243	
Orientation CR (Magnetic sensor, 2-stage speed change)	A06B-6059-J120	A16B-1300-0110	
Orientation GR (Magnetic sensor, 2-stage speed change)	A06B-6059-J121	A20B-1300-0111	

Name	Order specifications	PCB	Application unit
Orientation ASII (Position coder, 2-stage speed change)	A06B-6059-J130	A20B-0008-0242	Models 6S - 26S
Orientation BSII (Position coder, 2-stage speed change)	A06B-6059-J131	A20B-0008-0243	
Orientation AHS (Position sensor, 2-stage speed change)	A06B-6059-J132	A20B-0008-0244	
Orientation BHS (Position coder, 2-stage speed change)	A06B-6059-J133	A20B-0008-0245	
Orientation ES (Position coder, 4-stage speed change)	A06B-6059-J134	A20B-1000-0462	
Orientation FS (Position coder, 4-stage speed change)	A06B-6059-J135	A20B-1000-0463	
Orientation CSII (Magnetic sensor, 2-stage speed change)	A06B-6059-J140	A20B-0008-0032	
Orientation DSII (Magnetic sensor, 2-stage speed change)	A06B-6059-J142	A20B-0009-0521	
Orientation GSII (Magnetic sensor, 2-stage speed change)	A06B-6059-J141	A20B-0008-0033	

Table 1.2 (e) Configuration elements (Speed gain switching circuit)

Name	Order specifications	PCB	Application unit
Speed gain switching circuit	A06B-6059-J700	A16B-1700-0021	Models 6S - 26S

Table 1.2 (f) Configuration elements (Spindle switching control circuit)

Name	Order specifications	PCB	Application unit
Spindle switching control circuit (Without orientation signal switching)	A06B-6059-J701	A20B-1000-0654	Models 6S - 26S
Spindle switching control circuit (With orientation signal switching)	A06B-6059-J702	A20B-1000-0655	

Table 1.2 (g) Configuration elements (Speed range switching control circuit)

Name	Order specifications	PCB	Application unit
Speed range switching control circuit	A06B-6059-J703	A20B-1000-0653	Models 6S - 26S

2. DAILY MAINTENANCE AND MAINTENANCE TOOLS

Check and clean the following items once every 6 months or so for using the AC spindle motor and AC spindle servo units under a normal condition for a long time.

Take the check frequency into consideration according to the contamination degrees in each item.

2.1 AC Spindle Motor

If the ventilation hole, cooling fan, and fan finger guard (net) of the AC spindle motor become dusty, the radiation efficiency of the motor drops. Clean the AC spindle motor by using the factory air and a vacuum cleaner.

2.2 AC Spindle Servo Unit

If the cooling fan which compulsorily cools the radiator section of the AC spindle servo unit and the fan supplied with the unit adapter are used for a long period, the radiator section or regenerative resistor may become dusty. In these cases the cooling efficiency of the unit is lowered.

In the same manner as for the motor, clean the fan motor section and radiator section.

2.3 Maintenance Tools

Use tools indicated in Table 2.3 (a) for adjustments and tools indicated in Table 2.3 (b) for repairing troubles.

Table 2.3 (a) Tools used for adjustments

Name	Specification	Use
AC voltmeter	1 - 300 V $\pm 1\%$ or less	AC power voltage measurement
\oplus , \ominus screwdrivers	\oplus large, medium size \ominus large, medium, small size	

Table 2.3 (b) Tools used for repairing troubles

Name	Specification	Use
AC voltmeter	1 - 300 V $\pm 1\%$ or less	AC power voltage measurement
DC voltmeter	1 mV - 500 V $\pm 1\%$ or less	DC power voltage measurement and offset voltage check
Circuit tester		Resistance value check
\oplus , \ominus screwdrivers	\oplus large, medium size \ominus large, medium, small size	

2.4 Major Maintenance Parts

For maintenance parts, see appendix 7 Major maintenance parts.

3. INSTALLATION

3.1 Installation Procedure

Observe the checking procedure shown in Table 3.1 at the installation.

Table 3.1 Installation procedures

Item	Description	Remarks
1	Check if specifications of motor, servo unit, options, etc. are correct.	Check if motor corresponds to units, PCB, and ROM correctly according to Table 1.2 (a) - (c).
2	Check appearance for damage	In particular, check that there are no scratches or damage to the parts on the PCB.
3	Check the working power supply for voltage, voltage fluctuation, power capacity (kVA) and frequency.	Refer to Table 3.2.1 (b).
4	Connect the earth wire, power cable and drive power cable.	Refer to sections 3.2, 3.3, 3.4 and Appendix 1.
5	Turn on power supply, and make sure that green lamp P1L lights on PCB.	Refer to Appendix 6.
6	Check setting and adjustment results.	Refer to section 5.
7	Give rotation command to check the normal rotation and reverse rotation movement.	
8	Check the operation over the entire velocity range.	
9	Adjust spindle orientation circuit.	Refer to section 7.

3.2 Power Connection

3.2.1 Power voltage and capacity check

Measure the AC power voltage before connecting the power supply, and take the following measure according to power voltage.

Table 2.2.1 (a) Checking power voltage

AC power voltage	Nominal voltage	Measures
170 - 253 VAC	200/220/230 V	Connect directly.
Higher than 254 VAC	380 V to 550 V	Set input voltage to 200 VAC using insulation transformer.

The input power specification of the AC spindle servo unit is as specified in Table 3.2.1 (b). Use a power source having the power capacity having a sufficient allowance so that no trouble due to voltage drop occurs with the maximum load.

Table 3.2.1 (b) Input power specification

Nominal rated voltage	200/220/230 VAC, 3 phases											
Allowable voltage fluctuation	-15% to +10%											
Frequency	50 Hz/60Hz \pm 1 Hz.											
Capacity with 30-minute rating	Model	1S	1.5S	2S	3S 6S/A3	6S	8S 12S/A8	12S	15S	18S	22S	26S
	kVA	4	7	7	9	12	17	22	26	32	37	45
	Model	8P	12P	15P	18P	22P	30P	40P	50P	60P		
	kVA	9	12	15	17	22	26	32	44	44		

3.2.2 Protective earth connection

Connect the protective earth to connection terminal G before connecting the power supply. Use the protective earth having sufficient capacity as compared with the feeder circuit breaker capacity.

3.2.3 Power connection

Connect the power cable after protective earth connection.

The power phase rotation is not specified for AC spindle servo unit.

The cooling fan motor employs three-phase power. When connect the input power to the unit, check the proper phase connection.

3.3 AC Spindle Motor Connection

Connect the AC spindle motor according to the connection diagram in Appendix 1. If the drive power cable connection sequence is in error, vibration are produced the motor does not rotate or alarm (AL-02) occurs to stop the motor. Always connect protective earth "G".

3.4 Signal Cable Connection

Connect the signal cable according to the connection diagram in Appendix 1.

4. TROUBLESHOOTING

Perform troubleshooting, referring to each item in Table 4 according to trouble conditions if a trouble occurred.

Table 4 Types of trouble conditions

Item	Trouble conditions	Reference item
1	Power voltage check	4.1
2	Power ON indicator lamp P1L does not light.	4.2
3	Alarm (AL-□□) is displayed on the PCB.	4.3
4	Motor does not rotate. Number of rotation is not as specified.	4.4
5	Vibrations and noises are noticeable during rotation.	4.5
6	An abnormal noise is produced from motor during deceleration.	4.6
7	Motor speed overshoots or hunting occurs.	4.7
8	Cutting power drop	4.8
9	Spindle orientation is not correct.	4.9
10	Acceleration/deceleration time is longer than specified.	4.10

Regarding the spindle switching circuit and speed range switching circuit, refer to chapters 8 and 9 respectively.

Note) When replacing the PCB, follow the cautions described in section 6.2. Refer to Appendix 2.

4.1 Power Voltage Check

Check power voltage and control power voltage on the spindle control PCB. Test points and standard values are as specified in Table 4.1.

Table 4.1 Power voltage check

Power voltage check	Check at INPUT terminals R,S,T,G (See 3.2)		
Control power voltage check on the PCB	Voltage	Test points	Standard value
	+24 V	+24 V - 0 V	About 23 V <u>+4%</u>
	+15 V	+15 V - 0 V	+15 V <u>+4%</u>
	+5 V	+5 V - 0 V	+5 V <u>+2%</u>
	-15 V	-15 V - 0 V	-15 V <u>+4%</u>

Test points (refer to Appendix 6.)

According to the PCB version number, there are cases when the shaded section is a connector, and cases when it is a check terminal. In both cases, exercise sufficient caution because a voltage of 200 VAC is applied when 1S - 3S, and 300 VDC when 6S - 26S.

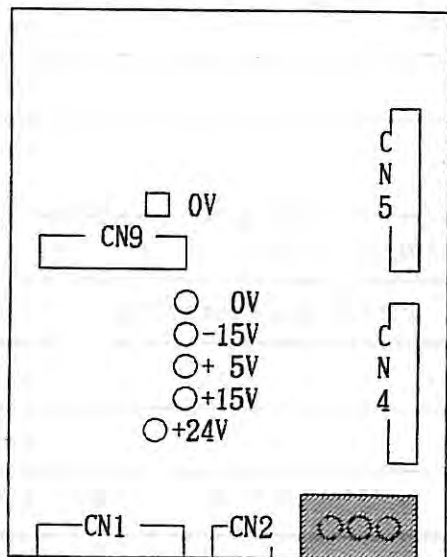

Spindle control PCB for models 1S - 3S
A16B-1100-0200 (Model 1S - 3S)

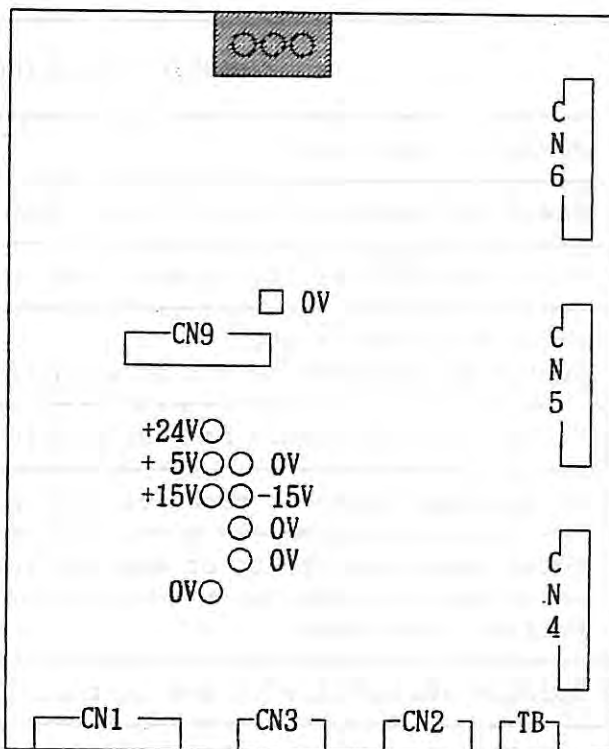

Spindle control PCB for models 6S - 22S
A20B-1003-0010 (Model 6S - 26S)

4.2 Power on Indicator Lamp PIL is not Lit

Table 4.2 Check procedure remedy

Item	Causes	Check procedure	Remedy
1	Power is not supplied.	Check it at power input terminals R,S,T.	
2	For models 6S - 26S, fuse FUR, FUS or FUT is blown.	Check presence/absence of blown fuse. (Appendix 5 Refer to parts arrangement diagram)	<ul style="list-style-type: none"> • Replace fuse. • Check presence/absence of coil short circuit of fan motor.
3	For models 1S - 3S, fuse F1 or F2 is blown.	Check if fuse is blown, or check if alarm indication of fuse appears.	<ul style="list-style-type: none"> • Check presence/absence of short circuit of speed feedback signal, and short circuit of orientation position coder signal. • Replace fuse. • Replace PCB when fuse is blown even if replacing it.
	For models 6S - 26S, fuse F2 or F3 is blown. (Note 1)		
	For models 6S - 26S, fuse F3 is blown. (Note 2)		

Item	Causes	Check procedure	Remedy
4	PCB connectors are not plugged correctly. CN4, 5 : models 1S-3S CN4 - 6: models 6S-26S	Check if the connector guide groove appears on the PCB connector surface.	Refer to section 6.
5	PCB power circuit is defective.	Check power voltage according to Table 4.1.	Replace PCB. Refer to section 6.

Note 1) PCB version number 09A and earlier

Note 2) PCB version number 10B and later

(Checking method of PCB version number)

A20B-1003-0010/□□□
 PCB diagram number ↑
 3-digit alphanumeric stamp

The 3-digit alphanumeric stamp after the diagram number display on the PCB is the version number of that PCB.

4.3 Alarm is Indicated

Alarms on AC spindle motor and servo unit are indicated on five digits of seven-segment on the servo unit PCB. Correspondence between seven-segment indications and alarm signals is shown in Table 4.3 (a), (b).

Table 4.3 (a) Alarm (models 1S - 3S)

Alarm No.	Meanings	Contents	Remedy
AL-01	Motor unit overheat	This lamp lights when internal temperature of motor is higher than the specified value.	Cool the motor unit and reset the alarm.
AL-02	Excessive deviation of speed	This lamp lights when the motor speed is largely deviated from the command speed.	Reset alarm.
AL-03	Defective regenerative current	Detects that regenerative current has flown longer than the allowable time.	Reset alarm after removing the problem.
AL-04		—	
AL-05		—	
AL-06	Overspeed (Analog detection)	This lamp lights when the motor exceeds 115% of the rated speed.	Reset alarm.

Alarm No.	Meanings	Contents	Remedy
AL-07	Overspeed (Digital detection)	This lamp lights when the motor exceeds 115% of the rated speed.	Reset alarm.
AL-08	Overvoltage	This lamp lights when voltage largely exceeds the rated working voltage range due to a tap selection failure, etc.	Reset alarm.
AL-09	—		
AL-10	Detects lower voltage.	Detects the input power voltage lessened.	Remove the problem and reset the alarm.
AL-11	Excessive high voltage of DC link	Detects over DC voltage of power.	Remove the problem and reset the alarm.
AL-12	Abnormal current of DC link Defective transistor	Detects over current of circuit.	Remove the problem and reset the alarm.
AL-13 - 15	—		
AL-16 - 23	Defective arithmetic circuit and peripheral circuit		
No indication	Defective ROM		

Table 4.3 (b) Alarm details of models 6S - 26S

Alarm No.	Meanings	Contents	Remedy
AL-01	Motor overheat	This lamp lights when internal temperature of motor is higher than the specified value.	Cool the motor and reset the alarm.
AL-02	Excessive deviation of speed	This lamp lights when the motor speed is largely deviated from the command speed.	Reset alarm.
AL-03 (Note 1)	+24 V fuse is blown. (before PCB edition 09A)	+24 V fuse of the control power is blown.	Replace a fuse and turn on the power again.

Alarm No.	Meanings	Contents	Remedy
AL-04	Open phase of input power	A phase of 3-phase input power is open.	Remove the problem and reset alarm.
AL-05	—		
AL-06	Overspeed (Analog detection)	This lamp lights when the motor exceeds 115% of the rated speed.	Reset alarm.
AL-07	Overspeed (Digital detection)	This lamp lights when the motor exceeds 115% of the rated speed.	Reset alarm.
AL-08	Overvoltage	Voltage extremely exceeds the rated voltage.	Reset alarm.
AL-09	Overheat of radiator	Temperature of radiator such as semiconductor is extremely high.	Cool the unit and reset an alarm.
AL-10	Lower voltage of input power	Detects lower voltage of input power.	Remove the problem and turn on the power again.
AL-11	Excessive high voltage of DC link	Detects over DC voltage of power.	Remove the problem and reset the alarm.
AL-12	Abnormal current of DC link Defective transistor	Detects over current of circuit.	Remove the problem and reset the alarm.
AL-13	Defective arithmetic circuit	Abnormal transmission between CPU and peripherals	Remove the problem and reset the alarm.
AL-14	Defective ROM	Detects defective ROM.	Replace ROM.
AL-15 (Note 2)	Defective optional circuit	Detects defective optional circuit and erroneous connection to optional circuit.	Remove the problem and reset the alarm.
AL-16 - 23	Defective arithmetic circuit and peripheral circuit.		
No indication	Defective ROM		

Note 1) Not displayed in PCB version number 10B and later.

Note 2) Regarding details, refer to chapters 8 and 9.

(Method of alarm reset)

Normally, alarm reset is performed by the external contact signal, but the method to reset the alarm display on the PCB after removing the cause of the failure is described here.

- (1) Set OFF the rotation direction command (SFR, SRV).
- (2) Set OFF the orientation command (ORCM).
- (3) Set speed command voltage (VCMD) to 0 V.
- (4) For safety, set to the emergency stop (ESP) state.
- (5) While checking (1) - (4), if the setting switches "MODE" and "DATA SET" are simultaneously set ON, the alarm will be reset. (Regarding the installation position, refer to Appendix 6.)

1) (AL-01) Motor unit is overheated.

Item	Causes	Check	Remedy
1	Built-in fan motor of spindle motor is defective.		Replace fan motor.
2	Fan motor for unit cooling is defective		Replace fan motor.
3	Overload operation	Check it using a load meter.	Re-examine cutting conditions and tools.
4	Motor cooling system is dirty.		Remove dust. (Refer to section 2).
5	Disconnection or poor contact of wiring	Check connections between motor and servo unit.	Confirm the connection of the speed feedback cable connector (Note)

Note) Refer to Appendix 2.

2) (AL-02) Speed is deviated from the command value.

Item	Causes	Check	Remedy
1	Overload	Check it using a load meter.	Re-examine cutting conditions and tools.
2	Transistor module is defective.	Transistor collector-emitter is open.	Replace transistor module. (Note 1)
3	Blow out or poor connection of the driver protective fuse on PCB.	Check fuses F4A - F4M for blown out or missing.	Connect fuses securely, and replace blown out fuses, if any.

Item	Causes	Check	Remedy
4	Speed feedback signal is defective.	Check the speed feedback signal waveform. (Note 2)	Check the operation of the speed detector inside the motor, and check the connection and contact of speed feedback cable.
5	Wiring failure (disconnection, poor contact, etc.)	Check the connection between unit and motor.	Check the connection of the motor power line.

Note 1) Refer to section 6.4.

Note 2) Speed feedback signal check

Observe the speed feedback signal using an oscilloscope under the rotation command off (motor stop, drive power off) condition after turning on the power supply. Observe it at the following check terminals, while slowly turning the motor by hand.

Test points	Normal waveforms
PA-OV PB-OV	<p>PA PB</p> <p>$V_{P-P}=0.36\sim 0.5V$</p> <p>About 2.5V</p> <p>0V</p>
RA-OV RB-OV	2.5 \pm 0.2 VDC
PAP-OV PBP-OV (CCW rotation)	<p>PAP ON OFF</p> <p>OV</p> <p>PBP ON OFF</p> <p>OV</p> <p>0.4V</p> <p>4.5V</p> <p>Check within ON/OFF duty is 50%.</p> <p>(PAP and PBP signals are inverted in CW direction.)</p>

- 3) (AL-03) Defective regenerative circuit (Models 1S - 3S)
 +24 fuse is blown (Models 6S - 26S) (Note 1)
 - Models 1S - 3S: Defective regenerative circuit

Item	Causes	Check	Remedy
1	Transistor TR1 on the regenerative circuit is defective.	Check collector (C), emitter (E) and base (B) of transistor.	Replace transistor TR1.

- Models 6S - 26S: +24 fuse is blown. (Note 1)

Item	Causes	Check	Remedy
1	Fuse F1 on PCB is blown.		Replace fuse F1.

Note 1) Applies to PCB version number 09A and earlier. This alarm is not in version 10B and later.

Note 2) Refer to item 6.4.

- 4) (AL-04) Open phase of input power (models 6S - 26S)

Item	Causes	Check	Remedy
1	High impedance on power supply side. (Example) Two transformers are connected in series or when a variable auto-transformer is connected.	- Alarm lights only when the motor speed is reduced from high speed.	- Replace the power supply having low power impedance. (Note 1) - Looseness of input cable connector. Example: Open phase due to loosened screws.
2	Transistor module is defective.		Replace transistor module. (Note 2)
3	MCC or AC reactor is defective. Detection resistor R5 or R6 is open.		Replace the defective part.

Note 1) Power impedance checking method.

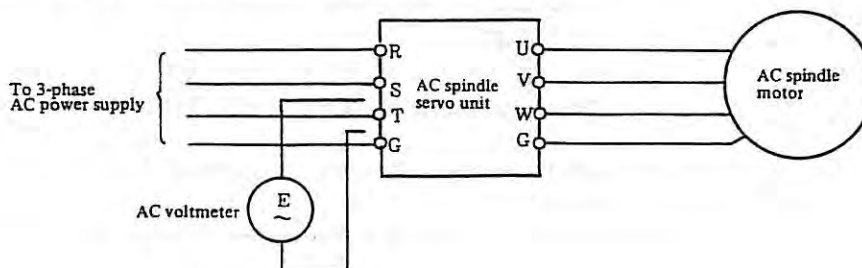

Calculation formula

$$\frac{E0 - E1}{E0} \times 100 (\%) < 7 (\%)$$

where E0: Voltage when the motor stops operating.

E1: Voltage during acceleration of motor or voltage just before the motor speed begins lowering with a load applied.

Input power specifications

Name	Specifications
Nominal rated voltage	200/220/230 VAC
Allowable voltage fluctuation width	-15% - +10%
Power frequency	50/60 Hz
Power impedance	Voltage fluctuation due to load (120% load at 30 minute rating): Less than 7%

Note 2) Refer to section 6.4.

5) (AL-06) Overspeed (analog detection)

Item	Causes	Check	Remedy
1	PCB setting failure or adjusting failure	Check PCB for normal setting and adjustment.	Change setting of PCB. Re-adjustment. Confirm parameter F-5.
2	Wrong specification of ROM	Check specification referring to Table 1.2.	Replace ROM.
3	Speed feedback signal waveform is defective.	Refer to item (2) AL-02. Check that there is no noise in the signal.	
4	PCB is defective.		Replace PCB. Refer to section 6. (Note)

Note) Refer to section 6.2.

6) (AL-07) Overspeed (digital detection)

Same as in (AL-06).

7) (AL-08) Overvoltage

Item	Causes	Check	Remedy
1	Power voltage exceeds the rated value.	Check power voltage.	Stabilize the input voltage.
2	Tap switching mistake of transformer, etc.		Wiring alteration.

8) (AL-09) Radiator is overheated. (models 6S - 26S).
Same as in (AL-01).

9) (AL-10) Input power voltage drops.

Item	Causes	Check	Remedy
1	When the power voltage becomes less than the rated value (-15%).	Check power voltage.	Stabilize the input voltage.

10) (AL-11) Overvoltage of DC link circuit.
(Regenerative circuit is faulty ... Regeneration failure)

Item	Causes	Check	Remedy
1	High power impedance.	Refer to "4) (AL-04)".	
2	PCB is defective.		Replace PCB. (Note)
3	Defective regenerative transistor module.		Replace transistor module. (Note)
4	Regenerative resistor is defective.		Replace pertinent part.

Note 1) Refer to section 6.2.

Note 2) Refer to section 6.4.

11) (AL-12) Overcurrent flows to DC link circuit.

Item	Causes	Check	Remedy
1	Output terminals or internal circuit of motor is shorted.	Check connections.	
2	Transistor module is defective.	Check the resistance between the collector emitter bases of the transistor by the tester. (Note)	Replace transistor module. (Note)
3	PCB is defective.		Replace PCB. (Note)

Note 1) Refer to section 6.2.

Note 2) Refer to section 6.3.

12) (AL-13) CPU alarm. (models 6S - 26S)
 Replace PCB. Refer to section 6.2.

13) (AL-14) ROM is defective. (models 6S - 26S)

Item	Causes	Check	Remedy
1	ROM is not mounted at all or not properly mounted.	Check if ROM is unplugged from the socket or if its leads are broken.	Mount ROM properly.
2	ROM is defective.	Check series No. of ROM.	Replace ROM. (Note)
3	Ratings of ROM are different.	Check series No. of ROM.	Replace ROM. (Note)

Note) Refer to Table 1.2 (a) - (c).

14) (AL-15) Defective optional circuit (models 6S - 22S).

Item	Causes	Check	Remedy
1	Spindle switching circuit/speed range switching circuit is defective.		Replace PCB. (Note 1)
2	Connection with spindle switching circuit/speed range switching circuit is defective.		Check and correct the connection. (Note 2)

Regarding the spindle switching circuit/speed range switching circuit, refer to chapters 8 and 9.

Note 1) Refer to section 6.3.

Note 2) Refer to Appendix 1.

4.4 Motor does not Rotate or its Rotation is Abnormal

Item	Causes	Check procedure	Remedy
1	Defective connection of motor power line	AL-02 occurs when rotation command is given. When AL-02 does not occur, make the speed command voltage large.	Check phase sequence, etc. connection. (Refer to Appendix 2.)
2	Speed feedback signal is defective.	Check signal cable connection. Check signal waveform. Refer to section 4.3(2) AL-02.	Check operation of speed detector inside motor, and check connection and contact of speed feedback cable.
3	Parameter is not proper.	Check whether or not the electromagnetic contactor is ON. Check use/non-use of override.	Set parameters F-01 and F-02 correctly. Refer to section 5.4.
4	ROM is not proper.	Check series No. of ROM. See Table 1.2 (a) - (c).	Set ROM correctly.

(Checking method of ROM series)

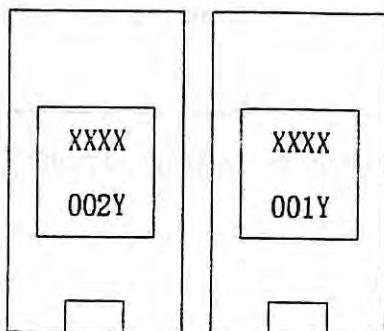

Series

XXXX ROM arrangement diagram number

98XX: A06B-6059-H5XX

9BXX: A06B-6059-H6XX

9CXX: A06B-6059-H7XX

Y : Version number
(A-Z, except however, for I, 0)

4.5 Vibration or Noises are too Large during Rotation

Item	Causes	Check procedure	Remedy
1	Motor is defective.		Replace motor.
2	Speed feedback signal is defective.	Check signal cable connection. Check signal waveform. Refer to section 4.3(2) AL-02.	Check operation of speed detector inside motor, and check connection and contact of speed feedback cable.
3	PCB is defective.	(Note 2)	Replace PCB. (Note 1)

Note 1) Refer to chapter 6.

Note 2) Method to run the motor idly and determine the cause of failure.

Regarding rotating the motor, if the speed feedback signal connector CN2 connected to the AC spindle servo unit is pulled out, AL01 occurs, and the motor runs idly.

(When made to run idly, check that the brakes are not applied by the sequence.)

During idle run, if vibrations and noises become extremely small as compared with the normal rotation, the control circuit is considered to be defective. In this case, the remedy is to replace the PCB.

Further, when the noise does not change, consider that there is a regenerative source on the motor and machine tool side.

4.6 Noise is Produced from Motor during Deceleration (models 6S - 26S)

During deceleration of the motor, energy is regenerated to the power supply through the regenerative control circuit. If the regenerative energy is excessive, the regenerative current limit circuit operates to change the motor current waveform, causing an abnormal noise to be produced from the motor. In such a case, lessen parameter F-20 until no abnormal noise is produced. Lessening F-20 makes the deceleration period long.

4.7 Speed Overshooting or Hunting Occurs

Item	Causes	Check procedure	Remedy
1	Overshooting		Enlarge F-21 or F-22. (Note)
2	Spindle hunting		Lessen F-21 or F-22. (Note)

Note) Refer to section 5.4.

4.8 Cutting Force is Low

Item	Causes	Check procedure	Remedy
1	ROM is not proper.	Check series No. of ROM.	Replace ROM. (Note)
2	Torque limit command is applied.	Check torque limit signal.	Release of command.

Note) Refer to the Table 1.2 (a) - (c).

4.9 Orientation is not Correct

Item	Causes	Check procedure	Remedy
1	Setting or adjusting failure of spindle orientation control circuit.		Re-adjustment. (Note 1)
2	Spindle orientation control circuit is defective.		Replace PCB. (Note 2)
3	Spindle control circuit is defective.		Replace PCB. (Note 2)
4	Position coder or magnetic sensor is defective.	Check the output signal waveform. (Note 3)	Replace the position coder or magnetic sensor.

Note 1) Refer to chapter 7.

Note 2) Refer to section 6.3.

Note 3) When magnetic sensor, refer to Appendix 10.

4.10 Acceleration/Deceleration Time is Long

Item	Causes	Check procedure	Remedy
1	Torque limit command is applied.	Check signal.	Release of command.
2	Defective receiver part activates the torque limit.	Check whether or not the acceleration/ deceleration time changes if the value of parameter F-18 is changed.	Replace receiver or PCB. (Note 1)
3	PCB is not adjusted correctly.	Check if the value of parameter F-20 is smaller than necessary, or has not been set. (Note 3)	Readjust F-20. (Note 2)

Note 1) Refer to chapter 6.

Note 2) Refer to section 4.6.

Note 3) Refer to section 5.4.

5. SETTING AND ADJUSTING

5.1 Models 1S - 3S

Refer to Appendix 6 for part locations of the unit and PCB. Always confirm the location of parts on PCB before power on.

5.1.1 Setting pin

Table 5.1 (a) List of setting pin

Jumper	Contents	State			Setting at shipment
		Test mode	TEST	DRIVE	
S1	Switches mode of control circuit	Operation mode	DRIVE		DRIVE
		Detector I (rpm)	Detector II (rpm)		
S2 S3	Selects from right table according to the speed at (VCMD = 10 V) Detector I: Gear of 256 teeth Detector II: Gear of 128 teeth		6000	D	Depends upon model.
		4500	8000	C	
		6000	10000 to 12000	B	
		8000 to 10000	15000 to 20000	A	
S4 S5	Switches gain	Normal operation mode	OFF		OFF
		Switches gain	ON		
S6A S6B	Characteristic during orientation. (Reduce unsteadiness when using built-in sensor signal conversion circuit and setting pin is stopped.)	Standard	OFF		OFF
		When using built-in sensor signal conversion circuit	ON		
SH (Note 1)	Change of parameter setting forbidden.	Operation mode	DRIVE		DRIVE
		When changing setting.	SET		

Note 1) PCB version number applies to 13B and later.

Note 2) PCB version number applies to 21B and later.

(Setting at shipment of S2, S3)

ROM stamp	9801	9802	9803	9805	9808	9809	9810
State	C	C	D	A	C	D	C

5.1.2 Variable resistor

Table 5.1 (b) List of variable resistor

Variable resistor	Contents	Setting at shipment		
RV1	Maximum speed in CCW direction	Depends upon model.		
RV2	Maximum speed in CW direction			
RV3	Offset of speed detection circuit	Adjust TS3 to 0 mV \pm 0.1 mV at rotation command OFF.		
RV4	Voltage of +5 V	+5 V \pm 0.1 V		
RV5	Adjusts gain at switching of gain	50%		
RV6	Gain of speed detection circuit for low speed range	Model	Value (rpm)	Max. speed (rpm)
	Adjusts speed at 25 mV \pm 2 mV of VCMD for each model	3S	15 \pm 3	6000
		1S - 2S	20 \pm 4	8000

5.2 Models 6S - 26S

Regarding the installation position of the setting jumper, refer to the parts arrangement diagram (Appendix 6).

Further, before power on, check the state of the setting jumper which is on the PCB.

a) Setting jumper (PCB version number 09A and before)

Table 5.2 (a) Setting jumper list (PCB version number 09A and before)

Jumper	Contents	State		Setting at shipment
S1	Control circuit mode switching	Test mode	TEST	DRIVE
		Normal operation mode	DRIVE	
S2	For power margin test	Increases +5 V power voltage by 10%	+ 10	Without setting
		Decreases +5 V power voltage by 10%	- 10	
S5	Using (EXT)/not using (INT) electromagnetic contactor external interruption	Uses MOFF signal	EXT	INT
		Does not use MOFF signal	INT	
S6	Presence/absence of power supply to outside (Supply at ON)	S6A: +24 V		Without setting (Without supplying)
		S6B: +5 V		
		S6C: -15 V		

b) Setting jumper (PCB version number 10B and later)

Table 5.2 (b) Setting jumper (PCB version number 10B and later)

Jumper	Contents	State		Setting at shipment
S1	Control circuit mode switching	Test mode	TEST	DRIVE
		Normal operation mode	DRIVE	
S2	For power margin test	Increases +5 V power voltage by 10%	H	Without setting
		Decreases +5 V power voltage by 10%	L	
S5	Set the electromagnetic contactor (MCC) to interrupt unconditionally.	Interrupts MCC (Note 1)	OFF	ON
		Does not interrupt MCC	ON	

Jumper	Contents	State		Setting at shipment
S7	Setting related to power supply to speed detector	Directly outputs +5 V of power to speed detector (Note 2)	A	B
		Outputs standard 5 V power derived from the +15 V power supply to the speed detector	B	
S8	Setting related to orientation characteristics (Note 3)	A		B
		B		

Note 1) Can also be used when observing the switching waveform of drive circuit of power transistor.

However, exercise sufficient caution when observing because there is a high voltage in connectors CN4-6, including the drive circuit also.

Note 2) Used when directly supplying a +5 V supply to the signal conversion circuit from connector CN2.

However, set according to the function version number of the signal conversion circuit. Refer to chapter 11.

Note 3) When a flutter occurs at orientation, there are cases when the flutter can be made small by means of setting to the B side.

5.3 Parameter Setting Method

The various parameter setting switches and display part are installed in the PCB of the AC spindle servo unit S series. (Refer to Appendix 6.)

Checking and changing the data contents for the various parameters are performed by operating this switch.

- 1) To confirm the current parameter
 - a) The speed is usually displayed at the display part (Five digits).
The current parameter number can be displayed when "MODE" is on. The parameter number is displayed as two digits of "F-XX".
- 2) To confirm the parameter data

Select the parameter number of data to be checked in the following manner.

 - a) Continuously turn 4 switches "MODE", "+ UP", "+ DOWN" and "DATA SET" ON at the same time for more than one second.
 - b) The display part changes from the blank to "FFFFF".
 - c) Off all switches.
 - d) The current parameter is displayed when "MODE" is on.
 - e) When "+ UP" is on with "MODE" on, the parameter number is incremented by 1.
 - f) When "+ UP" is continuously on with "MODE" on, the parameter number increases continuously.
 - g) When "+ DOWN" is on with "MODE" on, the parameter number is decremented by 1.
 - h) When "+ DOWN" is continuously on with "MODE" on, the parameter number decrements continuously.
 - i) With "MODE" off, the data is displayed (4 digits) after approx. 0.5 second.
 - j) After approx. 10 seconds the data display is selected, the speed display is selected.

3) To alter the data

Note) When models 1S - 3S, before step a), alter the data according to the following steps after setting the setting jumper to the "SET" side.

- a) Select the parameter to be changed according to the steps 2)-a) to h).
- b) Turn "MODE" off: The data of parameter is displayed after approx. 0.5 second.
- c) Turn "+ UP" on: The data is incremented by 1.
- d) Turn "+ UP" on continuously: The data is incremented continuously.
- e) Turn "+ DOWN" on: The data is decremented by 1.
- f) Turn "+ DOWN" on continuously: The data is decremented continuously.
- g) The motor is controlled using the displayed data.
- h) When replacing the data with the modified data, keep turning "DATA SET" on for one second or more.

Note) However, in the state in which the rotation direction command (SFR/SRV: ON) has been inputted, this operation will not be accepted. When replacing the data after altering by changing the data, be certain to set OFF the rotation direction command.

- i) The display part changes from the blank to "88888" and modification of the data completes.
- j) When changing the data once again, follow the steps from (3)-(a) above.
- k) The speed is indicated automatically after about 10 seconds. For parameters F-13, F-14 and F30, speed is displayed after 2 seconds.

5.4 Number and Contents of Parameter

When models 1S - 3S, there are parameters which are not used.
In P series, use the unit for models 6S - 26S.

1) Motor speed indication

Parameter No.	Display data (Five digits)	Contents of data
F-00		The speed of the motor is displayed. (rpm)

2) Use/no use of the machine ready signal (MRDY)

Parameter No.	Display data (Five digits)	Contents of data
F-01	0001	0, 1 (Standard setting: 0)

Explanation: Machine ready signal (MRDY) is used : 1
Machine ready signal (MRDY) is not used: 0

3) Use/no use of speed override (models 6S - 26S)

Parameter No.	Display data (Four digits)	Contents of data
F-02	0001	0, 1 (Standard setting: 1)

Explanation: Use speed override : 1
Not use speed override: 0

4) Range of speed override (models 6S - 26S)

Parameter No.	Display data (Four digits)	Contents of data
F-03	0001	0, 1 (Standard setting: 1)

Explanation: Upper limit of speed override (up to 120%): 1
 Upper limit of speed override (up to 100%): 0

Note) When F-02 is set to 0; speed override is not used, this setting should be set to 0.

5) Maximum speed (models 6S - 26S)

Parameter No.	Display data (Four digits)	Contents of data
F-05		0 - 3 (Depend upon motor)

Explanation: This sets the level of the speed feedback voltage. The difference between the standard specifications and high-speed specifications is whether the speed detector is 256 pulses/1 rotation (standard specifications) or 128 pulses/1 rotation (high-speed specifications). Therefore, in high-speed specifications the feedback voltage is the same as for a speed of double the standard specifications.

Standard specifications	High-speed specifications	Setting jumper
3900 - 5000 rpm	7800 - 10000 rpm	0
4900 - 6300 rpm	9800 - 12600 rpm	1
6200 - 8200 rpm	12400 - 16400 rpm	2
8000 - 10000 rpm	16000 - 20000 rpm	3

If it is below the maximum speed of the motor specifications, the maximum speed can be adjusted to a chosen value. However, less than 3900 rpm cannot be set in standard specifications, or less than 7800 rpm in high-speed specifications. When adjusted such that the maximum speed differs from specifications of motor, be certain to change the data of parameter F-15 to the adjusted value.

6) Output limit pattern

Parameter No.	Display data (Four digits)	Contents of data
F-06	0000	0 to 6 (Standard setting: 0) (Note)

Note) There are cases when a value different from that at shipment is set.

Explanation: This function is not available for a conventional type. In the following cases, select a pattern which is appropriate respectively.

- A. When the output is limited only at acceleration and deceleration, the motor accelerates and decelerates slowly, and operates at the rated output during steady rotation (Setting data: 1 or 4) (function similar to software start and stop)
- B. When the motor accelerates and decelerates at the maximum rated output and the output is limited during stable rotation (Setting data: 2 or 5)
- C. When the same motor and amplifier are used to operate the machine as a different output specification machine (Setting data: 3 or 6)

(Output limit pattern 1)

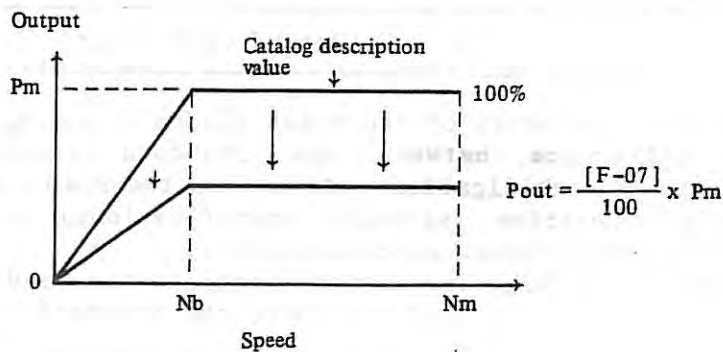

(Output limit pattern 2)

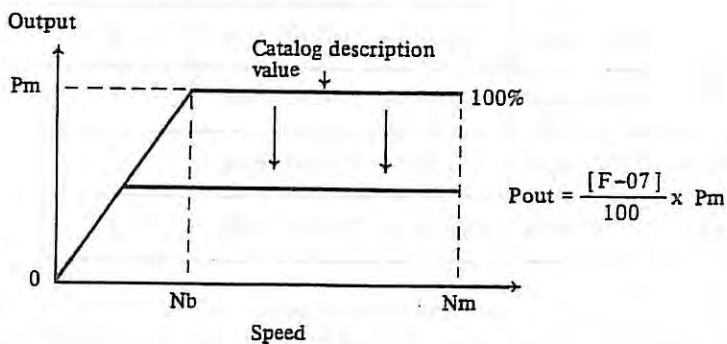

Content	Setting data	
	Pattern 1	Pattern 2
The output is not limited.	0	0
Pattern A	1	4
Pattern B	2	5
Pattern C	3	6

7) Limit value at output limited

Parameter No.	Display data (Four digits)	Contents of data
F-07	0100	0 to 100 (Standard setting: 100)

Explanation: With the maximum rated output (1.2 multiple of 30-minute rating) as 100%, set the limit value to a value to be limited. This value is available when the output is limited due to parameter F-06.

$$\text{Output limit value} = \text{Maximum rated output} \times (\text{setting data}) \%$$

(Loadmeter display at output limit)

When output limiting by F-06 and 07, the loadmeter output is outputted as regulated to the output limit value of 10 V.

8) Delay time to motor power interruption

Parameter No.	Display data (Four digits)	Contents of data
F-08	0005	0 to 255 (Standard setting: 5)

Explanation: The motor power is interrupted by the motor stopping. It is interrupted by strictly detecting zero speed. Zero speed may also be set, but the motor speed is detected at less than 0.75% of the maximum rotation speed. If the power is interrupted immediately after detecting zero speed, set the time from detecting zero speed up until the motor power interruption by this parameter because the motor runs idly at low speed. When the load inertia of the spindle is large, set a large value.

$$\text{Delay time} = (\text{Setting data}) \times 40 \text{ msec}$$

9) Use/no use of excitation interruption of motor power using machine ready signal (MRDY)

Parameter No.	Display data (Four digits)	Contents of data
F-09	0000	0, 1 (Standard setting: 0)

Explanation: The function is used when it is presumed that the electromagnetic contactor is switched frequently. When the machine ready signal (MRDY) is off, only motor power is interrupted. The function is used : 1
The function is not used: 0

(Using the function)

When performing spindle orientation and ATC operation, if tool unclamp is performed, the spindle will be locked. At this time, if locked in a state in which the stop position has slightly slipped, the motor attempts to return to the original position and a large current flows. Because of this, there are cases in which the loadmeter vibrates greatly and the transistor module is damaged. Therefore when performing tool unclamp, use this function.

- 10) Adjustment of speed error offset at the time of the forward rotation command (SFR)

Parameter No.	Display data (Four digits)	Contents of data
F-10	0128	0 - 255 (Standard setting: 128)

Explanation: The speed error offset is adjusted when stopping motor with the forward rotation command (SFR) and speed command voltage (VCMD) 0 V (zero rotation command) applied. Increase the data when stopping the motor rotating counterclockwise (CCW), as viewed from the shaft.

- 11) Adjustment of speed error offset at the time of the reverse rotation command (SRV)

Parameter No.	Display data (Four digits)	Contents of data
F-11	0128	0 - 255 (Standard setting: 128)

Explanation: The speed error offset is adjusted when stopping motor with the reverse rotation command (SRV) and speed command voltage (VCMD) 0 V (zero rotation command) applied. Increase the data when stopping the motor rotating CCW, as viewed from the shaft.

- 12) Adjustment of speed error offset at the time of the orientation command (ORCM)

Parameter No.	Display data (Four digits)	Contents of data
F-12	0128	0 - 255 (Standard setting: 128)

Explanation: Normally it is not necessary to adjust this parameter. Offset at orientation stop is performed by a variable resistor (volume) on the orientation circuit, and adjustment is performed by this parameter when it cannot be adjusted. When performing adjustment by this parameter, the offset adjustment volume of the orientation circuit is adjusted such that IN-POSITION FINE lights in the state set at the 5th division.

- 13) Speed at forward rotation command (SFR) (Models 6S - 26S)

Parameter No.	Display data (Four digits)	Contents of data
F-13		0 - 255 (Depends upon motor)

Explanation: Adjust the speed when inputting specific speed command at forward rotation command (SFR). Increase data to increase speed.

14) Speed at reverse rotation command (SRV) (Models 6S - 26S)

Parameter No.	Display data (Four digits)	Contents of data
F-14		0 - 255 (Depends upon motor)

Explanation: Adjust the speed when inputting specific speed command at reverse rotation command (SRV). Increase data to increase speed.

Refer to section 5.1 for models 1S - 3S.

15) Speed when speed command voltage (VCMD) is 10 V

Parameter No.	Display data (Four digits)	Contents of data
F-15		40 - Rated speed (Depends upon motor)

Note) Don't set the value of 40 or less.

Explanation: When making adjustments in F-05, F-13 and F-14, always set this mode. Set the value of speed at 10 V speed command voltage (VCMD) divided by 100.

Setting data = Speed at 10 V speed command voltage (rpm) ÷ 100

16) Detection range of speed arrival signal (SAR)

Parameter No.	Display data (Four digits)	Contents of data
F-16	0015	0 - 100 (Standard setting: 15)

Explanation: Sets the detection range of the speed arrival signal (SAR). The speed arrival signal (SAR) is outputted when the motor speed reaches the range within specific percentage of the command speed.

Detection range = (Command speed) x
within (± (Setting data)) %

17) Detection range of speed detecting signal (SDT)

Parameter No.	Display data (Four digits)	Contents of data
F-17	0003	0 - 100 (Standard setting: 3)

Explanation: The detection range of the speed detecting signal (SDT) is set.

The speed detecting signal (SDT) is outputted when the motor speed becomes the specific percentage of a maximum speed or less.

This signal is used as the switching speed detecting signal at output switching control.

Refer to the specifications manual (B-65012E).

Detection range = (Maximum speed) x (Setting data) % or less

18) Setting of torque limit value

Parameter No.	Display data (Four digits)	Contents of data
F-18	0050	0 - 100 (Standard setting: 50)

Explanation: When the torque limit signal (TLMH) is turned on, torque limit value is set.

(When TLML is ON, this limit value becomes half.)

Torque limit value = Maximum rated torque (1.2 times 30 min. rated torque) x (Setting data) %

19) Acceleration/deceleration time

Parameter No.	Display data (Four digits)	Contents of data
F-19	0010	0 - 255 (Standard setting: 10)

Explanation: Set this parameter when the load inertia is large and the acceleration time from stop to the maximum speed is longer than 5 seconds.

Setting value = (Acceleration time, sec) x 2

20) Limit of regenerative power (Adjustment of deceleration time)

Parameter No.	Display data (Four digits)	Contents of data
F-20	0040	0 - 100 (Setting at shipment differs according to motor.) (Note)

Note) Standardly, 40 is set.

Explanation: Adjust the deceleration time to the same as the acceleration time.

The deceleration time shortens when the setting value increases.

The deceleration time lengthens when the setting value decreases.

However, when the regenerative power is excessive, the regenerative limit circuit is actuated and the motor current waveform changes; therefore, abnormal noise may be produced from the motor. In this case, this abnormal noise is suppressed by decreasing the setting value. (The deceleration time becomes longer.)

The values of F-21 - 28 shown here are the standard values of the models 6S - 26S.

Regarding models 1S - 3S and P series, there are differing cases.
(Refer to Appendix 10.)

21) Speed control phase compensation P: HIGH gear (CTH = 1)

Parameter No.	Display data (Four digits)	Contents of data
F-21	0050	0 - 255 (Standard setting: 50)

22) Speed control phase compensation P: LOW gear (CTH = 0)

Parameter No.	Display data (Four digits)	Contents of data
F-22	0050	0 - 255 (Standard setting: 50)

23) Speed control phase compensation P in orientation: HIGH gear (CTH = 1)

Parameter No.	Display data (Four digits)	Contents of data
F-23	0100	0 - 255 (Standard setting: 100)

24) Speed control phase compensation P in orientation: LOW gear (CTH = 0)

Parameter No.	Display data (Four digits)	Contents of data
F-24	0100	0 - 255 (Standard setting: 100)

25) Speed control phase compensation I: HIGH gear (CTH = 1)

Parameter No.	Display data (Four digits)	Contents of data
F-25	0030	0 - 255 (Standard setting: 30)

26) Speed control phase compensation I: LOW gear (CTH = 0)

Parameter No.	Display data (Four digits)	Contents of data
F-26	0030	0 - 255 (Standard setting: 30)

27) Speed control phase compensation I in orientation: HIGH gear (CTH = 1)

Parameter No.	Display data (Four digits)	Contents of data
F-27	0030	0 - 255 (Standard setting: 30)

28) Speed control phase compensation I in orientation: LOW gear (CTH = 0)

Parameter No.	Display data (Four digits)	Contents of data
F-28	0030	0 - 255 (Standard setting: 30)

29) Speed detection offset (models 6S - 26S)

Parameter No.	Display data (Four digits)	Contents of data
F-29	0128	0 - 255 (Initial setting: approx. 128)

Explanation: Adjust this parameter so that the test pin TS3 will be 0 mV at motor stopping.

30) Rigid tap mode

Parameter No.	Display data (Four digits)	Contents of data
F-31	0000	0 - 1 (Standard setting: 0)

Explanation: The torque limit signal (TLML) is used to a conventional torque limit: 0
The torque limit signal (TLML) is used for motor voltage switching when improved transient response characteristics are required for rigid tapping operation: 1

31) Motor voltage at normal operation

Parameter No.	Display data (Four digits)	Contents of data
F-32	0010	0 - 100 (Standard setting: 10)

32) Motor voltage in orientation

Parameter No.	Display data (Four digits)	Contents of data
F-33	0010	0 - 100 (Standard setting: 10)

33) Motor voltage in rigid tap mode

Parameter No.	Display data (Four digits)	Contents of data
F-34	0100	0 - 100 (Standard setting: 100)

Explanation: This parameter is effective when data of F-31 is 1.

34) Setting of detection range of zero-speed signal. (SST)

Parameter No.	Display data (Four digits)	Contents of data
F-35	0075	0 - 255 (Standard setting: 75)

Explanation: The zero-speed signal SST is used as the completion signal for stop command.
This signal is detected when the speed of the motor becomes (The setting data/100)% of a maximum speed or less.

$$\text{The detection range} = (\text{maximum speed}) \times (\text{The setting data}/100)\% \text{ or less}$$

35) Detection range of load detection signal (LDT)

Parameter No.	Display data (Four digits)	Contents of data
F-36	0090	0 - 100 (Standard setting: 90)

Explanation: The load is detected when the load becomes greater than the specific percentage of maximum detection level of the load meter.

$$\text{Detection level} = (\text{maximum detection level of load meter, 10}) \times (\text{setting data})\% \text{ or more}$$

(Load detection signal (LDT) during acceleration/deceleration)
During acceleration/deceleration, the loadmeter instruction reaches the maximum detection level, but in this case the time preset by F-19 is not outputted. However, there are cases when it is outputted when changing minute speed commands (less than 50 mV).

36) Time constant of torque deviation at deceleration start (models 6S - 26S)

Parameter No.	Display data (Four digits)	Contents of data
F-37	0000	0 - 3 (Standard setting: 0)

Explanation: Use this parameter when the gear noises at deceleration in low speed rotation (base speed) due to the backlash of the spindle.

Data	Time constant (msec)
0 :	0
1 :	50
2 :	100
3 :	150

Set the data to 2 when the gear noises.

37) Characteristics of control in deceleration (models 6S - 26S)

Parameter No.	Display data (Four digits)	Contents of data
F-38	0000	0, 1 (Standard setting: 0)

Explanation: Use this parameter when the gear noises at deceleration in high speed rotation. Set the data to 1 to slow down the deceleration rate.

38) Characteristics of control in stable rotation with no load (models 6S - 26S)

Parameter No.	Display data (Four digits)	Contents of data
F-39	0000	0, 1 (Standard setting: 0)

Explanation: The motor speed may undulate in the stable rotation when setting the motor voltage (F-32) greater than the standard value (10). Set F-39 to 1 to reduce the motor undulation.

39) Characteristics of control in torque limitation (models 6S - 26S)

Parameter No.	Display data (Four digits)	Contents of data
F-40	0000	0, 1 (Standard setting: 0)

Explanation: The motor speed may overshoot due to the timing of the torque limit signal when making the torque limit in mechanical orientation. Set F-40 to 1 to reduce the overshoot of the speed.

F-41 - 53 are the parameters relating to the motor characteristics. Therefore, set such that the data is not changed.

40) Current loop I gain

Parameter No.	Display data (Four digits)	Contents of data
F-41		Differs according to motor specifications.

41) Slip compensation constant

Parameter No.	Display data (Four digits)	Contents of data
F-42		Differs according to motor specifications.

42) Slip constant

Parameter No.	Display data (Four digits)	Contents of data
F-43		Differs according to motor specifications.

43) Voltage compensation

Parameter No.	Display data (Four digits)	Contents of data
F-44		Differs according to motor specifications.

44) PWM maximum amplitude

Parameter No.	Display data (Four digits)	Contents of data
F-45		Differs according to motor specifications.

45) Second current command

Parameter No.	Display data (Four digits)	Contents of data
F-46		Differs according to motor specifications.

46) Current assumed constant

Parameter No.	Display data (Four digits)	Contents of data
F-47		Differs according to motor specifications.

47) Fixed torque point

Parameter No.	Display data (Four digits)	Contents of data
F-48		Differs according to motor specifications.

48) Excitation weak point

Parameter No.	Display data (Four digits)	Contents of data
F-49		Differs according to motor specifications.

49) Voltage conversion constant

Parameter No.	Display data (Four digits)	Contents of data
F-50		Differs according to motor specifications.

50) Selection of speed detector

Parameter No.	Display data (Four digits)	Contents of data
F-51		Differs according to motor specifications.

51) Current conversion constant

Parameter No.	Display data (Four digits)	Contents of data
F-52		Differs according to motor specifications.

52) Current loop P gain

Parameter No.	Display data (Four digits)	Contents of data
F-53		Differs according to motor specifications.

When the data of F-41 - 53 has been changed mistakenly, reset the data by the following method.

(Setting method of standard data)

In accordance with the following procedure, reset the standard data.

By means of this operation, the data is written to NVRAM (non-volatile RAM).

Further, before the operation, check whether or not the setting differs from the standard data, and it would be advisable to record it.

- (1) Set OFF the power. (Note)
- (2) Change the setting of the setting jumper S1 to the "TEST" side.
- (2)' In models 1S - 3S, for PCB version numbers 13B and later, change the setting jumper SH to the "SET" side; for those earlier, change the setting jumper SH on its PCB to the "SET" side when there is a back PCB.
- (3) Set ON the power.
- (4) Select FC-22. (Refer to 5.3(2).)
- (5) Set ON "DATA SET" for more than 1 second.
- (6) If "Good" is displayed, this indicates that the setting of the standard data is completed.
- (7) Set OFF the power. (Note)
- (8) Change the setting of the setting jumper S1 to the "DRIVE" side.
- (9) Set ON the power.
- (10) Adjust parameter F-29 (speed detection offset) by motor stop.
- (11) Then, set parameters that differ from setting at shipment.
- (12) After parameter setting and adjustment, set ON "DATA SET" for more than 1 second.
- (13) Set OFF the power. (Note)
- (13)' In models 1S - 3S, for PCB version numbers 13B and later, change the setting jumper SH to the "DRIVE" side; for those earlier, change the setting jumper SH on its PCB to the "DRIVE" side when there is a back PCB.

(14) Set ON the power.

(15) Check the operation.

Note) When changing the setting of setting jumpers S1 and SH, be certain to set OFF the power.

5.5 Setting Rank

Rank A: Absolutely necessary to check

Rank B: When changing speed

Rank C: When performing special setting

5.5.1 Models 1S - 3S

Rank	Parameter No.	Contents
A	F-01	Use/no-use of the machine ready signal (MRDY)
B	F-15	Speed setting at speed command voltage 10 V
C	F-16	Range of detecting the speed arrival signal (SAR)
	F-17	Level of detecting the speed detection signal (SDT)
	F-35	Level of detecting the zero-speed signal (SST)
	F-18	Torque limit value
	F-06, 07	Output limit pattern
	F-19	Period of acceleration/deceleration
	F-20	Limit of regenerative power (deceleration time)
	F-09	Use/no-use of motor power off using the machine ready signal
	F-36	Level of detecting the load detection signal (LDT)

5.5.2 Models 6S - 26S

Rank	Parameter No.	Contents
A	F-01	Use/no-use of machine ready signal (MRDY)
	F-02	Use/no-use of speed override
	F-03	Range of speed override
B	F-05	Setting of maximum speed
	F-13	Speed at forward command (SFR)
	F-14	Speed at reverse command (SRV)
	F-15	Speed at speed command voltage (VCMD) (10 V)
C	F-16	Range of detecting the speed arrival signal (SAR)
	F-17	Level of detecting the speed detection signal (SDT)
	F-35	Level of detecting zero speed signal (SST)
	F-18	Torque limit value
	F-06, 07	Setting of output limit pattern
	F-19	Period of acceleration/deceleration
	F-20	Limit of regenerative power (deceleration time)
	F-09	Use/no-use of motor power off using the machine ready signal
	F-36	Setting of level of load detection signal (LDT)

5.6 Setting and Adjusting Spindle Orientation Control Circuit

Refer to section "Spindle orientation control circuit."

6. REPLACING FUSE AND PCB

When replacing the fuses and PCB, this must be carried out after checking that the power is OFF.

6.1 Replacing Fuse

Refer to the parts arrangement diagrams in Appendices 5 and 6 for the installation position of the fuses.

When replacing the fuses, this must be carried out after checking that the power is OFF.

6.2 Replacing PCB

The printed board of the AC spindle servo unit S series is configured by the 2 boards of the control circuit and wiring board.

When replacing the PCB, carry out after checking that the charging display LED is extinguished and that the voltage between the electrolytic condenser terminals is less than 60 VDC.

Steps	Contents
1	Set OFF the supply of AC power (set OFF magnetics board breaker), and remove the cables connected to the unit. (Refer to Appendix 2.)
2	Pull out the control circuit towards you while extending the PCB holder to the outside.
3	Replace the wiring board by removing all the screws fastening parts such as the transistor module. After replacing, be certain to check that the screws are tightened.

6.3 Replacing option (orientation, spindle switching, speed range switching) PCB

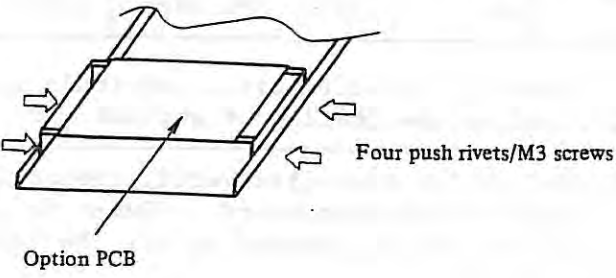
Steps	Contents
1	Set OFF the supply of AC power (set OFF magnetics board breaker), and remove the cables connected to the unit. (Refer to Appendix 2.)
2	Detach by pulling out the control circuit towards you while extending the PCB holder to the outside, and remove the flat cable between the option circuit and PCB.
3	Remove the 4 push rivets (or screws) fastening the option circuit PCB sheet metal. 

The assembly method after replacement is the reverse of the above procedure.

6.4 Replacing Transistor Module

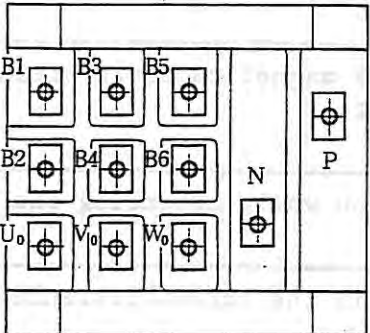
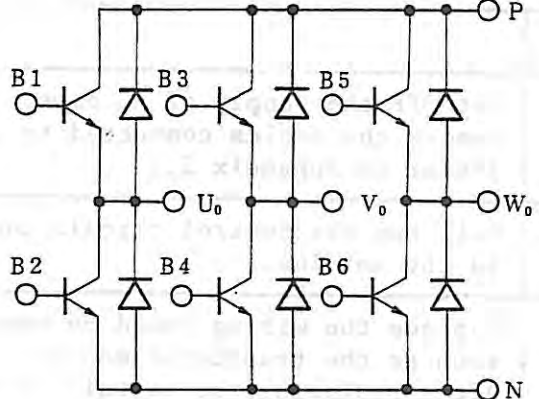
Steps	Contents																									
1	Turn off the breaker on the magnetics cabinet to off the AC input power, and then remove the cable connected to the unit.																									
2	<p>Check resistance of transistor modules on the distributing board PCB using a tester. Refer to Appendix 6.</p> <ol style="list-style-type: none"> 1. ⊕ (P) (collector) - U₀, V₀, W₀ (emitter) 2. U₀, V₀, W₀ (collector) - ⊖ (N) (emitter) 3. ⊕ (P) (collector) - B1, B3, B5 (base) 4. U₀, V₀, W₀ (collector) - B2, B4, B6 (base) 5. B1, B3, B5 (base) - U₀, V₀, W₀ (emitter) 6. B2, B4, B6 (base) - ⊖ (N) (emitter) <div style="display: flex; justify-content: space-around; align-items: center;">   </div> <p>Judgment (Range of tester: x 10 ohm)</p> <table border="1" data-bbox="215 1172 1193 1625"> <thead> <tr> <th>Terminal</th> <th>Tester</th> <th>Normal</th> <th>Abnormal</th> </tr> </thead> <tbody> <tr> <td rowspan="2">C - E ① ②</td> <td>C: +</td> <td>500 - 600 ohms <i>260</i></td> <td>Short, infinity</td> </tr> <tr> <td>C: -</td> <td>Infinity</td> <td>Short, 500 - 600 ohms</td> </tr> <tr> <td rowspan="2">C - B ③ ④</td> <td>C: +</td> <td>500 - 600 ohms</td> <td>Short, infinity</td> </tr> <tr> <td>C: -</td> <td>Infinity</td> <td>Short, 500 - 600 ohms</td> </tr> <tr> <td rowspan="2">B - E ⑤ ⑥</td> <td>B: +</td> <td>500 - 600 ohms</td> <td>Short, infinity</td> </tr> <tr> <td>B: -</td> <td>500 - 600 ohms</td> <td>Short, infinity</td> </tr> </tbody> </table> <p>When a transistor is defective, terminals between collector and emitter, and between collector and base are short.</p>	Terminal	Tester	Normal	Abnormal	C - E ① ②	C: +	500 - 600 ohms <i>260</i>	Short, infinity	C: -	Infinity	Short, 500 - 600 ohms	C - B ③ ④	C: +	500 - 600 ohms	Short, infinity	C: -	Infinity	Short, 500 - 600 ohms	B - E ⑤ ⑥	B: +	500 - 600 ohms	Short, infinity	B: -	500 - 600 ohms	Short, infinity
Terminal	Tester	Normal	Abnormal																							
C - E ① ②	C: +	500 - 600 ohms <i>260</i>	Short, infinity																							
	C: -	Infinity	Short, 500 - 600 ohms																							
C - B ③ ④	C: +	500 - 600 ohms	Short, infinity																							
	C: -	Infinity	Short, 500 - 600 ohms																							
B - E ⑤ ⑥	B: +	500 - 600 ohms	Short, infinity																							
	B: -	500 - 600 ohms	Short, infinity																							
3	<p>After a defect has been discovered, replace the part. First, remove the wiring board. (Refer to section 6.2.) When replacing the transistor module, be certain to apply silicon grease. (Note)</p>																									

Note) Use the Shinetsu Kagaku Kogyo Co. product G-746.

Steps	Contents																																																																																																																								
4	After replacement, install the wiring board, and tighten all the screws. Check that the screws have been tightened. Next, recheck according to step 2.																																																																																																																								
5	<p>Install the control PCB, and check the transistor driver circuit.</p> <p>① Set ON the AC power. Do not input the rotation direction command (SFR, SRV).</p> <p>② Measure the voltage between the base and emitter of each transistor (U, V, W phases) by using the tester at the connector.</p> <p>Take sufficient care about electric shocks because there is a high-voltage (300 VDC) section in each connector and its surroundings. Further, take care not to scratch the connectors.</p> <p>Connector signal arrangement</p> <p>(1) Measures by models 1S - 3S CN5.</p> <p>CN5</p> <table border="1" data-bbox="320 787 1290 915"> <tr><td>1</td><td>2</td><td>3</td><td>4</td><td>5</td><td>6</td><td>7</td><td>8</td><td>9</td><td>10</td><td>11</td><td>12</td><td>13</td><td>14</td><td>15</td></tr> <tr><td>BG</td><td>EG</td><td>CG</td><td></td><td>U0</td><td>B1</td><td>B2</td><td>B4</td><td>B3</td><td>V0</td><td>B5</td><td>B6</td><td>W0</td><td></td><td></td></tr> </table> <p>Measurement location (The side underlined is taken as standard)</p> <p>① B1-<u>U0</u> ④ B2-<u>EG</u> ⑦ BG-<u>EG</u> ② B3-<u>V0</u> ⑤ B4-<u>EG</u> ③ B5-<u>W0</u> ⑥ B6-<u>EG</u></p> <p>(2) Measures by models 6S - 26S CN4, 5, 6.</p> <p>CN4</p> <table border="1" data-bbox="320 1190 1290 1318"> <tr><td>1</td><td>2</td><td>3</td><td>4</td><td>5</td><td>6</td><td>7</td><td>8</td><td>9</td><td>10</td><td>11</td><td>12</td><td>13</td><td>14</td><td>15</td></tr> <tr><td></td><td></td><td>B1</td><td>B3</td><td>B5</td><td>B2</td><td>B4</td><td>B6</td><td>N1</td><td>U0</td><td>V0</td><td>W0</td><td></td><td></td><td></td></tr> </table> <p>CN5</p> <table border="1" data-bbox="320 1397 1290 1526"> <tr><td>1</td><td>2</td><td>3</td><td>4</td><td>5</td><td>6</td><td>7</td><td>8</td><td>9</td><td>10</td><td>11</td><td>12</td><td>13</td><td>14</td><td>15</td></tr> <tr><td>PO</td><td></td><td>B2R</td><td>B4R</td><td>B6R</td><td>N2</td><td>N2</td><td>R2</td><td>S2</td><td>T2</td><td></td><td></td><td>P</td><td>P</td><td></td></tr> </table> <p>CN6</p> <table border="1" data-bbox="320 1605 1290 1734"> <tr><td>1</td><td>2</td><td>3</td><td>4</td><td>5</td><td>6</td><td>7</td><td>8</td><td>9</td><td>10</td><td>11</td><td>12</td><td>13</td><td>14</td><td>15</td></tr> <tr><td></td><td></td><td></td><td></td><td></td><td></td><td></td><td></td><td></td><td></td><td>B1R</td><td>B3R</td><td>B5R</td><td></td><td></td></tr> </table> <p>Measurement location (The side underlined is taken as standard)</p> <p>① B1-<u>U0</u> ⑦ B5R-<u>R2</u> ② B3-<u>V0</u> ⑧ B3R-<u>S2</u> ③ B5-<u>W0</u> ⑨ B1R-<u>T2</u> ④ B2-<u>N1</u> ⑩ B6R-<u>N2</u> ⑤ B4-<u>N1</u> ⑪ B4R-<u>N2</u> ⑥ B6-<u>N1</u> ⑫ B2R-<u>N2</u></p>	1	2	3	4	5	6	7	8	9	10	11	12	13	14	15	BG	EG	CG		U0	B1	B2	B4	B3	V0	B5	B6	W0			1	2	3	4	5	6	7	8	9	10	11	12	13	14	15			B1	B3	B5	B2	B4	B6	N1	U0	V0	W0				1	2	3	4	5	6	7	8	9	10	11	12	13	14	15	PO		B2R	B4R	B6R	N2	N2	R2	S2	T2			P	P		1	2	3	4	5	6	7	8	9	10	11	12	13	14	15											B1R	B3R	B5R		
1	2	3	4	5	6	7	8	9	10	11	12	13	14	15																																																																																																											
BG	EG	CG		U0	B1	B2	B4	B3	V0	B5	B6	W0																																																																																																													
1	2	3	4	5	6	7	8	9	10	11	12	13	14	15																																																																																																											
		B1	B3	B5	B2	B4	B6	N1	U0	V0	W0																																																																																																														
1	2	3	4	5	6	7	8	9	10	11	12	13	14	15																																																																																																											
PO		B2R	B4R	B6R	N2	N2	R2	S2	T2			P	P																																																																																																												
1	2	3	4	5	6	7	8	9	10	11	12	13	14	15																																																																																																											
										B1R	B3R	B5R																																																																																																													

Steps	Contents				
5	<p>Judgment (Voltage between base and emitter, emitter standard)</p> <table border="1" data-bbox="389 307 1022 440"> <tr> <td data-bbox="389 307 588 371">Normal</td> <td data-bbox="588 307 1022 371">Approx. -0.8 V to -1.3 V</td> </tr> <tr> <td data-bbox="389 371 588 440">Abnormal</td> <td data-bbox="588 371 1022 440">Approx. 0.0 V to -0.8 V</td> </tr> </table> <p>Refer together with the checking method of the driver waveform because there is an explanation outside the column.</p> <p>When a defect of the PCB has been confirmed, carry out the following remedy.</p> <p>(1) Check whether the driver circuit fuse has blown by the tester, etc. When the fuse has blown, after replacement, check again by this procedure, and check that it has recovered. (Refer to Appendix 6 for the installation position of the fuse.)</p> <p>(2) When it has not recovered by the remedy in (1), replace the PCB.</p>	Normal	Approx. -0.8 V to -1.3 V	Abnormal	Approx. 0.0 V to -0.8 V
Normal	Approx. -0.8 V to -1.3 V				
Abnormal	Approx. 0.0 V to -0.8 V				
6	Connect the motor power line, etc. to restart an operation.				

(Checking method of driver waveform)

The following shows the driver waveforms when normal and when abnormal. Refer to them when a problem arises by the tester.

The checking methods differ slightly according to the PCB and PCB version number.

Take sufficient care about electric shocks because there is a high-voltage (300 VDC) section in each connector and its surroundings.

- (1) Set OFF the AC power. (Only version A20B-1003-0010 10B and after)
- (2) Set the setting of setting jumper S5 to the OFF side. (Only version A20B-1003-0010 10B and after)
- (3) Release the emergency stop, and input the rotation direction command (SFR, SRV).

At this time, set the speed command voltage (VCMD) at 0 V (0 rpm command).

- (4) Check the waveform between base and emitter of each transistor. Refer to section 6.4 step 5 for checking location.

For checking, be certain to use an insulated oscilloscope.

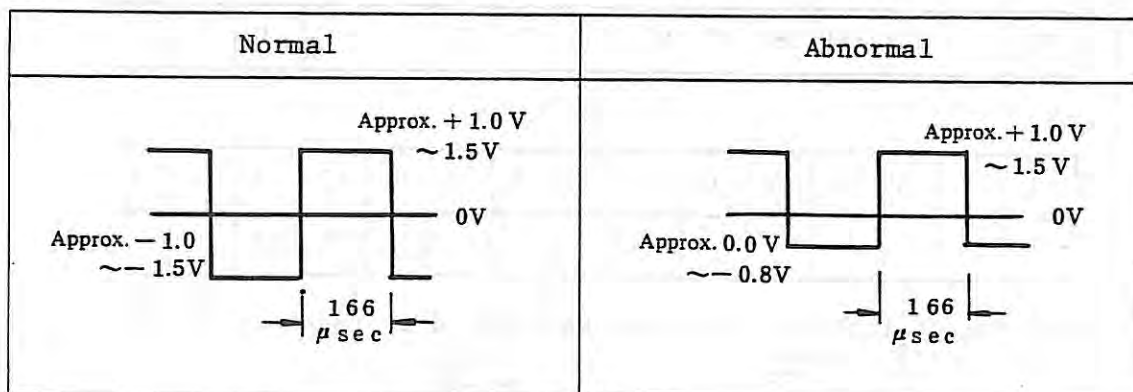

7. SPINDLE ORIENTATION CONTROL CIRCUIT

This chapter describes maintenance, installation, and adjustment when the orientation function is added to the spindle of CNC machine tool.

7.1 Configuration

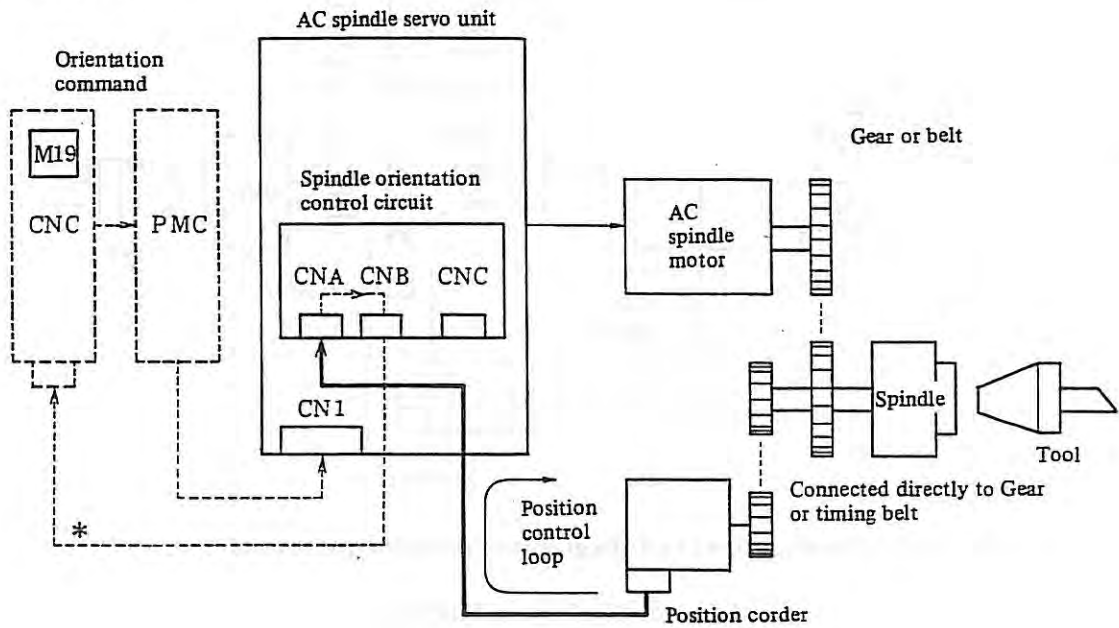

Fig. 7.1 (a) Configuration of spindle orientation using position coder (Internal stop position setting type)

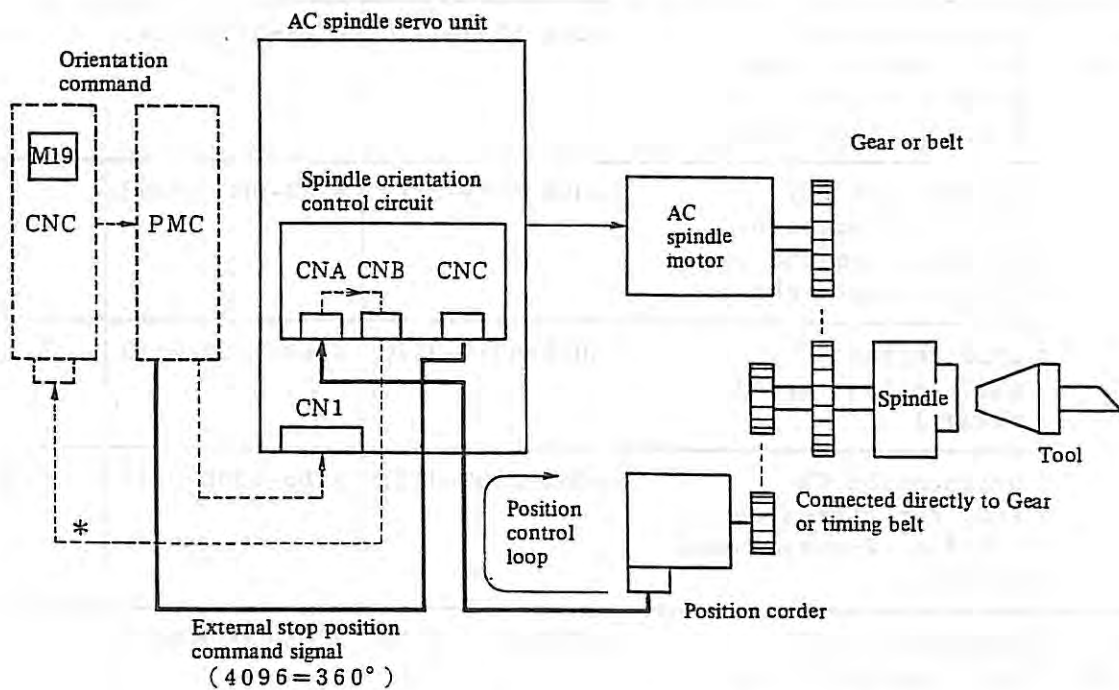

Fig. 7.1 (b) Configuration of spindle orientation using position coder (External stop position command type)

- Note 1) If a position coder has been mounted on a lathe, etc., it can be used.
 Note 2) Asterisked cable route is employed when the position coder for the lathe or synchronous feed in machining center is combined.

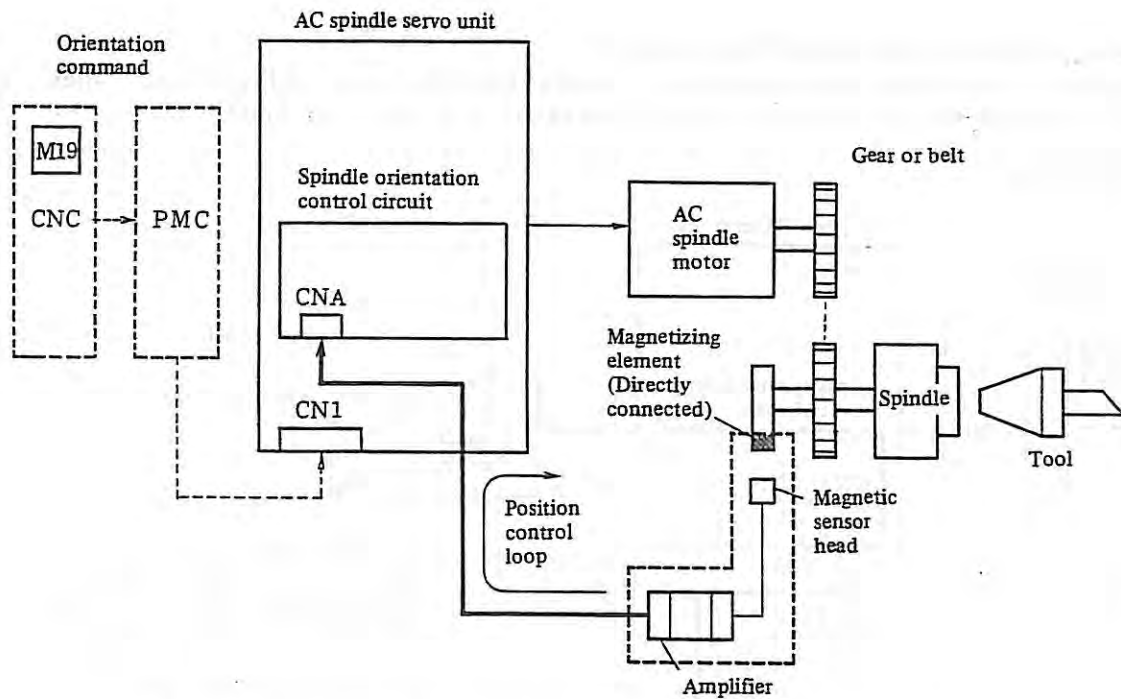

Fig. 7.1 (c) Configuration of spindle orientation using magnetic sensor

Table 7.1 Configuration elements

Application unit	Name	Order diagram number	PCB diagram number	Reference item
Models 1S - 3S	Orientation ARII (PC, internal stop position setting type, 2-stage speed change)	A06B-6059-J110	A20B-0008-0242	7.2.1
	Orientation BRII (PC, external stop position command type, 2-stage speed change)	A06B-6059-J111	A20B-0008-0243	7.2.1
	Orientation CR (MG, 2-stage speed change)	A06B-6059-J120	A16B-1300-0110	7.3.2
	Orientation GR (MG, for high-speed spindle, 2-stage speed change)	A06B-6059-J121	A16B-1300-0111	7.3.3
Models 6S - 26S	Orientation ASII (PC, internal stop position setting type, 2-stage speed change)	A06B-6059-J130	A20B-0008-0242	7.2.1
	Orientation BSII (PC, external stop position command type, 2-stage speed change)	A06B-6059-J131	A20B-0008-0243	7.2.1

Applica- tion unit	Name	Order diagram number	PCB diagram number	Reference item
Models 6S - 26S	Orientation AHS (PC, internal setting type, for high-speed spindle, 2-stage speed change)	A06B-6059-J132	A20B-0008-0244	7.2.1
	Orientation BHS (PC, external commad type, for high-speed spindle. 2-stage speed change)	A06B-6059-J133	A20B-0008-0245	7.2.1
	Orientation ES (PC, internal stop position setting type, 4-stage speed change)	A06B-6059-J134	A20B-1000-0462	7.2.2
	Orientation FS (PC, external stop position command type, 4-stage speed change)	A06B-6059-J135	A20B-1000-0463	7.2.2
	Orientation CSII (MG, 2-stage speed change)	A06B-6059-J140	A20B-0008-0032	7.3.2
	Orientation DSII (MG, 3-stage speed change)	A06B-6059-J142	A20B-0009-0521	7.3.4
	Orientation GSII (MG, for high-speed spindle, 2-stage speed change)	A06B-6059-J141	A20B-0008-0033	7.3.3

Note) PC: Position coder
MG: Magnetic sensor

7.2 Setting and Adjusting Spindle Orientation Control Circuit of Position Coder System

7.2.1 2-step spindle speed change or less

Application PCB diagram number A20B-0008-0242 (ARII : models 1S - 3S)
 (ASII : models 6S - 26S)
 A20B-0008-0243 (BRII : models 1S - 3S)
 (BSII : models 6S - 26S)
 A20B-0008-0244 (AHSII: models 6S - 26S)
 A20B-0008-0245 (BHSII: models 6S - 26S)

1) Display contents

The following display is done using LED.

Refer to Fig. 7.2.1 for the installation position.

LED No.	Symbol	Description
LED 1	ORIENTATION	Lights when orientation command (ORCM) is input.
LED 2	LOW	Lights when contact of gear HIGH/LOW switching signal (*CTH) is closed, and means that gear LOW has been selected.
LED 3	IN-POSITION OUT	Lights when orientation operation is completed and is within setting pulse of stop position, and indicates that the orientation end signal has been sent. The width setting of the stop position is performed by SH02.
LED 4	IN-POSITION ADJUST	Lights when spindle enters within 1 pulse width of orientation command position. Adjust the variable resistor RV3/RV5 for offset adjustment when the gear is HIGH or LOW, and adjust so that this LED lights.

2) Setting

Name	Contents	Setting
T1 - T5	Setting of power for position coder (+5 V)	Supply from unit ON side selection (Note)
		Supply from NC No mark side selection
T6 - T14	Type of position coder (Balanced type/ unbalanced type)	Balanced type T6-14 A side selection
		Unbalanced type T6-14 B side selection
SH01 - 03	Refer to article 3).	

Note) When supplied from the unit, the +5 V power supply will short circuit, so do not connect with the NC.

3) Setting SH01-03

"o" mark in table indicates short circuit; "x" mark indicates open.

3)-1 Setting SH01

No.	Setting contents		SH01								Remarks	
			1 16	2 15	3 14	4 13	5 12	6 11	7 10	8 9		
1	Setting of rotating direction in the first orientation after turning on the power switch.	CCW	o	x								Setting at shipment
		CW	x	o								
2	Setting of rotating direction in the second and subsequent orientation.	CCW direction only			x (o)							(Note)
		CW direction only			x x							(Note)
		Same as rotation direction			(o) x							Setting at shipment (Note)
3	Determined by position gain. Setting to clamp the orientation speed.	1				x	x					
		2/3				o	x					
		1/3					x	o				
4	Setting by rotation direction of spindle and rotation direction of position coder.	Same direction							o	x	Differs for each machine tool. Hunting occurs if this setting is inverted.	
		Opposite direction							x	o		

Note) Select CCW direction only when using the signal conversion circuit in chapter 11.

3)-2 Setting SH02

No.	Setting contents		SH01								Remarks
			1 16	2 15	3 14	4 13	5 12	6 11	7 10	8 9	
1	Setting of the in-position width when orientation end signals (ORAR1, 2) are output. (Note)	+2 pulses	o	o	o	o	o	o			1 pulse corresponds to 0.088°
		+4 pulses		o	o	o	o	o			
		+8 pulses			o	o	o	o			
		+16 pulses				o	o	o			
		+32 pulses					o	o			
		+64 pulses						o			
2	Setting by hysteresis of position coder	No compensation							x	x	Setting at shipment
		+1 pulse							o	x	
		-1 pulse								x	o

Note) The sending conditions of the orientation end signal C are when the AND condition of the following 3 signals are effected.
 C = (Angle position is located within the in-position width setting pulse)
 . x (Speed zero signal (SST) is turned on) x (Orientation command (ORCM) is turned on)

3)-3 Setting SH03

No.	Contents		SH03		Remarks
			1	2	
1	Setting according to the type of AC spindle servo unit.	DC	o	x	Setting at shipment
		AC	x	o	

Note) Setting by the user is not necessary.

4) Setting position switches (SW1, 2, 3)

Setting of stop position is performed by the digital switches SW1 - 3 which are the respective 16th divisions. Refer to Fig. 7.2.1 for the installation position of the digital switches.

Setting switch	Pulse number per 1 division	Angle per 1 division
SW1	$4096/16 = 256$ pulses	$22.5^\circ/\text{division}$
SW2	$256/16 = 16$ pulses	$1.4^\circ/\text{division}$
SW3	$16/16 = 1$ pulse	$0.088^\circ/\text{division}$

The spindle motor can be stopped at any position in one rotation in the unit of $1/4096 \times 360^\circ = 0.088^\circ$ by setting these switches in the order of SW1, SW2, SW3.

5) Adjustments

Refer to Fig. 7.2.1 for the installation position of each of the variable resistors RV1 - 6.

No.	Item	Name of variable resistor	Standard adjustment (Division)	Measuring point	Description
1	Speed feedback voltage offset	RV1	5	TSA2 CH14 (TSA2)	Adjust RV1 until TSA2 voltage becomes 0 ± 1 mV.
2	Gear HIGH position gain	RV2	3 - 4	Spindle motion or CH14	Set the gain to the maximum within a range where the spindle does not overshoot.
3	Gear HIGH offset	RV3	About 5	LED4 (ADJUST)	Adjust RV3 until LED4 lights or flickers.
4	Gear LOW position gain	RV4	3 - 6	Spindle motion or CH14	Set the gain to the maximum within a range where the spindle does not overshoot.
5	Gear LOW offset	RV5	About 5	LED4 (ADJUST)	Adjust RV5 until LED4 lights or flickers.
6	Speed loop gain	RV6AC	7	CH14 (TSA2)	Make sure that motor is not hunting. The rigidity increases during stop by turning these RV clock-wise.

Note) It is not necessary to adjust RV6DC.

Fig. 7.2.1 Location of test pins, variable resistors, jumpers, and light-emitting diodes (LED) (PCB A20B-0008-0242 - 0245)

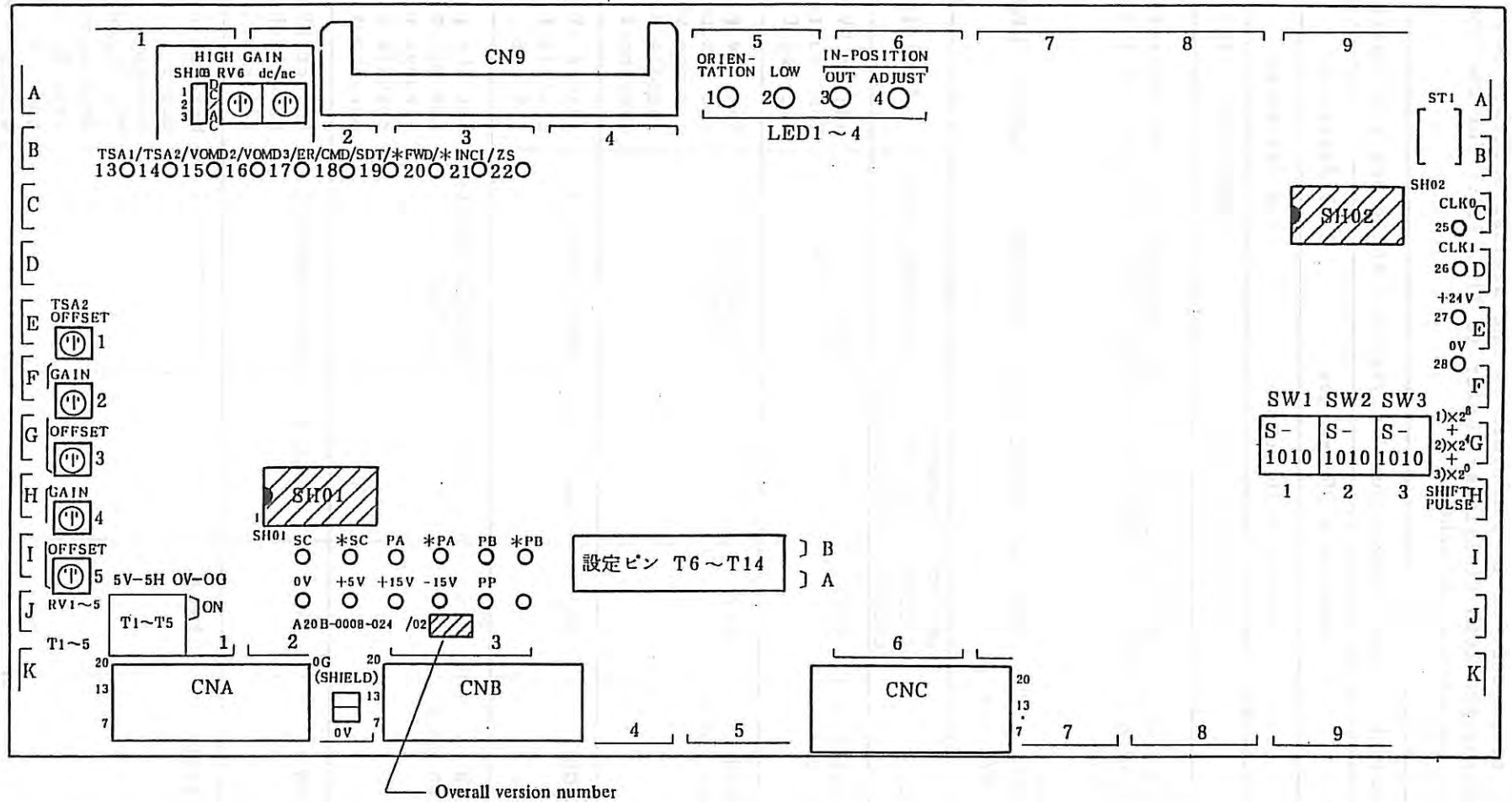

7.2.2 When spindle 3, 4-stage speed change

Application PCB diagram number A20B-100-0462 (ES: Models 6S - 26S)
 A20B-100-0463 (FS: Models 6S - 26S)

1) Display contents

The following is displayed using the light-emitting diode (LED).

Refer to Fig. 7.2.2 for the installation position.

LED No.	Symbol	Contents
LED 1	ORIENTATION	Lights when orientation command (ORCM) is input.
LED 2	CTH	Lights when contact of gear HIGH/LOW switching signal (*CTH) is closed. (Note)
LED 3	CTM	Lights when contact of gear MEDIUM signal (CTM) is closed. (Note)
LED 4	IN-POSITION OUT	Lights when orientation operation is completed and is within setting pulse of stop position, and indicates that the orientation end signal has been sent. The width setting of the stop position is performed by SH02.
LED 5	IN-POSITION ADJUST	Lights when spindle enters within <u>+2</u> pulses width of orientation command position. Adjust the variable resistor RV3 for offset adjustment when the orientation is completed, and adjust so that this LED lights.

Note) Corresponding to each speed change stage, the contact signal is controlled as follows.

Selection of speed change stage	Contact of *CTH signal	Contact of CTM signal	LED2	LED3
High-speed (HIGH)	OFF (Open)	OFF (Open)	OFF	OFF
Medium high-speed (MEDIUM-HIGH)	OFF (Open)	ON (Closed)	OFF	ON
Medium low-speed (MEDIUM-LOW)	ON (Closed)	OFF (open)	ON	OFF
Low-speed (LOW)	ON (closed)	ON (closed)	ON	ON

2) Setting jumper

Name	Contents	Setting
	Setting of power for position coder (+5 V)	Supply from unit ON side selection (Note)
		Supply from NC No mark side selection
T1-T9	Type of position coder (Balanced type/unbalanced type)	Balanced type T1-9 A side selection
		Unbalanced type T1-9 B side selection
SH01-03	Refer to article 3).	

Note) When supplied from the unit, the +5 V power supply will short circuit, so do not connect with the NC.

3) Setting SH01 - 03

"o" mark in table indicates short circuit; "x" mark indicates open.

3)-1 Setting SH01

No.	Setting contents	SH01								Remarks	
		1 16	2 15	3 14	4 13	5 12	6 11	7 10	8 9		
1	Setting of rotating direction in the first orientation after turning on the power switch.	CCW	o	x							Setting at shipment
		CW	x	o							
2	Setting of rotating direction in the second and subsequent orientation.	CCW direction only			x (o)						(Note)
		CW direction only			x	x					(Note)
		Same as rotation direction			(o)	x					
3	Determined by position gain. Setting to clamp the orientation speed.	1				x	x				
		2/3				o	x				
		1/3					x	o			

No.	Setting contents		SH01								Remarks
			1	2	3	4	5	6	7	8	
			16	15	14	13	12	11	10	9	
4	Setting by rotation direction of spindle and rotation direction of position coder.	Same direction							o	x	Differs for each machine tool. Hunting occurs if this setting is inverted.
		Opposite direction							x	o	

Note) Select CCW direction only when using the signal conversion circuit in chapter 11.

3)-2 Setting SH02

No.	Setting contents		SH01								Remarks
			1	2	3	4	5	6	7	8	
			16	15	14	13	12	11	10	9	
1	Setting of the in-position width when orientation end signals (ORAR1, 2) are output.	+2 pulses	o	o	o	o	o	o			1 pulse corresponds to 0.088°
		+4 pulses		o	o	o	o	o			
		+8 pulses			o	o	o	o			
		+16 pulses				o	o	o			
		+32 pulses					o	o			
		+64 pulses						o			
2	Setting by hysteresis of position coder	No compensation							x	x	Setting at shipment
		+1 pulse							o	x	
		-1 pulse								x	o

Note) The sending conditions of the orientation end signal C are when the AND condition of the following 3 signals are effected.

C = (Angle position is located within the in-position width setting pulse)
 x (Speed zero signal (SST) is turned on) x (Orientation command (ORCM) is turned on)

3)-3 Setting SH03

No.	Contents	SH03		Remarks	
		1	2		
1	Setting according to the type of AC spindle servo unit.	DC	o	x	Setting at shipment
		AC	x	o	

Note) Setting by the user is not necessary.

4) Setting stop position

Setting of stop position is performed by the digital switches SW1 - 3 which are the respective 16th divisions. Refer to Fig. 7.2.2 for the installation position of the digital switches.

Setting switch	Pulse number per 1 division	Angle per 1 division
SW1	$4096/16 = 256$ pulses	$22.5^\circ/1$ division
SW2	$256/16 = 16$ pulses	$1.4^\circ/1$ division
SW3	$16/16 = 1$ pulse	$0.088^\circ/1$ division

The spindle motor can be stopped at any position in one rotation in the unit of $1/4096 \times 360^\circ = 0.088^\circ$ by setting these switches in the order of SW1, SW2, and SW3.

5) Adjustment

Refer to Fig. 7.2.2 for the installation position of each variable resistor RV1 - 8.

No.	Item	Adjustment location	Standard adjustment	Measurement location	Contents
1	Speed loop gain	RV1AC	7th division		Check that it is not oscillating. If turned to the right, rigidity at stop increases.
2	Offset of speed feedback voltage	RV2	5th division	TSA2	Adjust so that it becomes 0 mV \pm 1 mV at spindle stop.
3	Fine adjustment of position	RV3	5th division	LED5	Adjust so that LED5 lights at gear HIGH.

No.	Item	Adjustment location	Standard adjustment	Measurement location	Contents
4	Position gain at gear LOW *CTH:ON, CTM:ON	RV4	2nd division	Spindle operation or TSA2	Set so that gain becomes highest in range that spindle does not overshoot.
5	Position gain at gear M.-LOW *CTH:ON, CTM:OFF	RV5	2nd division	Spindle operation or TSA2	Set so that gain becomes highest in range that spindle does not overshoot.
6	Position gain at M.-HIGH gear *CTH:OFF, CTH:ON	RV6	2nd division	Spindle operation or TSA2	Set so that gain becomes highest in range that spindle does not overshoot.
7	Position gain at HIGH gear *CTH:OFF, CTH:OFF	RV7	2nd division	Spindle operation or TSA2	Set so that gain becomes highest in range that spindle does not overshoot.
8	Offset adjustment of ER voltage	RV8	0 \pm 1 mV	ER	Adjustment at shipment (Refer to precautions below.)
		<p>Note 1) Set SW1 to 8th division; SW2 and SW3 to 0th division.</p> <p>Note 2) Set setting jumpers T2, 3, 5, and 6 OFF.</p> <p>Note 3) After orientation command ON motor rotation, perform the above adjustment.</p>			

Note) It is not necessary to adjust RV1DC.

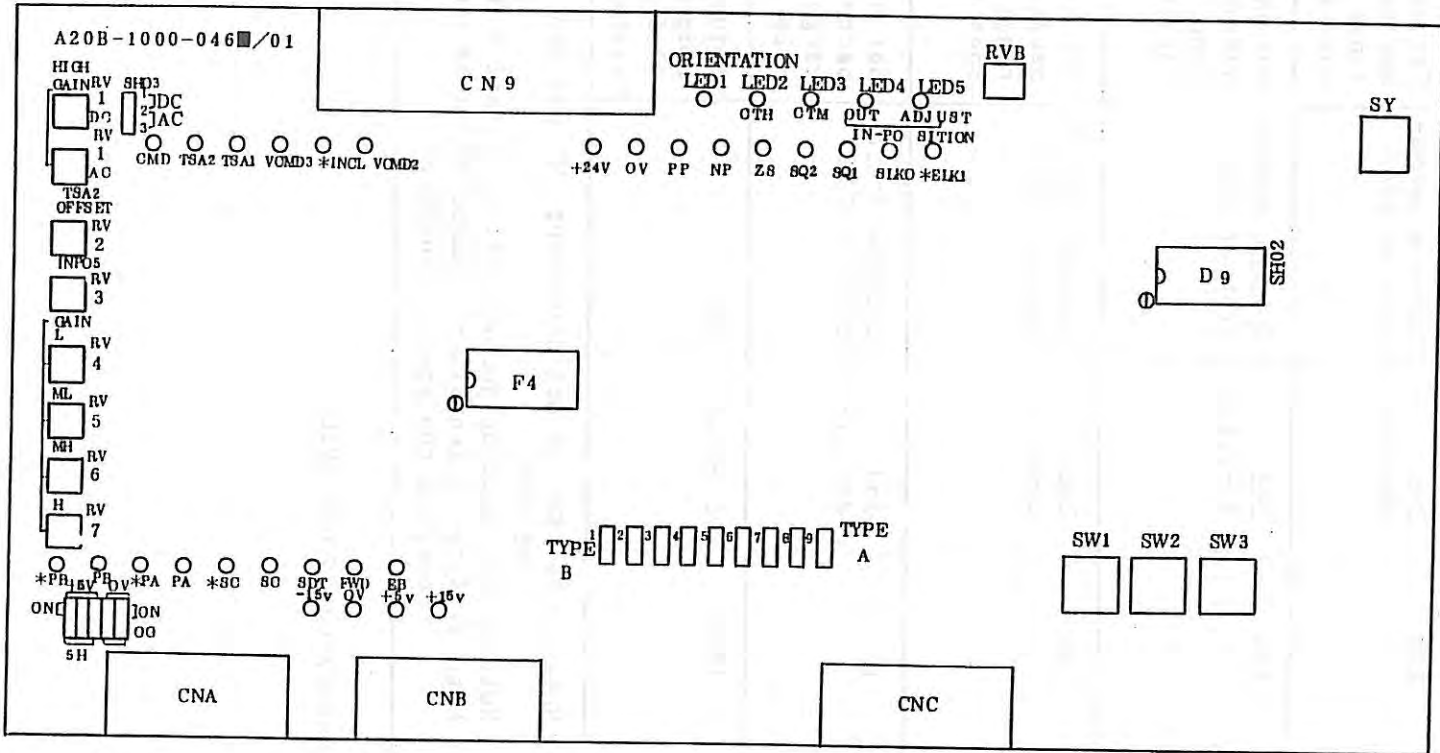

Fig. 7.2.2 Installation position of LEDs, setting jumpers, variable resistors, and check terminals PCB diagram number A20B-1000-0462-0463

7.3 Adjusting Spindle Orientation Control Circuit of Magnetic Sensor Type

7.3.1 Mounting magnetizing element and magnetic sensor

When mounting the magnetizing element in the spindle of the machine tool, because there is a polarity between the magnetic sensors, the mounting direction differs according to the configuration (belt, gear coupling, etc.) of the spindle.

When the magnetizing element is rotated by the motor forward rotation command (SFR: ON, VCMD: Forward), arrange the reference hole and stop position verify division to face as shown in the diagram below, and arrange the pin hole of the magnetic sensor to be as in the diagram below. (The direction of the pin hole differs in plate type and ring type.)

Set the gap of the magnetizing element and sensor head so that the gap minimum value ΔL becomes $\Delta L = 1.5 \pm 0.5$ mm.

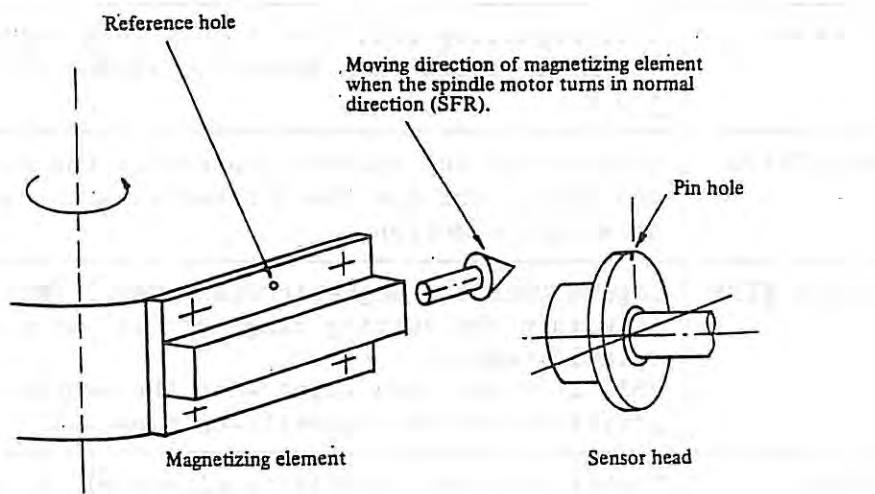

(a) Plate type

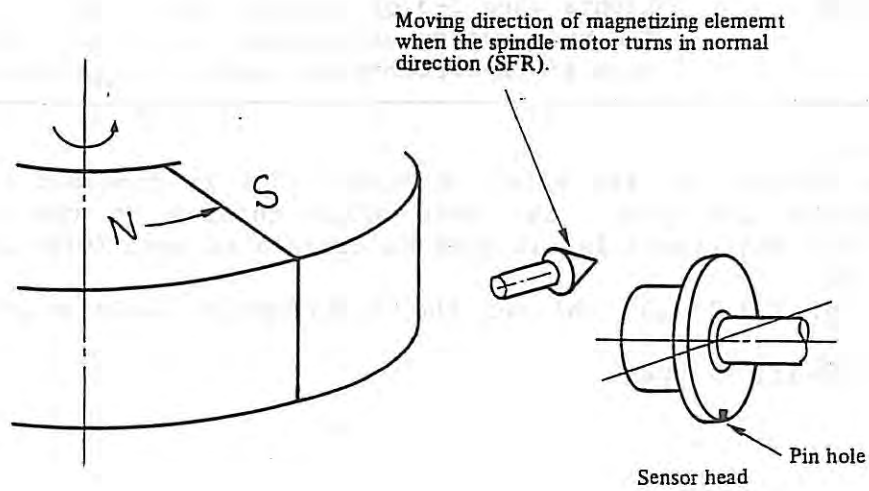

(b) Ring type

Fig. 7.3.1 Mounting magnetizing element

7.3.2 When spindle 2-stage speed change

Application PCB diagram number A16B-1300-0110 (CR: Models 1S - 3S)
A20B-0008-0032 (CSII: Models 6S - 26S)

1) LED

The following is displayed using the light-emitting diode (LED).
Refer to Fig. 7.3.2 (a), (b) for the installation position.

LED display contents		
LED	Display contents	Description
1	ORIENTATION	Lights when orientation command (ORCM) is input.
2	LOW	Lights when contact of gear HIGH/LOW switching signal (*CTH) is closed.
3	MS PEAK LEVEL	This adjusting indicator lights when the peak value of the magnetic flux detection signal (MS) exceeds <u>+10 V</u> .
4	SLOWDOWN PERIOD	Lights when the spindle approaches the stop position and enters the low speed rotation area during spindle orientation motion.
5	IN POSITION FINE	Lights when the magnetic flux signal (output) value is within the setting range of 0.1° as a converted spindle angle. This LED5 may also light when the sensor is not positioned on the magnetizing element.
6	IN-POSITION	Lights when the spindle is within $\pm 1^\circ$ of the aimed adjusting position after completion of spindle orientation. The spindle orientation end signal (ORAR) is sent when this LED is lighting in a mode other than TEST mode.
7	TEST MODE	Lights when 2-3 of setting jumper SH01 is turned ON. The orientation end signal is not sent in this mode even if the orientation motion is executed.

2) Setting pin

Select the settings by the user. However, SH01 is provided for adjustment and testing at the site. Set this after turning on the power supply. Further, after adjustment is finished be certain to open (OFF) and check that LED7 goes out.

Refer to Fig. 7.3.2 (a), (b) for the installation position of the jumpers SH01 - 05.

o: Short circuit, x: open

Table 7.3.2 (a) Setting jumpers (SH)

Jumpers (The double frame indicates standard setting)						
Setting (Note 1)			Function	Remarks		
SH	1-2	2-3				
01		o	Sets the test mode. (Note 2)	Set for adjustment only.		
02	o	x	Rotates the motor shaft clockwise when the orientation command is given before operating the spindle after turning on the power.	SH03 setting takes precedence of SH02. This is effective only when 1-2 pins of SH03 are shorted.		
	<table border="1"><tr><td>x</td><td>o</td></tr></table>	x	o			Rotates the motor shaft counter-clockwise when the orientation command is given before operating the spindle after turning on the power.
x	o					
03	<table border="1"><tr><td>o</td><td>x</td></tr></table>	o	x		Orients in the direction of the spindle rotation just before the orientation command was given.	SH02 setting becomes effective.
	o	x				
	x	o	Always orients the spindle counter-clockwise.			
x	x	Always orients the spindle clockwise.				
04	x	x	Sets the initial orientation speed of the spindle: Approx. $60 \times (\text{spindle position loop gain, sec}^{-1})$ rpm	Since the position loop gain of spindle is 5 sec^{-1} in general, the initial speed is about 300 rpm without limitation.		
	<table border="1"><tr><td>o</td><td>x</td></tr></table>	o	x			Limits the initial orientation speed to 1/3.
	o	x				
x	o	Limits the initial orientation speed to 2/3.				
05	o	x	For DC spindle servo unit.	It is not necessary to set by user.		
	<table border="1"><tr><td>x</td><td>o</td></tr></table>	x	o			For AC spindle servo unit.
x	o					

Note 1) indicates standard settings.

Note 2) Use of the TEST MODE

- (1) Turn on the spindle orientation command (ORCM).
- (2) Spindle orientation end signals (ORAR) are not sent.
- (3) The spindle turns at the initial orientation speed, while the SW1 (INITIALIZING BUTTON) is being pressed and the spindle stops at the specific position when SW1 is released.
- (4) Red LED7 lights in this mode.

3) Setting variable resistors

Adjust the variable resistor as shown in the following table before starting adjustments.

Asterisked items are readjusted during adjustment procedure described later. Set these items also as the preliminary setting.

Refer to Fig. 7.3.2 (a), (b) for the installation position of each variable resistor RV1 - 12.

Adjusting variable resistor

Orientation	Variable resistor											
	RV1 *	RV2 *	RV3	RV4	RV5	RV6 *	RV7 *	RV8	RV9 *	RV10 *	RV11 *	RV12 AC
CSII	5.0	6.0	See (a)	See (a)	See (b)	2.0	5.0	See (c)	2.0	5.0	5.0	7.0
CR		5.0										

It is not necessary to set RV12DC.

a) RV3, RV4

Follow the distance H between the rotational center of magnetic element and center of sensor head surface.

H (mm)	60 to 65	To 70	To 75	To 80	To 85	To 90	To 95	To 100	To 105	To 110
Division	7.0	6.0	5.0	4.0	3.0	2.5	2.0	1.5	1.0	0.5

b) RV5

Follow the number of HIGH spindle rotation (Nhm) at rated speed.

Nhm (rpm)	2000 to 2200	To 2500	To 2700	To 3100	To 3500	To 4000	To 4500	To 5000	To 5500	To 6000
Division	7.5	6.5	5.5	4.5	3.5	2.5	2.0	1.5	1.0	0.5

c) RV8

Follow the gear ratio Rh/1 of HIGH/LOW gear.

Rh/1	To 2.0	To 2.2	To 2.5	To 2.8	To 3.2	To 3.7	To 4.4	To 5.3	To 6.0	To 7.0
Division	2.0	3.0	4.0	5.0	6.0	7.0	8.0	9.0	9.5	10.0

4) Adjusting variable resistors

Adjust RV1 - 12 according to the following table. Adjust the offset and gain of spindle control circuit PCB before adjusting the orientation circuit. When RV12 and RV13 of the spindle control circuit PCB are changed, the stop position may be deviated.

Set the test mode for the following adjustments by shorting SH01 pins.

Table 7.3.2 (b) Adjusting variable resistors

No.	Item	Adjustment location	Measurement location	Contents
1	Speed feedback voltage offset. TS OFFSET	RV1	CH16(TSA2)	Adjust so that voltage of TSA2 becomes 0 \pm 1 mV.
2	MS signal amplitude value. MS PEAK LEVEL	RV2	LED3	Set to the position where LED3 starts flickering by continuously pressing SW1 (INITIALIZING BUTTON).
3	Slowdown speed reference. SLOWDOWN REFERANCE	RV3		Refer to 7.3.2, 3) a).
4	AMS signal amplitude value. AMS PEAK LEVEL	RV4		Refer to 7.3.2, 3) a).
5	Slowdown time in gear high mode. SLOWDOWN TIME IN HIGH MODE	RV5	LED4	Set the orientation operation by pressing SW1 in the gear high state (*CTH:OFF). LED4 should clearly light momentarily immediately before stop.
6	Position gain in gear high mode. GAIN(H)	RV6	Spindle operation or CH16	Set the orientation operation by pressing SW1, and set the highest gain in the range that the spindle does not overshoot at stop.
7	Adjustment of stop position in gear high mode. IN-POSITION (H)	RV7	LED5, LED6	Set the orientation operation by pressing SW1, and adjust so that LED5 lights while LED6 is lit.
8	Slowdown time in gear low mode. SLOWDOWN TIME IN LOW MODE	RV8	LED4	Set the orientation operation by pressing SW1 in the gear low state (*CTH: ON). LED4 should clearly light momentarily immediately before stop.

No.	Item	Adjustment location	Measurement location	Contents
9	Position gain in gear low mode. GAIN(L)	RV9	Spindle operation or CH16	Set the orientation by pressing SW1, and set the highest gain in the range that the spindle does not overshoot at stop.
10	Adjustment of stop position in gear low mode. IN-POSITION(L)	RV10	LED5, LED6	Set the orientation operation by pressing SW1, and adjust so that LED5 lights while LED6 is lit.
11	Spindle stop position shift. POSITION SHIFT	RV11	Spindle operation	The stop position can be finely adjusted within a range of $\pm 1^\circ$ at the spindle angle.
12	High gain. HIGH GAIN AC	RV12AC	Spindle operation	Check that it does not oscillate. If turned to the right, the rigidity increases.

* It is not necessary to adjust RV12DC.

After adjustments are finished, release the test mode, and check that LED7 goes out.

Fig. 7.3.2 (a) Location of test pins, variable resistors, jumpers and LEDs

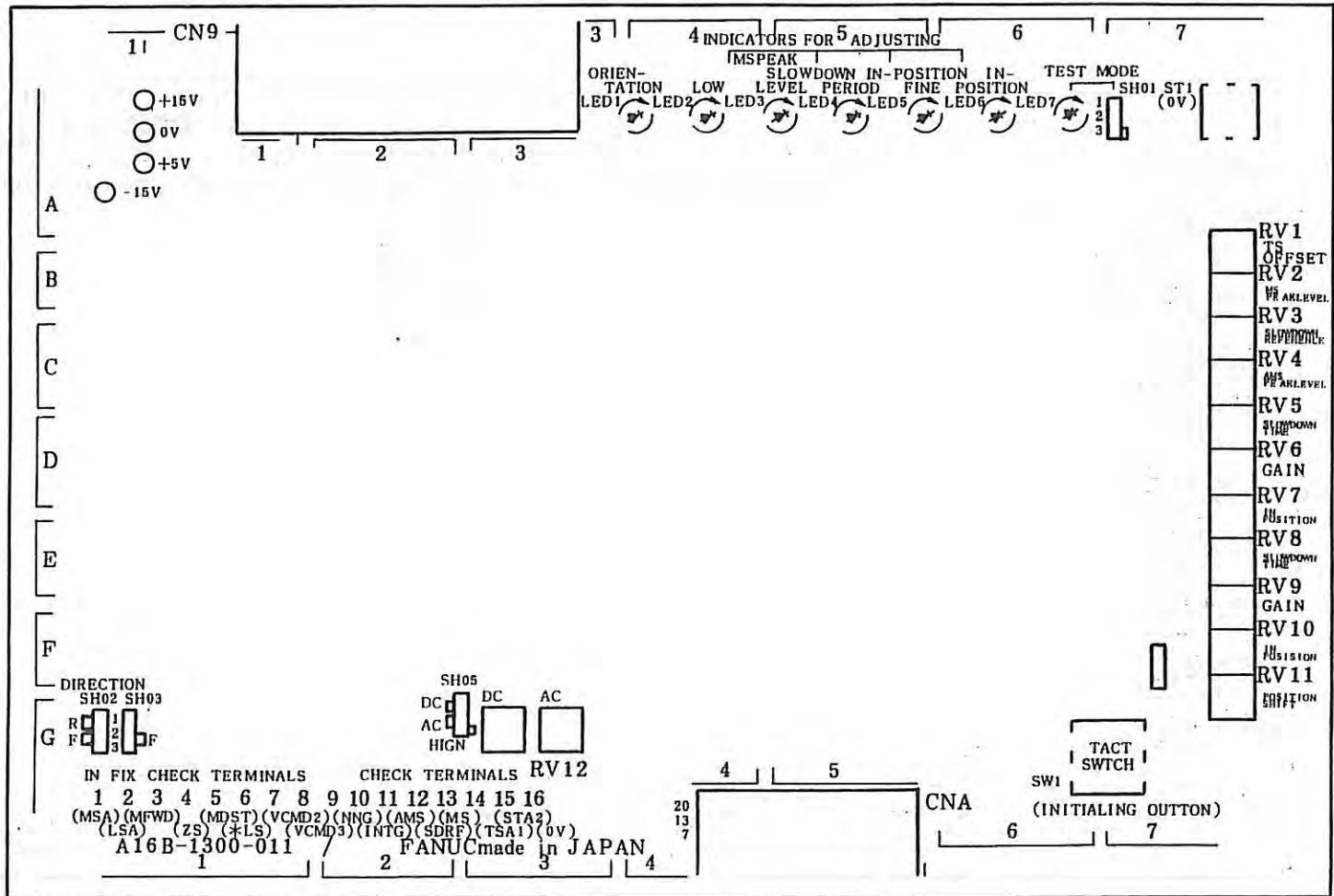

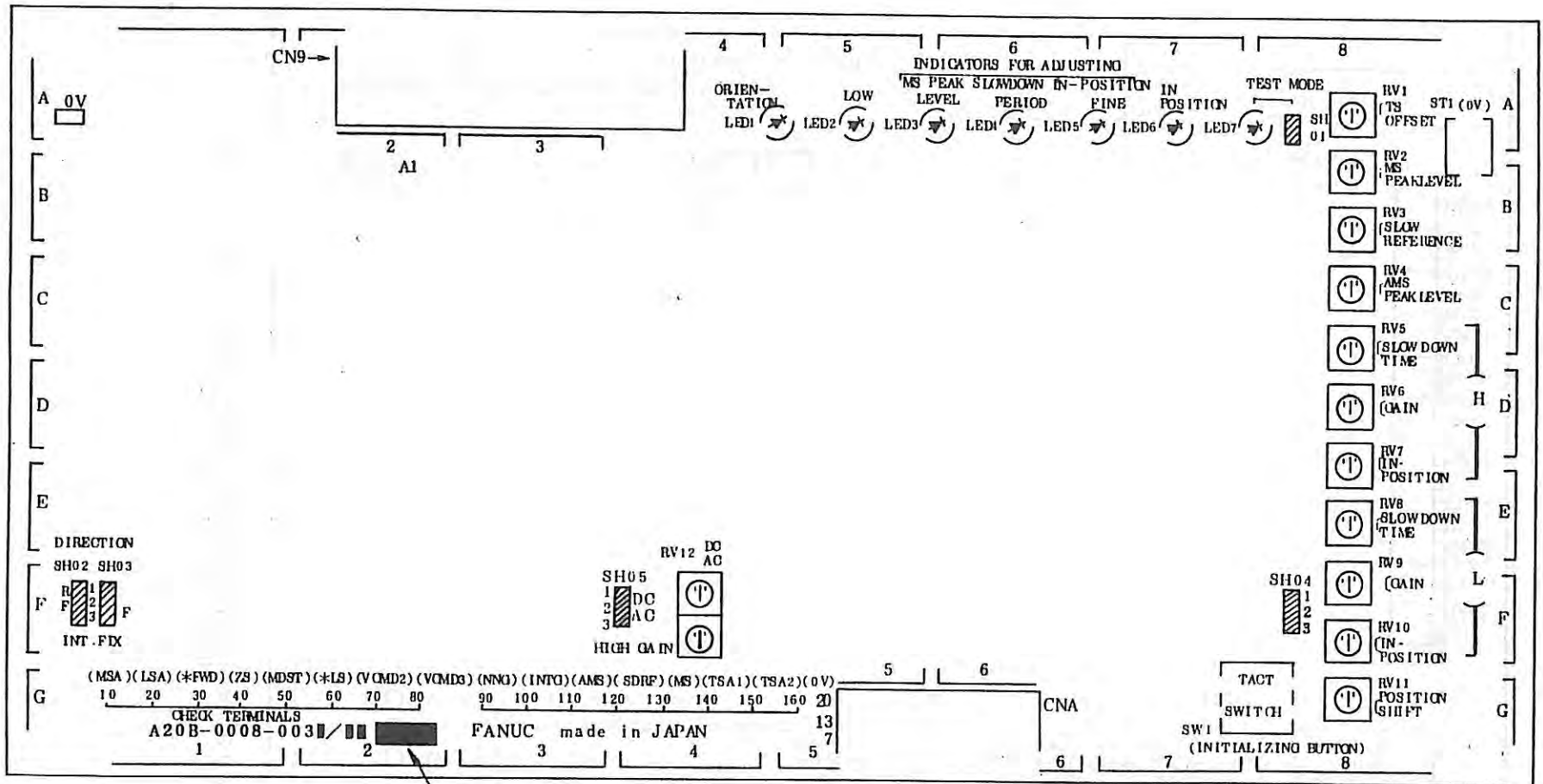

Fig. 7.3.2 (b) Location of test pins, variable resistor, jumpers and LEDs
 (PCB: A20B-0008-0032,-0033)

7.3.3 When spindle less than 2-stage speed change/high-speed spindle

Application PCB diagram number A16B-1300-0111 (GR: Models 1S - 3S)
 A20B-0008-0033 (GSII: Models 6S - 26S)

- 1) Display contents
 Refer to item 7.3.2 (1).
 Refer to Fig. 7.3.2 (a), (b) for the installation position.
- 2) Setting jumper
 Refer to item 7.3.2 (2).
 Refer to Fig. 7.3.2 (a), (b) for the installation position.
- 3) Setting variable resistor
 First adjust, and set the division of the variable resistor as shown in the following table. Items with * mark in the table are readjusted by later described adjustment items, but apply as settings at the preparation stage. Refer to Fig. 7.3.2 (a), (b) for the installation position of each variable resistor RV1 - 12.

Setting and preparation of variable resistor

Variable resistor name		RV1 *	RV2 *	RV3	RV4	RV5	RV6 *	RV7 *	RV8	RV9 *	RV10 *	RV11 *	RV12 AC
Division	GR	5.0	6.0	a)	a)	b)	5.0	5.0	c)	5.0	5.0	5.0	8.0
	GSII	5.0	6.0	a)	a)	b)	2.0	5.0	c)	2.0	5.0	5.0	7.0

Note) It is not necessary to set RV12DC.

a) Setting RV3, RV4

Set RV3 and RV4 according to the distance between the rotation center of the magnetizing element and the center of the sensor head surface.

H (mm)	40-45	- 50	- 55	- 60	- 65	- 70	- 80	- 90	- 100	- 110
Division	9.5	7.0	5.0	4.0	3.0	2.5	2.0	1.5	1.0	1.0

b) Setting RV5

Set RV5 according to the speed NHM in high gear mode at the rating rotation of the spindle motor.

N HM (rpm)	6000 -6500	-7000	-7500	-8000	-8500	-9000	-9500	-10000	-11000	-12000
Division	6.0	5.0	4.5	4.0	3.5	3.0	2.5	2.5	2.0	1.0

c) Setting RV8

Set RV8 according to speed change ratio RH/L of gear high/low modes.

R H/L	- 2.2	- 2.5	- 2.8	- 3.2	- 3.7	- 4.5	- 5.0	- 6.0	- 7.0
Division	2.0	3.0	4.0	5.0	6.0	7.0	8.0	8.0	9.0

- 4) Adjusting variable resistor
Refer to item 7.3.2 (4).

7.3.4 When spindle 3-stage speed change

Application PCB diagram number A20B-0009-0521 (DSII: Models 6S - 26S)
Take care at application because there are the following restrictions for the spindle maximum speed range for each speed change stage.

	Spindle maximum speed range
High-speed (HIGH)	4000 - 8000 rpm
Medium-speed (MEDIUM)	1000 - 2000 rpm
Low-speed (LOW)	250 - 677 rpm

1) Display contents

Displays the following by using a light-emitting diode (LED).
Refer to Fig. 7.3.4 for the installation position.

LED	Display contents	Description
LED1	ORIENTATION	Lights when orientation command (ORCM) is input.
LED2H	GEAR/CLUTCH	Lights when gear HIGH is selected.
LED2M		Lights when gear MEDIUM is selected.
LED2L		Lights when gear LOW is selected.
LED3	MS PEAK LEVEL	Lights only when peak value of the magnetic detection signal (MS) of one adjustment indicator (INDICATOR FOR ADJUSTING) is exceeding the range of ± 10 V.
LED4	SLOWDOWN PERIOD	Lights if the spindle position approaches the stop position during spindle orientation operation, and enters the low speed rotation area.
LED5	IN-POSITION FINE	Lights when the value of magnetic detection signal (output) is inside the range of 0.1° by converting the spindle angle. However, there are cases it lights even when the sensor is not in the range of the magnetizing element.
LED6	IN-POSITION	Lights when spindle orientation is complete, and spindle is inside range of target position $\pm 1^\circ$. In other than TEST MODE, the spindle orientation ready signal (ORAR) is sent when this LED is lit.
LED7	TEST MODE	Lights when 2-3 of setting jumper SH01 are set ON. In this mode, the orientation ready signal is not sent even if the orientation operation is performed.

2) Setting jumper

Refer to item 7.3.2 (2).

Refer to Fig. 7.3.4 for installation position.

3) Setting variable resistors RV3, RV4

Set RV3 and RV4 according to the distance between the rotation center of the magnetizing element and the center of the sensor head surface.

H (mm)	- 50	- 60	- 70	- 80	- 90	- 100	- 110	- 120
Division	9.5	6.5	4.5	3.0	2.5	1.5	1.0	0.5

4) Adjusting variable resistor

Adjust RV1 - 15 according to the following table. Adjust the orientation circuit after the adjustment of each offset gain, etc. of the spindle control circuit PCB is finished. If the adjustment on the spindle control circuit is changed, there are cases when the stop position slips.

Further, the following adjustments are carried out in the test mode by shorting SH01.

Refer to Fig. 7.3.4 for the installation position of each variable resistor RV1 - 15.

No.	Item	Adjustment location	Measurement location	Contents
1	Speed feedback voltage offset. TS OFFSET	RV1	CH15(TSA2)	Adjust so that voltage of TSA2 becomes 0 \pm 1 mV.
2	MS signal amplitude value. MS PEAK LEVEL	RV2	LED3	Set to the position where LED3 starts flickering by continuously pressing SW1 (INITIALIZING BUTTON).
3	Slowdown speed reference. SLOWDOWN REFERENCE	RV3		Refer to 7.3.4 3).
4	AMS signal amplitude value. AMS PEAK LEVEL	RV4		Refer to 7.3.4 3).
5	Slowdown time in gear high mode. SLOWDOWN TIME IN HIGH MODE	RV5	LED4	Set the orientation operation by pressing SW1 in the gear high state (*CTH: OFF). LED4 should clearly light momentarily immediately before stop.
6	Position gain in gear low mode. GAIN (H)	RV6	Spindle operation or CH15	Set the orientation operation by pressing SW1, and set the highest gain in the range that the spindle does not overshoot at stop.
7	Adjustment of stop position in gear high mode. IN-POSITION (H)	RV7	LED5, LED6	Set the orientation operation by pressing SW1, and adjust so that LED5 lights while LED6 is lit.

No.	Item	Adjustment location	Measurement location	Contents
8	Slowdown time in gear low mode. SLOWDOWN TIME IN LOW MODE	RV8	LED4	Set the orientation operation by pressing SW1 in the gear low state (*CTH: ON). LED4 should clearly light momentarily immediately before stop.
9	Position gain in gear low mode. GAIN (L)	RV9	Spindle operation or CH15	Set the orientation operation by pressing SW1, and set the highest gain in the range that the spindle does not overshoot at stop.
10	Adjustment of stop position in gear low mode. IN-POSITION (L)	RV10	LED5, LED6	Set the orientation operation by pressing SW1, and adjust so that LED5 lights while LED6 is lit.
11	Slowdown time in gear medium mode. SLOWDOWN TIME IN MEDIUM MODE	RV12	LED4	Set the orientation operation by pressing SW1 in the gear medium state. LED4 should clearly light momentarily immediately before stop.
12	Position gain in gear medium mode. GAIN (M)	RV13	Spindle operation or CH15	Set the orientation operation by pressing SW1, and set the highest gain in the range that the spindle does not overshoot at stop.
13	Adjustment of stop position in gear medium mode. IN-POSITION (M)	RV14	LED5, LED6	Set the orientation operation by pressing SW1, and adjust so that LED5 lights while LED6 is lit.
14	Spindle stop position shift POSITION SHIFT	RV11	Spindle operation or CH15	The stop position can be finely adjusted within a range of $\pm 1^\circ$ at the spindle angle.
15	High gain. HIGH GAIN AC	RV15AC	Spindle operation or CH15	Check that it does not oscillate. If turned to the right, the rigidity increases.

Note) It is not necessary to adjust RV15DC.

After adjustments are finished, release the test mode, and check that LED7 goes out.

7.3.5 Checking method of spindle system position loop gain

The spindle position loop gain can be checked according to the following procedure.

Check it after adjusting the spindle orientation control circuit.

Item	Procedure
1	Set to TEST mode (LED7 ON) after shorting between 2 - 3 setting SH01 terminals.
2	Release the restrictions on orientation speed by opening 1 - 2 and 2 - 3 setting SH04 terminals.
3	Measure the rotation speed $N_{S(H)}$, $N_{S(L)}$, (rpm) when SW1 (initializing button) is ON, for spindle gear HIGH (*CTH: OFF) and spindle gear LOW (*CTH: ON) respectively.
4	<p>The spindle system position loop gain can be obtained by the following formula:</p> $K_{P(H \text{ or } L)} \approx N_{S(H \text{ or } L)} \div 55(\text{sec}^{-1})$ <p>Where,</p> <p>$K_{P(H)}$ is the position loop gain at gear HIGH, and $K_{P(L)}$ is the position loop gain at gear LOW.</p>

Fig. 7.3.4 Installation position of LEDs, setting jumpers, variable resistor, and check terminals PCB diagram number A20B-0009-0521

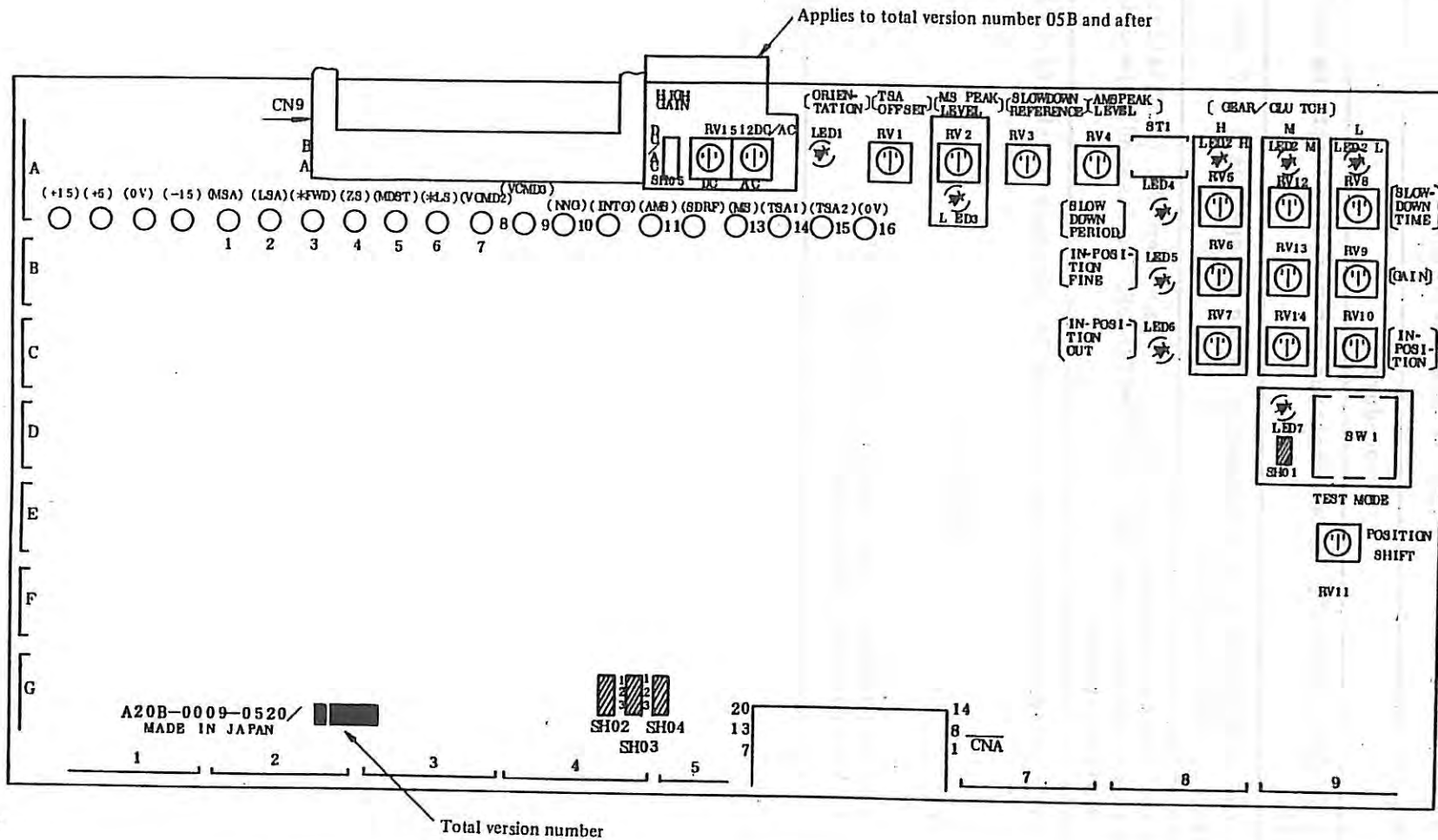

8. SPINDLE SWITCHING CONTROL CIRCUIT

This describes the maintenance when the spindle switching control circuit is added to control by switching 2 motor units to the AC spindle servo unit by 1 unit.

The spindle switching control circuit applies to models 6S - 26S.

Refer to chapter 5 for the contents of the parameter.

Note 1) Use the unit in the vertical direction when installing because the main spindle switching control circuit uses a mercury relay.

Note 2) Regarding the electromagnetic contactor to switch the motor power line, take the interlock so that it is not mutually and simultaneously set ON.

8.1 Configuration

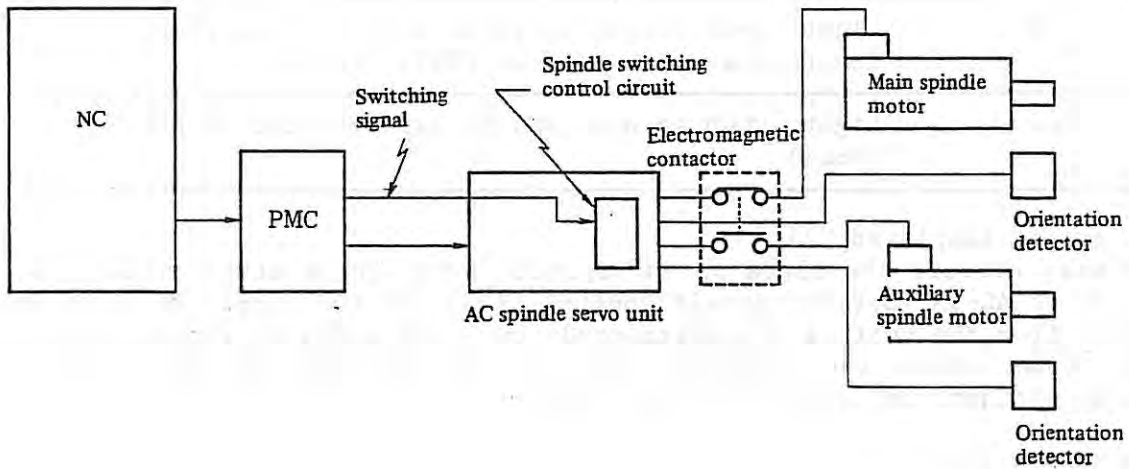

Table 8.1 Configuration elements

Application unit	Name	Order diagram number	PCB diagram number
Models 6S - 26S	Spindle switching control circuit (Without orientation signal switching)	A06B-6059-J701	A20B-1000-0654
	Spindle switching control circuit (With orientation signal switching)	A06B-6059-J702	A20B-1000-0655

8.2 Adjusting Spindle Switching Control Circuit

PCB diagram number A20B-1000-0654 (Without orientation signal switching)
 A20B-1000-0655 (With orientation signal switching)

1) Display contents

Displays the motor selection state and alarm by using the light emitting diode.

Refer to Fig. 8.2.1 for the installation position.

Name	Lighting color	Description
MAIN	Green	Lights when MAIN side motor is selected.
SUB	Green	Lights when SUB side motor is selected.
MCMIS	Red	Lights when status of power line differs from instructed side (MAIN or SUB). (Note)
ROMIS	Red	Lights when an abnormality has occurred in ROM. (Note)

Note) When alarm is displayed (lit)

In the main circuit the alarm on the spindle switching control circuit is displayed as AL-15 (option circuit abnormality), and the supply of power to the motor from the unit is instantaneously cut, and stops by running idly. At this time, check the lighting condition of the LEDs on the spindle switching circuit, and carry out the remedy.

a) When MCMIS is lit

Item	Cause	Checking method	Remedy
1	Defect of electromagnetic contactor and drive relay.	Check if there is deposit on contact, etc.	Replace pertinent part.
2	Defect in wiring. (Disconnection, contact defect, etc.)	Check connection between spindle switching control circuit and electromagnetic contactor.	
3	PCB defect.		Replace PCB.

b) When ROMIS is lit

Item	Cause	Checking method	Remedy
1	Defect of ROM.		Replace ROM.
2	PCB defect.		Replace PCB.

2) Setting jumper SH

Use in combination with variable resistor RV5 when clamping maximum rotation speed.

Setting	MAIN	SUB
Clamps MAIN side	o	x
Clamps SUB side	x	o
Does not clamp	x	x

o: Short
x: Open

Refer to Fig. 8.2.1 for the installation position.

3) Variable resistor RV5

The speed command voltage (VCMD) on the side specified by setting jumper SH can be clamped.

It has no relationship when SH is OFF.

The speed command voltage can be checked by check pin VCMD.

Refer to Fig. 8.2.1 for the installation position.

Example of using maximum rotation speed clamp

MAIN side: MODEL 12S

SUB side : MODEL 3S When using at 6000 rpm

SH	SUB side short circuit
RV5	Clamped at VCMD 7.5 V

Fig. 8.2.1 Installation position of LEDs, setting jumpers, variable resistor, and check terminals PCB diagram number A20B-1000-0654,-0655

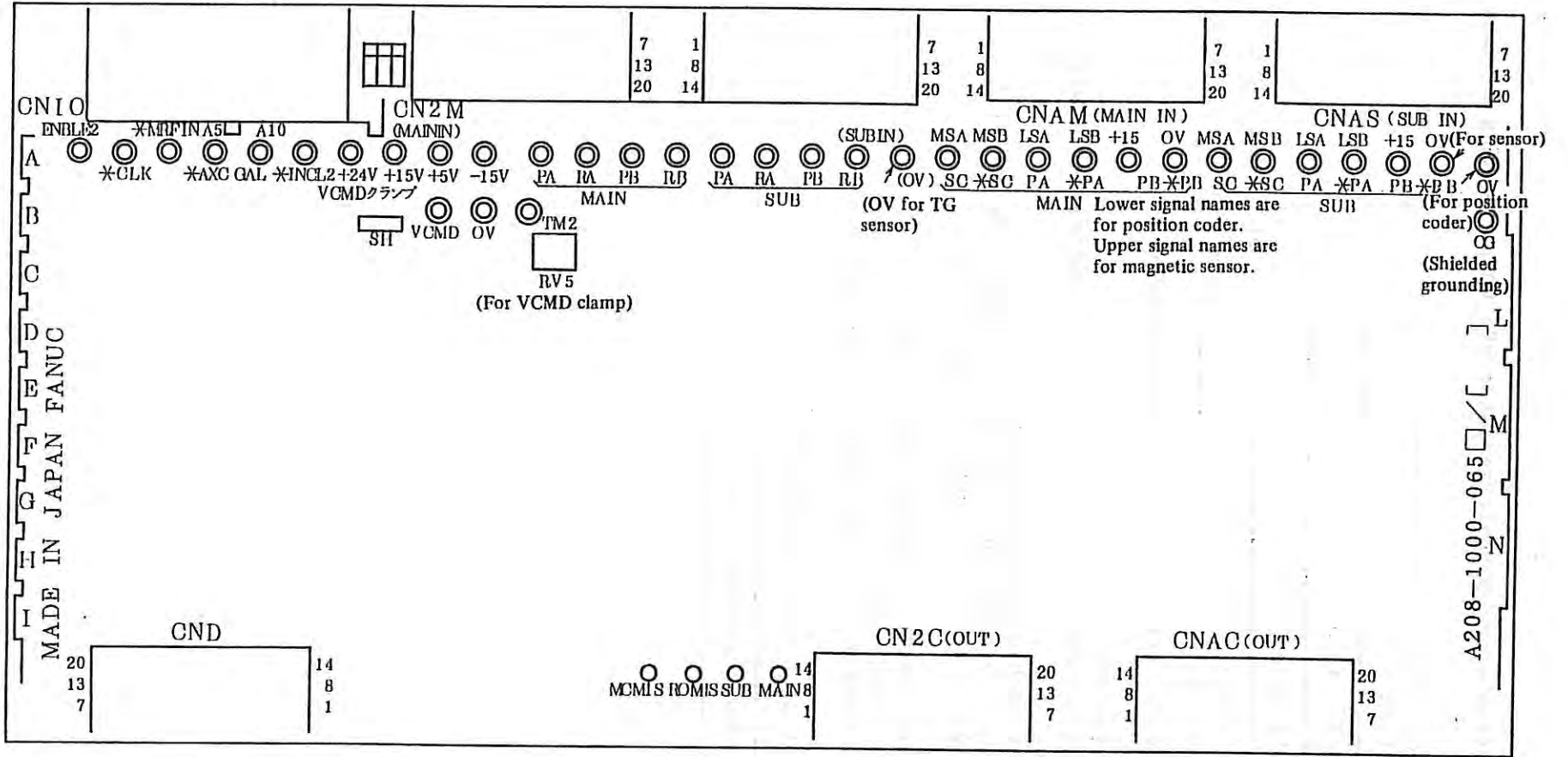

9. SPEED RANGE SWITCHING CONTROL CIRCUIT

This describes the maintenance when the speed range switching control circuit is added to control by switching the coil of a motor which has a coil with 2 differing characteristics to the AC spindle servo unit. The speed range switching control circuit applies to models 6S - 26S.

Refer to chapter 5 for the contents of the parameter. According to the status of the coil (MAIN or SUB), parameters whose contents cannot be checked are set in each model. Therefore, when checking and changing the contents of these parameters, check and change by changing the status of the coil.

Refer to section 5.3 or 5.4 for the method of checking and changing the contents of the parameter.

Note) Regarding the electromagnetic contactor to switch the coil (output characteristics), take the interlock so that it is not mutually and simultaneously set ON.

9.1 Configuration

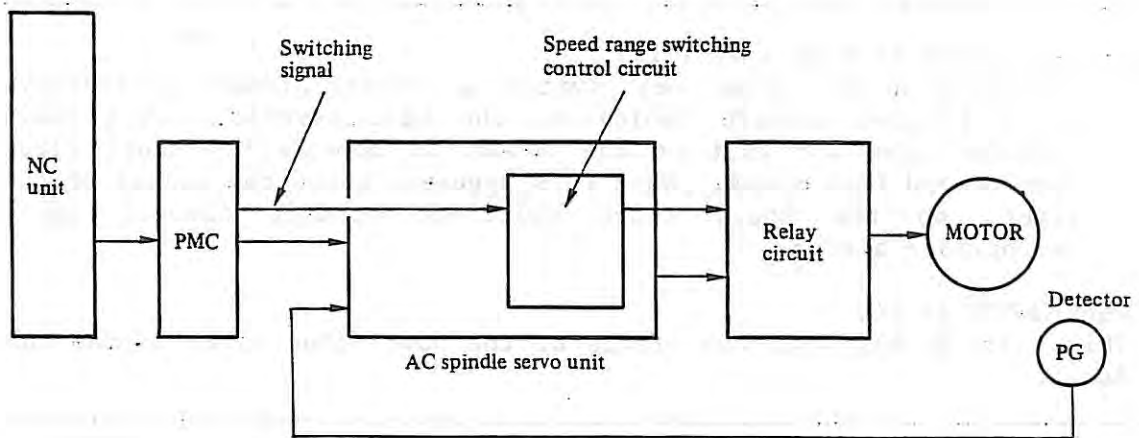

Table 9.1 Configuration elements

Application unit	Name	Order diagram number	PCB diagram number
Models 6S - 26S	Speed range switching control circuit	A06B-6059-J703	A20B-1000-0653

9.2 Adjusting Speed Range Switching Control Circuit

PCB diagram number A20B-1000-0653

1) Display contents

Displays the motor selection state and alarm by using the light emitting diode.

Refer to Fig. 9.2 for the installation position.

Name	Lighting color	Description
MAIN	Green	Lights when high-speed side coil is selected.
SUB	Green	Lights when low-speed side coil is selected.
MCMIS	Red	Lights when status of power line differs from instructed side (MAIN or SUB). (Note)
ROMIS	Red	Lights when an abnormality has occurred in ROM. (Note)

Note) When alarm is displayed (lit)

The alarm on the speed range switching control circuit is displayed as AL-15 (option circuit fault) on the main circuit. When power is supplied from the unit to the motor, it momentarily short circuits, runs on and then stops. When this happens, check the status of the LED lights on the speed range switching control circuit and take appropriate action.

a) When MCMIS is lit

This alarm lights when the status of the power line check signal shows a fault.

Item	Cause	Checking method	Remedy
1	Defect of electromagnetic contactor and drive relay.	Check if deposit on contact, etc.	Replace pertinent part.
2	Defect in wiring. (Disconnection, contact defect, etc.)	Check connection between speed range switching control circuit and electromagnetic contactor.	
3	PCB defect.		Replace PCB.

b) When ROMIS is lit

Item	Cause	Checking method	Remedy
1	Defect of ROM.		Replace ROM.
2	PCB defect.		Replace PCB.

- c) When either MCMIS or ROMIS become AL-15
 When the switching complete signal is not inputted within 0.5 seconds after the switching request signal is inputted, MCMIS and ROMIS will display only AL-15 without lighting.
 In this case, check the connections between the speed range switching control circuit and PMC, and between the PMC and spindle control circuit.

2) Other

When the electromagnetic contactor is severely repeating ON/OFF

Item	Cause	Checking method	Remedy
1	Interlock could not be taken.		Take interlock by changing the wiring.
2	The speed is overshooting.	Check the TSA waveform.	Adjust the speed loop gain in order that the speed overshoot ceases. Either make F-21 large or F-25 smaller.

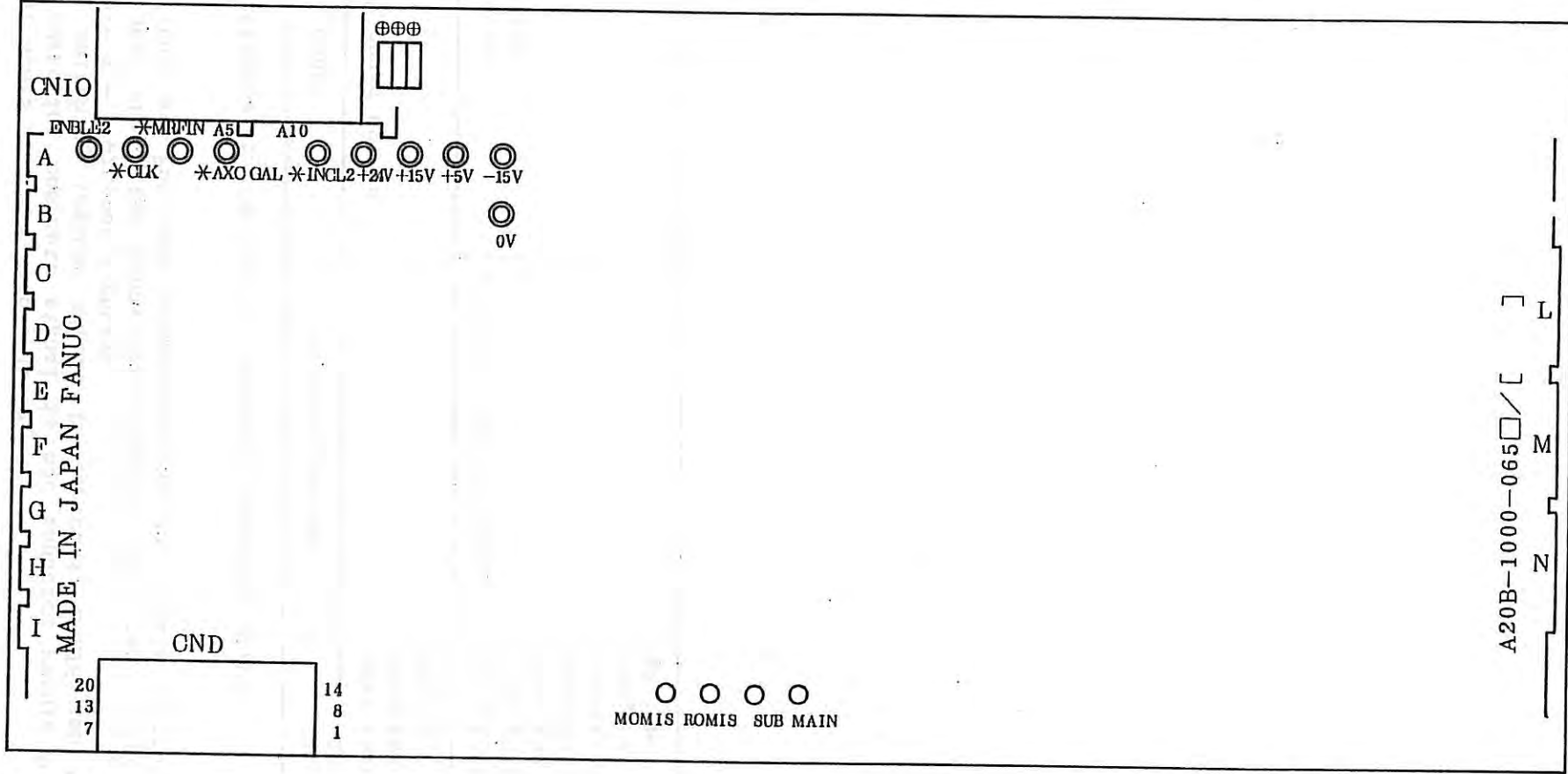

Fig. 9.2 Installation position of LEDs, setting jumpers, variable resistor, and check terminals PCB diagram number A20B-1000-0653

10. SPEED GAIN SWITCHING CIRCUIT

This describes the maintenance when the speed gain switching circuit is added to control by switching the speed loop gain inside the unit to the AC spindle servo unit by an external signal.

The speed gain switching circuit applies to models 6S - 26S.

In models 1S - 3S it is built into the spindle control PCB. Refer to section 5.1.

10.1 Configuration

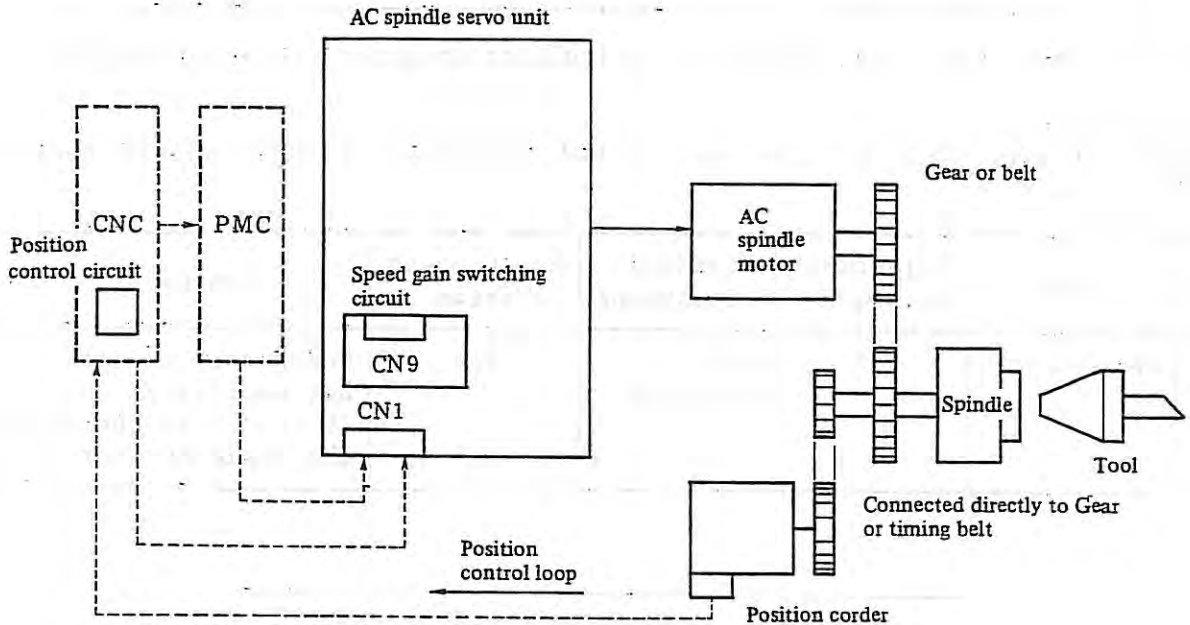

Table 10.1 Configuration elements

Application unit	Name	Order diagram number	PCB diagram number
Models 6S - 26S	Speed gain switching circuit	A06B-6059-J700	A20B-1700-0021

10.2 Adjusting Speed Gain Switching Circuit

Application PCB diagram number A16B-1700-0021

1) Display contents

Refer to Fig. 10.2 for the installation position of the light-emitting diode.

Name	Lighting color	Description
LED1 (ORIENTATION)	Green	The orientation command (ORCM) is used as the speed loop gain switching signal, and it lights if this signal is inputted. (Note)

Note) Differs from the contents of spindle orientation (refer to chapter 7).

2) Adjustment

Refer to Fig. 10.2 for the installation position of the variable resistor RVI.

No.	Item	Adjustment location	Standard adjustment	Measurement location	Contents
1	Speed loop gain	RVI	7th division	TSA1	Check that it does not oscillate. If turned to the right, the rigidity increases.

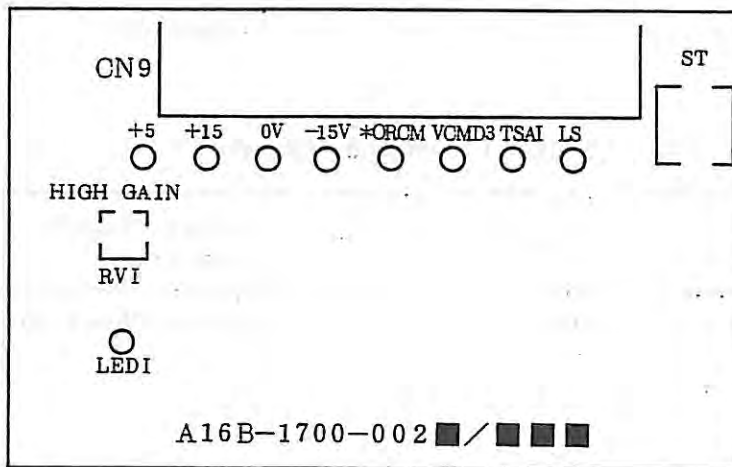

Fig. 10.2 Installation position of LEDs, setting jumpers, variable resistor, and check terminals PCB diagram number A16B-1700-0021

11. SIGNAL CONVERSION CIRCUIT

This section describes the maintenance operation for the signal conversion circuit which, on the one hand, receives signals from the built-in sensors used in the AC spindle motors and built-in motors and, on the other hand, outputs speed detection signals and position coder signals.

An upgraded model A06B-6063-H730 has been added. This model is compatible with the existing three models such as A06B-6044-H603, H605 and H606. (For compatibility, see (1)-(c) in Subsection 11.2.)

11.1 Configuration

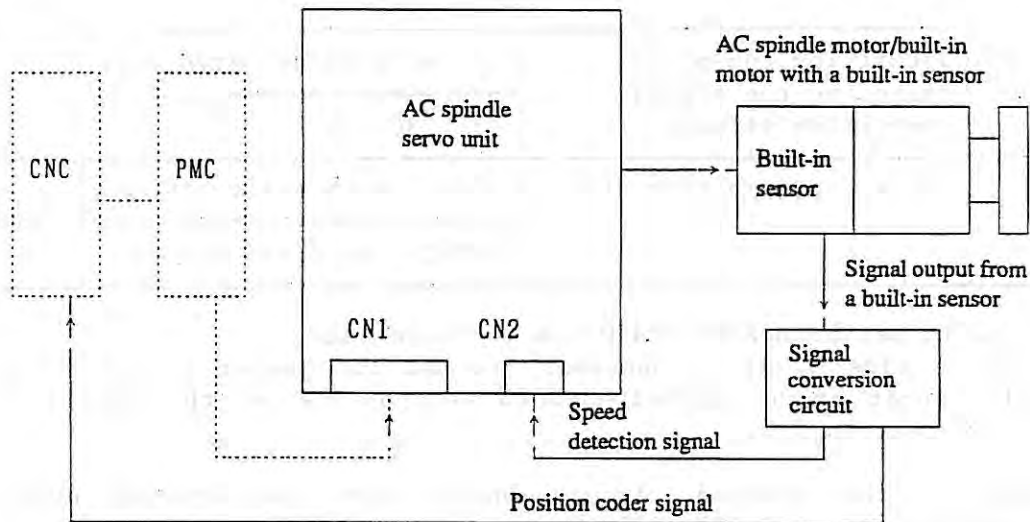

Table 11.1 Configuration elements

Application unit	Name	Order drawing No.	Printed circuit board drawing No.	Remarks
Common for all models	Signal conversion circuit	A06B-6044-H603	A20B-9000-0180	
		A06B-6044-H605	A16B-1600-0370	High-speed type
		A06B-6044-H606	A16B-1600-0390	Special type (Note)
		A06B-6063-H730	A16B-1600-0440	Unified upgraded type compatible with the 3 types shown above

Note) This type is used to convert a sensor signal of 512 pulses/rev. to that of 1024 pulses/rev. Normally a signal of 256 pulses/rev. is converted to that of 1024 pulses/rev. However, some models such as 1S, 2S, 3S and 6S/12000 rpm convert it to a signal of 512 pulses/rev.

11.2 Adjusting Signal Conversion Circuit

It is necessary to execute the following adjustment and output waveform checking procedures especially when the built-in sensor is attached by the user.

1) Jumper

For the mounting positions for each jumper, see Figure 11.2 (a) - (c).

- a) With respect to the printed circuit board with the drawing number of A20B-9000-0180, the figure is applied to those with version number 07C and the later.

No.	Pin No.	Content	Setting	Standard setting
1	SH01, 02 (Note)	Specifying the power source to the signal conversion circuit	A: AC spindle servo unit	B
			B: PMC, NC	
2	SH03	Phase Z temperature drift	OPEN: With drift offset	SHORT
			SHORT: No drift offset	

Note) Make sure to set both SH01 and 02 on the same side.

When set to side A, it is necessary to set the jumper S7 to "A" on the printed circuit board (A20B-1003-0010 version 10B or the later) of the unit. See section 5.2.

- b) In case of the printed circuit board with the drawing number of A16B-1600-0370 or A16B-1600-0390

No.	Pin No.	Content	Setting	Standard setting
1	SH1, 2 (Note)	Specifying the power source to the signal conversion circuit	A: AC spindle servo unit	B
			B: PMC, NC	
2	SH3	Phase Z temperature drift	A: With drift offset	B
			B: No drift offset	
3	SH4 (Note 2)	Adjusting phase A (between CH7-10) output gain	A: 0.9	B
			B: 1.0	
	SH5 (Note 2)	Adjusting phase B (between CH8-10) output gain	OPEN: 1.1	

Note 1) Make sure to set both SH01 and 02 on the same side.

When set to side A, it is necessary to set the jumper S7 to "A" on the printed circuit board (A20B-1003-0010 version 10B or the later) of the unit. See section 5.2.

Note 2) When the Vs for the signal between CH20-CH10 or CH21-CH10 is out of the standard range, the signal amplitude can be changed without changing the sensor attaching position. See 2) - a). However, the Vs does not meet the standard value even after the setting is changed, it is needed to change the attaching position. In addition, this function cannot be used for the printed circuit board with the drawing number of A20B-9000-0180.

c) In case of the printed circuit board with the drawing number of A16B-1600-0440

No.	Pin No.	Content	Setting	Standard setting																									
1	SH1, 2 (Note)	Specifying the power source to the signal conversion circuit	A: AC spindle servo unit	B																									
			B: PMC, NC																										
2	SH3	Phase Z temperature drift	A: With drift offset	B																									
			B: With drift offset																										
3	SH4 (Note 2)	Adjusting phase A (between CH7-10) output gain	A: 0.9	OPEN																									
			OPEN: 1.0																										
	SH5	Adjusting phase B (between CH8-10) output gain	B: 1.1																										
4	SH6, 7 (Note 3)	Adjusting the magnifications for number of input signals (SIN wave) and that of output signals (pulse). An example is shown below.		SH6: B SH7: A																									
<table border="1"> <thead> <tr> <th>SH6</th> <th>SH7</th> <th>Magnification</th> <th>Number of input signals (SIN wave) + Number of output signals (pulse)</th> <th>Remarks (on compatibility)</th> </tr> </thead> <tbody> <tr> <td>A</td> <td>A</td> <td>2</td> <td>512 + 1024</td> <td>Compatible with A16B-1600-0390</td> </tr> <tr> <td>B</td> <td>A</td> <td>4</td> <td>256 + 1024 128 + 512</td> <td>Compatible with A20B-9000-0180 and A16B-1600-0370</td> </tr> <tr> <td>A</td> <td>B</td> <td>8</td> <td>Not used</td> <td></td> </tr> <tr> <td>B</td> <td>B</td> <td>16</td> <td>Not used</td> <td></td> </tr> </tbody> </table>					SH6	SH7	Magnification	Number of input signals (SIN wave) + Number of output signals (pulse)	Remarks (on compatibility)	A	A	2	512 + 1024	Compatible with A16B-1600-0390	B	A	4	256 + 1024 128 + 512	Compatible with A20B-9000-0180 and A16B-1600-0370	A	B	8	Not used		B	B	16	Not used	
SH6	SH7	Magnification	Number of input signals (SIN wave) + Number of output signals (pulse)	Remarks (on compatibility)																									
A	A	2	512 + 1024	Compatible with A16B-1600-0390																									
B	A	4	256 + 1024 128 + 512	Compatible with A20B-9000-0180 and A16B-1600-0370																									
A	B	8	Not used																										
B	B	16	Not used																										

Note 1) Make sure to set both SH01 and 02 on the same side.

When set to side A, it is necessary to set the jumper S7 to "A" on the printed circuit board (A20B-1003-0010 version 10B or the later) of the unit. See section 5.2.

Note 2) When the Vs for the signal between CH20-CH10 or CH21-CH10 is out of the standard range, the signal amplitude can be changed without changing the sensor attaching position. See 2) - a). However, the Vs does not meet the standard value even after the setting is changed, it is needed to change the attaching position. In addition, this function cannot be used for the printed circuit board with the drawing number of A20B-9000-0180.

Note 3) This function cannot be used for the printed circuit board with the drawing number of A20B-9000-0180, A16B-1600-0370 or 0390.

2) Adjustment

For the mounting positions for each variable resistor and check pin, see Figure 11.2 (a) - (d).

a) Checking an output signal (for speed detection)

Conditions for measurement:

Rotating direction: Normal (CCW)/reverse (CW)

Speed: 1500 rpm

Point to be measured	V _s	Example waveform
CH20-CH10 CH21-CH10	0.36 to 0.5 V	

Note) During mounting, check to make sure that the ripple voltage of the output signal is 70 mV or less. If it is over 70 mV, the following adjustment may be impossible.

b) Adjusting offset

Conditions for measurement:

Rotating direction: Normal (CCW)/reverse (CW)

Speed: 1600 rpm

Use a digital voltmeter as a measuring device. (Use its DC range.)

Adjusting part	Point to be measured	Target value for A20B-9000-0180, A16B-1600-0370 and 0390	Target value for A16B-1600-0440	Remarks
VR1	CH7-CH10	0 <u>+</u> 56 mV	0 <u>+</u> 35 mV	Adjust so that the target value is satisfied both clockwise and counterclockwise.
VR2	CH8-CH10			
VR3	CH9-CH10	-170 mV to -230 mV		

c) Example waveforms for each adjusted point
 When any abnormality is left while adjusting or even after adjustment, monitor the waveform using a synchroscope or the like.

Point to be measured	CH-CH11 (0V), CH8-CH11 (0V)	CH9-CH11(0V)		
Example waveform				
Vp-p Voltage range	In case of A16B-1600-0370, 390 and A20B-9000-0180	1.32 V - 1.84 V	In case of A16B-1600-0370, 390 and A20B-9000-0180	0.9 V - 2.0 V
	In case of A16B-1600-0440	0.83 V - 1.15 V	In case of A16B-1600-0440	0.9 V - 2.0 V
CH10 Voltage range (Voltage between CH10 and CH11)	In case of A16B-1600-0370, 390 and A20B-9000-0180	2.35 V - 2.65 V	In case of A16B-1600-0370, 390 and A20B-9000-0180	2.35 V - 2.65 V
	In case of A16B-1600-0440	2.61 V - 2.94 V	In case of A16B-1600-0440	2.61 V - 2.94 V
Vdc Voltage range	In case of A16B-1600-0370, 390 and A20B-9000-0180	Voltage at CH10 ±56 mV	In case of A16B-1600-0370, 390 and A20B-9000-0180	2.35 V - 2.65 V
	In case of A16B-1600-0440	Voltage at CH10 ±35 mV	In case of A16B-1600-0440	2.61 V - 2.94 V

3) Waveform for each part

a) Input waveform (at a constant speed of 1500 rpm)

Point to be measured		Standard	Example waveform
Phase differences between CH1 (MA) and CH2 (*MA), and CH3 (MB) and CH4 (*MB) (Each waveform is measured using the CH11 (OV) as common.)		$180 \pm 6^\circ$	
Phase differences between CH1 (MA) and CH3 (MB), and CH2 (*MA) and CH4 (*MB) (Each waveform is measured using the CH11 (OV) as common.)		$90 \pm 3^\circ$ (When rotating clockwise viewed from the detection gear side)	
Amplitude	CH1 (MA), CH2 (*MA) CH3 (MB), CH4 (*MB)	0.33 - 0.46 V	
	CH5 (MZ)	0.9 - 2.0 V	
Neutral point voltage	CH1 (MA), CH2 (*MA) CH3 (MB), CH4 (*MB)	$2.5 \text{ V} \pm 25 \text{ mV}$	
	CH5 (MZ)	$2.5 \text{ V} \pm 35 \text{ mV}$	

b) Output signal 1 (Speed feedback signal) at a constant speed of 1500 rpm

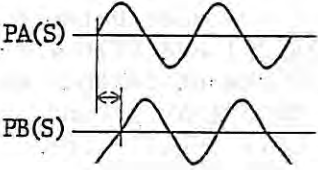
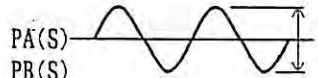
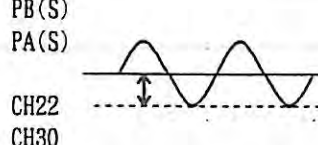
Point to be measured	Standard	Example waveform
Phase differences between CH20 (PA(S)) and CH21 (PB(S)) (Each waveform is measured using the CH11 (0V) as common.)	$90 \pm 10^\circ$ (When rotating clockwise viewed from the detection gear side)	
CH20 (PA(S)) CH21 (PB(S)) amplitude Note: CH28 (PA(S)) CH29 (PB(S)) for A16B-1600-0440	0.32 - 0.54 V	
CH22 (RA(S), RB(S)) voltage Note: CH30 (RA(S), RB(S)) for A16B-1600-0440	2.35 - 2.65 V Note: 2.61 - 2.91 V for A16B-1600-0440	
CH20 (PA(S)) CH21 (PB(S)) neutral point voltage Note: CH28 (PA(S)) CH29 (PB(S)) for A16B-1600-0440	Voltage at CH22 ± 15 mV Note: Voltage at CH30 ± 15 mV for A16B-1600-0440	

c) Output signal 2 (for position coder) at a constant speed of 1500 rpm

Point to be measured		Standard	Example waveform
Phase differences between CH15 (PA(N)) and CH16 (PB(N)) Note: Phase difference between CH16 (PA(N)) and CH17 (PB(N)) for A16B-1600-0440		$90 \pm 10^\circ$ (When rotating clockwise viewed from the detection gear side)	
PA(N), PB(N) SC	High level	Minimum 2.5 V	
	Low level	Maximum 0.5 V	
Duty ratio between PA(N) and PB(N)		$50 \pm 7\%$	
Width of CH17 (SC) Note: CH18 (SC) for A16B-1600-0440		$116 \pm 21 \mu s$	

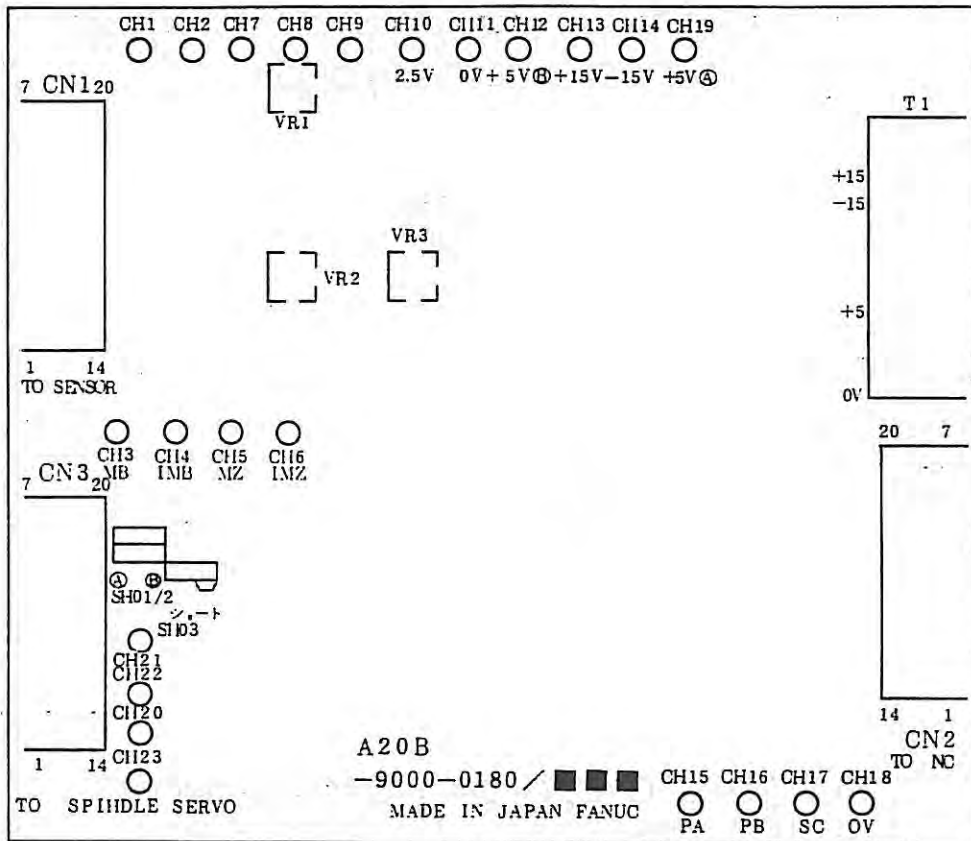

Fig. 11.2 (a) Mounting positions for jumper, variable resistors and test points printed circuit board drawing No.: A20B-9000-0180

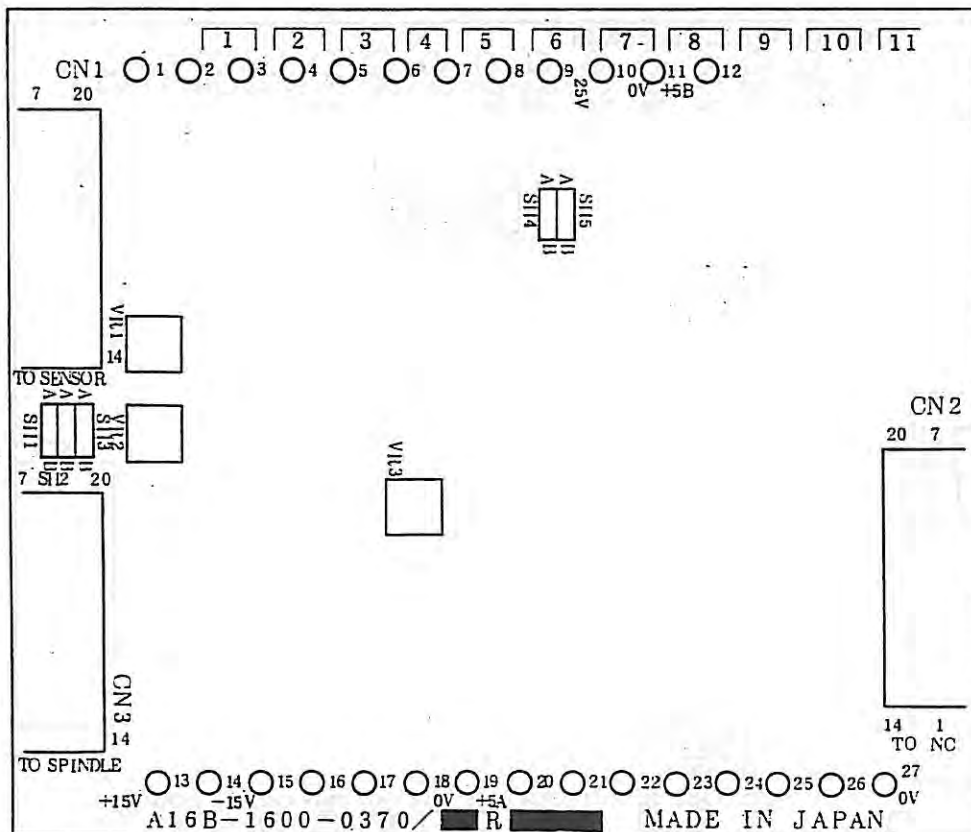

Fig. 11.2 (b) Mounting positions for jumper, variable resistors and test points printed circuit board drawing No.: A16B-1600-0370

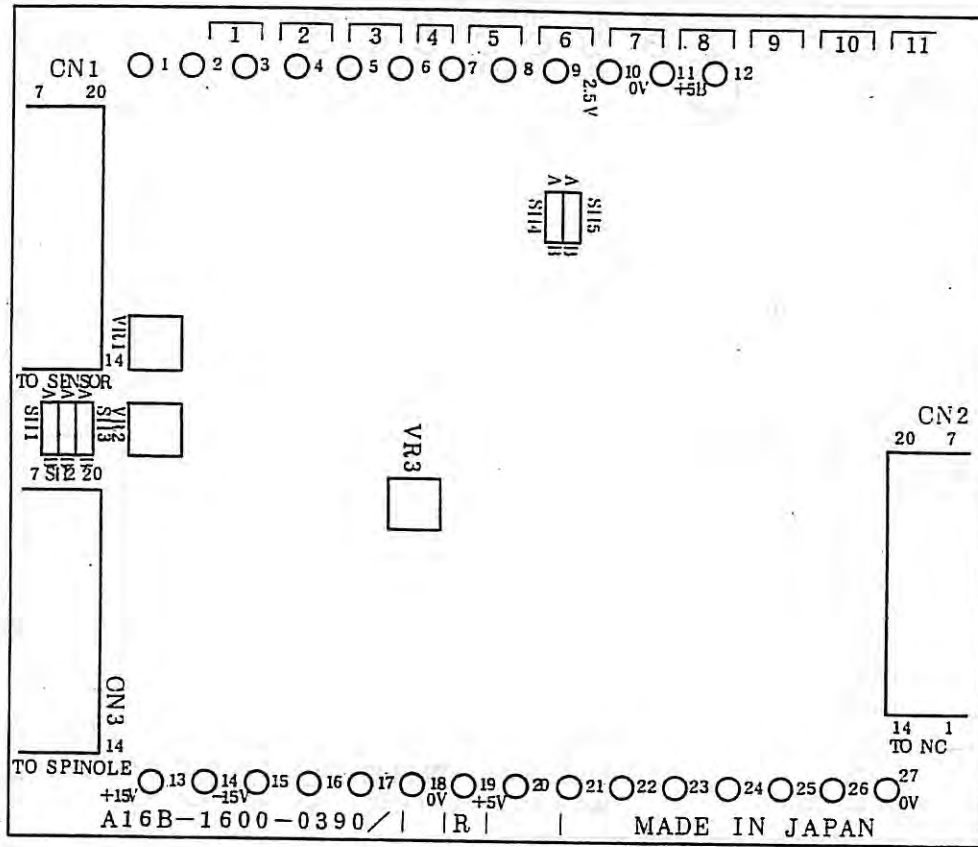

Fig. 11.2 (c) Mounting positions for jumper, variable resistors and test points printed circuit board drawing No.: A16B-1600-0390

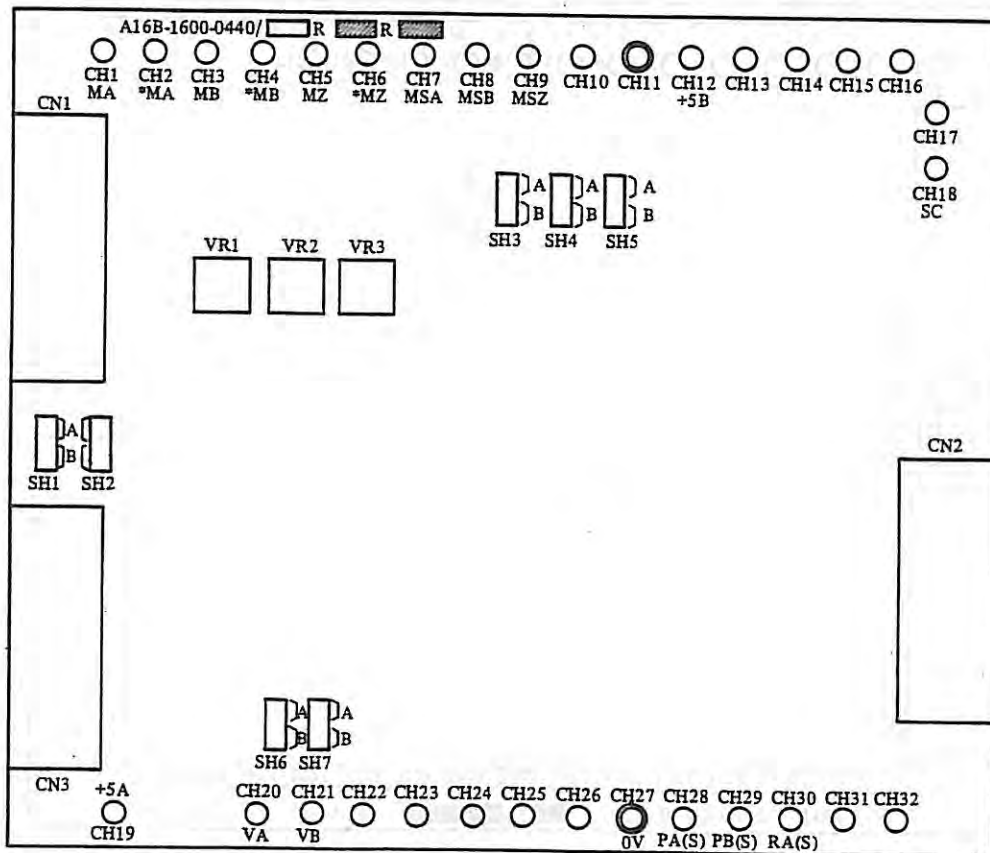
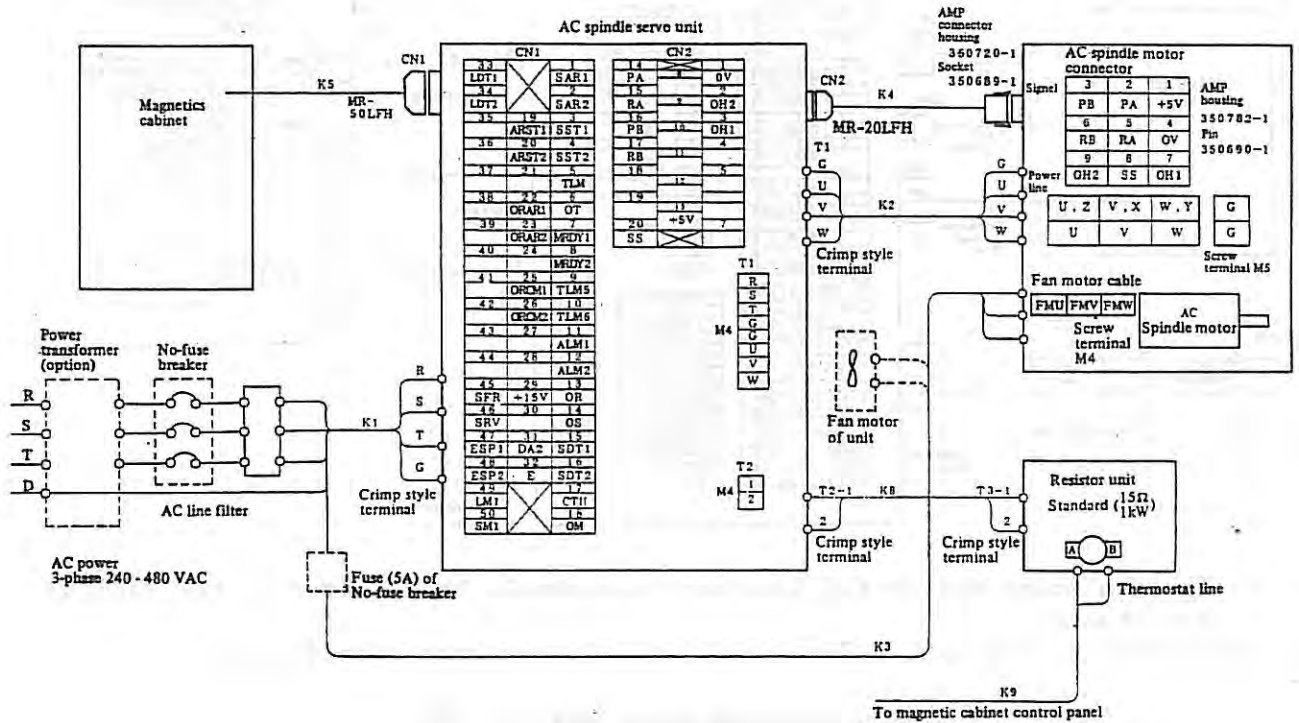

Fig. 11.2 (d) Mounting positions for jumper, variable resistors and test points printed circuit board drawing No.: A16B-1600-0440

APPENDIX

APPENDIX 1 CONNECTION DIAGRAM



Note) The fan motor of unit and no-fuse breaker are prepared by the MTB.

Fig. 1 (a) Connection diagram (models 1S - 3S)

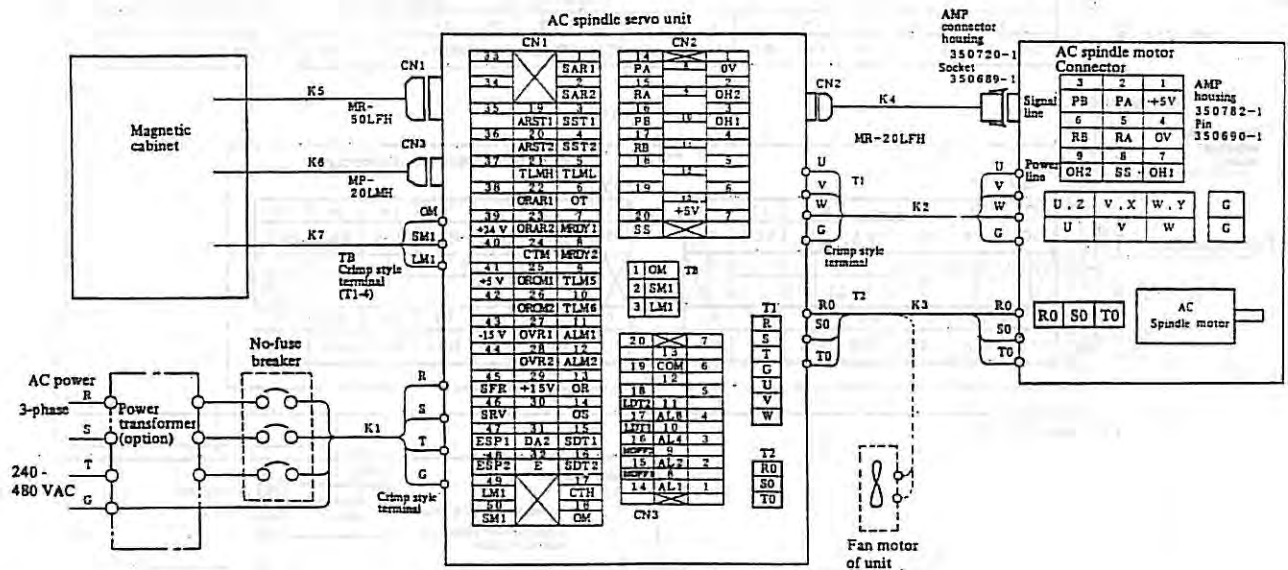

Note) Fan motor and no-fuse breaker are provided by the MTB.

Fig. 1 (b)-1 Connection diagram (models 6S - 26S)
PCB diagram number 09A and earlier

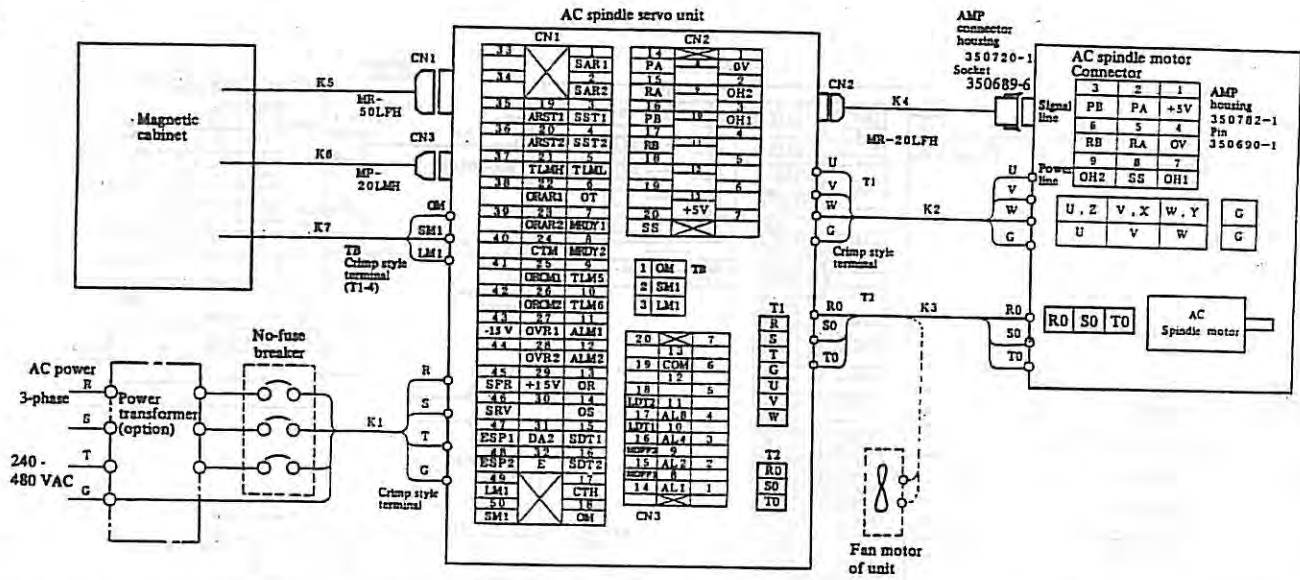

Note 1) The fan motor and dotted line sections should be prepared by the machine tool maker.
 Note 2) In 10B and later, CN1-39, 41, 43, CN3-15, 16 have been deleted.

Fig. 1 (b)-2 Connection diagram (models 6S - 26S)
 PCB version number 10B and later

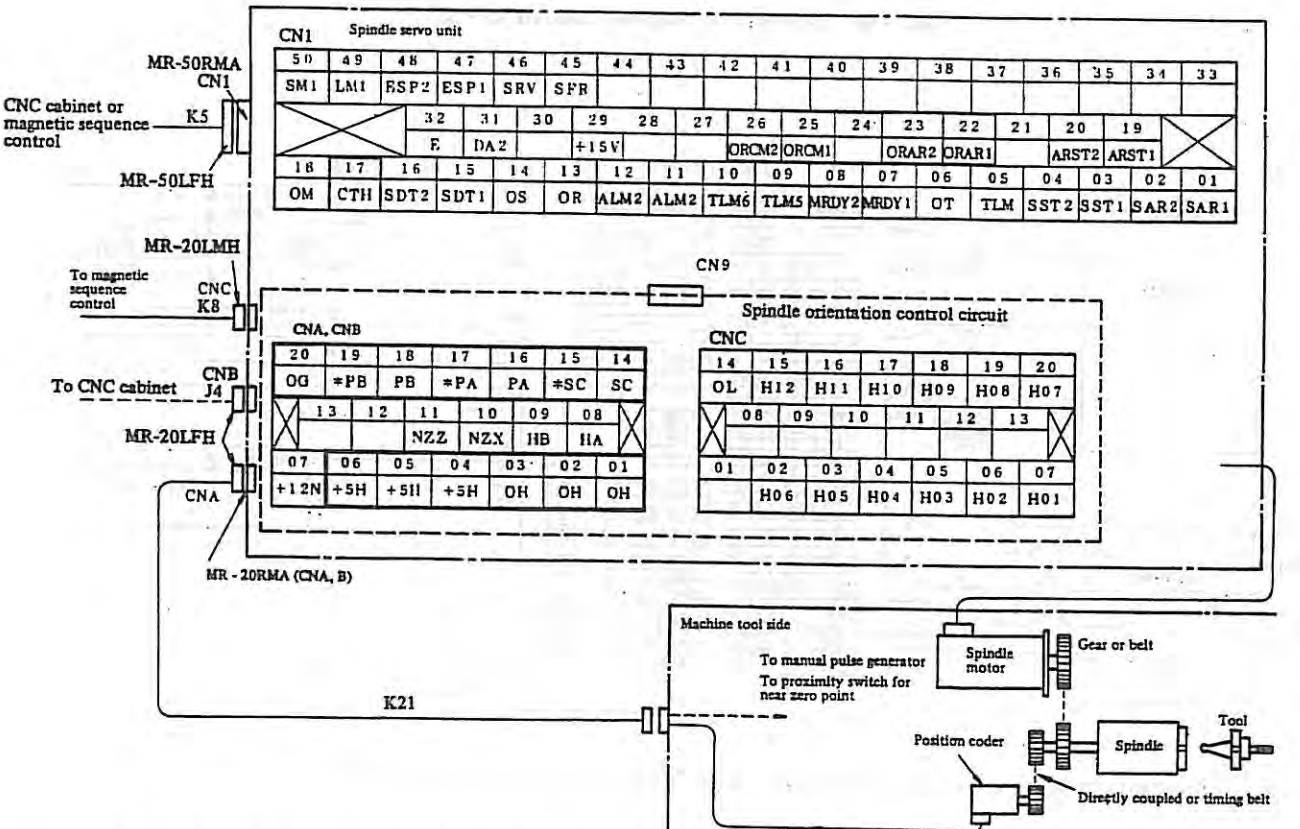

Note 1) Signal cable K22 applies to spindle orientation BR11.

Fig. 1 (c) Spindle orientation connection diagram
 (models 1S - 3S with position coder)

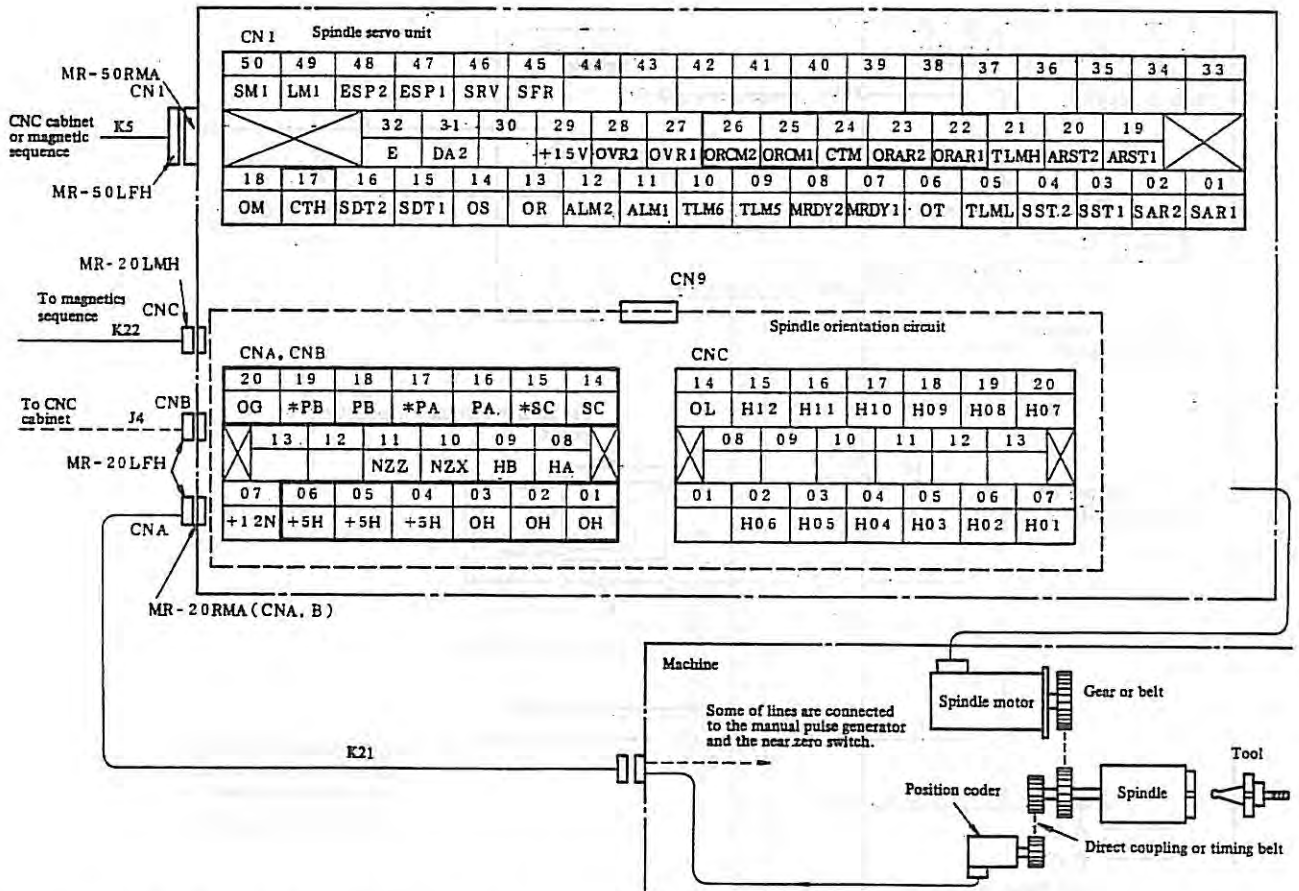

Note) Signal cable K22 is used for the spindle orientation BSII.

Fig. 1 (d) Spindle orientation connection diagram (models 6S - 26S with position coder)

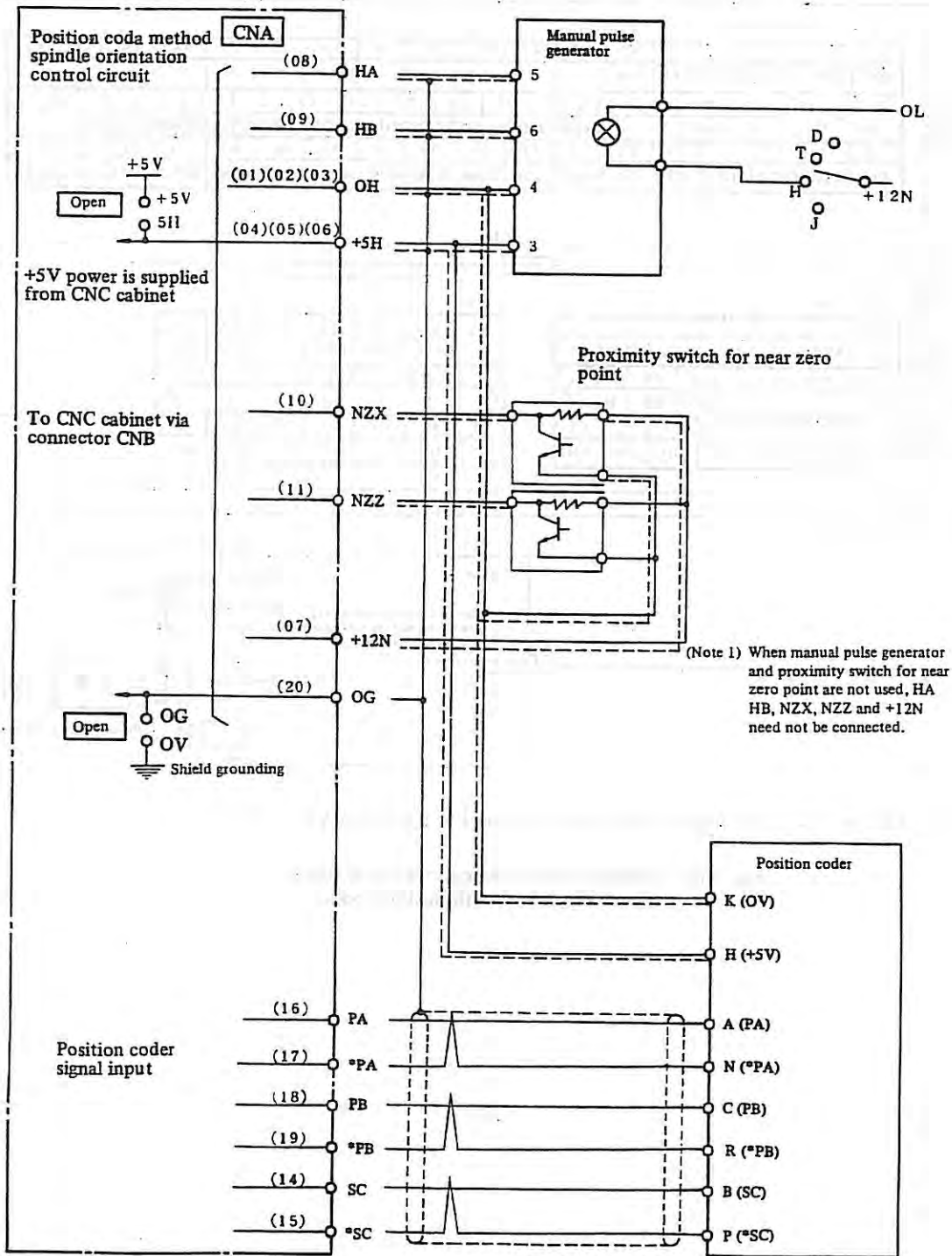
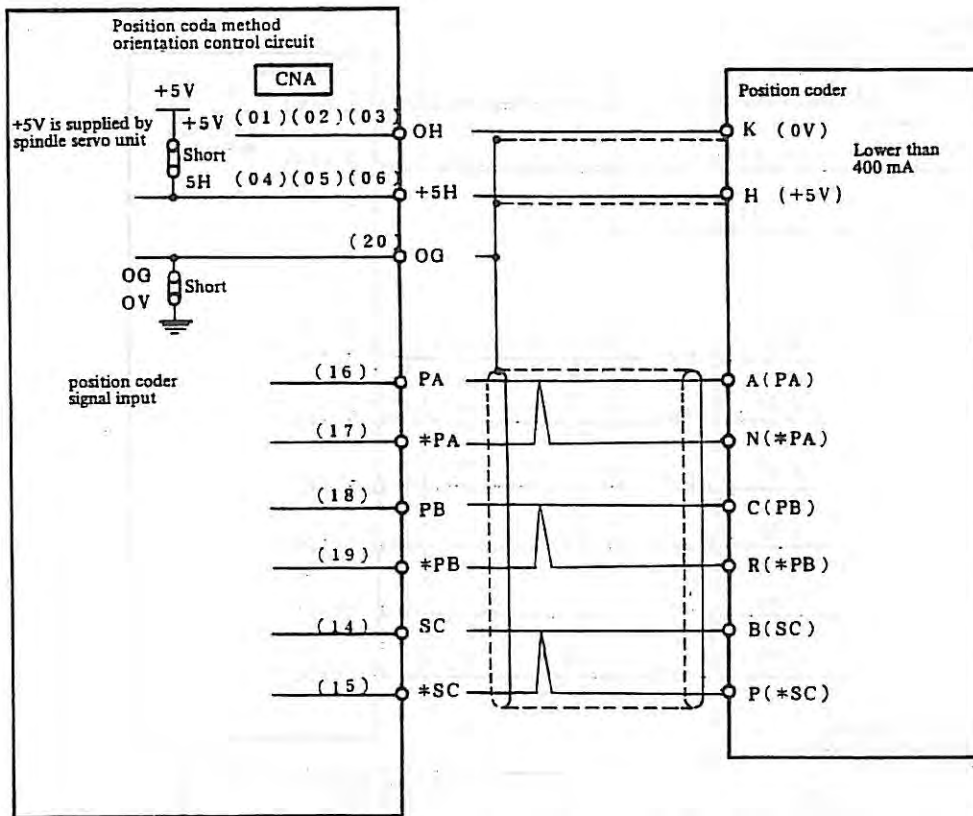

Fig. 1 (e) Spindle orientation connection diagram using position coder
(For lathe and synchronous feed of machining center)



Note) The cable length should be shorter than 20 m between the servo unit and the position coder.

Fig. 1 (f) Spindle orientation connection diagram using position coder
(Only spindle orientation for machining center is used)

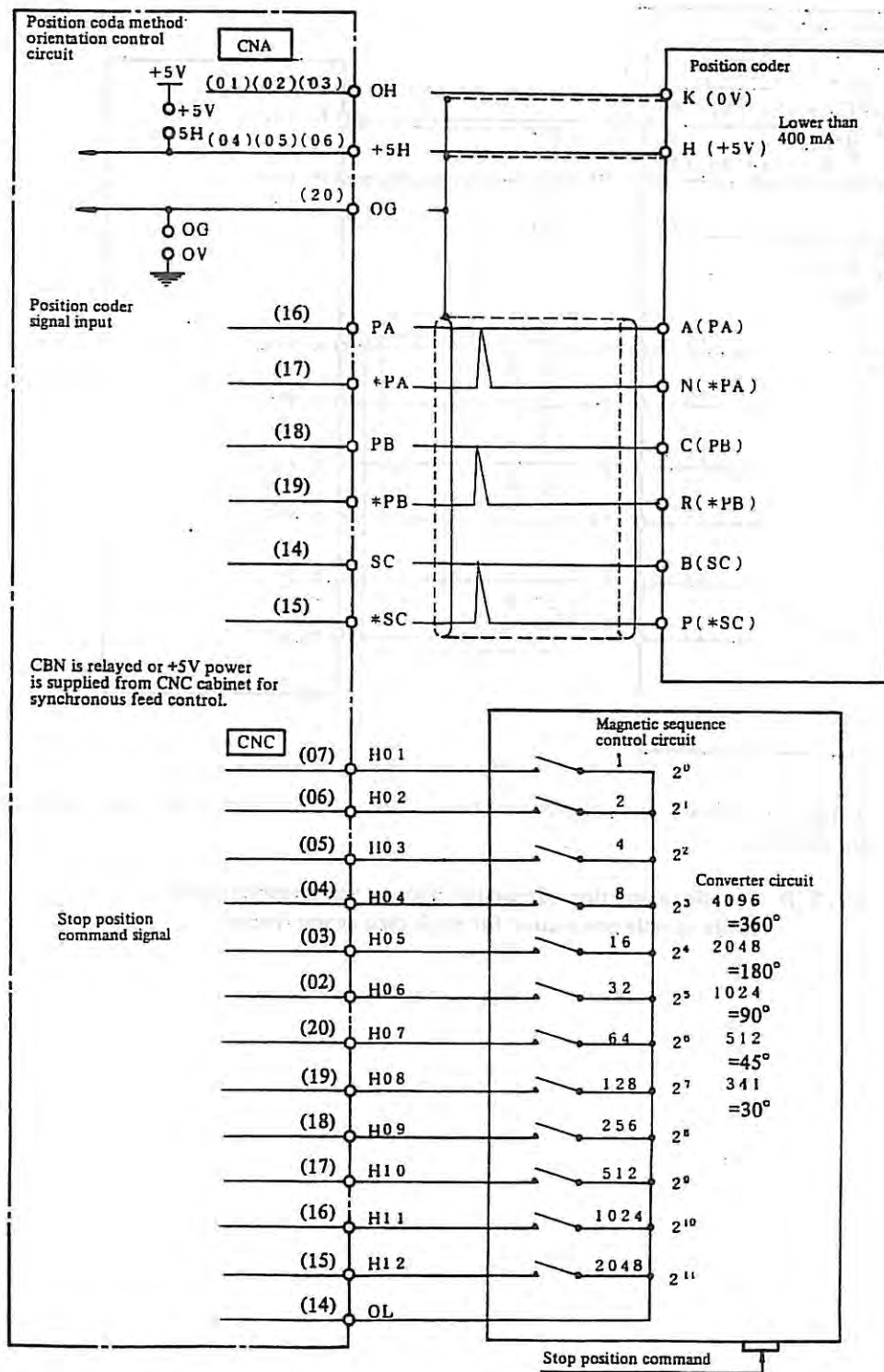

Fig. 1 (g) Spindle orientation connection diagram using position coder (External command of stop position)

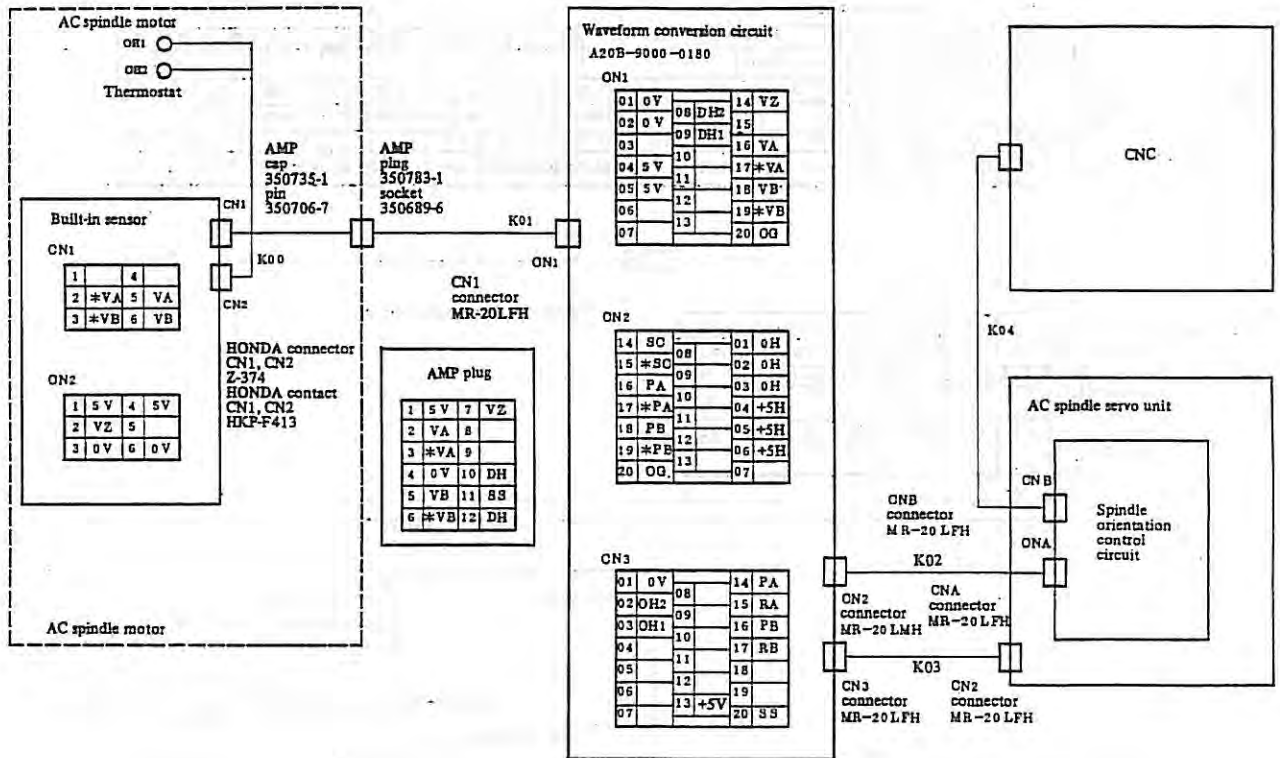

Fig. 1 (h) Spindle orientation connection diagram using built-in sensor

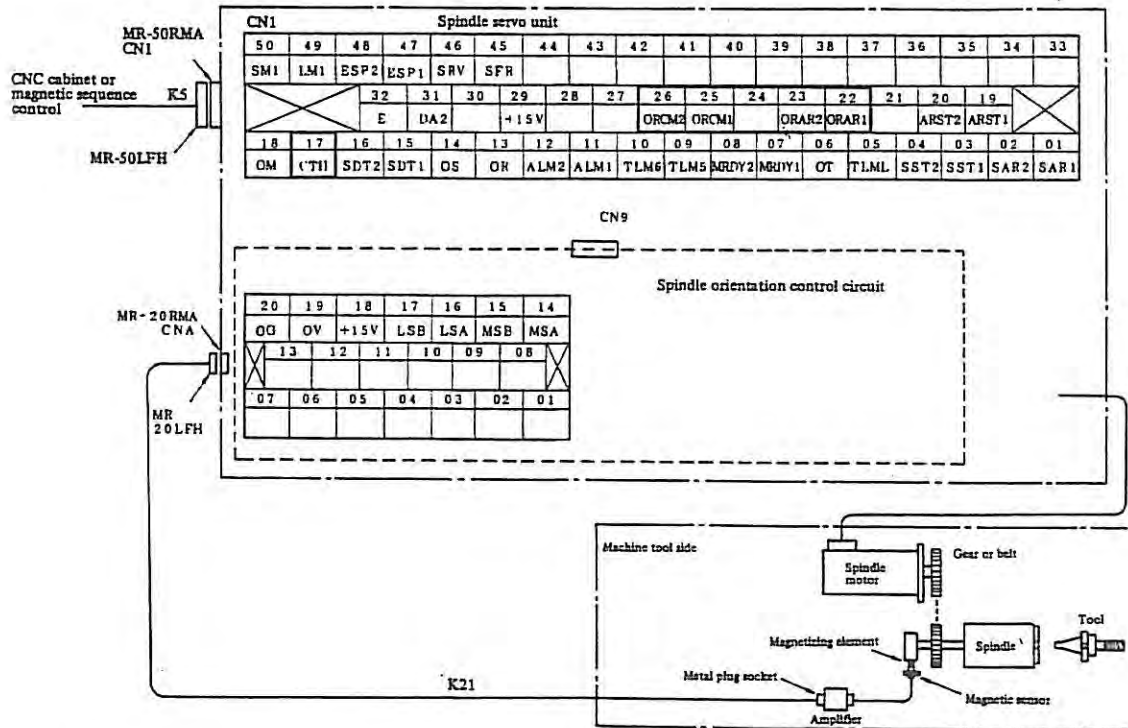

Fig. 1 (i) Spindle orientation connection diagram (models 1S - 3S with magnetic sensor)

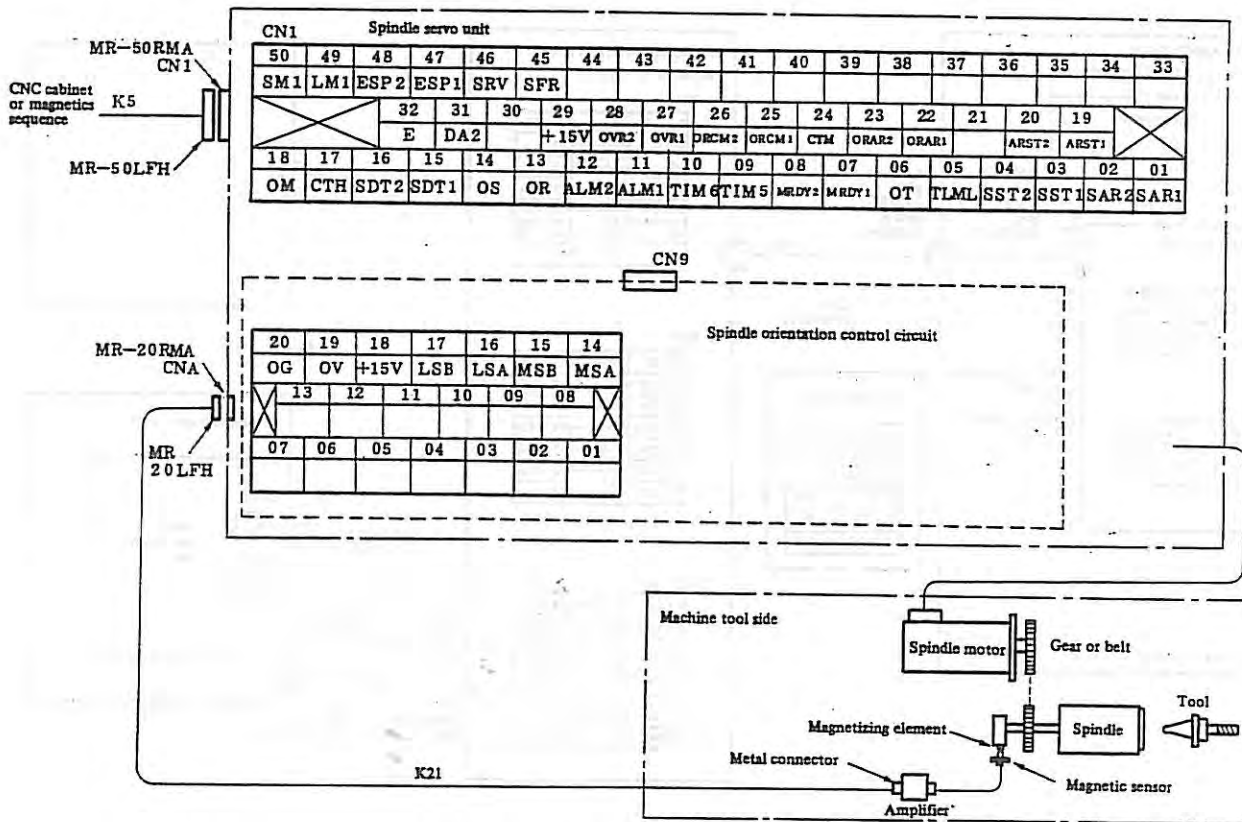
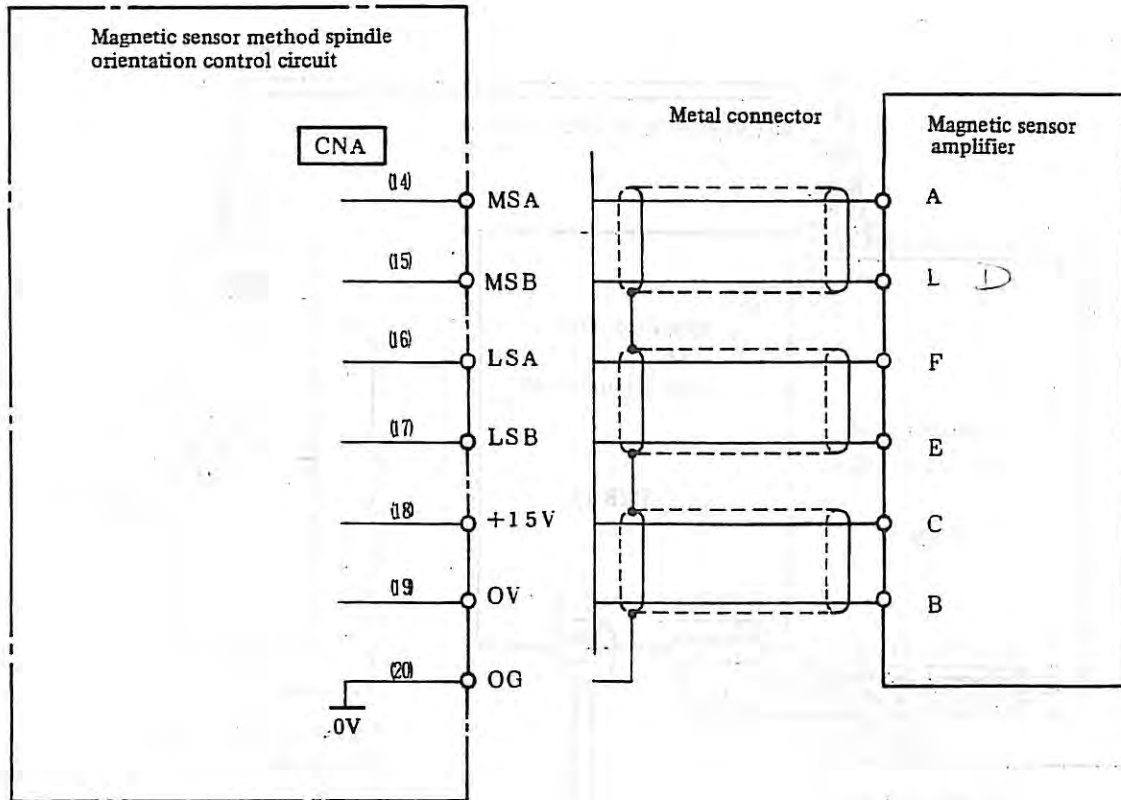

Fig. 1 (j) Spindle orientation connection diagram (models 6S - 26S with magnetic sensor)



Note) The cable length should be shorter than 20 m between the servo unit and the magnetic sensor amplifier.

Fig. 1 (k) Spindle orientation connection diagram using magnetic sensor

APPENDIX 2 CABLE ROUTING

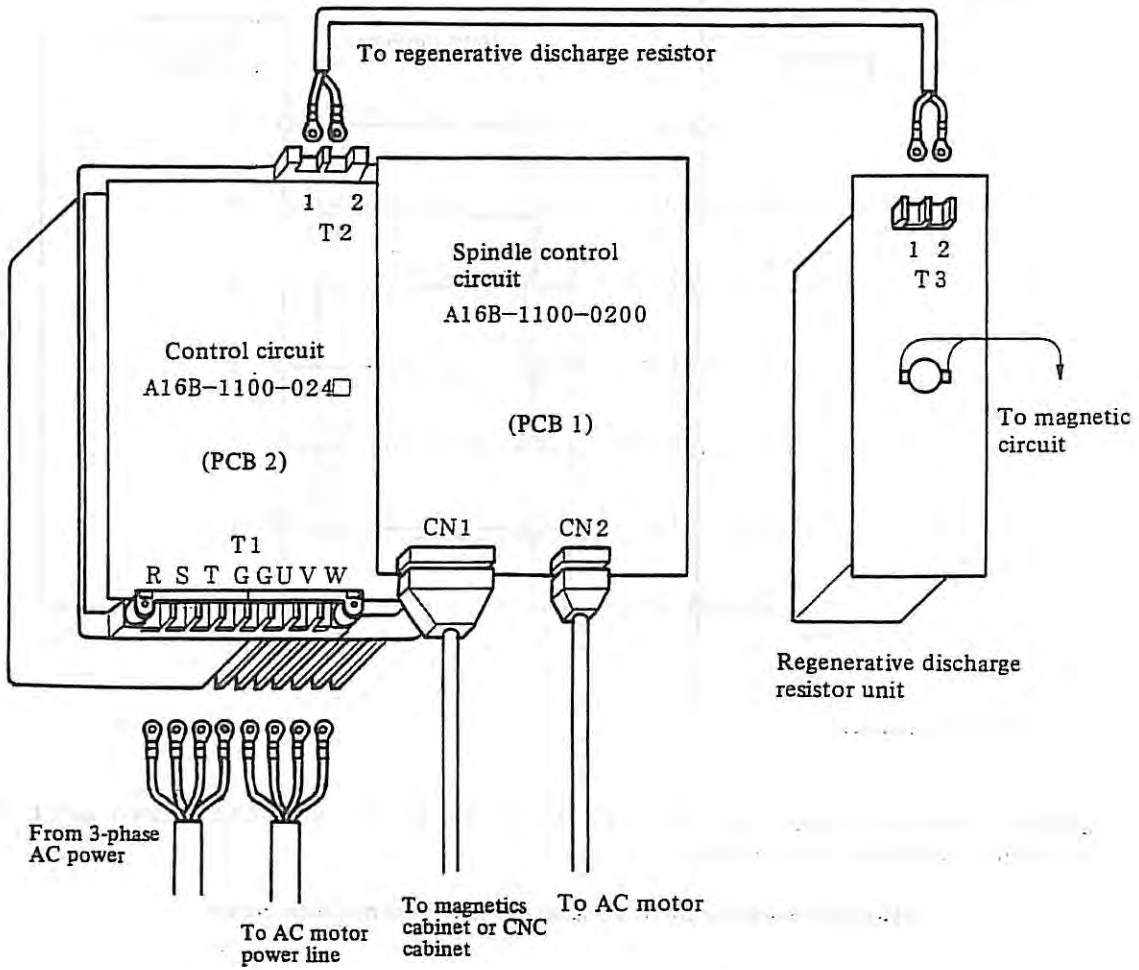

Fig. 2 (a) Cable routing (models 1S - 3S)

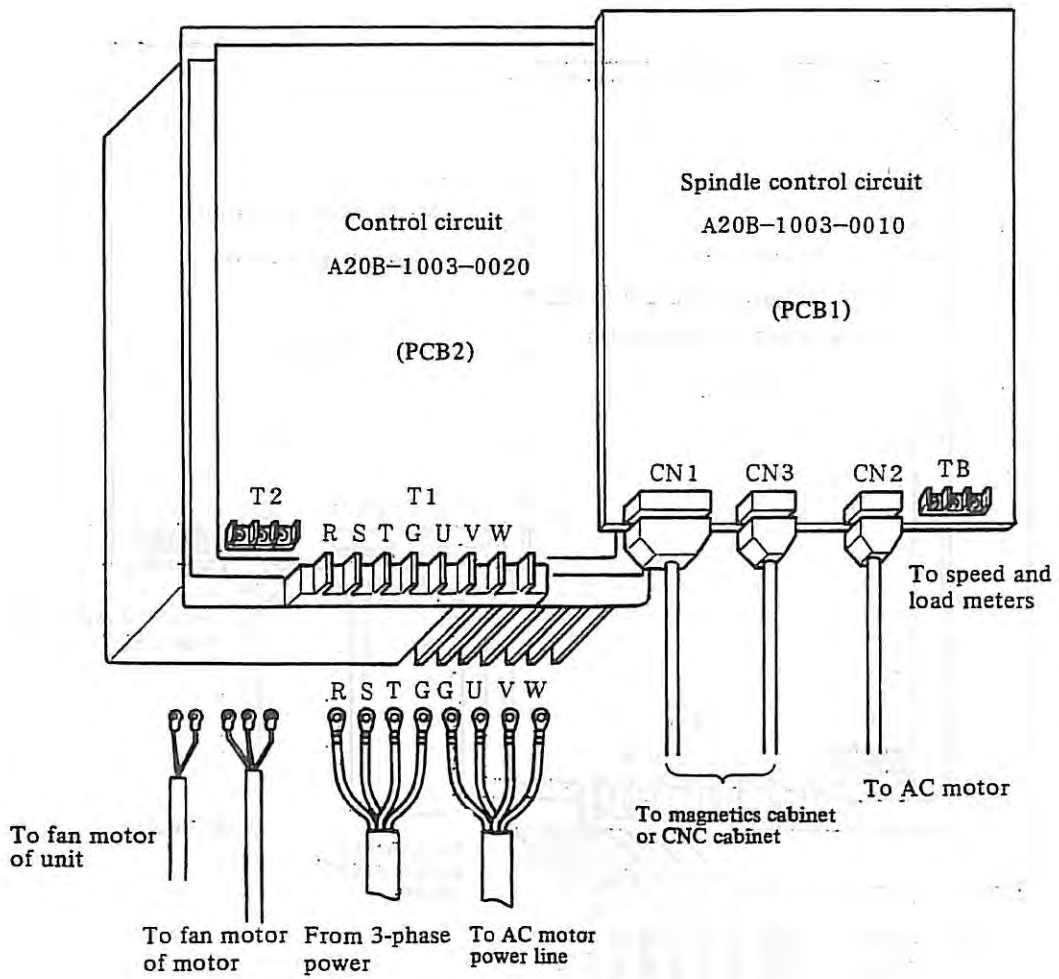

Fig. 2 (b) Cable routing (models 6S - 12S)

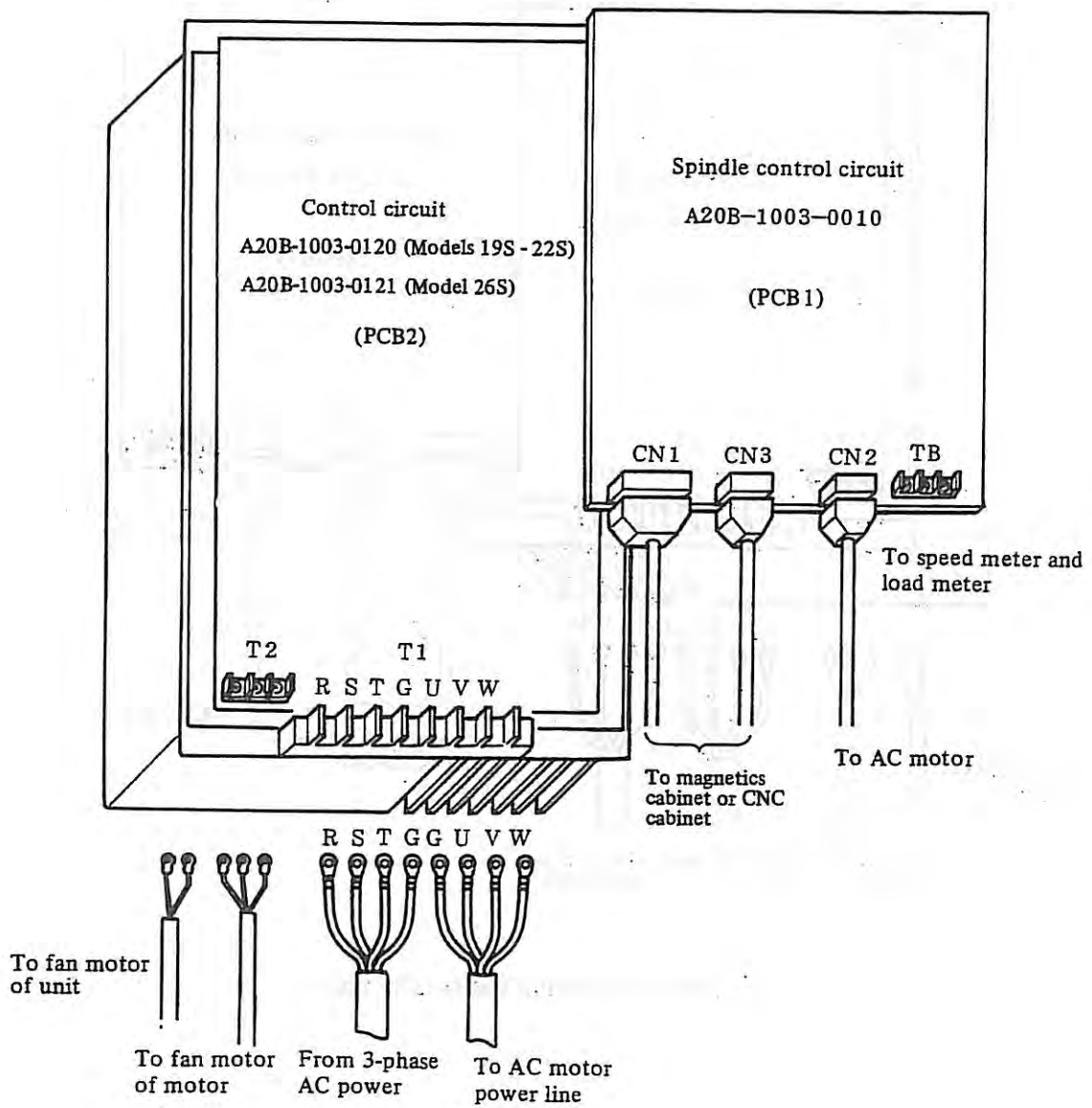
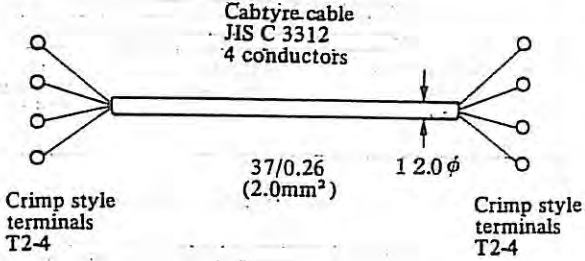
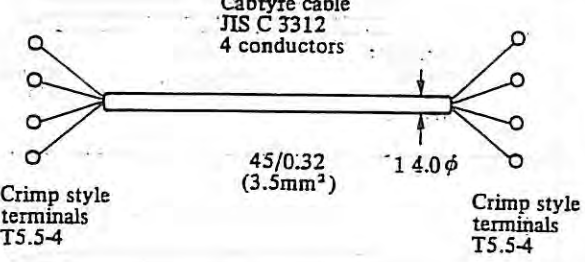
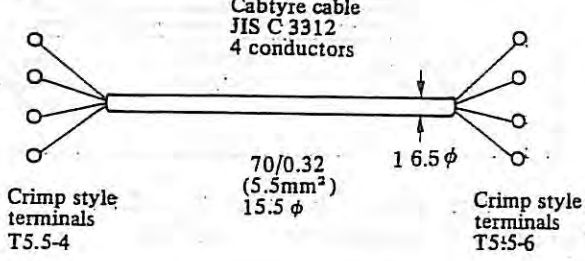
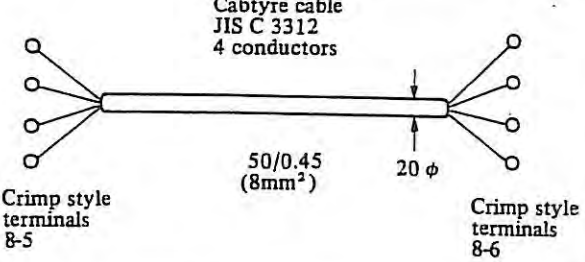
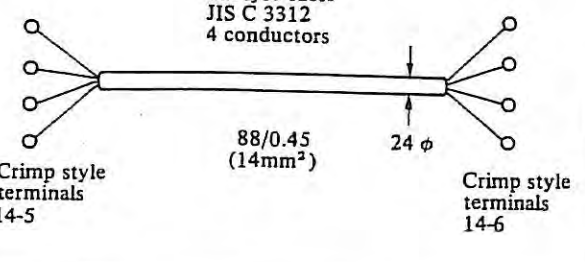
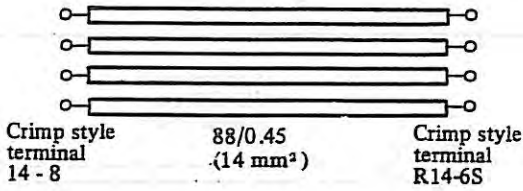

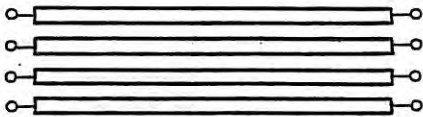

Fig. 2 (c) Cable routing (models 15S - 26S)

APPENDIX 3 CABLE SPECIFICATIONS

The cable specifications are as shown below. Cables are provided by the MTB.
 1) Power and drive lines



Model	Symbol	Specifications	FANUC specification No.
1S (Lower than 5 kVA)	K1 K2	 <p>Cabtyre cable JIS C 3312 4 conductors</p> <p>37/0.26 (2.0mm²)</p> <p>12.0φ</p> <p>Crimp style terminals T2-4</p>	A06B-6052-K201 7 m
1.5S, 2S (Lower than 7 kVA)	K1 K2	 <p>Cabtyre cable JIS C 3312 4 conductors</p> <p>45/0.32 (3.5mm²)</p> <p>14.0φ</p> <p>Crimp style terminals T5.5-4</p>	A06B-6052-K202 7 m
3S (Lower than 12 kVA)	K1 K2	 <p>Cabtyre cable JIS C 3312 4 conductors</p> <p>70/0.32 (5.5mm²)</p> <p>15.5φ</p> <p>Crimp style terminals T5.5-4</p> <p>Crimp style terminals T5.5-6</p>	
6S (Lower than 16 kVA)	K1 K2	 <p>Cabtyre cable JIS C 3312 4 conductors</p> <p>50/0.45 (8mm²)</p> <p>20φ</p> <p>Crimp style terminals 8-5</p> <p>Crimp style terminals 8-6</p>	
8S, 12S (Lower than 25 kVA)	K1 K2	 <p>Cabtyre cable JIS C 3312 4 conductors</p> <p>88/0.45 (14mm²)</p> <p>24φ</p> <p>Crimp style terminals 14-5</p> <p>Crimp style terminals 14-6</p>	

Model	Symbol	Specifications	FANUC specification No.
15S (Lower than 30 kVA)	K1 K2	 <p data-bbox="494 482 1017 555">Crimp style terminal 14 - 8 88/0.45 (14 mm²) Crimp style terminal R14-6S</p>	
18S (Lower than 45 kVA)	K1 K2	<p data-bbox="632 614 879 643">Heat resisting vinyl cable</p>  <p data-bbox="494 787 1017 880">Crimp style terminal 20 - 8 (Note) 7/20/0.45 (22 mm²) Crimp style terminal 20 - 8</p>	
22S, 26S (Lower than 45 kVA)	K1 K2	<p data-bbox="632 953 879 982">Heat resisting vinyl cable</p>  <p data-bbox="494 1114 1017 1196">Crimp style terminal 30 - 8 7/27/0.45 (30 mm²) Crimp style terminal 30 - 8</p>	

Note) Use the flame retardant poli-flex cable (MLFC)
(Maximum temperature of conductor: 105°C)

2) Common line

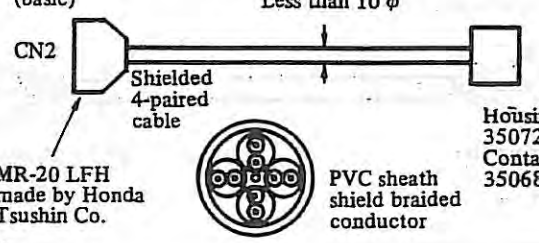
The following cables are common to each model.

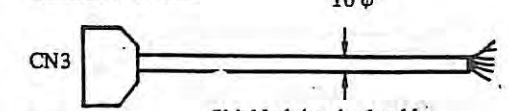
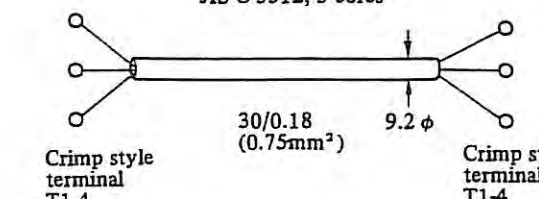
Model	Symbol	Specifications	FANUC specification No.
Spindle servo unit AC spindle motor (for signal)	K4	Spindle servo unit option connector (basic) Attached connector of spindle motor. Less than 10 φ  MR-20 LFH made by Honda Tsushin Co. Housing 350720-1 Contact 350689-1 PVC sheath shield braided conductor	A06B-6044-K200 7 m long
Spindle servo unit Power magnetic control (for signal)	K5	Spindle servo unit connector (basic) Power magnetic control 12.5 φ  MR-50 LFH made by Honda Tsushin Co. Braided shield vinyl cable 50 conductors x 0.2mm ² (7/0.18) made by Sanyo Denko.	A06B-6044-K023 7 m long
Spindle servo unit Power magnetic control (for signal)	K6	Spindle servo unit connector: (basic) 10 φ  MR-20 LMH made by Honda Tsushin Co. Shielded 4-paired cable 0.3 mm ²	A06B-6044-K024 7 m long
Speedmeter load meter AC spindle servo unit (for meter)	K7	Vinyl cabtyre cable JIS C 3312, 3 cores  Crimp style terminal T1-4 30/0.18 (0.75mm ²) 9.2 φ Crimp style terminal T1-4	

3) Others (line used in some models)

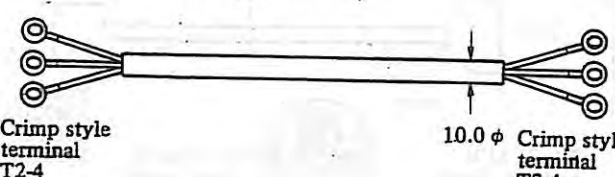
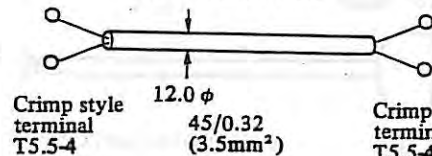
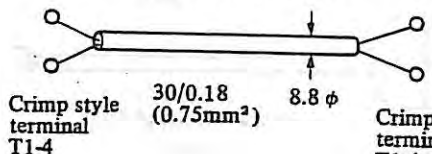
Model	Symbol	Specifications	FANUC specification No.
For motor cooling fan	K3	<p>Vinyl cabtyre cable JIS C 3312, 3 cores</p> <p>Conductor 37/0.26 (2mm²) Outer cover PVC ϕ10</p>  <p>Crimp style terminal T2-4</p> <p>10.0 ϕ Crimp style terminal T2-4</p>	
Resistor unit AC spindle servo unit (Model 1S - 3S)	K8	<p>Vinyl cabtyre cable JIS C 3312, 2 cores</p>  <p>Crimp style terminal T5.5-4</p> <p>12.0 ϕ</p> <p>45/0.32 (3.5mm²)</p> <p>Crimp style terminal T5.5-4</p>	
Resistor unit Power magnetic control (for thermostat) (Model 1S - 3S)	K9	<p>Vinyl cabtyre cable JIS C 3312, 2 cores</p>  <p>Crimp style terminal T1-4</p> <p>30/0.18 (0.75mm²)</p> <p>8.8 ϕ</p> <p>Crimp style terminal T1-4</p>	

APPENDIX 4 CONFIGURATION OF MAIN CIRCUIT

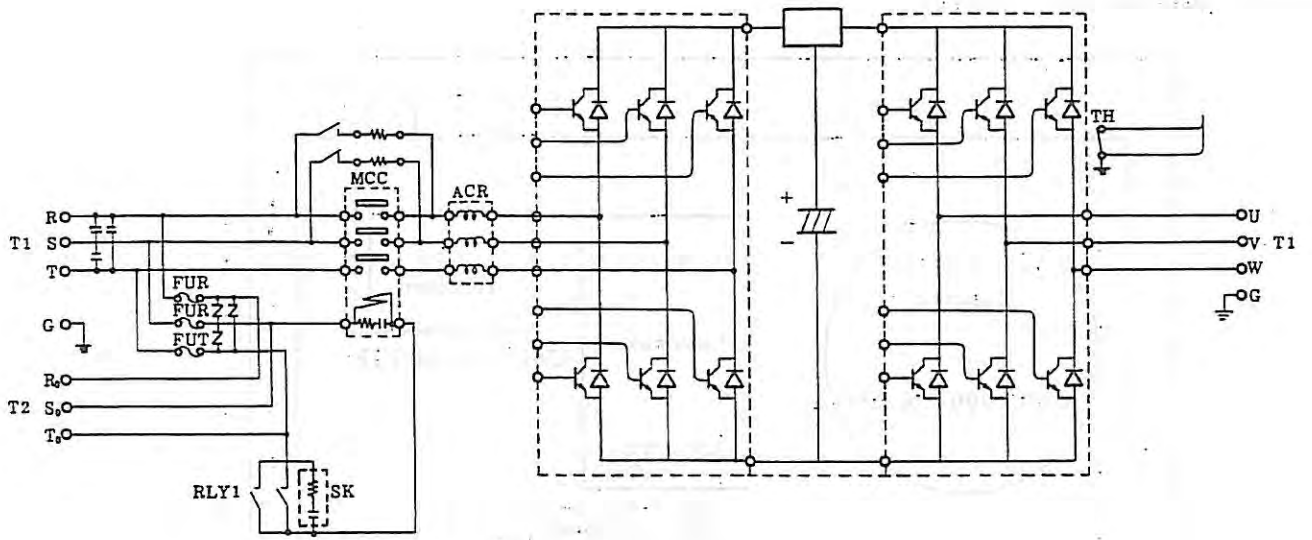

APPENDIX 5 LOCATION OF UNIT

1) Unit (models 1S - 3S)

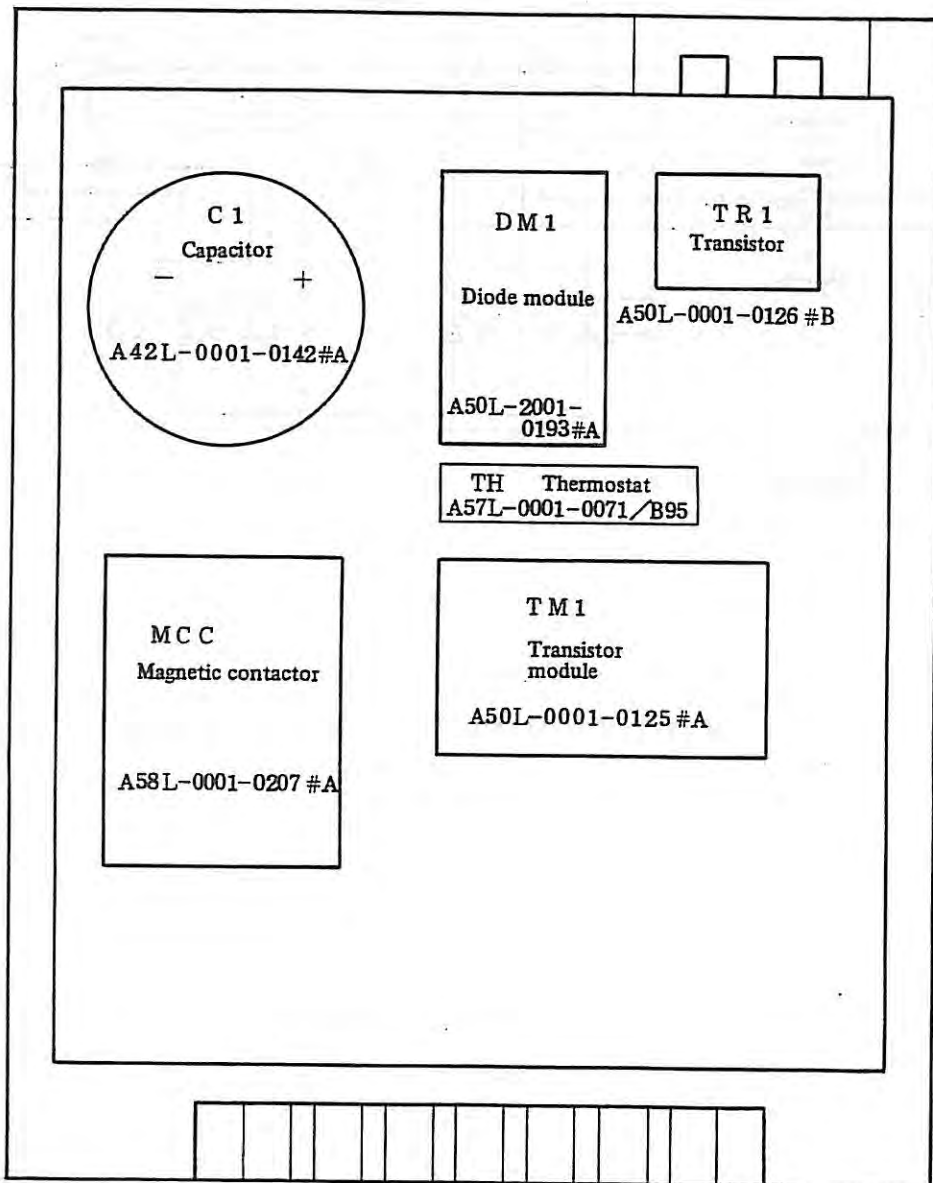

Heat sink A50L-6001-0347

Spindle control circuit PCB (PCB1): A16B-1100-0200
Control circuit PCB (PCB2) : A16B-1100-024□

See Fig. 2 (a) in Appendix 2.

2) Unit (models 6S - 12S)

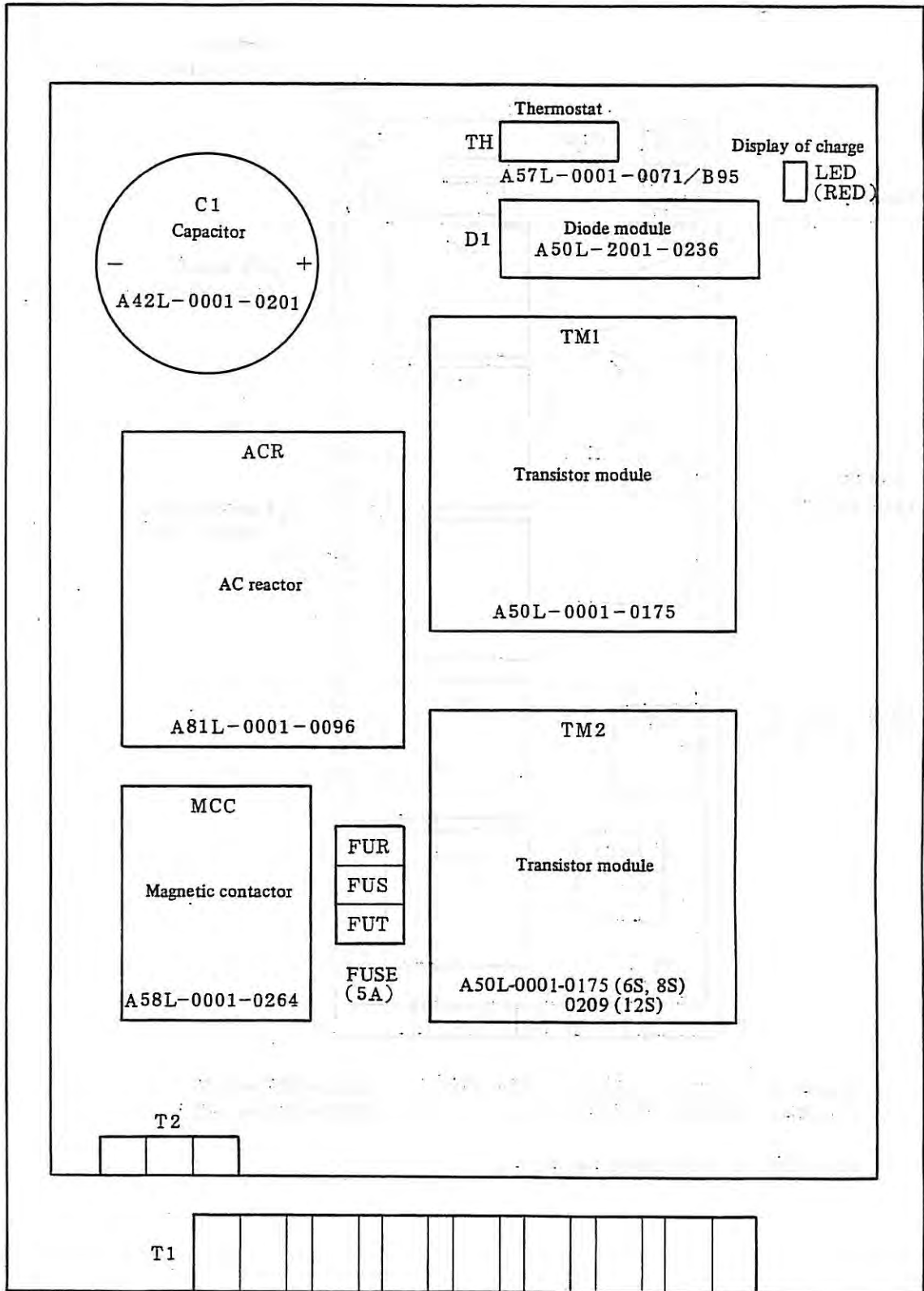

Spindle control circuit PCB (PCB1): A20B-1003-0010
 Control circuit PCB (PCB2) : A20B-1003-0020

See Fig. 2 (b) in Appendix 2.

3) Unit (models 15S - 22S)

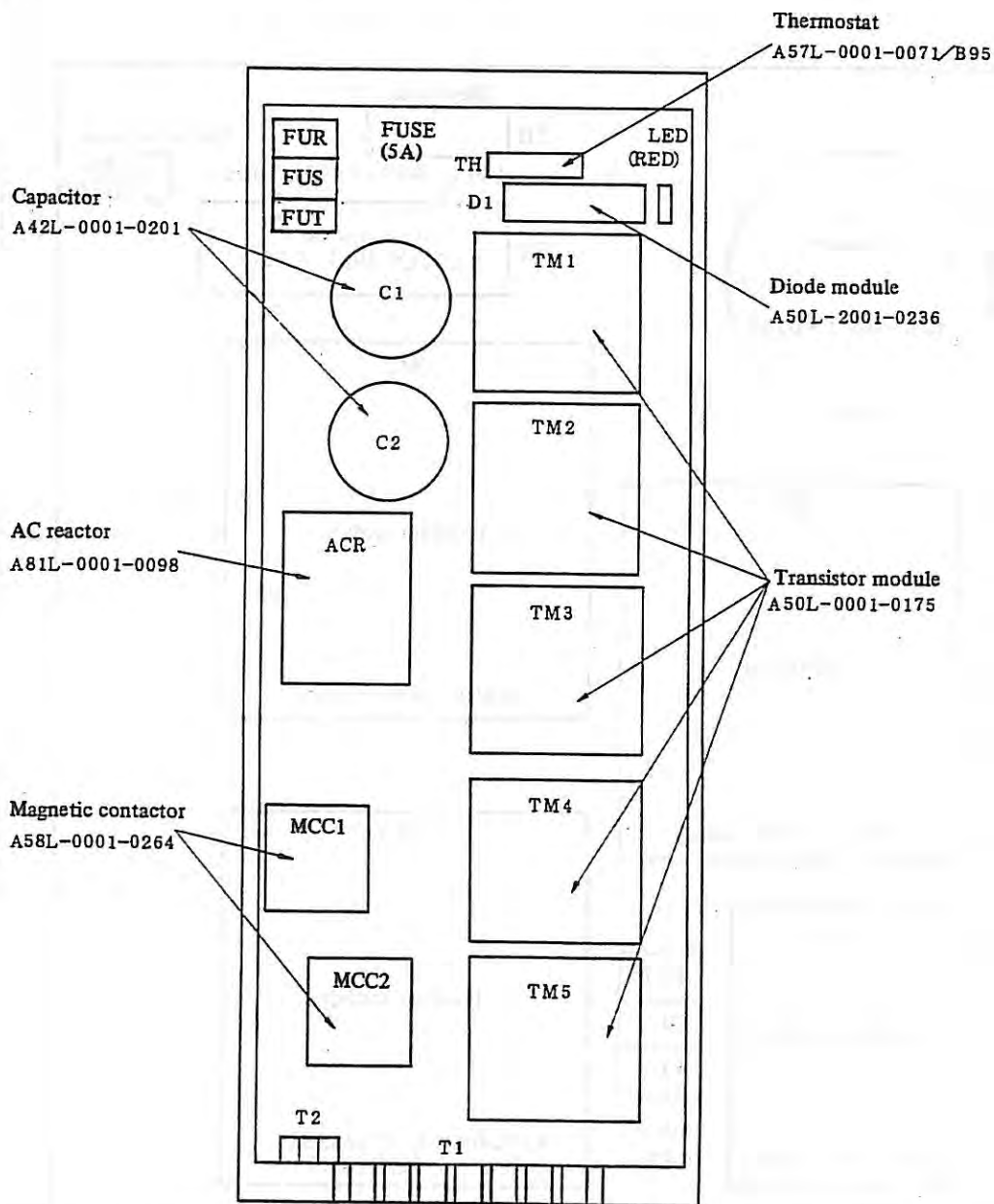

Spindle control circuit PCB (PCB1): A20B-1003-0010
 Control circuit PCB (PCB2) : A20B-1003-0120

See Fig. 2 (c) in Appendix 2.

4) Unit (models 26S)

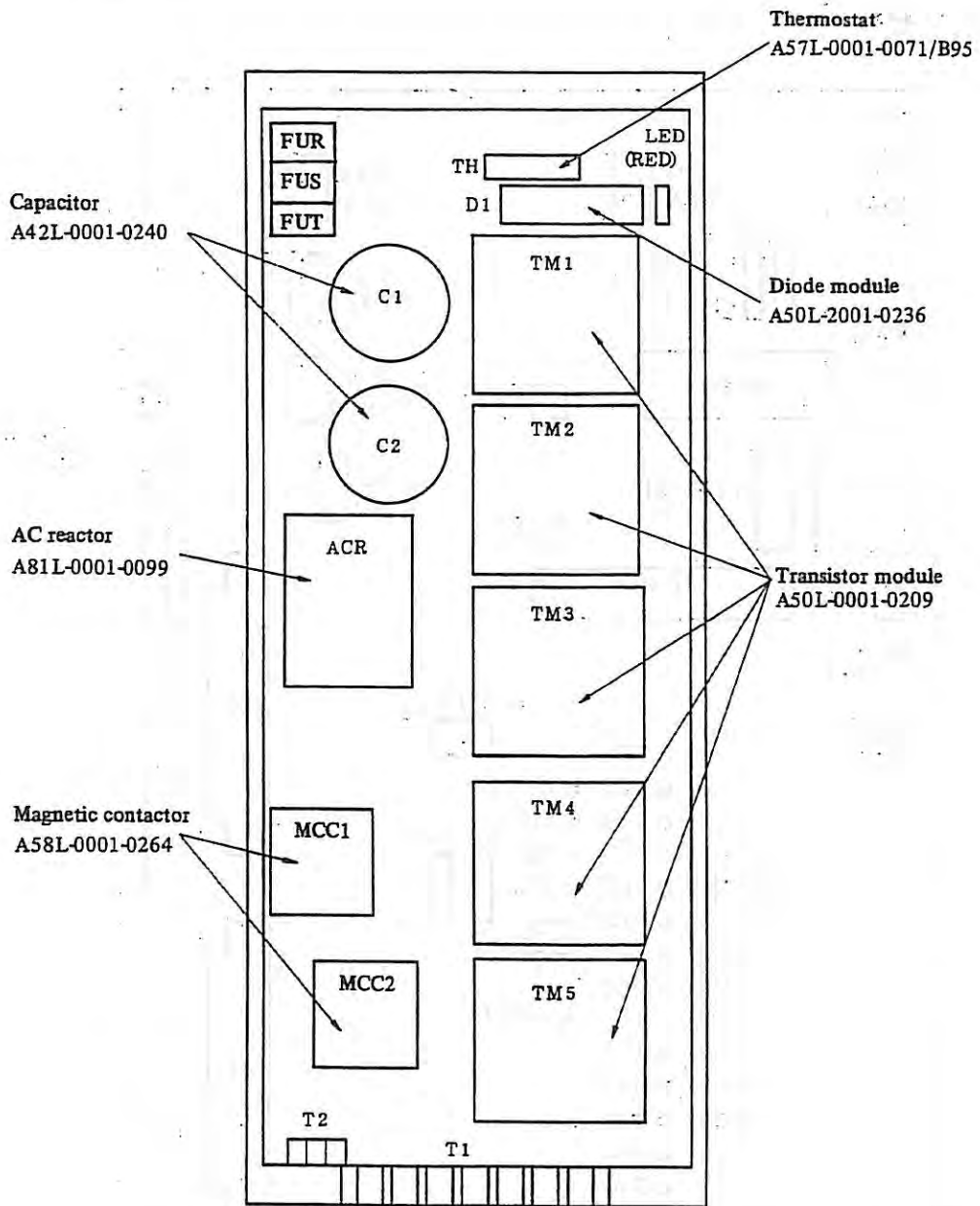

Spindle control circuit PCB (PCB1): A20B-1003-0010
 Control circuit PCB (PCB2): A20B-1003-0121

See Fig. 2 (c) in Appendix 2.

APPENDIX 6 LOCATION OF PCB

1) Models 1S - 3S

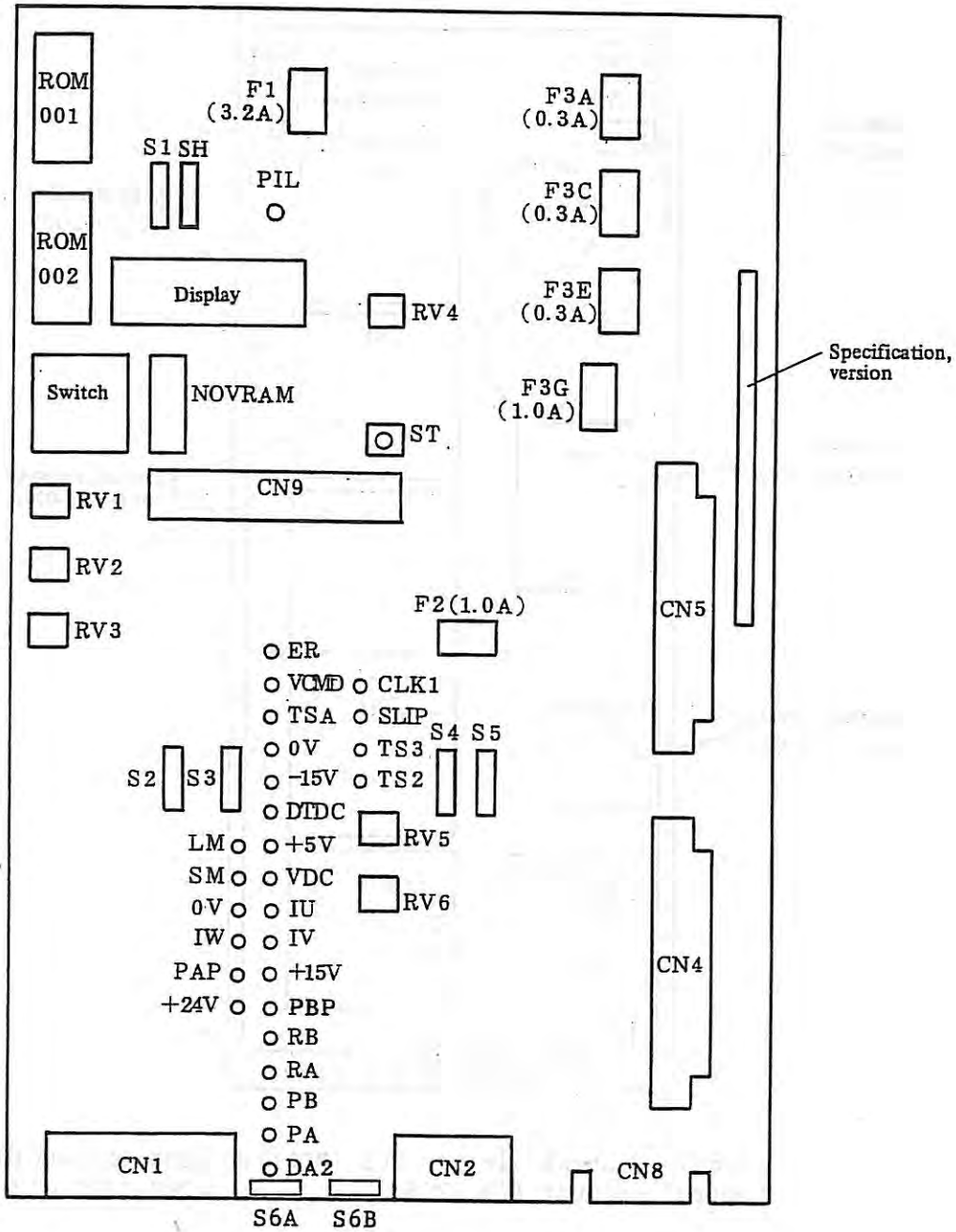

Note 1) SH applies from version 13B and later.

Note 2) S6A and S6B applies from version 21B and later.

2) Models 6S - 26S PCB version number 09A and earlier

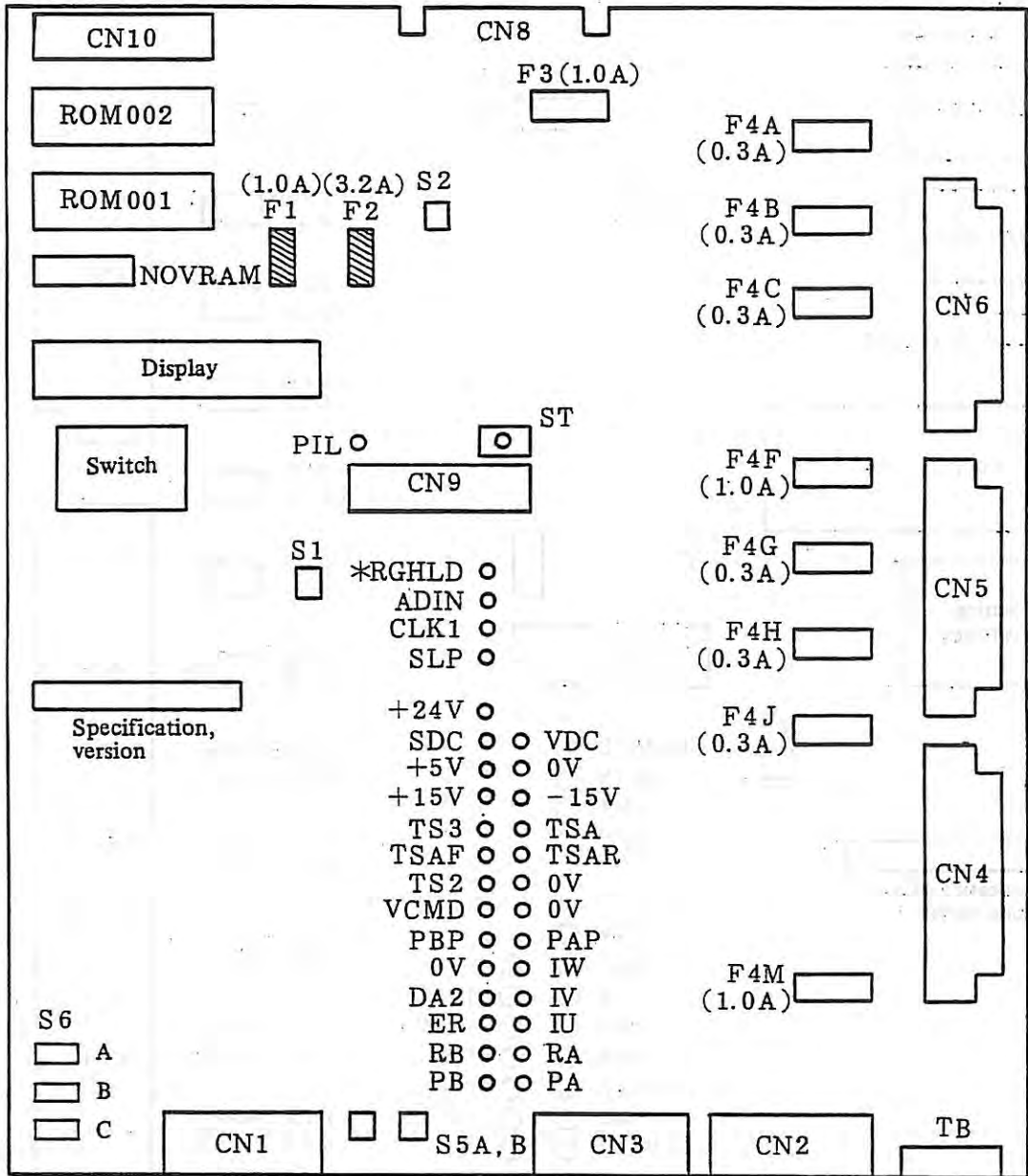

3) Models 6S - 26S PCB version number 10B and ~~earlier~~ *LAYER*

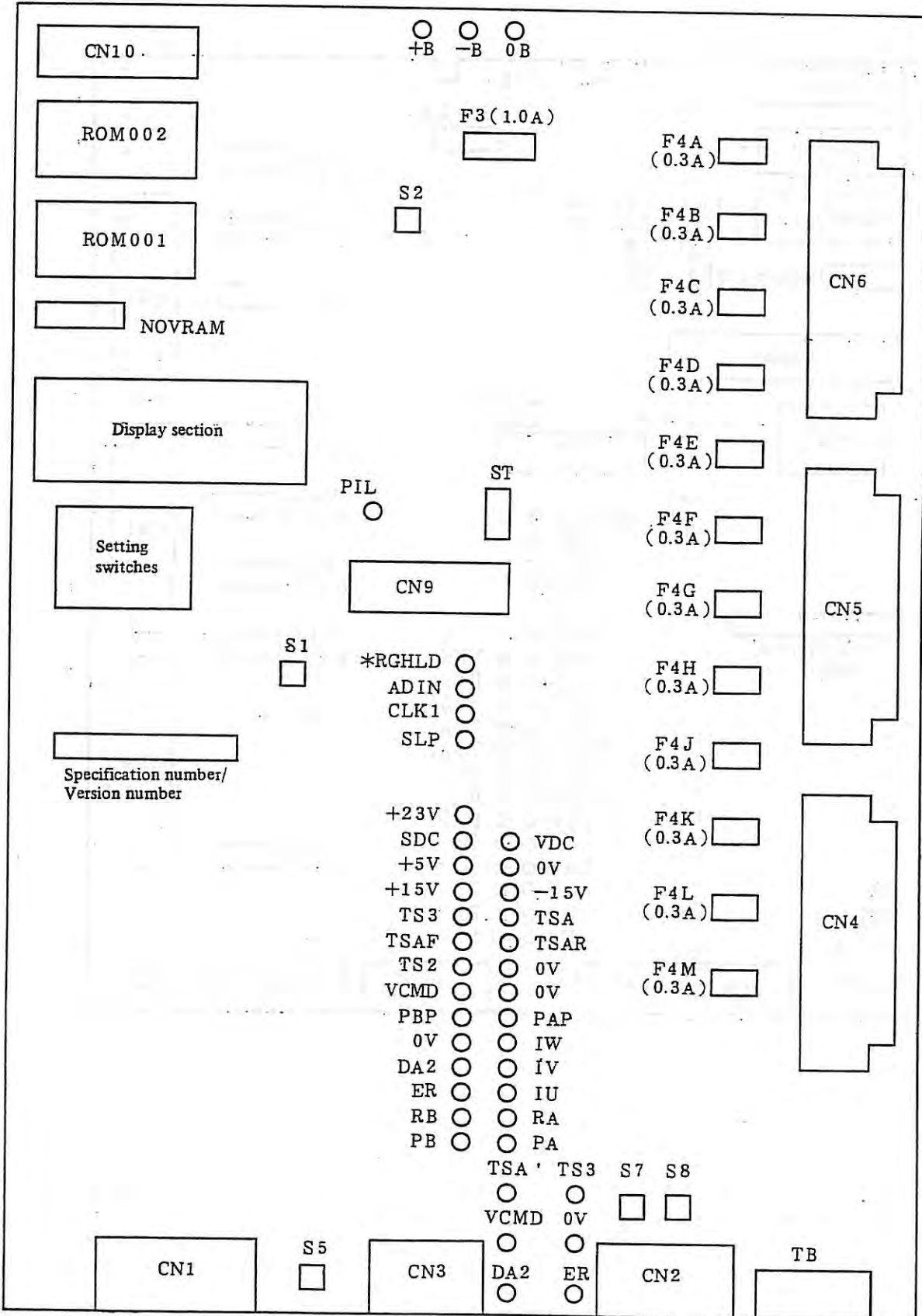

APPENDIX 7 MAJOR PARTS

1) Models 1S - 3S

Name	Symbol	Specifications	Remarks
Spindle control circuit PCB	PCB1	A16B-1100-0200	
Fuse	F1	A60L-0001-0175/3.2A	3.2A
	F2, F3G	A60L-0001-0175/1.0A	1.0A
	F3A, C, E	A60L-0001-0175/0.3A	0.3A
Control circuit PCB	PCB2	A16B-1100-024 □	
Transistor module	TM1	A50L-0001-0125#A	50A/600Vx6
Transistor	TR1	A50L-0001-0126#B	50A/600Vx1
Diode module	DM1	A50L-2001-0193#A	
Magnetic contactor	MCC	A58L-0001-0207#A	
Capacitor	C1	A42L-0001-0142#A	
Thermostat	TH	A57L-0001-0071/B95	
AC line filter		A81L-0001-0083/3C	option

2) Models 6S - 26S PCB version number 09A and earlier

Name	Symbol	Specifications	Remarks
Spindle control circuit PCB	PCB1	A20B-1003-0010	
Alarm fuse	F1	A60L-0001-0046/1.0	1.0A
	F2	A60L-0001-0046/3.2	3.2A
Fuse	F3, F4M, F4F	A60L-0001-0175/1.0A	1.0A
	F4A, B, C, G, H, J	A60L-0001-0175/0.3A	0.3A
Control circuit PCB	PCB2	A20B-1003-0020	Models 6S - 12S
		A20B-1003-0120	Models 15S - 22S
		A20B-1003-0121	Model 26S
Fuse	FUR, S, T	A60L-0001-0031/5A	5.0A
Transistor module	TM1 - 5	A50L-0001-0175	120A/600Vx6 (Models 6S - 22S)
		A50L-0001-0209	150A/600Vx6 (Model 26S)
Diode module	D1	A50L-2001-0236	
Magnetic contactor	MCC	A58L-0001-0264	
Capacitor	C1, 2	A42L-0001-0201	
Surge absorber		A50L-2001-0155/20D431	
Thermostat	TH	A57L-0001-0071/B95	
AC reactor	ACR	A81L-0001-0096	Models 6S - 12S
		A81L-0001-0098	Models 15S - 22S
		A81L-0001-0099	Model 26S
Terminal cover		A300-0001-X088	Models 6S - 26S (basic)

3) Models 6S - 26S PCB version number 10B and later

Name	Symbol	Specifications	Remarks
Spindle control circuit PCB	PCB1	A20B-1003-0010	
Alarm fuse		_____	
Fuse	F3	A60L-0001-0175/1.0A	1.0A
	F4A, B, C, D, E, F, G, H, J K, L, M	A60L-0001-0175/0.3A	0.3A
Control circuit PCB	PCB2	A20B-1003-0020	Models 6S - 12S
		A20B-1003-0120	Models 15S - 22S
		A20B-1003-0121	Model 26S
Fuse	FUR, S, T	A60L-0001-0031/5A	5.0A
Transistor module	TM1 - 5	A50L-0001-0175	120A/600Vx6 (Models 6S - 22S)
		A50L-0001-0209	150A/600Vx6 (Model 26S)
Diode module	D1	A50L-2001-0236	
Magnetic contactor	MCC	A58L-0001-0264	
Capacitor	C1, 2	A42L-0001-0201	
Surge absorber		A50L-2001-0155/ 20D431	
Thermostat	TH	A57L-0001-0071/B95	
AC reactor	ACR	A81L-0001-0096	Models 6S - 12S
		A81L-0001-0098	Models 15S - 22S
		A81L-0001-0099	Model 26S
Terminal cover		A300-0001-X088	Models 6S - 26S (basic)

APPENDIX 8 ADJUSTING AND SETTING PCB

The following shows the main adjustments and setting items.
Refer to chapter 5 for parameter settings and adjusting variable resistors.

1) Adjusting rotation speed

Adjust the rotation speed according to the following procedure.

No.	Item	Adjustment contents	Adjusting location
1	Adjusting speed detection offset	Adjust so that voltage of check terminal "TS3" becomes 0 \pm 1 mV in the motor stop (SFR/SRV:OFF) state.	Models 1S - 3S: RV3 (Refer to item 5.1) Models 6S - 26S: F-29 (Refer to item 5.3)
2	Adjusting speed error offset at forward rotation command	Adjust so that motor stops at speed zero command (VCMD:0V, SFR:OFF).	F-10 (Refer to item 5.3)
3	Adjusting speed error offset at reverse rotation command	Adjust so that motor stops at speed zero command (VCMD:0V, SRV:OFF).	F-11 (Refer to item 5.3)
4	Adjusting rotation speed at forward rotation command	Adjust so that rotation speed becomes as commanded at forward rotation command (SFR: ON)	Models 1S - 3S: RV1 (Refer to item 5.1) Models 6S - 26S: F-13 (Refer to item 5.3)
5	Adjusting rotation speed at back rotation command	Adjust so that rotation speed becomes as commanded at back rotation command (SRV:ON)	Models 1S - 3S: RV2 (Refer to item 5.1) Models 6S - 26S: F-14 (Refer to item 5.3)
6	Rotation speed setting at speed command voltage (VCMD) 10 V	Set the value of the rotation speed divided by 100 at speed command voltage (VCMD) 10 V	F-15 (Refer to item 5.3)

2) Setting speed arrival level

For the speed command, the contact turns ON (closed) if the actual motor rotation speed arrives within a certain preset range.

This signal is used as the check signal (FIN signal) for the rotation direction command (SFR/SRV).

Setting is performed by parameter F-16. (Refer to section 5.3)

3) Setting speed detection level

The contact turns ON (closed) if the motor rotation speed falls below the preset speed.

This signal is used for detecting that the clutch switchable speed or gear switchable speed, etc. has fallen below a certain preset speed.

Further, in output switching control it is used for the detection of the switching speed to switch the coil.

Setting is performed by parameter F-17. (Refer to section 5.3)

4) Setting speed zero detection level

For the stop command, the contact turns ON (closed) if the actual motor rotation speed falls below the detection point. This signal is used as the check signal (FIN signal) for the stop command. Setting is performed by parameter F-35. (Refer to section 5.3)

5) Setting load detection level

For the maximum detection level of the loadmeter, the contact turns ON (closed) if it rises above the preset value. This signal is used for the detection of load states such as wear of the cutting tool. Setting is performed by parameter F-36. (Refer to section 5.3)

APPENDIX 9. CHECK TERMINAL LIST

1) Models 1S - 3S

Name	Signal contents	Remarks
DA2	Analog speed command voltage	0 to +10V
PA	Pulse generator output A-phase	90° advance by PB at CW rotation Vp-p = 0.36 - 0.5 V
PB	Pulse generator output B-phase	90° delay by PA at CW rotation Vp-p = 0.36 - 0.5 V
RA	A-phase standard voltage	DC 2.5 V
RB	B-phase standard voltage	DC 2.5 V
PAP	A-phase square wave	Duty 50%
PBP	B-phase square wave	Duty 50%
TSA	Speed feedback signal	At maximum rated rotation +10 V (+10 V: CW, -10 V: CCW)
TS2	Low-speed detection signal	Adjustment of each model by RV6 (refer to item 5.1)
TS3	Speed pulse F/V signal	At CCW (forward rotation) 6,000 rpm, -4.65 to -6.15 V
VCMD	Speed command voltage	0 - +10 V (+10V: CCW, -10V: CW)
FWP	Forward rotation pulse	Pulse width = 3.2 μs, occurs only at CCW (forward rotation)
RVP	Backward rotation pulse	Pulse width = 3.2 μs, occurs only at CW (backward rotation)
ER	Error voltage	-4.2 to +4.8 W
CLK1	Clock signal	2.5 MHz, duty 50%
SLIP	Slip pulse	
VDC	DC link voltage signal	Voltage 1/100 of DC link voltage
DTDC	DC form voltage of input AC voltage	Voltage 1/100 of DC form voltage of input AC voltage
IU	U-phase current detection signal	Current value 22.2 A/V
IV	V-phase current detection signal	
IW	W-phase current detection signal	

Name	Signal contents	Remarks
+24	+ 24 V	Refer to section 4.1
+15	+15 V	
+5	+5 V	
-15	-15 V	
0V	0 V	
SM	Speed meter signal	At maximum rated rotation +10 V
LM	Loadmeter signal	At maximum rated output +10 V

2) Models 6S - 26S

Name	Signal contents	Remarks
DA2	Analog speed command voltage	0 - +10V
PA	Pulse generator output A-phase	90° advance by PB at CW rotation Vp-p = 0.36 - 0.5 V
PB	Pulse generator output B-phase	90° delay by PA at CW rotation Vp-p = 0.36 - 0.5 V
RA	A-phase standard voltage	DC 2.5 V
RB	B-phase standard voltage	DC 2.5 V
PAP	A-phase square wave	Duty 50%
PBP	B-phase square wave	Duty 50%
TSA	Speed feedback signal	At maximum rated rotation +10 V (+10 V: CW, -10 V: CCW)
TS2	Low-speed detection signal	At CCW (forward rotation) 22.5 rpm, -1.4 V <u>+0.3 V</u>
TS3	Speed pulse F/V signal	At CCW (forward rotation) 6,000 rpm, -4.65 to -6.15 V
VCMD	Speed command voltage	0 - <u>+10 V</u> (+10V: CCW, -10V: CW)
TSAF	Forward rotation speed detection signal	At CCW (forward rotation) 6,000 rpm, 0.82 V <u>+82 mV</u>
TSAR	Backward rotation speed detection signal	AT CW (backward rotation) 6,000 rpm, 0.82 V <u>+82 mV</u>
ER	Error voltage	-4.2 - +4.8 W

Name	Signal contents	Remarks								
CLK1	Clock signal	2.5 MHz, duty 50%								
SLP	Slip pulse									
VDC	DC link voltage signal	Voltage 1/100 of DC link voltage								
SDC	Control power DC link voltage	Voltage 1/100 of control power DC link voltage								
ADIN	AD converter input signal									
IU	U-phase current detection signal	<table border="1"> <thead> <tr> <th>Model</th> <th>6S-12S</th> <th>15S-22S</th> <th>26S</th> </tr> </thead> <tbody> <tr> <td>Current value</td> <td>33.3A/V</td> <td>66.6A/V</td> <td>83.3A/V</td> </tr> </tbody> </table>	Model	6S-12S	15S-22S	26S	Current value	33.3A/V	66.6A/V	83.3A/V
Model	6S-12S		15S-22S	26S						
Current value	33.3A/V		66.6A/V	83.3A/V						
IV	V-phase current detection signal									
IW	W-phase current detection signal									
+24	+24 V	Refer to section 4.1.								
+15	+15 V									
+5	+5 V									
-15	-15 V									
0V	0 V									
*RGHLD	Regenerative stop signal									

3) Waveform of Check Terminal.

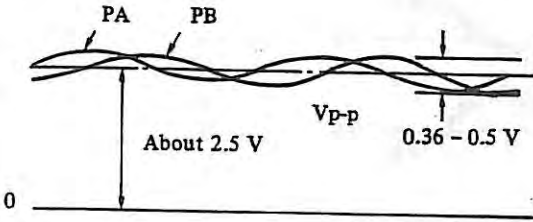
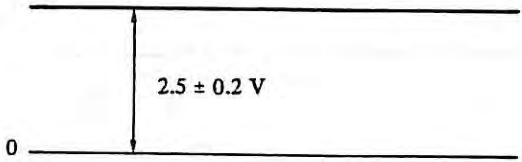
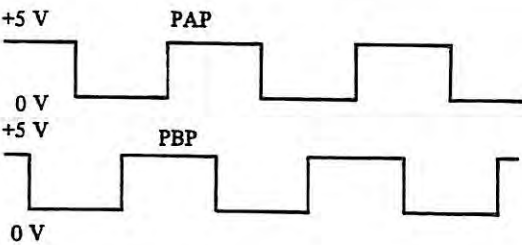
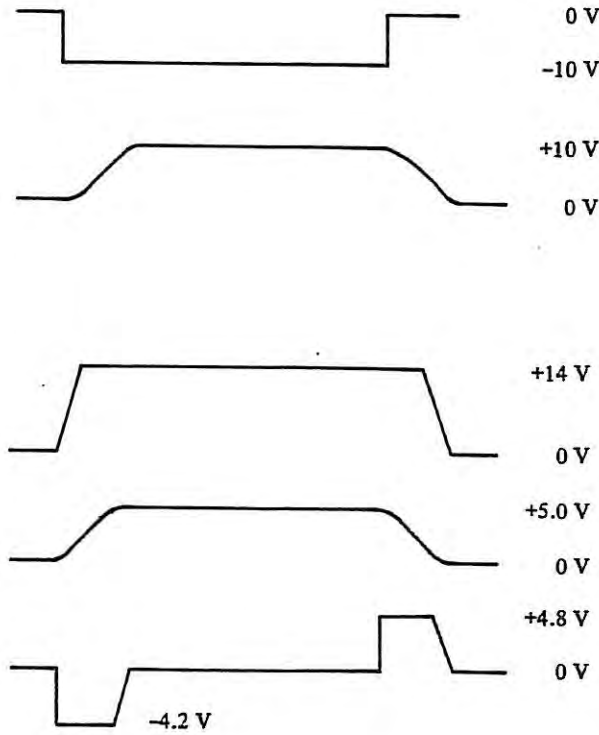
Check terminal	Waveform	Remarks
PA PB		
RA RB		
PAP PBP		
VCMD TSA TS2 TS3 ER		

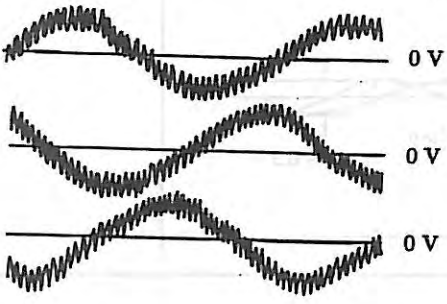
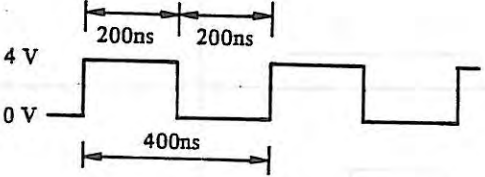
Check terminal	Waveform	Remarks
IU IV IW		
CLK1		2.5 MHz

APPENDIX 10 MAGNETIC SENSOR SIGNALS CHECKING METHOD

10.1 Application

This document applies to the following check procedure by observing output signals of the magnetic sensor (specification: A57L-0001-0037) employed for magnetic sensor system spindle orientation.

Object PCB diagram number A16B-1300-0110 - 1 Models 1S - 3S
 A20B-0008-0032 - 3 Models 6S - 26S
 A20B-0009-0521

Item	Check item
1	Whether magnetizer, magnetic sensor head, and magnetic sensor amplifier are defective or not.
2	Whether magnetizer and magnetic sensor head are properly mounted or not.
3	Whether magnetic sensor signal cables are properly connected without any connection failure and short-circuit.

10.2 Check Procedure

1) Preparation

- ① Rotate the spindle at about 120rpm. Select the counterclockwise rotating direction as viewed from the AC spindle motor shaft (in such a direction as the voltage at the test point (VCMD) of AC spindle control circuit PCB becomes positive against 0 V.
 Models 1S - 3S : A16B-1100-0200
 Models 6S - 26S: A20B-1003-0010
- ② Check the peak voltage and offset voltage levels of the following signal waveforms at the test points of the orientation circuit using an oscilloscope. The names of test points and signal contents are common, irrespective of the kinds of orientation circuit.

Test points	Signal name	Symbol	Prove common terminal
CH1	Magnetic sensor output signal A	MSA	0 V
CH2	Magnetic sensor output signal B	LSA	

2) Decision method

- ① Examples of normal waveforms and their criteria are as shown below. If a trouble occurred, refer to the causes and remedy shown in the following table.

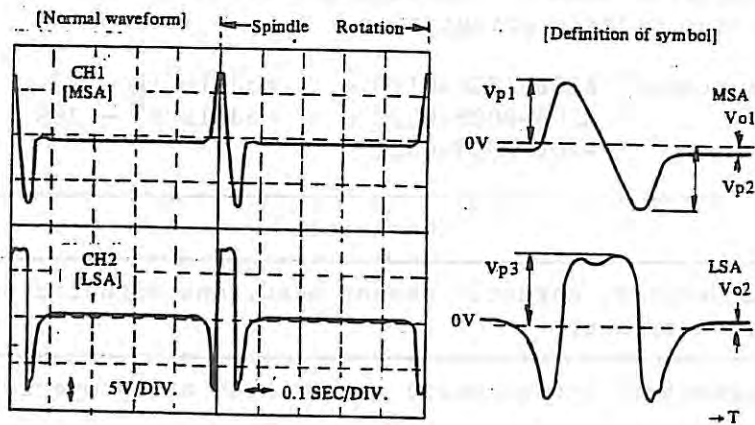

(Criteria table)

Item	Criteria (normal, if these conditions are satisfied.)
Offset voltage	$V_{o1\&2} < 0.5 \text{ V}$
Peak voltage	$3\text{V} < V_{p1\&2} < 10 \text{ V}$

- ② Remedy to be observed when the above criteria are not satisfied.

Item	Symptoms	Causes	Remedy
1	Offset voltage of either or both signals is high. Offset voltage is normal. Peak voltage of either signal only is low.	a. Magnetic sensor head or magnetic sensor amplifier is defective.	Replace defective parts.
2	Waveform of either signal does not appear, or waveforms of both signals don't appear.	a. Magnetic sensor head, amplifier, or magnetic sensor amplifier is defective. b. Poor connection or short-circuit of cables or connectors.	a. Replace defective parts. b. Repair defective parts.
3	Offset voltage is normal, but the entire peak voltage is low.	a. Mounting gap of the magnetic sensor head and the magnetizer is wider than specified.	Readjust the gap.

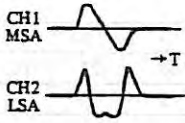
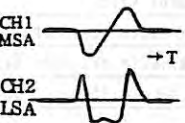
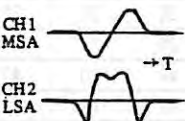
Item	Symptoms	Causes	Remedy
4	Offset voltage and peak voltage levels are normal, but waveforms are different from specified ones.	Observe the following procedure according to waveforms.	
Observation waveform		a. Magnetic sensor head is not mounted properly. b. Wrong cable connection.	a. Reverse the pin groove direction of the magnetic sensor head. b. Replace LSA and LSB with each other.
		a. Magnetizer is not properly mounted. b. Wrong cable connection.	a. Reverse the direction of the reference hole of magnetizer. b. Replace MSA and MSB with each other. Replace LSA and LSB with each other.
		a. Magnetizer and magnetic sensor head are not properly mounted. b. Wrong cable connection.	a. Reverse the mounting directions of both magnetizer and magnetic sensor head. b. Replace MSA and MSB with each other.

Reference) For normal mounting methods and connection methods of signal cables of the magnetizer and magnetic sensor head, refer to 7.3.1 in text and appendix 1 "Connections".

APPENDIX 11 PARAMETER LIST

PARAMETER TABLE FOR AC SPINDLE SERVO UNIT S series (F-00 ~ 53)

(1/11)

F-	CONTENTS OF PARAMETER	MODEL	1S	2S	3S	2H	1.5S	1H	3S 8000		
		SERIES · EDITION	9801G	9802H	9803G	9805F	9808F	9809E	9810E		
		UNIT	H002	H002	H003	H002	H002	H002	H003		
00	MOTOR SPEED INDICATION										
01	USE/NO USE OF THE MACHINE READY SIGNAL(MRDY)		1	1	1	1	1	1	1		
02	USE/NO USE OF SPEED OVERRIDE FUNCTION										
03	OVERRIDE RANGE SETTING										
04	MOTOR SPEED INDICATION										
05	SETTING OF MAXIMUM ROTATION SPEED										
06	OUTPUT POWER LIMIT PATTERN SETTING		0	0	0	0	0	0	0		
07	SETTING OF LIMIT VALUE AT OUTPUT POWER LIMIT		100	100	100	100	100	100	100		
08	DELAY TIME BEFORE CUTTING MOTOR POWER SUPPLY		5	5	5	5	5	5	5		
09	USE/NO USE OF MOTOR POWER SUPPLY CUT-OFF BY MRDY		0	0	0	0	0	0	0		
10	VELOCITY DEVIATION OFFSET ADJUSTMENT AT SFR		Adjustment value								
11	VELOCITY DEVIATION OFFSET ADJUSTMENT AT SRV		Adjustment value								
12	VELOCITY DEVIATION OFFSET ADJUSTMENT AT ORCM		Adjustment value								
13	ROTATION SPEED ADJUSTMENT AT SFR		Adjustment in variable resistor RV1								
14	ROTATION SPEED ADJUSTMENT AT SRV		Adjustment in variable resistor RV2								
15	SETTING OF ROTATION SPEED AT VELOCITY COMMAND, 10V		80	80	60	150	80	150	80		
16	DETECTION RANGE OF SPEED ARRIVAL SIGNAL(SAR)		15	15	15	15	15	15	15		
17	DETECTION RANGE OF SPEED DETECTION SIGNAL(SDT)		3	3	3	3	3	3	3		
18	SETTING OF TORQUE LIMIT VALUE		50	50	50	50	50	50	50		
19	SETTING OF ACCELERATION/DECELERATION TIME		10	10	10	20	10	20	10		
20	LIMITING OF REGENERATING POWER(ADJ. OF DEC. TIME)		40	40	40	40	40	40	40		
21	VELOCITY LOOP P GAIN :HIGH GEAR(CTH=1)		20	20	20	20	20	20	20		
22	VELOCITY LOOP P GAIN :LOW GEAR(CTH=0)		20	20	20	20	20	20	20		
23	VELOCITY LOOP P GAIN AT ORIENTATION:HIGH GEAR		40	40	40	40	40	40	40		
24	VELOCITY LOOP P GAIN AT ORIENTATION:LOW GEAR		40	40	40	40	40	40	40		
25	VELOCITY LOOP I GAIN :HIGH GEAR(CTH=1)		10	10	10	10	10	10	10		
26	VELOCITY LOOP I GAIN :LOW GEAR(CTH=0)		10	10	10	10	10	10	10		
27	VELOCITY LOOP I GAIN AT ORIENTATION:HIGH GEAR		10	10	10	10	10	10	10		
28	VELOCITY LOOP I GAIN AT ORIENTATION:LOW GEAR		10	10	10	10	10	10	10		
29	ADJUSTMENT OF VELOCITY DETECTION OFFSET		Adjustment in variable resistor RV3								
30	MOTOR SPEED INDICATION										
31	SETTING OF RIGID TAP MODE		0	0	0	0	0	0	0		
32	SETTING OF MOTOR VOLTAGE AT NORMAL OPERATION		10	10	10	10	10	10	10		
33	SETTING OF MOTOR VOLTAGE AT ORIENTATION		10	10	10	10	10	10	10		
34	SETTING OF MOTOR VOLTAGE AT RIGID TAP MODE		100	100	100	100	100	100	100		
35	SETTING OF SPEED ZERO (SST) DETECTION LEVEL		75	75	75	75	75	75	75		
36	SETTING OF LOAD DETECTION LEVEL(LDT)		90	90	90	90	90	90	90		
37	TIME CONSTANT OF TORQUE DEVIATION AT DEC. START		0	0	0	0	0	0	0		
38	CHARACTERISTICS OF CONTROL IN DECELERATION		0	0	0	0	0	0	0		
39	CHAR. OF CONTROL IN STABLE ROTATION WITH NO LOAD		0	0	0	0	0	0	0		
40	CHARACTERISTICS OF CONTROL IN TORQUE LIMITATION		0	0	0	0	0	0	0		
41	CURRENT LOOP I GAIN		64	64	64	64	64	64	64		
42	SLIP COMPENSATION CONSTANT		10	10	10	10	10	10	10		
43	SLIP CONSTANT		11	22	32	20	11	11	32		
44	VOLTAGE COMPENSATION		10	10	10	10	10	10	10		
45	PWM MAXIMUM AMPLITUDE		5	5	5	5	5	5	5		
46	SECONDARY CURRENT CONSTANT		16	24	28	16	32	21	28		
47	CURRENT ESTIMATION CONSTANT		8	8	8	10	8	8	8		
48	CONSTANT TORQUE POINT		58	40	68	58	50	64	68		
49	EXCITATION WEAKENING POINT		61	46	56	48	48	64	56		
50	VOLTAGE CONVERSION CONSTANT		66	100	75	91	94	69	75		
51	GEAR = 128 : 1, 256 : 2		1	1	1	1	1	1	1		
52	CURRENT CONVERSION CONSTANT		68	115	118	139	112	68	118		
53	CURRENT LOOP P GAIN		30	20	20	12	30	30	20		

PARAMETER TABLE FOR AC SPINDLE SERVO UNIT S series (F-00 ~ 53)

(2/11)

F-	CONTENTS OF PARAMETER	MODEL	6S	8S	8S/ 6000	12S	12S/ 6000	15S	15S/ 6000	18S	18S/ 6000
		SERIES · EDITION	9811D	9812F	9813F	9814E	9815E	9816C	9817C	9818B	9819B
		UNIT	H206	H208	H208	H212	H212	H215	H215	H218	H218
00	MOTOR SPEED INDICATION										
01	USE/NO USE OF THE MACHINE READY SIGNAL(MRDY)	1	1	1	1	1	1	1	1	1	1
02	USE/NO USE OF SPEED OVERRIDE FUNCTION	1	1	1	1	1	1	1	1	1	1
03	OVERRIDE RANGE SETTING	1	1	1	1	1	1	1	1	1	1
04	MOTOR SPEED INDICATION										
05	SETTING OF MAXIMUM ROTATION SPEED	1	0	1	0	1	0	1	0	1	1
06	OUTPUT POWER LIMIT PATTERN SETTING	0	0	0	0	0	0	0	0	0	0
07	SETTING OF LIMIT VALUE AT OUTPUT POWER LIMIT	100	100	100	100	100	100	100	100	100	100
08	DELAY TIME BEFORE CUTTING MOTOR POWER SUPPLY	5	5	5	5	5	5	5	5	5	5
09	USE/NO USE OF MOTOR POWER SUPPLY CUT-OFF BY MRDY	0	0	0	0	0	0	0	0	0	0
10	VELOCITY DEVIATION OFFSET ADJUSTMENT AT SFR	Adjustment value									
11	VELOCITY DEVIATION OFFSET ADJUSTMENT AT SRV	Adjustment value									
12	VELOCITY DEVIATION OFFSET ADJUSTMENT AT ORCM	Adjustment value									
13	ROTATION SPEED ADJUSTMENT AT SFR	Adjustment value									
14	ROTATION SPEED ADJUSTMENT AT SRV	Adjustment value									
15	SETTING OF ROTATION SPEED AT VELOCITY COMMAND, 10V	60	45	60	45	60	45	60	45	60	45
16	DETECTION RANGE OF SPEED ARRIVAL SIGNAL(SAR)	15	15	15	15	15	15	15	15	15	15
17	DETECTION RANGE OF SPEED DETECTION SIGNAL(SDT)	3	3	3	3	3	3	3	3	3	3
18	SETTING OF TORQUE LIMIT VALUE	50	50	50	50	50	50	50	50	50	50
19	SETTING OF ACCELERATION/DECELERATION TIME	10	10	10	10	10	10	10	10	10	10
20	LIMITING OF REGENERATING POWER(ADJ. OF DEC. TIME)	40	40	40	40	40	40	40	40	40	40
21	VELOCITY LOOP P GAIN :HIGH GEAR(CTH=1)	50	50	50	50	50	50	50	50	50	50
22	VELOCITY LOOP P GAIN :LOW GEAR(CTH=0)	50	50	50	50	50	50	50	50	50	50
23	VELOCITY LOOP P GAIN AT ORIENTATION:HIGH GEAR	100	100	100	100	100	100	100	100	100	100
24	VELOCITY LOOP P GAIN AT ORIENTATION:LOW GEAR	100	100	100	100	100	100	100	100	100	100
25	VELOCITY LOOP I GAIN :HIGH GEAR(CTH=1)	30	30	30	30	30	30	30	30	30	30
26	VELOCITY LOOP I GAIN :LOW GEAR(CTH=0)	30	30	30	30	30	30	30	30	30	30
27	VELOCITY LOOP I GAIN AT ORIENTATION:HIGH GEAR	30	30	30	30	30	30	30	30	30	30
28	VELOCITY LOOP I GAIN AT ORIENTATION:LOW GEAR	30	30	30	30	30	30	30	30	30	30
29	ADJUSTMENT OF VELOCITY DETECTION OFFSET	Adjustment value									
30	MOTOR SPEED INDICATION										
31	SETTING OF RIGID TAP MODE	0	0	0	0	0	0	0	0	0	0
32	SETTING OF MOTOR VOLTAGE AT NORMAL OPERATION	10	10	10	10	10	10	10	10	10	10
33	SETTING OF MOTOR VOLTAGE AT ORIENTATION	10	10	10	10	10	10	10	10	10	10
34	SETTING OF MOTOR VOLTAGE AT RIGID TAP MODE	100	100	100	100	100	100	100	100	100	100
35	SETTING OF SPEED ZERO (SST) DETECTION LEVEL	75	75	75	75	75	75	75	75	75	75
36	SETTING OF LOAD DETECTION LEVEL(LDT)	90	90	90	90	90	90	90	90	90	90
37	TIME CONSTANT OF TORQUE DEVIATION AT DEC. START	0	0	0	0	0	0	0	0	0	0
38	CHARACTERISTICS OF CONTROL IN DECELERATION	0	0	0	0	0	0	0	0	0	0
39	CHAR. OF CONTROL IN STABLE ROTATION WITH NO LOAD	0	0	0	0	0	0	0	0	0	0
40	CHARACTERISTICS OF CONTROL IN TORQUE LIMITATION	0	0	0	0	0	0	0	0	0	0
41	CURRENT LOOP I GAIN	64	64	64	64	64	64	64	64	64	64
42	SLIP COMPENSATION CONSTANT	24	10	10	10	10	15	15	22	22	22
43	SLIP CONSTANT	20	16	16	38	38	40	40	36	36	36
44	VOLTAGE COMPENSATION	10	10	10	10	10	10	10	10	10	10
45	PWM MAXIMUM AMPLITUDE	5	5	5	5	5	8	8	8	8	8
46	SECONDALY CURRENT CONSTANT	42	30	30	36	36	47	47	36	36	36
47	CURRENT ESTIMATION CONSTANT	8	8	8	8	8	8	8	8	8	8
48	CONSTANT TORQUE POINT	64	71	71	71	71	71	71	65	65	65
49	EXCITATION WEAKENING POINT	64	56	56	60	60	55	55	63	63	63
50	VOLTAGE CONVERSION CONSTANT	63	73	73	88	88	71	71	69	69	69
51	GEAR = 128 : 1 , 256 : 2	2	2	2	2	2	2	2	2	2	2
52	CURRENT CONVERSION CONSTANT	88	127	127	122	122	82	82	122	122	122
53	CURRENT LOOP P GAIN	20	11	11	11	11	20	20	12	12	12

F-	CONTENTS OF PARAMETER	MODEL	22S	22S/ 6000		6S/A3	12/A8	12S/A8 6000			
		SERIES - EDITION	9820B	9821B	9822	9823C	9824C	9825C	9826	9827	9828
		UNIT	H222	H222		H203	H208	H208			
00	MOTOR SPEED INDICATION										
01	USE/NO USE OF THE MACHINE READY SIGNAL(MRDY)		1	1		1	1	1			
02	USE/NO USE OF SPEED OVERRIDE FUNCTION		1	1		1	1	1			
03	OVERRIDE RANGE SETTING		1	1		1	1	1			
04	MOTOR SPEED INDICATION										
05	SETTING OF MAXIMUM ROTATION SPEED		0	1		1	0	1			
06	OUTPUT POWER LIMIT PATTERN SETTING		0	0		0	0	0			
07	SETTING OF LIMIT VALUE AT OUTPUT POWER LIMIT		100	100		100	100	100			
08	DELAY TIME BEFORE CUTTING MOTOR POWER SUPPLY		5	5		5	5	5			
09	USE/NO USE OF MOTOR POWER SUPPLY CUT-OFF BY MRDY		0	0		0	0	0			
10	VELOCITY DEVIATION OFFSET ADJUSTMENT AT SFR					Adjustment value					
11	VELOCITY DEVIATION OFFSET ADJUSTMENT AT SRV					Adjustment value					
12	VELOCITY DEVIATION OFFSET ADJUSTMENT AT ORCM					Adjustment value					
13	ROTATION SPEED ADJUSTMENT AT SFR					Adjustment value					
14	ROTATION SPEED ADJUSTMENT AT SRV					Adjustment value					
15	SETTING OF ROTATION SPEED AT VELOCITY COMMAND.10V		45	60		60	45	60			
16	DETECTION RANGE OF SPEED ARRIVAL SIGNAL(SAR)		15	15		15	15	15			
17	DETECTION RANGE OF SPEED DETECTION SIGNAL(SDT)		3	3		3	3	3			
18	SETTING OF TORQUE LIMIT VALUE		50	50		50	50	50			
19	SETTING OF ACCELERATION/DECELERATION TIME		10	10		10	10	10			
20	LIMITING OF REGENERATING POWER(ADJ. OF DEC. TIME)		40	40		40	40	40			
21	VELOCITY LOOP P GAIN :HIGH GEAR(CTH=1)		50	50		50	50	50			
22	VELOCITY LOOP P GAIN :LOW GEAR(CTH=0)		50	50		50	50	50			
23	VELOCITY LOOP P GAIN AT ORIENTATION:HIGH GEAR		100	100		100	100	100			
24	VELOCITY LOOP P GAIN AT ORIENTATION:LOW GEAR		100	100		100	100	100			
25	VELOCITY LOOP I GAIN :HIGH GEAR(CTH=1)		30	30		30	30	30			
26	VELOCITY LOOP I GAIN :LOW GEAR(CTH=0)		30	30		30	30	30			
27	VELOCITY LOOP I GAIN AT ORIENTATION:HIGH GEAR		30	30		30	30	30			
28	VELOCITY LOOP I GAIN AT ORIENTATION:LOW GEAR		30	30		30	30	30			
29	ADJUSTMENT OF VELOCITY DETECTION OFFSET					Adjustment value					
30	MOTOR SPEED INDICATION										
31	SETTING OF RIGID TAP MODE		0	0		0	0	0			
32	SETTING OF MOTOR VOLTAGE AT NORMAL OPERATION		10	10		10	10	10			
33	SETTING OF MOTOR VOLTAGE AT ORIENTATION		10	10		10	10	10			
34	SETTING OF MOTOR VOLTAGE AT RIGID TAP MODE		100	100		100	100	100			
35	SETTING OF SPEED ZERO (SST) DETECTION LEVEL		75	75		75	75	75			
36	SETTING OF LOAD DETECTION LEVEL(LDT)		90	90		90	90	90			
37	TIME CONSTANT OF TORQUE DEVIATION AT DEC. START		0	0		0	0	0			
38	CHARACTERISTICS OF CONTROL IN DECELERATION		0	0		0	0	0			
39	CHAR. OF CONTROL IN STABLE ROTATION WITH NO LOAD		0	0		0	0	0			
40	CHARACTERISTICS OF CONTROL IN TORQUE LIMITATION		0	0		0	0	0			
41	CURRENT LOOP I GAIN		64	64		64	64	64			
42	SLIP COMPENSATION CONSTANT		22	22		24	10	10			
43	SLIP CONSTANT		32	32		19	33	33			
44	VOLTAGE COMPENSATION		10	10		10	10	10			
45	PWM MAXIMUM AMPLITUDE		8	8		5	5	5			
46	SECONDALY CURRENT CONSTANT		42	42		24	30	30			
47	CURRENT ESTIMATION CONSTANT		8	8		8	8	8			
48	CONSTANT TORQUE POINT		65	65		71	71	71			
49	EXICITATION WEAKENING POINT		63	63		64	60	60			
50	VOLTAGE CONVERSION CONSTANT		69	69		63	88	88			
51	GEAR = 128 : 1 , 256 : 2		2	2		2	2	2			
52	CURRENT CONVERSION CONSTANT		122	122		88	122	122			
53	CURRENT LOOP P GAIN		12	12		20	16	16			

PARAMETER TABLE FOR AC SPINDLE SERVO UNIT S series (F-00 ~ 53)

(4/11)

F-	CONTENTS OF PARAMETER	MODEL					3S/ 12000	6S/ 12000	8S/ 8000	12S/ 8000	15S/ 8000
		SERIES • EDITION	9829	9830	9831	9832	9833B	9834B	9835C	9836B	9837B
		UNIT					H206	H208	H212	H212	H215
00	MOTOR SPEED INDICATION										
01	USE/NO USE OF THE MACHINE READY SIGNAL(MRDY)					1	1	1	1	1	
02	USE/NO USE OF SPEED OVERRIDE FUNCTION					1	1	1	1	1	
03	OVERRIDE RANGE SETTING					1	1	1	1	1	
04	MOTOR SPEED INDICATION										
05	SETTING OF MAXIMUM ROTATION SPEED					1	1	2	2	2	
06	OUTPUT POWER LIMIT PATTERN SETTING					0	0	0	0	0	
07	SETTING OF LIMIT VALUE AT OUTPUT POWER LIMIT					100	100	100	100	100	
08	DELAY TIME BEFORE CUTTING MOTOR POWER SUPPLY					5	5	5	5	5	
09	USE/NO USE OF MOTOR POWER SUPPLY CUT-OFF BY MRDY					0	0	0	0	0	
10	VELOCITY DEVIATION OFFSET ADJUSTMENT AT SFR					Adjustment value					
11	VELOCITY DEVIATION OFFSET ADJUSTMENT AT SRV					Adjustment value					
12	VELOCITY DEVIATION OFFSET ADJUSTMENT AT ORCM					Adjustment value					
13	ROTATION SPEED ADJUSTMENT AT SFR					Adjustment value					
14	ROTATION SPEED ADJUSTMENT AT SRV					Adjustment value					
15	SETTING OF ROTATION SPEED AT VELOCITY COMMAND, 10V					120	120	80	80	80	
16	DETECTION RANGE OF SPEED ARRIVAL SIGNAL(SAR)					15	15	15	15	15	
17	DETECTION RANGE OF SPEED DETECTION SIGNAL(SDT)					3	3	3	3	3	
18	SETTING OF TORQUE LIMIT VALUE					50	50	50	50	50	
19	SETTING OF ACCELERATION/DECELERATION TIME					20	10	15	10	10	
20	LIMITING OF REGENERATING POWER(ADJ. OF DEC. TIME)					60	40	40	40	40	
21	VELOCITY LOOP P GAIN :HIGH GEAR(CTH=1)					40	100	50	50	50	
22	VELOCITY LOOP P GAIN :LOW GEAR(CTH=0)					40	100	50	50	50	
23	VELOCITY LOOP P GAIN AT ORIENTATION:HIGH GEAR					80	200	133	100	100	
24	VELOCITY LOOP P GAIN AT ORIENTATION:LOW GEAR					80	200	133	100	100	
25	VELOCITY LOOP I GAIN :HIGH GEAR(CTH=1)					40	60	40	40	40	
26	VELOCITY LOOP I GAIN :LOW GEAR(CTH=0)					40	60	40	40	40	
27	VELOCITY LOOP I GAIN AT ORIENTATION:HIGH GEAR					40	60	30	40	40	
28	VELOCITY LOOP I GAIN AT ORIENTATION:LOW GEAR					40	60	30	40	40	
29	ADJUSTMENT OF VELOCITY DETECTION OFFSET					Adjustment value					
30	MOTOR SPEED INDICATION										
31	SETTING OF RIGID TAP MODE					0	0	0	0	0	
32	SETTING OF MOTOR VOLTAGE AT NORMAL OPERATION					7	7	10	10	10	
33	SETTING OF MOTOR VOLTAGE AT ORIENTATION					10	10	10	10	10	
34	SETTING OF MOTOR VOLTAGE AT RIGID TAP MODE					100	100	100	100	100	
35	SETTING OF SPEED ZERO (SST) DETECTION LEVEL					75	75	75	75	75	
36	SETTING OF LOAD DETECTION LEVEL(LDT)					90	90	90	90	90	
37	TIME CONSTANT OF TORQUE DEVIATION AT DEC. START					0	0	0	0	0	
38	CHARACTERISTICS OF CONTROL IN DECELERATION					0	0	0	0	0	
39	CHAR. OF CONTROL IN STABLE ROTATION WITH NO LOAD					0	0	0	0	0	
40	CHARACTERISTICS OF CONTROL IN TORQUE LIMITATION					0	0	0	0	0	
41	CURRENT LOOP I GAIN					64	64	64	64	64	
42	SLIP COMPENSATION CONSTANT					15	15	24	10	15	
43	SLIP CONSTANT					25	40	12	30	36	
44	VOLTAGE COMPENSATION					10	10	10	10	10	
45	PWM MAXIMUM AMPLITUDE					5	5	5	5	8	
46	SECONDALY CURRENT CONSTANT					18	34	37	36	44	
47	CURRENT ESTIMATION CONSTANT					8	8	8	8	8	
48	CONSTANT TORQUE POINT					36	35	49	53	53	
49	EXCITATION WEAKENING POINT					32	32	48	45	41	
50	VOLTAGE CONVERSION CONSTANT					142	126	140	176	142	
51	GEAR = 128 : 1, 256 : 2					1	1	2	2	2	
52	CURRENT CONVERSION CONSTANT					120	88	118	122	82	
53	CURRENT LOOP P GAIN					30	20	18	11	20	

PARAMETER TABLE FOR AC SPINDLE SERVO UNIT S series (F-00 ~ 53)

(5/11)

F-	CONTENTS OF PARAMETER	MODEL		18S/ 8000	22S/ 8000	9840	9841	9842	9843	8VH/ 20000	12VH/ 15000	9846		
		SERIES · EDITION	UNIT							9838B	9839B		9844A	9845A
										H218	H222		H212	H215
00	MOTOR SPEED INDICATION													
01	USE/NO USE OF THE MACHINE READY SIGNAL(MRDY)			1	1					1	1			
02	USE/NO USE OF SPEED OVERRIDE FUNCTION			1	1					1	1			
03	OVERRIDE RANGE SETTING			1	1					1	1			
04	MOTOR SPEED INDICATION													
05	SETTING OF MAXIMUM ROTATION SPEED			2	2					3	2			
06	OUTPUT POWER LIMIT PATTERN SETTING			0	0					0	0			
07	SETTING OF LIMIT VALUE AT OUTPUT POWER LIMIT			100	100					100	100			
08	DELAY TIME BEFORE CUTTING MOTOR POWER SUPPLY			5	5					5	5			
09	USE/NO USE OF MOTOR POWER SUPPLY CUT-OFF BY MRDY			0	0					0	0			
10	VELOCITY DEVIATION OFFSET ADJUSTMENT AT SFR									Adjustment value				
11	VELOCITY DEVIATION OFFSET ADJUSTMENT AT SRV									Adjustment value				
12	VELOCITY DEVIATION OFFSET ADJUSTMENT AT ORCM									Adjustment value				
13	ROTATION SPEED ADJUSTMENT AT SFR									Adjustment value				
14	ROTATION SPEED ADJUSTMENT AT SRV									Adjustment value				
15	SETTING OF ROTATION SPEED AT VELOCITY COMMAND, 10V			80	80					200	150			
16	DETECTION RANGE OF SPEED ARRIVAL SIGNAL(SAR)			15	15					15	15			
17	DETECTION RANGE OF SPEED DETECTION SIGNAL(SDT)			3	3					3	3			
18	SETTING OF TORQUE LIMIT VALUE			50	50					50	50			
19	SETTING OF ACCELERATION/DECELERATION TIME			10	10					30	20			
20	LIMITING OF REGENERATING POWER(ADJ. OF DEC. TIME)			40	40					60	60			
21	VELOCITY LOOP P GAIN :HIGH GEAR(CTH=1)			50	50					100	75			
22	VELOCITY LOOP P GAIN :LOW GEAR(CTH=0)			50	50					100	75			
23	VELOCITY LOOP P GAIN AT ORIENTATION:HIGH GEAR			100	100					200	150			
24	VELOCITY LOOP P GAIN AT ORIENTATION:LOW GEAR			100	100					200	150			
25	VELOCITY LOOP I GAIN :HIGH GEAR(CTH=1)			30	30					60	45			
26	VELOCITY LOOP I GAIN :LOW GEAR(CTH=0)			30	30					60	45			
27	VELOCITY LOOP I GAIN AT ORIENTATION:HIGH GEAR			30	30					60	45			
28	VELOCITY LOOP I GAIN AT ORIENTATION:LOW GEAR			30	30					60	45			
29	ADJUSTMENT OF VELOCITY DETECTION OFFSET									Adjustment value				
30	MOTOR SPEED INDICATION													
31	SETTING OF RIGID TAP MODE			0	0					0	0			
32	SETTING OF MOTOR VOLTAGE AT NORMAL OPERATION			10	10					7	7			
33	SETTING OF MOTOR VOLTAGE AT ORIENTATION			10	10					10	10			
34	SETTING OF MOTOR VOLTAGE AT RIGID TAP MODE			100	100					100	100			
35	SETTING OF SPEED ZERO (SST) DETECTION LEVEL			75	75					75	75			
36	SETTING OF LOAD DETECTION LEVEL(LDT)			90	90					90	90			
37	TIME CONSTANT OF TORQUE DEVIATION AT DEC. START			0	0					0	0			
38	CHARACTERISTICS OF CONTROL IN DECELERATION			0	0					0	0			
39	CHAR. OF CONTROL IN STABLE ROTATION WITH NO LOAD			0	0					0	0			
40	CHARACTERISTICS OF CONTROL IN TORQUE LIMITATION			0	0					0	0			
41	CURRENT LOOP I GAIN			64	64					64	64			
42	SLIP COMPENSATION CONSTANT			15	15					30	25			
43	SLIP CONSTANT			32	32					18	63			
44	VOLTAGE COMPENSATION			10	10					10	10			
45	PWM MAXIMUM AMPLITUDE			8	8					5	5			
46	SECONDARY CURRENT CONSTANT			36	42					25	28			
47	CURRENT ESTIMATION CONSTANT			8	8					8	8			
48	CONSTANT TORQUE POINT			32	32					55	30			
49	EXCITATION WEAKENING POINT			32	32					64	30			
50	VOLTAGE CONVERSION CONSTANT			140	140					62	150			
51	GEAR = 128 : 1, 256 : 2			2	2					1	1			
52	CURRENT CONVERSION CONSTANT			122	122					163	111			
53	CURRENT LOOP P GAIN			12	12					6	10			

PARAMETER TABLE FOR AC SPINDLE SERVO UNIT S series (F-00 ~ 53)

(6/11)

F-	CONTENTS OF PARAMETER	MODEL			8P	12P	15P	18P	22P (1:12)	30P	
		SERIES · EDITION	9847	9848	9849	9850A	9851A	9852B	9853B	9854B	9855A
		UNIT				H206	H206	H208	H212	H215	H218
00	MOTOR SPEED INDICATION										
01	USE/NO USE OF THE MACHINE READY SIGNAL(MRDY)				1	1	1	1	1	1	
02	USE/NO USE OF SPEED OVERRIDE FUNCTION				1	1	1	1	1	1	
03	OVERRIDE RANGE SETTING				1	1	1	1	1	1	
04	MOTOR SPEED INDICATION										
05	SETTING OF MAXIMUM ROTATION SPEED				1	1	1	1	1	0	
06	OUTPUT POWER LIMIT PATTERN SETTING				0	0	0	0	0	0	
07	SETTING OF LIMIT VALUE AT OUTPUT POWER LIMIT				100	100	100	100	100	100	
08	DELAY TIME BEFORE CUTTING MOTOR POWER SUPPLY				5	5	5	5	5	5	
09	USE/NO USE OF MOTOR POWER SUPPLY CUT-OFF BY MRDY				0	0	0	0	0	0	
10	VELOCITY DEVIATION OFFSET ADJUSTMENT AT SFR				Adjustment value						
11	VELOCITY DEVIATION OFFSET ADJUSTMENT AT SRV				Adjustment value						
12	VELOCITY DEVIATION OFFSET ADJUSTMENT AT ORCM				Adjustment value						
13	ROTATION SPEED ADJUSTMENT AT SFR				Adjustment value						
14	ROTATION SPEED ADJUSTMENT AT SRV				Adjustment value						
15	SETTING OF ROTATION SPEED AT VELOCITY COMMAND, 10V				60	60	60	60	60	45	
16	DETECTION RANGE OF SPEED ARRIVAL SIGNAL(SAR)				15	15	15	15	15	15	
17	DETECTION RANGE OF SPEED DETECTION SIGNAL(SDT)				3	3	3	3	3	3	
18	SETTING OF TORQUE LIMIT VALUE				50	50	50	50	50	50	
19	SETTING OF ACCELERATION/DECELERATION TIME				10	10	10	10	10	10	
20	LIMITING OF REGENERATING POWER(ADJ. OF DEC. TIME)				60	70	50	70	50	70	
21	VELOCITY LOOP P GAIN :HIGH GEAR(CTH=1)				50	50	50	50	50	50	
22	VELOCITY LOOP P GAIN :LOW GEAR(CTH=0)				50	50	50	50	50	50	
23	VELOCITY LOOP P GAIN AT ORIENTATION:HIGH GEAR				100	100	100	100	100	100	
24	VELOCITY LOOP P GAIN AT ORIENTATION:LOW GEAR				100	100	100	100	100	100	
25	VELOCITY LOOP I GAIN :HIGH GEAR(CTH=1)				30	30	30	30	10	30	
26	VELOCITY LOOP I GAIN :LOW GEAR(CTH=0)				30	30	30	30	30	30	
27	VELOCITY LOOP I GAIN AT ORIENTATION:HIGH GEAR				30	30	30	30	30	30	
28	VELOCITY LOOP I GAIN AT ORIENTATION:LOW GEAR				30	30	30	30	30	30	
29	ADJUSTMENT OF VELOCITY DETECTION OFFSET				Adjustment value						
30	MOTOR SPEED INDICATION										
31	SETTING OF RIGID TAP MODE				0	0	0	0	0	0	
32	SETTING OF MOTOR VOLTAGE AT NORMAL OPERATION				10	10	10	10	10	10	
33	SETTING OF MOTOR VOLTAGE AT ORIENTATION				10	10	10	10	10	10	
34	SETTING OF MOTOR VOLTAGE AT RIGID TAP MODE				100	100	100	100	100	100	
35	SETTING OF SPEED ZERO (SST) DETECTION LEVEL				75	75	75	75	75	75	
36	SETTING OF LOAD DETECTION LEVEL(LDT)				90	90	90	90	90	90	
37	TIME CONSTANT OF TORQUE DEVIATION AT DEC. START				0	0	0	0	0	0	
38	CHARACTERISTICS OF CONTROL IN DECELERATION				0	0	0	0	0	0	
39	CHAR. OF CONTROL IN STABLE ROTATION WITH NO LOAD				0	0	0	0	0	0	
40	CHARACTERISTICS OF CONTROL IN TORQUE LIMITATION				0	0	0	0	0	0	
41	CURRENT LOOP I GAIN				64	64	64	64	64	64	
42	SLIP COMPENSATION CONSTANT				10	10	10	10	20	10	
43	SLIP CONSTANT				22	57	36	34	37	80	
44	VOLTAGE COMPENSATION				10	10	10	10	10	10	
45	PWM MAXIMUM AMPLITUDE				5	5	5	5	10	8	
46	SECONDARY CURRENT CONSTANT				48	62	34	27	50	49	
47	CURRENT ESTIMATION CONSTANT				8	8	8	8	8	8	
48	CONSTANT TORQUE POINT				34	25	22	47	16	45	
49	EXCITATION WEAKENING POINT				43	42	37	41	44	34	
50	VOLTAGE CONVERSION CONSTANT				95	115	124	109	120	138	
51	GEAR = 128 : 1 .256 : 2				2	2	2	2	2	2	
52	CURRENT CONVERSION CONSTANT				70	86	150	169	110	88	
53	CURRENT LOOP P GAIN				12	20	20	10	20	20	

PARAMETER TABLE FOR AC SPINDLE SERVO UNIT S series (F-00 ~ 53)

(7/11)

F-	CONTENTS OF PARAMETER	MODEL	40P (1:12)				B6S 15kW	6S	15P (1:12)	18P (1:12)	6S 12000
		SERIES • EDITION	9856A	9857	9858	9859	9860A	9861C	9862A	9863C	9864B
		UNIT	H222				H222	H206	H208	H212	H208
00	MOTOR SPEED INDICATION										
01	USE/NO USE OF THE MACHINE READY SIGNAL(MRDY)		1				1	1	1	1	1
02	USE/NO USE OF SPEED OVERRIDE FUNCTION		1				1	1	1	1	1
03	OVERRIDE RANGE SETTING		1				1	1	1	1	1
04	MOTOR SPEED INDICATION										
05	SETTING OF MAXIMUM ROTATION SPEED		1				1	1	1	1	1
06	OUTPUT POWER LIMIT PATTERN SETTING		5				0	0	5	5	0
07	SETTING OF LIMIT VALUE AT OUTPUT POWER LIMIT		93				100	100	86	86	100
08	DELAY TIME BEFORE CUTTING MOTOR POWER SUPPLY		5				5	5	5	5	5
09	USE/NO USE OF MOTOR POWER SUPPLY CUT-OFF BY MRDY		0				0	0	0	0	0
10	VELOCITY DEVIATION OFFSET ADJUSTMENT AT SFR						Adjustment value				
11	VELOCITY DEVIATION OFFSET ADJUSTMENT AT SRV						Adjustment value				
12	VELOCITY DEVIATION OFFSET ADJUSTMENT AT ORCM						Adjustment value				
13	ROTATION SPEED ADJUSTMENT AT SFR						Adjustment value				
14	ROTATION SPEED ADJUSTMENT AT SRV						Adjustment value				
15	SETTING OF ROTATION SPEED AT VELOCITY COMMAND, 10V		48				60	60	60	60	120
16	DETECTION RANGE OF SPEED ARRIVAL SIGNAL(SAR)		15				15	15	15	15	15
17	DETECTION RANGE OF SPEED DETECTION SIGNAL(SDT)		3				3	3	3	3	3
18	SETTING OF TORQUE LIMIT VALUE		50				50	50	50	50	50
19	SETTING OF ACCELERATION/DECELERATION TIME		10				10	20	10	10	10
20	LIMITING OF REGENERATING POWER(ADJ. OF DEC. TIME)		60				40	60	70	70	40
21	VELOCITY LOOP P GAIN :HIGH GEAR(CTH=1)		50				100	40	50	100	100
22	VELOCITY LOOP P GAIN :LOW GEAR(CTH=0)		50				100	40	50	50	100
23	VELOCITY LOOP P GAIN AT ORIENTATION:HIGH GEAR		100				100	80	100	100	200
24	VELOCITY LOOP P GAIN AT ORIENTATION:LOW GEAR		100				100	80	100	100	200
25	VELOCITY LOOP I GAIN :HIGH GEAR(CTH=1)		30				60	40	10	10	60
26	VELOCITY LOOP I GAIN :LOW GEAR(CTH=0)		30				60	40	30	30	60
27	VELOCITY LOOP I GAIN AT ORIENTATION:HIGH GEAR		30				30	40	30	30	60
28	VELOCITY LOOP I GAIN AT ORIENTATION:LOW GEAR		30				30	40	30	30	60
29	ADJUSTMENT OF VELOCITY DETECTION OFFSET						Adjustment value				
30	MOTOR SPEED INDICATION										
31	SETTING OF RIGID TAP MODE		0				0	0	0	0	0
32	SETTING OF MOTOR VOLTAGE AT NORMAL OPERATION		10				7	10	7	40	7
33	SETTING OF MOTOR VOLTAGE AT ORIENTATION		10				10	10	10	10	10
34	SETTING OF MOTOR VOLTAGE AT RIGID TAP MODE		100				100	100	100	100	100
35	SETTING OF SPEED ZERO (SST) DETECTION LEVEL		75				75	75	75	75	75
36	SETTING OF LOAD DETECTION LEVEL(LDT)		90				90	90	90	90	90
37	TIME CONSTANT OF TORQUE DEVIATION AT DEC. START		0				0	0	0	0	0
38	CHARACTERISTICS OF CONTROL IN DECELERATION		0				0	0	0	0	0
39	CHAR. OF CONTROL IN STABLE ROTATION WITH NO LOAD		0				0	0	0	0	0
40	CHARACTERISTICS OF CONTROL IN TORQUE LIMITATION		0				0	0	0	0	0
41	CURRENT LOOP I GAIN		64				64	64	64	64	64
42	SLIP COMPENSATION CONSTANT		10				15	15	10	10	5
43	SLIP CONSTANT		39				45	26	41	41	40
44	VOLTAGE COMPENSATION		20				10	10	10	10	10
45	PWM MAXIMUM AMPLITUDE		8				8	5	5	5	5
46	SECONDALY CURRENT CONSTANT		27				60	17	42	39	44
47	CURRENT ESTIMATION CONSTANT		8				8	8	8	8	8
48	CONSTANT TORQUE POINT		22				43	72	21	42	35
49	EXCITATION WEAKENING POINT		24				48	64	36	50	32
50	VOLTAGE CONVERSION CONSTANT		147				82	71	142	68	126
51	GEAR = 128 : 1 . 256 : 2		2				2	1	2	2	1
52	CURRENT CONVERSION CONSTANT		185				82	120	112	155	88
53	CURRENT LOOP P GAIN		20				15	30	20	12	20

PARAMETER TABLE FOR AC SPINDLE SERVO UNIT S series (F-00 ~ 53)

(8/11)

F-	CONTENTS OF PARAMETER	MODEL	15P (1:12)	6S/A3 8000	6S/9kW	B8		18P/ 8000	2S	1S	15S Oil cool
		SERIES • EDITION	9865A	9866A	9867C	9868A	9869	9870A	9871B	9872A	9873B
		UNIT	H208	H203	H206	H212		H212	H203	H203	H218
00	MOTOR SPEED INDICATION										
01	USE/NO USE OF THE MACHINE READY SIGNAL(MRDY)		1	1	1	1		1	1	1	1
02	USE/NO USE OF SPEED OVERRIDE FUNCTION		1	1	1	1		1	1	1	1
03	OVERRIDE RANGE SETTING		1	1	1	1		1	1	1	1
04	MOTOR SPEED INDICATION										
05	SETTING OF MAXIMUM ROTATION SPEED		1	2	1	3		2	0	0	1
06	OUTPUT POWER LIMIT PATTERN SETTING		5	0	0	0		0	0	0	0
07	SETTING OF LIMIT VALUE AT OUTPUT POWER LIMIT		67	100	100	100		100	100	100	100
08	DELAY TIME BEFORE CUTTING MOTOR POWER SUPPLY		5	5	5	5		5	5	5	5
09	USE/NO USE OF MOTOR POWER SUPPLY CUT-OFF BY MRDY		0	0	0	0		0	0	0	0
10	VELOCITY DEVIATION OFFSET ADJUSTMENT AT SFR		Adjustment value								
11	VELOCITY DEVIATION OFFSET ADJUSTMENT AT SRV		Adjustment value								
12	VELOCITY DEVIATION OFFSET ADJUSTMENT AT ORCM		Adjustment value								
13	ROTATION SPEED ADJUSTMENT AT SFR		Adjustment value								
14	ROTATION SPEED ADJUSTMENT AT SRV		Adjustment value								
15	SETTING OF ROTATION SPEED AT VELOCITY COMMAND. 10V		60	80	60	130		80	80	80	100
16	DETECTION RANGE OF SPEED ARRIVAL SIGNAL(SAR)		15	15	15	15		15	15	15	15
17	DETECTION RANGE OF SPEED DETECTION SIGNAL(SDT)		3	3	3	3		3	3	3	3
18	SETTING OF TORQUE LIMIT VALUE		50	50	50	50		50	50	50	50
19	SETTING OF ACCELERATION/DECELERATION TIME		10	10	10	20		10	10	10	20
20	LIMITING OF REGENERATING POWER(ADJ. OF DEC. TIME)		40	40	40	40		55	60	40	60
21	VELOCITY LOOP P GAIN :HIGH GEAR(CTH=1)		50	50	50	50		50	50	50	50
22	VELOCITY LOOP P GAIN :LOW GEAR(CTH=0)		50	50	50	50		50	50	50	50
23	VELOCITY LOOP P GAIN AT ORIENTATION:HIGH GEAR		100	100	100	100		100	100	100	100
24	VELOCITY LOOP P GAIN AT ORIENTATION:LOW GEAR		100	100	100	100		100	100	100	100
25	VELOCITY LOOP I GAIN :HIGH GEAR(CTH=1)		10	30	30	30		30	20	30	30
26	VELOCITY LOOP I GAIN :LOW GEAR(CTH=0)		30	30	30	30		30	20	30	30
27	VELOCITY LOOP I GAIN AT ORIENTATION:HIGH GEAR		30	30	30	30		30	30	30	30
28	VELOCITY LOOP I GAIN AT ORIENTATION:LOW GEAR		30	30	30	30		30	30	30	30
29	ADJUSTMENT OF VELOCITY DETECTION OFFSET		Adjustment value								
30	MOTOR SPEED INDICATION										
31	SETTING OF RIGID TAP MODE		0	0	0	0		0	0	0	0
32	SETTING OF MOTOR VOLTAGE AT NORMAL OPERATION		10	10	10	10		10	7	10	7
33	SETTING OF MOTOR VOLTAGE AT ORIENTATION		10	10	10	10		10	10	10	10
34	SETTING OF MOTOR VOLTAGE AT RIGID TAP MODE		100	100	100	100		100	100	100	100
35	SETTING OF SPEED ZERO (SST) DETECTION LEVEL		75	75	75	75		75	75	75	75
36	SETTING OF LOAD DETECTION LEVEL(LDT)		90	90	90	90		90	90	90	90
37	TIME CONSTANT OF TORQUE DEVIATION AT DEC. START		0	0	0	0		0	0	0	0
38	CHARACTERISTICS OF CONTROL IN DECELERATION		0	0	0	0		0	0	0	0
39	CHAR. OF CONTROL IN STABLE ROTATION WITH NO LOAD		0	0	0	0		0	0	0	0
40	CHARACTERISTICS OF CONTROL IN TORQUE LIMITATION		0	0	0	0		0	0	0	0
41	CURRENT LOOP I GAIN		64	64	64	64		64	64	64	64
42	SLIP COMPENSATION CONSTANT		10	20	30	10		10	10	25	10
43	SLIP CONSTANT		36	16	31	17		41	22	12	53
44	VOLTAGE COMPENSATION		10	10	10	10		10	10	10	10
45	PWM MAXIMUM AMPLITUDE		5	5	5	5		5	5	5	5
46	SECONDARY CURRENT CONSTANT		31	26	60	35		39	24	20	26
47	CURRENT ESTIMATION CONSTANT		8	8	8	8		8	8	8	8
48	CONSTANT TORQUE POINT		23	36	77	32		18	40	58	64
49	EXCITATION WEAKENING POINT		37	32	64	24		25	46	61	55
50	VOLTAGE CONVERSION CONSTANT		124	126	63	230		136	100	72	90
51	GEAR = 128 : 1,256 : 2		2	2	2	2		2	1	1	1
52	CURRENT CONVERSION CONSTANT		150	88	88	135		155	77	45	111
53	CURRENT LOOP P GAIN		20	20	20	20		12	20	20	13

PARAMETER TABLE FOR AC SPINDLE SERVO UNIT S series (F-00 ~ 53)

(9/11)

F-	CONTENTS OF PARAMETER	MODEL	8VH Special	B6	B6 P-Up	40P	2S/256	40P (1:8)	B12	B12	22P (1:8)
		SERIES - EDITION	9874B	9875A	9876A	9877A	9878A	9879A	9880A	9881A	9882A
		UNIT	H212	H206	H208	H222	H002	H222	H206	H208	H215
00	MOTOR SPEED INDICATION										
01	USE/NO USE OF THE MACHINE READY SIGNAL(MRDY)		1	1	1	1	1	1	1	1	1
02	USE/NO USE OF SPEED OVERRIDE FUNCTION		1	1	1	1		1	1	1	1
03	OVERRIDE RANGE SETTING		1	1	1	1		1	1	1	1
04	MOTOR SPEED INDICATION										
05	SETTING OF MAXIMUM ROTATION SPEED		1	3	3	1		0	1	1	1
06	OUTPUT POWER LIMIT PATTERN SETTING		0	0	0	5	0	0	0	0	5
07	SETTING OF LIMIT VALUE AT OUTPUT POWER LIMIT		100	100	100	88	100	100	100	100	88
08	DELAY TIME BEFORE CUTTING MOTOR POWER SUPPLY		5	5	5	5	5	5	5	5	5
09	USE/NO USE OF MOTOR POWER SUPPLY CUT-OFF BY MRDY		0	0	0	0	0	0	0	0	0
10	VELOCITY DEVIATION OFFSET ADJUSTMENT AT SFR		Adjustment value								
11	VELOCITY DEVIATION OFFSET ADJUSTMENT AT SRV		Adjustment value								
12	VELOCITY DEVIATION OFFSET ADJUSTMENT AT ORCM		Adjustment value								
13	ROTATION SPEED ADJUSTMENT AT SFR		Adjustment value								
14	ROTATION SPEED ADJUSTMENT AT SRV		Adjustment value								
15	SETTING OF ROTATION SPEED AT VELOCITY COMMAND, 10V		120	100	100	60	80	45	60	60	60
16	DETECTION RANGE OF SPEED ARRIVAL SIGNAL(SAR)		15	15	15	15	15	15	15	15	15
17	DETECTION RANGE OF SPEED DETECTION SIGNAL(SDT)		3	3	3	3	3	3	3	3	3
18	SETTING OF TORQUE LIMIT VALUE		50	50	50	50	50	50	50	50	50
19	SETTING OF ACCELERATION/DECELERATION TIME		20	10	10	10	10	10	10	10	10
20	LIMITING OF REGENERATING POWER(ADJ. OF DEC. TIME)		60	40	40	40	60	40	70	70	40
21	VELOCITY LOOP P GAIN :HIGH GEAR(CTH=1)		60	50	50	50	15	50	50	50	50
22	VELOCITY LOOP P GAIN :LOW GEAR(CTH=0)		60	50	50	50	20	50	50	50	50
23	VELOCITY LOOP P GAIN AT ORIENTATION:HIGH GEAR		120	100	100	100	40	100	100	100	100
24	VELOCITY LOOP P GAIN AT ORIENTATION:LOW GEAR		120	100	100	100	40	100	100	100	100
25	VELOCITY LOOP I GAIN :HIGH GEAR(CTH=1)		36	30	30	30	10	30	30	30	30
26	VELOCITY LOOP I GAIN :LOW GEAR(CTH=0)		36	30	30	30	10	30	30	30	30
27	VELOCITY LOOP I GAIN AT ORIENTATION:HIGH GEAR		36	30	30	30	10	30	30	30	30
28	VELOCITY LOOP I GAIN AT ORIENTATION:LOW GEAR		36	30	30	30	10	30	30	30	30
29	ADJUSTMENT OF VELOCITY DETECTION OFFSET		Adjustment value								
30	MOTOR SPEED INDICATION										
31	SETTING OF RIGID TAP MODE		0	0	0	0	0	0	0	0	0
32	SETTING OF MOTOR VOLTAGE AT NORMAL OPERATION		7	10	10	10	10	10	10	10	10
33	SETTING OF MOTOR VOLTAGE AT ORIENTATION		10	10	10	10	10	10	10	10	10
34	SETTING OF MOTOR VOLTAGE AT RIGID TAP MODE		100	100	100	100	100	100	100	100	100
35	SETTING OF SPEED ZERO (SST) DETECTION LEVEL		75	75	75	75	75	75	75	75	75
36	SETTING OF LOAD DETECTION LEVEL(LDT)		90	90	90	90	90	90	90	90	90
37	TIME CONSTANT OF TORQUE DEVIATION AT DEC. START		0	0	0	0	0	0	0	0	0
38	CHARACTERISTICS OF CONTROL IN DECELERATION		0	0	0	0	0	0	0	0	0
39	CHAR. OF CONTROL IN STABLE ROTATION WITH NO LOAD		0	0	0	0	0	0	0	0	0
40	CHARACTERISTICS OF CONTROL IN TORQUE LIMITATION		0	0	0	0	0	0	0	0	0
41	CURRENT LOOP I GAIN		64	64	64	64	64	64	64	64	64
42	SLIP COMPENSATION CONSTANT		15	10	8	10	20	10	10	10	10
43	SLIP CONSTANT		20	15	12	39	12	31	38	38	44
44	VOLTAGE COMPENSATION		10	10	10	20	10	20	10	10	10
45	PWM MAXIMUM AMPLITUDE		5	5	5	8	5	8	5	5	8
46	SECONDALY CURRENT CONSTANT		15	32	37	27	25	24	39	52	44
47	CURRENT ESTIMATION CONSTANT		8	8	8	8	8	8	8	8	8
48	CONSTANT TORQUE POINT		58	23	45	24	48	24	32	32	42
49	EXICITATION WEAKENING POINT		53	39	42	26	44	26	43	43	42
50	VOLTAGE CONVERSION CONSTANT		100	134	116	147	100	147	102	102	100
51	GEAR = 128 : 1, 256 : 2		1	2	2	2	2	2	2	2	2
52	CURRENT CONVERSION CONSTANT		140	92	114	185	115	185	74	74	90
53	CURRENT LOOP P GAIN		9	20	20	20	20	20	20	20	20

F-	CONTENTS OF PARAMETER	MODEL	6S	B6		15P	8VH	B1H	8S	18P	12S
			8000						F-54	8000	8000
		SERIES · EDITION	9883A	9884A	9885	9886A	9887A	9888B	9889A	9890A	9891A
	UNIT	H208	H208		H208	H215	H001	H208	H212	H212	
00	MOTOR SPEED INDICATION										
01	USE/NO USE OF THE MACHINE READY SIGNAL(MRDY)	1	1		1	1	1	1	1	1	1
02	USE/NO USE OF SPEED OVERRIDE FUNCTION	1	1		1	1		1	1	1	
03	OVERRIDE RANGE SETTING	1	1		1	1		1	1	1	
04	MOTOR SPEED INDICATION										
05	SETTING OF MAXIMUM ROTATION SPEED	2	3		2	3		0	2	2	
06	OUTPUT POWER LIMIT PATTERN SETTING	0	0		5	0	0	0	0	0	
07	SETTING OF LIMIT VALUE AT OUTPUT POWER LIMIT	100	100		60	100	100	100	100	100	
08	DELAY TIME BEFORE CUTTING MOTOR POWER SUPPLY	5	5		5	5	5	5	5	5	
09	USE/NO USE OF MOTOR POWER SUPPLY CUT-OFF BY MRDY	0	0		0	0	0	0	0	0	
10	VELOCITY DEVIATION OFFSET ADJUSTMENT AT SFR	Adjustment value									
11	VELOCITY DEVIATION OFFSET ADJUSTMENT AT SRV	Adjustment value									
12	VELOCITY DEVIATION OFFSET ADJUSTMENT AT DRGM	Adjustment value									
13	ROTATION SPEED ADJUSTMENT AT SFR	Adjustment value									
14	ROTATION SPEED ADJUSTMENT AT SRV	Adjustment value									
15	SETTING OF ROTATION SPEED AT VELOCITY COMMAND, 10V	80	120		80	200	200	45	80	80	
16	DETECTION RANGE OF SPEED ARRIVAL SIGNAL(SAR)	15	15		15	15	15	15	15	15	
17	DETECTION RANGE OF SPEED DETECTION SIGNAL(SDT)	3	3		3	3	3	3	3	3	
18	SETTING OF TORQUE LIMIT VALUE	50	50		50	50	50	50	50	50	
19	SETTING OF ACCELERATION/DECELERATION TIME	20	10		10	30	20	10	10	10	
20	LIMITING OF REGENERATING POWER(ADJ. OF DEC. TIME)	60	40		40	80	60	40	55	40	
21	VELOCITY LOOP P GAIN :HIGH GEAR(CTH=1)	67	50		50	100	20	20	50	50	
22	VELOCITY LOOP P GAIN :LOW GEAR(CTH=0)	67	50		50	100	20	20	50	50	
23	VELOCITY LOOP P GAIN AT ORIENTATION:HIGH GEAR	80	100		100	200	40	100	100	100	
24	VELOCITY LOOP P GAIN AT ORIENTATION:LOW GEAR	80	100		100	200	40	100	100	100	
25	VELOCITY LOOP I GAIN :HIGH GEAR(CTH=1)	100	30		40	60	10	30	30	40	
26	VELOCITY LOOP I GAIN :LOW GEAR(CTH=0)	100	30		40	60	10	30	30	40	
27	VELOCITY LOOP I GAIN AT ORIENTATION:HIGH GEAR	40	30		40	60	10	30	30	40	
28	VELOCITY LOOP I GAIN AT ORIENTATION:LOW GEAR	40	30		40	60	10	30	30	40	
29	ADJUSTMENT OF VELOCITY DETECTION OFFSET	Adjustment value									
30	MOTOR SPEED INDICATION										
31	SETTING OF RIGID TAP MODE	0	0		0	0	0	0	0	0	
32	SETTING OF MOTOR VOLTAGE AT NORMAL OPERATION	10	10		5	10	10	10	10	10	
33	SETTING OF MOTOR VOLTAGE AT ORIENTATION	10	10		10	10	10	10	10	10	
34	SETTING OF MOTOR VOLTAGE AT RIGID TAP MODE	100	100		100	100	100	100	100	100	
35	SETTING OF SPEED ZERO (SST) DETECTION LEVEL	75	75		75	75	75	75	75	75	
36	SETTING OF LOAD DETECTION LEVEL(LDT)	90	90		90	90	90	90	90	90	
37	TIME CONSTANT OF TORQUE DEVIATION AT DEC. START	0	0		0	0	0	0	0	0	
38	CHARACTERISTICS OF CONTROL IN DECELERATION	0	0		0	0	0	0	0	0	
39	CHAR. OF CONTROL IN STABLE ROTATION WITH NO LOAD	0	0		0	0	0	0	0	0	
40	CHARACTERISTICS OF CONTROL IN TORQUE LIMITATION	0	0		0	0	0	0	0	0	
41	CURRENT LOOP I GAIN	64	64		64	64	64	64	64	64	
42	SLIP COMPENSATION CONSTANT	15	15		10	35	10	10	10	10	
43	SLIP CONSTANT	12	14		40	31	11	16	41	30	
44	VOLTAGE COMPENSATION	10	10		10	10	10	10	10	10	
45	PWM MAXIMUM AMPLITUDE	5	5		5	5	5	5	5	5	
46	SECONDALY CURRENT CONSTANT	25	34		52	33	21	30	34	36	
47	CURRENT ESTIMATION CONSTANT	8	8		8	8	8	8	8	8	
48	CONSTANT TORQUE POINT	36	36		25	76	64	71	20	53	
49	EXICITATION WEAKENING POINT	32	35		25	64	64	56	24	45	
50	VOLTAGE CONVERSION CONSTANT	164	130		230	75	69	73	212	176	
51	GEAR = 128 : 1.256 : 2	2	2		2	1	1	2	2	2	
52	CURRENT CONVERSION CONSTANT	130	93		103	120	68	127	148	122	
53	CURRENT LOOP P GAIN	30	20		20	8	30	18	12	11	

F54=50

F-	CONTENTS OF PARAMETER	MODEL		50P/60P										
		SERIES · EDITION		9B05										
		UNIT	SUB	MAIN										
00	MOTOR SPEED INDICATION													
01	USE/NO USE OF THE MACHINE READY SIGNAL(MRDY)		1											
02	USE/NO USE OF SPEED OVERRIDE FUNCTION		1											
03	OVERRIDE RANGE SETTING		1											
04	MOTOR SPEED INDICATION													
05	SETTING OF MAXIMUM ROTATION SPEED		0	0										
06	OUTPUT POWER LIMIT PATTERN SETTING		2	2										
07	SETTING OF LIMIT VALUE AT OUTPUT POWER LIMIT		100	84										
08	DELAY TIME BEFORE CUTTING MOTOR POWER SUPPLY		5											
09	USE/NO USE OF MOTOR POWER SUPPLY CUT-OFF BY MRDY		0											
10	VELOCITY DEVIATION OFFSET ADJUSTMENT AT SFR		Adjustment value											
11	VELOCITY DEVIATION OFFSET ADJUSTMENT AT SRV		Adjustment value											
12	VELOCITY DEVIATION OFFSET ADJUSTMENT AT ORCM		Adjustment value											
13	ROTATION SPEED ADJUSTMENT AT SFR		Adjustment value											
14	ROTATION SPEED ADJUSTMENT AT SRV		Adjustment value											
15	SETTING OF ROTATION SPEED AT VELOCITY COMMAND, 10V		45	45										
16	DETECTION RANGE OF SPEED ARRIVAL SIGNAL(SAR)		15	15										
17	DETECTION RANGE OF SPEED DETECTION SIGNAL(SDT)		15	15										
18	SETTING OF TORQUE LIMIT VALUE		50	50										
19	SETTING OF ACCELERATION/DECELERATION TIME		10	10										
20	LIMITING OF REGENERATING POWER(ADJ. OF DEC. TIME)		60	60										
21	VELOCITY LOOP P GAIN :HIGH GEAR(CTH=1)		50	50										
22	VELOCITY LOOP P GAIN :LOW GEAR(CTH=0)													
23	VELOCITY LOOP P GAIN AT ORIENTATION:HIGH GEAR		100	100										
24	VELOCITY LOOP P GAIN AT ORIENTATION:LOW GEAR													
25	VELOCITY LOOP I GAIN :HIGH GEAR(CTH=1)		30	30										
26	VELOCITY LOOP I GAIN :LOW GEAR(CTH=0)			30										
27	VELOCITY LOOP I GAIN AT ORIENTATION:HIGH GEAR		30	30										
28	VELOCITY LOOP I GAIN AT ORIENTATION:LOW GEAR													
29	ADJUSTMENT OF VELOCITY DETECTION OFFSET		Adjustment value											
30	MOTOR SPEED INDICATION													
31	SETTING OF RIGID TAP MODE		0	0										
32	SETTING OF MOTOR VOLTAGE AT NORMAL OPERATION		10	10										
33	SETTING OF MOTOR VOLTAGE AT ORIENTATION		10	10										
34	SETTING OF MOTOR VOLTAGE AT RIGID TAP MODE		100	100										
35	SETTING OF SPEED ZERO (SST) DETECTION LEVEL		75	75										
36	SETTING OF LOAD DETECTION LEVEL(LDT)		90	90										
37	TIME CONSTANT OF TORQUE DEVIATION AT DEC. START		0	0										
38	CHARACTERISTICS OF CONTROL IN DECELERATION		0	0										
39	CHAR. OF CONTROL IN STABLE ROTATION WITH NO LOAD		0	0										
40	CHARACTERISTICS OF CONTROL IN TORQUE LIMITATION		0	0										
41	CURRENT LOOP I GAIN		64	64										
42	SLIP COMPENSATION CONSTANT		10	10										
43	SLIP CONSTANT		80	96										
44	VOLTAGE COMPENSATION		10	10										
45	PWM MAXIMUM AMPLITUDE		5	8										
46	SECONDALY CURRENT CONSTANT		80	25										
47	CURRENT ESTIMATION CONSTANT		8	8										
48	CONSTANT TORQUE POINT		24	34										
49	EXICITATION WEAKENING POINT		19	20										
50	VOLTAGE CONVERSION CONSTANT		126	115										
51	GEAR = 128 : 1, 256 : 2			2										
52	CURRENT CONVERSION CONSTANT		72	130										
53	CURRENT LOOP P GAIN		20	20										

Revision Record

AC SPINDLE SERVO UNIT S series MAINTENANCE MANUAL (B-65015E)

03	'91, 05	· Items and contents of Signal Conversion Circuit are changed.			
02	'90, 07	· Model 26S has been added. · P series has been added.			
01	'87, 11	_____			
Edition	Date	Contents	Edition	Date	Contents

- *No part of this manual may be reproduced in any form.*
- *All specifications and designs are subject to change without notice.*



0163-000213

May, 1991

FANUC LTD

Printed in Japan