

IL ETH BK DI8 DO4 2TX-PAC

**Inline, bus coupler, Modbus/TCP (UDP),
digital inputs: 8, 24 V DC,
digital outputs: 4, 24 V DC, 500 mA**



Data sheet
7275_en_10

© Phoenix Contact 2023-03-09

1 Description

The bus coupler with integrated I/Os is intended for use within a Modbus/TCP (UDP) network and represents the link to the Inline I/O system.

Up to 61 Inline devices can be connected to the bus coupler. The bus coupler supports a maximum of 16 PCP devices.

Features

- 2 Ethernet ports (with integrated switch)
- Auto negotiation
- Autocrossing
- Transmission speed of 10 Mbps and 100 Mbps
- Automatic detection of the transmission speed in the local bus (500 kbps or 2 Mbps)
- 8 digital inputs, 4 digital outputs (on-board)
- Data exchange via OPC server supported
- Software interfaces for access via TCP/IP: Device Driver Interface (DDI) and High-Level Language Fieldbus Interface (HFI)
- Web-based management



This data sheet is only valid in association with the IL SYS INST UM E user manual.



Make sure you always use the latest documentation.
It can be downloaded at: phoenixcontact.net/product/2703981

2	Table of contents	
1	Description	1
2	Table of contents	2
3	Ordering data	3
4	Technical data	5
5	Internal circuit diagram	11
6	Security in the network	12
7	Connecting Ethernet, the supply, actuators, and sensors.....	12
8	Connection example.....	13
9	Local diagnostic and status indicators	14
10	Reset button	16
11	Startup.....	17
12	Startup behavior of the bus coupler	17
13	Monitoring.....	20
14	Modbus protocols and registers	22
15	DDI: Device Driver Interface	33
16	HFI: High-Level Language Fieldbus Interface.....	37
17	SNMP: Simple Network Management Protocol	37
18	WBM: Web-based management	38
19	Firmware update.....	38
20	Process data access via XML.....	38

3 Ordering data

Description	Type	Item no.	Pcs./Pkt.
Inline, Bus coupler, Modbus/TCP(UDP), RJ45 jack, Digital inputs: 8, 24 V DC, connection technology: 3-conductor, Digital outputs: 4, 24 V DC, 500 mA, connection technology: 3-conductor, transmission speed in the local bus: 500 kbps / 2 Mbps, degree of protection: IP20, including Inline connectors and marking fields	IL ETH BK DI8 DO4 2TX-PAC	2703981	1
Accessories	Type	Item no.	Pcs./Pkt.
Quick mounting end clamp for NS 35/7,5 DIN rail or NS 35/15 DIN rail, with marking option, width: 9.5 mm, color: gray (Mounting)	CLIPFIX 35	3022218	50
End clamp, material: PA, color: gray, Mounting on a DIN rail NS 32 or NS 35 (Mounting)	E/UK	1201442	50
Insert strip, Sheet, white, unlabeled, can be labeled with: Office printing systems: Laser printer, mounting type: insert, lettering field size: 62 x 46 mm, Number of individual labels: 15 (Marking)	ESL 62X46	0809502	5
Labeling field, width: 48.8 mm (Marking)	IB IL FIELD 8	2727515	10
Insert strip, Sheet, white, unlabeled, can be labeled with: Office printing systems: Laser printer, mounting type: insert, lettering field size: 62 x 10 mm, Number of individual labels: 72 (Marking)	ESL 62X10	0809492	1
Labeling field, width: 12.2 mm (Marking)	IB IL FIELD 2	2727501	10
RJ45 connector, design: RJ45, degree of protection: IP20, number of positions: 8, 1 Gbps, CAT5 (IEC 11801:2002), material: Plastic, connection method: Crimp connection, cable outlet: straight, color: green, Ethernet (Connector/Adapter)	FL PLUG RJ45 GR/2	2744856	1
RJ45 connector, design: RJ45, degree of protection: IP20, number of positions: 8, 1 Gbps, CAT5 (IEC 11801:2002), material: Plastic, connection method: Crimp connection, cable outlet: straight, color: green, Ethernet (Connector/Adapter)	FL PLUG RJ45 GN/2	2744571	1
CAT5-SF/UTP cable (J-02YS(ST)C HP 2 x 2 x 24 AWG), heavy-duty installation cable, 2 x 2 x 0.22 mm ² , solid conductor, shielded, outer sheath: 7.8 mm diameter, inner sheath: 5.75 mm ± 0.15 mm diameter (Cable/conductor)	FL CAT5 HEAVY	2744814	1
By the meter, Installation cable, Ethernet CAT5 (100 Mbps), shielded, PUR halogen-free, water blue RAL 5021, 4-wire (2x2xAWG26/7; SF/UTP), color single wire: white/orange-orange, white/green-green, cable length: Free entry (1.0 ... 1000.0 m) (Cable/conductor)	FL CAT5 FLEX	2744830	1

Accessories	Type	Item no.	Pcs./Pkt.
Crimping pliers, for assembling the RJ45 plugs FL PLUG RJ45..., for assembly on site (Tools)	FL CRIMPTOOL	2744869	1
Connector set, for Inline bus coupler with I/Os mounted in rows (Connector/Adapter)	IL BKDIO-PLSET	2878599	1
IPAssign is an easy to use tool for setting the IP address of devices which rely on BOOTP. No installation or administrative rights are required to use IPAssign.	IPASSIGN	2701094	1

This product is free and only available from the "Downloads" tab.

Documentation	Type	Item no.	Pcs./Pkt.
User manual, English, Automation terminals of the Inline product range	IL SYS INST UM E	-	-
Application note, English, Inline terminals for use in zone 2 potentially explosive areas	AH EN IL EX ZONE 2	-	-
Application note, German/English, I/O modules at bus couplers	AH IL BK IO LIST	-	-
User manual, English, for drivers for G4-based controller boards, only available as a download.	IBS PC SC SWD UM E	2745172	1
User manual, English, for firmware messages of Generation 4 controller boards, only available as a download.	IBS SYS FW G4 UM E	2745185	1
User manual, English, for the Peripherals Communication Protocol (PCP), only available as a download.	IBS SYS PCP G4 UM E	2745169	1
Quick start guide, English, high-level language programming with HFI user interface	UM QS EN HFI PROG	-	-
Application note, English, Measures to protect network-capable devices with Ethernet connection against unauthorized access	AH EN INDUSTRIAL SECURITY	-	-

Additional ordering data

For more ordering data (accessories), visit www.phoenixcontact.net and look at the product catalogs.
 Media converters for conversion and transmission of data via fiber-optic cables (see "Automation" catalog)
 Power supplies for the bus coupler (see the "Power supplies, surge protection and device circuit breakers" catalog)

4 Technical data

Dimensions (nominal sizes in mm)

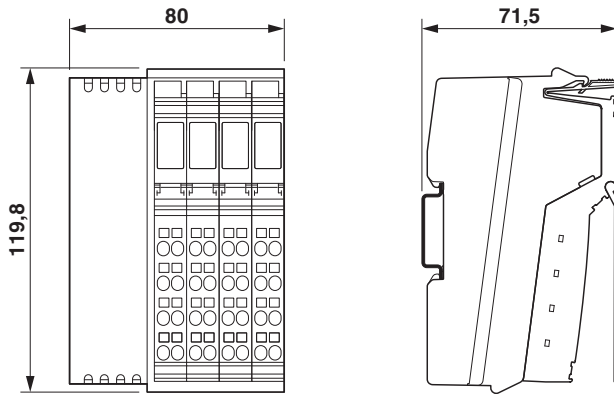

Width	80 mm
Height	119.8 mm
Depth	71.5 mm
Note on dimensions	Specifications with connectors

General data

Color	green
Weight	375 g (with connectors)
Ambient temperature (operation)	-25 °C ... 55 °C
Ambient temperature (storage/transport)	-40 °C ... 85 °C
Permissible humidity (operation)	10 % ... 95 % (non-condensing)
Permissible humidity (storage/transport)	10 % ... 95 % (non-condensing)
Air pressure (operation)	70 kPa ... 106 kPa (up to 3000 m above sea level)
Air pressure (storage/transport)	70 kPa ... 106 kPa (up to 3000 m above sea level)
Degree of protection	IP20
Protection class	III (IEC 61140, EN 61140, VDE 0140-1)
Overvoltage category	II (IEC 60664-1, EN 60664-1)
Degree of pollution	2 (IEC 60664-1, EN 60664-1)
Mounting type	DIN rail mounting

Connection data: Inline connector

Connection method	Spring-cage connection
Conductor cross section, rigid	0.08 mm ² ... 1.5 mm ²
Conductor cross section, flexible	0.08 mm ² ... 1.5 mm ²
Conductor cross section [AWG]	28 ... 16
Stripping length	8 mm

Connection data for UL approvals: Inline connector

Connection method	Spring-cage connection
Conductor cross section, rigid	0.2 mm ² ... 1.5 mm ²
Conductor cross section, flexible	0.2 mm ² ... 1.5 mm ²
Conductor cross section [AWG]	24 ... 16
Stripping length	8 mm

Interface: Modbus/TCP (UDP)

Number of interfaces	2
Connection method	RJ45 jack (Auto negotiation and autocrossing)
Transmission speed	10/100 Mbps
Transmission physics	Ethernet in RJ45 twisted pair
Transmission length	max. 100 m

Interface: Inline local bus

Connection method	Inline data jumper
Transmission speed	500 kbps / 2 Mbps (automatic detection, no combined system)

System limits of the bus coupler



Use the Project+ configuration software to calculate the individual process or parameter data and the corresponding number of devices that can be connected.

For the Project+ configuration software, go to: www.phoenixcontact.net/product/2703981

Number of local bus devices that can be connected	max. 61 (The on-board I/Os are two devices)
Number of devices with parameter channel	max. 16



Observe the logic current consumption of each device when configuring an Inline station! It is specified in every terminal-specific data sheet. The current consumption can differ depending on the individual terminal. The permissible number of devices that can be connected therefore depends on the specific station structure.

Bus coupler supply U_{BK} ; Communications power U_L (7.5 V) and the analog supply U_{ANA} (24 V) are generated from the bus coupler supply.

Supply voltage	24 V DC (via Inline connector)
Supply voltage range	19.2 V DC ... 30 V DC (including all tolerances, including ripple)
Current consumption	min. 80 mA (without connected I/O terminal blocks) max. 0.98 A (with max. number of connected I/O terminal blocks)
Cable length	max. 30 m (do not route cable through outdoor areas)

Communications power (U_L)

Supply voltage	7.5 V DC
Power supply unit	max. 0.8 A DC

Supply of analog modules (U_{ANA})

Supply voltage	24 V DC
Supply voltage range	19.2 V DC ... 30 V DC (including all tolerances, including ripple)
Power supply unit	max. 0.5 A DC

Main circuit supply (U_M)

Supply voltage	24 V DC (via Inline connector)
Supply voltage range	19.2 V DC ... 30 V DC (including all tolerances, including ripple)
Power supply unit	max. 8 A DC (sum of $U_M + U_S$)
Current consumption	min. 3 mA (without connected peripherals) max. 8 A DC
Cable length	max. 30 m (do not route cable through outdoor areas)

Segment circuit supply (U_S)

Supply voltage	24 V DC (via Inline connector)
Supply voltage range	19.2 V DC ... 30 V DC (including all tolerances, including ripple)
Power supply unit	max. 8 A DC (sum of $U_M + U_S$)
Current consumption	min. 3 mA (without connected peripherals) max. 8 A DC
Cable length	max. 30 m (do not route cable through outdoor areas)

Power consumption

Power consumption	typ. 3 W (entire device)
-------------------	--------------------------

Protective circuit

Surge protection (segment supply, main supply, bus coupler supply)	Suppressor diode, 35 V DC
Reverse polarity protection (segment supply, main supply, bus coupler supply)	Suppressor diode, 35 V DC

Protection



NOTE: Electronics may be damaged when overloaded

Provide external protection for the 24 V areas U_{BK} , U_M , and U_S . If you are using an external fuse, the power supply unit must be able to supply four times the nominal current of the fuse. This ensures that it trips in the event of an error.

Digital inputs

Number of inputs	8
Connection method	Inline connector
Connection technology	3-conductor
Description of the input	EN 61131-2 type 1
Nominal input voltage	24 V DC
Nominal input current	typ. 3 mA
Current flow	Limited to 3 mA, maximum

Digital inputs	
Input voltage range "0" signal	-30 V DC ... 5 V DC
Input voltage range "1" signal	15 V DC ... 30 V DC
Delay at signal change from 0 to 1	typ. 1.2 ms
Delay at signal change from 1 to 0	typ. 1.2 ms
Permissible conductor length to the sensor	100 m

Digital outputs	
Number of outputs	4
Connection method	Inline connector
Connection technology	3-conductor
Nominal output voltage	24 V DC
Voltage difference with nominal current	< 1 V
Output current per channel	max. 500 mA
Output current of the device	max. 2 A
Nominal load, ohmic	12 W
Nominal load, inductive	12 VA (1.2 H, 48 Ω)
Nominal load, lamp	12 W
Limitation of the voltage induced on circuit interruption	approx. -30 V
Output current when switched off	max. 10 μA (When not loaded, a voltage can be measured even at an output that is not set.)
Signal delay	typ. 1.2 ms
Maximum operating frequency with inductive nominal load	0.5 Hz (1.2 H, 48 Ω)
Behavior at voltage switch-off	The output follows the power supply without delay
Short-circuit and overload protection	Freewheeling circuit in the output driver
Behavior with overload	Auto restart
Behavior with inductive overload	Output can be destroyed
Reverse voltage resistance to short pulses	Reverse voltage proof
Resistance to permanent reverse voltage	max. 2 A
Overcurrent shut-down	min. 0.7 A

Error messages to the higher level control or computer system	
Short-circuit or overload of the digital outputs	Yes
Sensor supply failure	Yes
Failure of the actuator supply	Yes

Electrical isolation/isolation of the voltage areas

Test section	Test voltage
Ethernet interface 1 / Ethernet interface 2	500 V AC, 50 Hz, 1 min.
Ethernet interface 1 / logic (U_{BK} , U_L , U_{ANA})	500 V AC, 50 Hz, 1 min.
Ethernet interface 1 / I/O (U_M , U_S)	500 V AC, 50 Hz, 1 min.
Ethernet interface 1 / functional ground	500 V AC, 50 Hz, 1 min.
Ethernet interface 2 / logic (U_{BK} , U_L , U_{ANA})	500 V AC, 50 Hz, 1 min.
Ethernet interface 2 / I/O (U_M , U_S)	500 V AC, 50 Hz, 1 min.
Ethernet interface 2 / functional ground	500 V AC, 50 Hz, 1 min.
Communications power (U_{BK} , U_L , U_{ANA}) / I/O (U_M , U_S)	500 V AC, 50 Hz, 1 min.
Communications power (U_{BK} , U_L , U_{ANA}) / functional ground	500 V AC, 50 Hz, 1 min.
I/O (U_M , U_S) / functional ground	500 V AC, 50 Hz, 1 min.



To achieve electrical isolation between the logic level and the I/O area, supply these areas from separate power supply units. Interconnection of the power supply units in the 24 V area is not permitted (see IL SYS INST UM E user manual).

Mechanical tests

Vibration resistance in accordance with EN 60068-2-6/ IEC 60068-2-6	5g
Shock in accordance with EN 60068-2-27/IEC 60068-2-27	Operation: 25g, 11 ms duration, semi-sinusoidal shock impulse

Conformance with EMC Directive 2014/30/EU

Immunity test in accordance with EN 61000-6-2/IEC 61000-6-2

Electrostatic discharge (ESD) EN 61000-4-2/IEC 61000-4-2	Criterion B, 6 kV contact discharge, 8 kV air discharge
Electromagnetic fields EN 61000-4-3/IEC 61000-4-3	Criterion A, Field intensity: 10 V/m
Fast transients (burst) EN 61000-4-4/IEC 61000-4-4	Criterion A, all interfaces 1 kV Criterion B, all interfaces 2 kV
Transient overvoltage (surge) EN 61000-4-5/IEC 61000-4-5	Criterion B, supply lines DC: 0.5 kV/0.5 kV (symmetrical/ asymmetrical) (see IL SYS INST UM E user manual), fieldbus cable shield 1 kV
Conducted interference EN 61000-4-6/IEC 61000-4-6	Criterion A, Test voltage 10 V

Noise emission test in accordance with EN 61000-6-4/IEC 61000-6-4 Class A

Approvals

For the current approvals, go to: www.phoenixcontact.net/product/2703981



Items manufactured **until the start of 2023** comply with directive 2014/34/EU (ATEX). You may use these items in potentially explosive areas of category 3.

Items manufactured **afterwards** do **not** meet the requirements of directive 2014/34/EU. Use in potentially explosive areas of category 3 is **not permitted**.

If you use an item with ATEX-relevant printing in a potentially explosive area, please observe the associated documentation.

Please also observe the specifications in the AH DE IL EX ZONE 2 (German) or AH EN IL EX ZONE 2 (English) application note.

If the item used by you does not feature ATEX-relevant identification, use in potentially explosive areas is not permitted.

Manufacturer's declarations

For the current manufacturer's declarations, go to: www.phoenixcontact.net/product/2703981

5 Internal circuit diagram

Figure 1 Internal wiring of connections

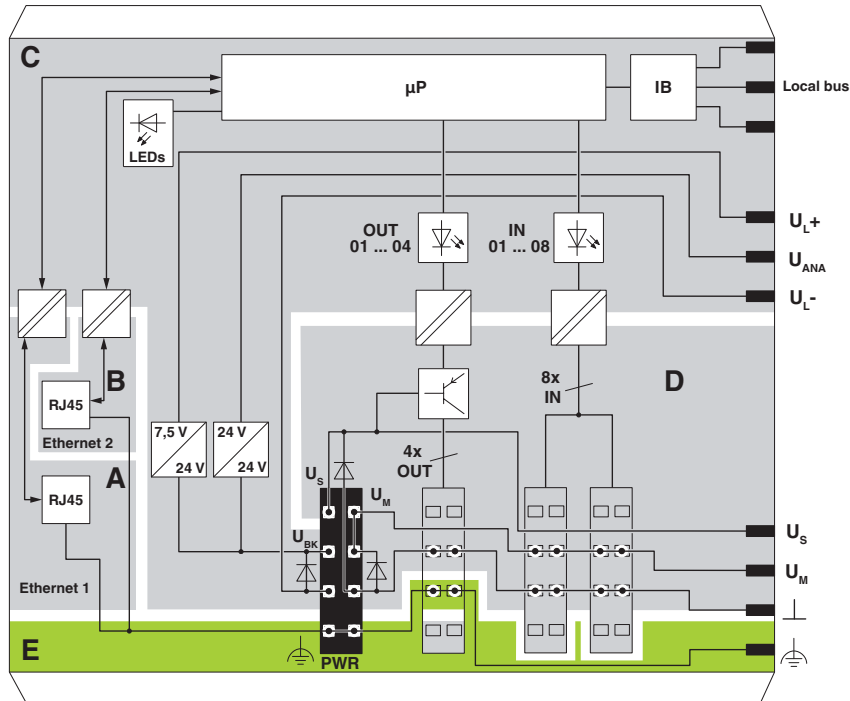

Key:



Microprocessor



Protocol chip



LED



Electrical isolation for data or power supply



RJ45 interface



Power supply unit



PNP transistor



Electrically isolated areas



Other symbols used are explained in the IL SYS INST UM E user manual.

Electrically isolated areas when using separate power supply units to supply U_{BK} and U_M/U_S :

A/B Ethernet 1/2

C Logic

D I/O devices

E Functional ground

6 Security in the network



NOTE: Risk of unauthorized network access

Connecting devices to a network via Ethernet entails the danger of unauthorized access to the network.

To prevent unauthorized network access, please read the following notes.

If possible, deactivate unused communication channels.

Assign passwords such that third-parties cannot access the bus coupler and make changes without authorization.

Due to its communication interfaces, the bus coupler should not be used in safety-critical applications without additional security appliances.

Therefore, please take additional protective measures in accordance with the IT security requirements and the standards applicable to your application (e.g. virtual networks (VPN) for remote maintenance access, firewalls, etc.) for protection against unauthorized network access.

On first request, you shall release Phoenix Contact and the companies associated with

Phoenix Contact GmbH & Co. KG, Flachmarktstrasse 8, 32825 Blomberg in accordance with §§ 15 ff. AktG (German Stock Corporation Act), hereinafter collectively referred to as "Phoenix Contact", from all third-party claims made due to improper use.

For the protection of networks for remote maintenance via VPN, Phoenix Contact offers the mGuard product series as security appliances; these are described in the latest Phoenix Contact catalog (www.phoenixcontact.net/products).

Additional measures for protection against unauthorized network access can be found in the AH EN INDUSTRIAL SECURITY application note. The application note can be downloaded at www.phoenixcontact.net/products.

7 Connecting Ethernet, the supply, actuators, and sensors

7.1 Connecting Ethernet

Connect Ethernet to the bus coupler via an 8-pos. RJ45 connector.

The Ethernet connections are set to autocrossing.



Shielding

The shield of the connected twisted pair cables is electrically connected to the socket. When connecting network segments, avoid ground loops, potential transfers, and equipotential bonding currents via the braided shield.



Observe bending radii

The housing dimensions specified under "Dimensions" refer to the bus coupler with I/O connectors without Ethernet connection. When installing the bus coupler in a control box, observe the bending radii of the Ethernet cables and the connectors used (e.g., FL CAT5 FLEX: 30 mm for fixed installation and FL CAT5 HEAVY: 30 mm without outer sheath and 45 mm with outer sheath). If required, use angled RJ45 connectors to maintain these bending radii.

7.2 Connecting the supply, actuators, and sensors - terminal point assignment

Figure 2 Terminal point assignment

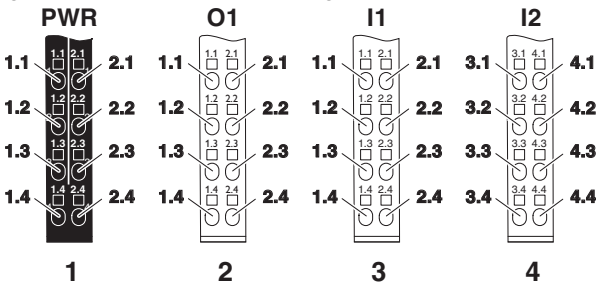

Terminal point assignment of the power plug PWR (1)

Terminal point	Assignment	Terminal point	Assignment
1.1	U_S	2.1	U_M
1.2	U_{BK}	2.2	U_M
1.3	GND U_{BK}	2.3	GND U_M, U_S
1.4	Functional ground FG	2.4	Functional ground FG



NOTE: Malfunction

The module is designed exclusively for SELV operation according to IEC 950/EN 60950/VDE 0805.



For information on the power supplies, please refer to the IL SYS INST UM E user manual.



If you wish to use the same reference potential for communications power and segment voltage, you can bridge terminal points 1.3 and 2.3 on the connector.



Make sure that the maximum total current flowing through the potential jumpers is 8 A.



Connect the functional ground via the power connector.

Terminal point assignment of the output plug O1 (2)

Terminal point	Assignment	Terminal point	Assignment
1.1	OUT01	2.1	OUT02
1.2	GND	2.2	GND
1.3	FE	2.3	FE
1.4	OUT03	2.4	OUT04

Terminal point assignment of the input plug I1 (3)

Terminal point	Assignment	Terminal point	Assignment
1.1	IN01	2.1	IN02
1.2	U_M	2.2	U_M
1.3	GND	2.3	GND
1.4	IN03	2.4	IN04

Terminal point assignment of the input plug I2 (4)

Terminal point	Assignment	Terminal point	Assignment
3.1	IN05	4.1	IN06
3.2	U_M	4.2	U_M
3.3	GND	4.3	GND
3.4	IN07	4.4	IN08

8 Connection example

Figure 3 Connection example

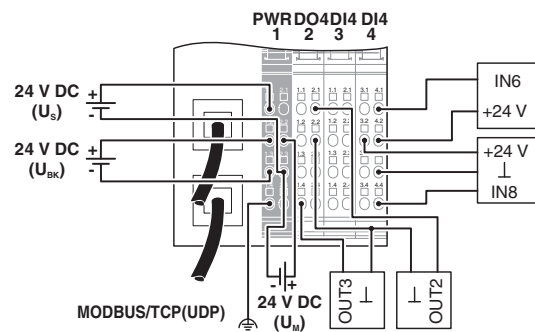

9 Local diagnostic and status indicators

Figure 4 Local diagnostic and status indicators

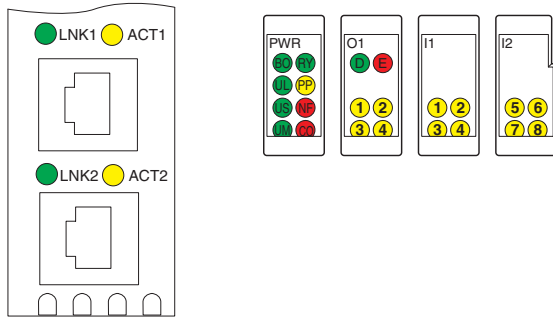

Designation	Color	Meaning	State	Description
ETH				
LNK 1/2	Green	Link port 1/2	On	Connection via Ethernet to a module via port 1/2 established
			Off	No connection established via port 1/2
ACT 1/2	yellow	Activity port 1/2	Flashing	Transmission or reception of Ethernet telegrams at port 1/2
			Off	No transmission or reception of Ethernet telegrams at port 1/2
PWR/ETH				
BO	Green	Boot	Off	System startup completed
			Flashing	Waiting for BootP/DHCP reply
			On	Boot loader active, firmware started
UL	Green	U _{Logic}	Off	24 V bus coupler supply not present
			On	24 V bus coupler supply present
US	Green	U _{Segment}	Off	24 V segment supply not present
			On	24 V segment supply is present
UM	Green	U _{Main}	Off	24 V supply is not present in the main circuit
			On	24 V supply is present in the main circuit
RY	Green	Ready	On	Connection to a process data client established
			Flashing	Firmware ready to operate
			Off	Device is not ready for operation.
PP	Yellow	Plug and Play mode	On	Plug and Play mode is activated.
			Off	Plug and Play mode is deactivated.
NF	Red	Network Failure	Off	Network error
			Off	No network error, normal state
			On	A network error has occurred. The monitoring function detected an error or the process data watchdog was activated.
CO	Red	Configuration	Off	The active configuration of the local bus matches the saved configuration.
			On	The active configuration of the local bus differs from the saved configuration.

Designation	Color	Meaning	State	Description
O1: diagnostics of the Inline station/diagnostics and status of the outputs				
D	Green	Diagnostics	On	Data transmission active within the station
			Flashing	Data transmission not active within the station
E	Red	Error	On	Short circuit/overload at one or more outputs
			Off	No short circuit and no overload at the outputs
1 ... 4	Yellow	Status of outputs 1 ... 4	On / Off	Output is set/not set.
I1, I2: status of the inputs				
1 ... 8	Yellow	Status of the inputs 1 ... 8	On / Off	Input is set/not set.

10 Reset button

The reset button is on the front of the bus coupler.

The reset button has two functions:

- Restarting the bus coupler
- Resetting of the default settings

10.1 Restarting the bus coupler

Restart the bus coupler by pressing the reset button during ongoing operation.

The outputs of the station are reset.

The process image of the inputs is not re-read.

10.2 Resetting to the default settings

The bus coupler is supplied with the following default settings:

IP settings

IP address	0.0.0.0
Subnet mask	0.0.0.0
Default gateway	0.0.0.0
BootP	activated

Firmware update

Firmware update on next restart	deactivated
TFTP server IP address	0.0.0.0
Name of firmware update file	c2703981.fw

System identification

Name of device	IL ETH BK DI8 DO4 2TX-PAC
Description	Ethernet bus terminal
Location	unknown
Contact	unknown

Process data monitoring

Process data watchdog time-out	500 ms
Fault response mode	Reset fault mode (Default)

Plug and Play mode activated

Expert mode deactivated

Delayed startup deactivated

(firmware version 1.42 or later)

On-board inputs and outputs activated

(firmware version 1.42 or later)

If you wish to restore the default settings, proceed as follows:

- Disconnect the power to the module.
- Press and hold the reset button.
- Switch on the power.
- When the RY LED flashes green, release the button.

The default settings are restored.

11 Startup

11.1 Starting the firmware



By default, the bus coupler has no valid IP parameters.

The firmware is started after you have supplied power to the bus coupler.

The following LED sequence is displayed:

Display	Meaning
BO flashing	Starting the boot loader Sending BootP requests
BO on	Extracting the firmware
BO off	Starting firmware
RY flashing	Firmware ready to operate

11.2 Sending BootP requests

Initial startup

During initial startup, the device sends BootP requests without interruption until it receives a valid IP address. The requests are transmitted at varying intervals (2 s, 4 s, 8 s, 2 s, 4 s, etc.) so that the network is not unnecessarily burdened. If the device receives valid IP parameters, it saves them as configuration data.

Restart

If the bus coupler already has valid configuration data and BootP is not disabled, it only transmits three more BootP requests during a restart. If it receives a BootP reply, the new parameters are saved. If the bus coupler does not receive a response, it starts with the previous configuration. If BootP is disabled and a valid configuration is available, the bus coupler starts immediately.



You can use any BootP server to assign the IP address via BootP.



You can see whether BootP is disabled in the "IP Configuration" menu in web-based management.

12 Startup behavior of the bus coupler

The startup behavior of the bus coupler is determined by the following system parameters:

Parameter	Var ID (hex)	Delivery state
Plug and Play mode	2240	Activated
Expert mode	2275	Deactivated
Delayed startup (firmware version 1.42 or later)	2278	Deactivated

12.1 Plug and Play mode



This description is applicable only when expert mode is disabled.

Plug and Play mode active

The bus coupler supports Plug and Play mode.

In Plug and Play mode, you can use the bus coupler to start up the connected local bus modules in the field without a higher-level PC (engineering system).

The Plug and Play mode status (active or inactive) is stored retentively on the bus coupler. The current mode is displayed via the PP LED.

In plug-and-play mode, the connected local bus modules are detected (type and installation sequence).

If this physical configuration is ready to operate, it is started; however, writing outputs is not enabled.



To enable writing outputs, Plug and Play mode must be deactivated. The deactivation is to be saved at the same time as saving the signal, active configuration, and reference configuration.

Plug and Play mode inactive

When plug and play mode is deactivated, the reference configuration is compared to the physical configuration. If the configurations are identical, the bus coupler is set to the RUN state on the first write access.

If the reference configuration and the physical configuration differ, the LED CO lights up red. In this case, process data exchange is not possible for safety reasons.

In order to operate the bus despite this, you have the following two options:

1. Restore the original configuration so that the reference configuration and the physical configuration are the same again.
2. Activate plug-and-play mode and restart the bus coupler so that the active physical configuration is accepted as the reference configuration.

12.2 Expert mode

Expert mode disabled

If expert mode is disabled (default upon delivery), the bus coupler runs in plug-and-play mode.

Expert mode enabled

If expert mode is enabled, the bus is not started automatically. You must set the station to the "RUN" state using the appropriate firmware commands. Suitable firmware commands include e. g. CREATE_CONFIGURATION, 0710_{hex} and START_DATA_TRANSFER, 0701_{hex}. The PP and CO LEDs are not used.

12.3 Delayed startup (delayed start data transfer)

Firmware version 1.42 or later.

Delayed startup deactivated

If delayed startup is deactivated (delivery state), then the bus coupler works as described in the section "Plug-and-play mode".

Delayed startup activated

If delayed startup is activated, data transmission to the local bus is only activated once the controller first receives write access for the process data. Alternatively, you can activate data transmission using the command "Clear Net Fail".

The LED D will initially show the status "ACTIVE" (flashing).

This option makes it possible for local bus devices to directly specify valid process data after the bus coupler is restarted.



Note the following for the time until the start of data transmission:

- PCP transfer is not possible.
- The input process data is not valid.



If a station only contains input terminals, note the following:

You must first start the data transfer (as described above). Only then can you read valid input process data.

Recommendation: If your station only contains input terminals, do not activate this option.

12.4 Possible combinations of modes

Plug and Play mode	Expert mode	Description/effect
Deactivated	Deactivated	Normal case. The station sets the valid configuration to the "RUN" state. The process data exchange is possible.
Activated	Deactivated	The connected configuration is stored as the reference configuration and the station is set to the "RUN" state. Process data cannot be written.
Any	Activated	The bus is not started automatically, instead it waits for firmware commands from the user.

12.5 Startup diagrams for the bus coupler

Figure 5 Normal mode. Plug and Play mode and expert mode deactivated

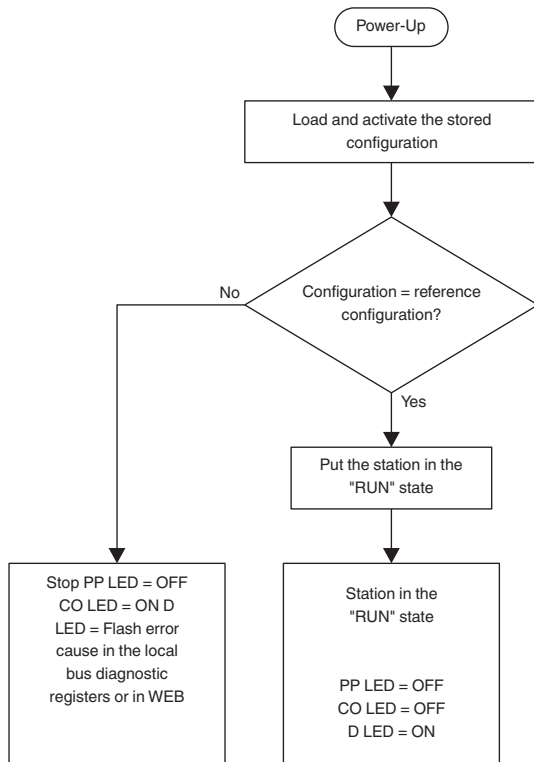
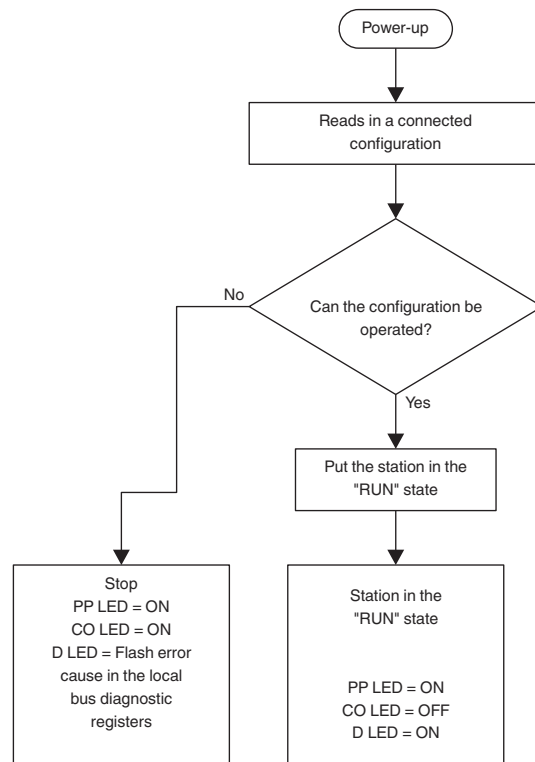

Figure 6 Plug and Play mode activated and expert mode deactivated



When you have disabled expert mode, restart the bus coupler. The modification only takes effect after a restart.



If you have activated the delayed startup, the station is not immediately switched to the "RUN" state, but rather initially switches to the "ACTIVE" state (LED D flashes). Once you have written process data for the first time or executed the command "Clear Net Fail", the station switches to the "RUN" state (LED D on).

12.6 Changing and starting a configuration in plug-and-play mode



Ensure that plug-and-play mode is enabled and expert mode is disabled.

Changing the existing configuration

Proceed as follows to change an existing configuration:

- Switch off the supply voltage.
- Change the physical configuration.
- Switch on the supply voltage.

Starting up a configuration

Startup is carried out as described in the preceding section. Please note:

- If there are no errors, after the bus coupler has been switched on, it reads in the previously found configuration and starts it.
- If the D LEDs are continuously lit on all terminals, all devices are integrated into the current configuration.
- To prevent you from accidentally working with an incorrect configuration, it is only possible to access the process data when plug-and-play mode has been disabled.



When plug-and-play mode is enabled, access to process data is denied with the error message 00A9_{hex} (ERR_PLUG_PLAY). The outputs of the entire InLine station are reset in plug-and-play mode.

You have various options for switching off plug-and-play mode:

- Web-based management
- Modbus command register
- "Set_Value" command



Once plug-and-play mode has been switched off, the bus is only started if the existing configuration and the reference configuration are the same.

13 Monitoring

Various functions are available for monitoring the Ethernet communication:

- Process data watchdog (process data monitoring)
- Connection monitoring for Modbus and DTI

The monitoring functions differ according to the features and functions that need to be monitored. Depending on the application requirements, the appropriate monitoring function can be activated. The process data watchdog is deactivated by default upon delivery.

Monitoring mechanism	Monitored property/function			
	Client application	Individual channels	Ethernet connection	Process data exchange
Process data watchdog	X	-	X	X
Connection monitoring for Modbus and DTI	X	X	X	-

If the monitoring function has detected an interruption, substitute value behavior is activated. See "Substitute value behavior (fault response mode)" section.

13.1 Setting the fault response mode

There are various options available for configuring the desired substitute value behavior:

- Web-based management
- Writing to Modbus register 2002
- "Set_Value" service for the variable 2277_{hex}

Possible values for the substitute value behavior

Fault response mode	Value	Function
Standard fault mode	0	Set all outputs to 0.
Reset fault mode (Default)	1	Terminal-specific substitute value (see data sheet for the I/O terminal). Typical behavior: Set digital outputs to 0. Set analog outputs to the default value.
Hold last state mode	2	All outputs keep their last value.

13.2 Process data watchdog / process data monitoring



By default upon delivery, the process data watchdog is activated with a timeout of 500 ms.

Function of the process data watchdog

A process data watchdog is integrated into the bus coupler to avoid uncontrolled setting or resetting of the I/O station outputs in the event of an error.

If station outputs are set, the controlling process must be able to access the station.

In the event of an error, e. g. a network cable is interrupted or there is a function error in the controlling process, the bus coupler can respond appropriately via the process data watchdog.

When you activate the process data watchdog, it is started by the first write process. It expects the next write process within the timeout period. In error-free operation, the write process is performed during the timeout period. The watchdog is then restarted (triggered).

By default upon delivery, the watchdog is activated with a 500 ms timeout.



Reading calls do not trigger the process data watchdog.

Net fail

If there is no triggering during the timeout period, an error has occurred. Two responses follow:

- The selected fault response mode is run.
- The Net Fail signal is set (the NET LED is red).

The reason for setting the net fail signal is listed in the reason code.

For safety reasons, the user cannot stop the watchdog once it has been activated. If the user terminates the controlling application, the watchdog is not triggered. When the timeout period elapses, the Net Fail signal is set and the selected fault response mode is run. After the watchdog has been triggered, the outputs are enabled again only after acknowledgment.

Acknowledge error message

To reset the error, it must be acknowledged.

The following options are available:

- Web-based management
- Modbus register 2006



When the error is acknowledged, the watchdog is restarted. This means that it must be triggered during the time-out period, otherwise an error is detected again.

Configuring the process data watchdog

You can change timeout periods only if the watchdog is in the "INIT" state. This state is present in the following cases:

- After power-up, as long as no process data exchange has taken place.
- When a timeout has occurred, the fault response has been activated and Net Fail has not yet been acknowledged.
- To activate the watchdog, specify the desired time-out value in the range between 200 ms and 65000 ms.
- To deactivate the watchdog, specify the value 0.

You have the following options for changing the time-out period:

- Web-based management
- Modbus register 2000
- "Set_Value" service for the variable 2293_{hex}

Acknowledging a fault response

You can acknowledge the Net Fail signal with the following mechanisms:

- Web-based management
- Writing the 0002_{hex} command to the command register 2006
- "ETH_ClrNet FailStatus" function

Reasons for a Net Fail

You can query the reasons for setting the Net Fail signal via:

- Web-based management
- Modbus register 2004
- DDI function "ETH_GetNet FailStatus"

The following causes are possible:

Cause		Code (hex)
DDI_NF_TASK_CREAT_ERR	Error when starting a task	0001
DDI_NF_LISTENER_ERR	Listener task error	0002
DDI_NF_RECEIVER_ERR	Receiver task error	0003
DDI_NF_ACCEPT_ERR	Accept function error	0004
DDI_NF_ECHO_SERVER_ERR	Echo server task error	0005
DDI_NF_HOST_CONTROLLER_ERR	Host controller task error	0006
DDI_NF_DTI_TIMEOUT	DTI time-out occurred	0007
DDI_NF_HOST_TIMEOUT	Host time-out occurred	0008
DDI_NF_USER_TEST	Net Fail set by user	0009
DDI_NF_CONN_ABORT	Connection aborted	000A
DDI_NF_INIT_ERR	Initialization error	000B
DDI_NF_DTI_WATCHDOG	Process data watchdog triggered	000C
DDI_NF_MBUS_TIMEOUT	Modbus time-out occurred	000D

14 Modbus protocols and registers

The bus coupler supports a Modbus/TCP server and a Modbus/UDP server.

The Modbus protocol can be used in both in a connection-related (TCP) and wireless (UDP) manner.

14.1 Modbus connections

Modbus/TCP

The bus coupler supports up to eight Modbus/TCP connections simultaneously.

The connection can access different addresses simultaneously.

If a connection over SDDI is used and simultaneously a connection to the static table is opened, the SDDI connection is aborted with the error code `xxxx00AAhex`. The SDDI connection can only be reestablished after a bus coupler reset. Simultaneous connections over SDDI and Modbus dynamic tables are not write-protected. Writing to static and dynamic tables is protected with semaphores.

Since eight connections are supported, a connection can quickly be restored. This means that the client can successfully restore an interrupted Modbus connection.

Modbus/UDP

The UDP server is wireless.

14.2 Modbus interface

The Modbus interface of the bus coupler supports Modbus communication in accordance with standard port 502.

14.3 Modbus conformance classes

The bus coupler supports Modbus conformance class 0.

14.4 Modbus function codes

The following function codes are supported:

Function code	Function	Description
FC3	Read holding registers	Read words from outputs and inputs
FC4	Read input registers	Read words from inputs
FC6	Write single registers	Write word for output data
FC16	Write multiple registers	Write several output words
FC23	Read/write multiple registers	Read and write several process data for inputs and outputs

14.5 Modbus register

Modbus register table (16-bit word)	Access	Function	Access with function code
Local bus			
1400	R	Number of local bus devices/entries	FC3, FC4
1401 ... 1463	R	ID code and length code of the relevant device	
Special register			
1280	R/W	Timeout of the monitoring of the Modbus/TCP connections	FC3, FC4, FC6, FC16
2000	R/W	Time-out for process data watchdog	FC3, FC4, FC6, FC16
2002	R/W	Fault response mode	FC3, FC4, FC6, FC16
2004	R	Net fail reason	FC3, FC4
2006	W	Command register	FC6, FC16
2008	R/W	Delayed start data transfer (firmware version 1.42 or later)	FC3, FC4, FC6, FC16
2010	R/W	On-board inputs and outputs (firmware version 1.42 or later)	FC3, FC4, FC6, FC16
PCP			
6020 ... 6173	R/W	CR 2 ... CR 17 (see "Modbus/TCP PCP Registers")	FC3, FC4, FC16
2075 ... 2089	R	Electronic rating plate (firmware version 1.42 or later)	FC3, FC4
Diagnostics			
7996	R	Status register	FC3, FC4, FC23
7997	R	Diagnostic status register	
7998	R	Diagnostic parameter register 1	
7999	R	Diagnostic parameter register 2	
Process data (dynamic table)			
8000	R	Local digital inputs	FC3, FC4, FC6, FC16, FC23
8001 ... (8000+x)	R	Local bus inputs (x words)	
(8001+x)	R/W	Local digital outputs	
(8002+x) ... (8001+x+y)	R/W	Local bus outputs (y words)	

Modbus register table (16-bit word)	Internal tables IL ETH BK ... (16-bit word)	Access	Function	Access with function code
Process data (static table)				
0 ... 191	%I1 ... 192	R	Digital inputs	FC3, FC4, FC23
192 ... 383	%AI1 ... 192	R	Analog inputs	FC3, FC4, FC23
384 ... 575	%Q1 ... 192	R/W	Digital outputs	FC6, FC16, FC23
576 ... 767	%AQ1 ... 192	R/W	Analog outputs	FC6, FC16, FC23

R Read
W Write

14.6 Assignment of process data

Figure 7 Example for the location of process data in dynamic tables

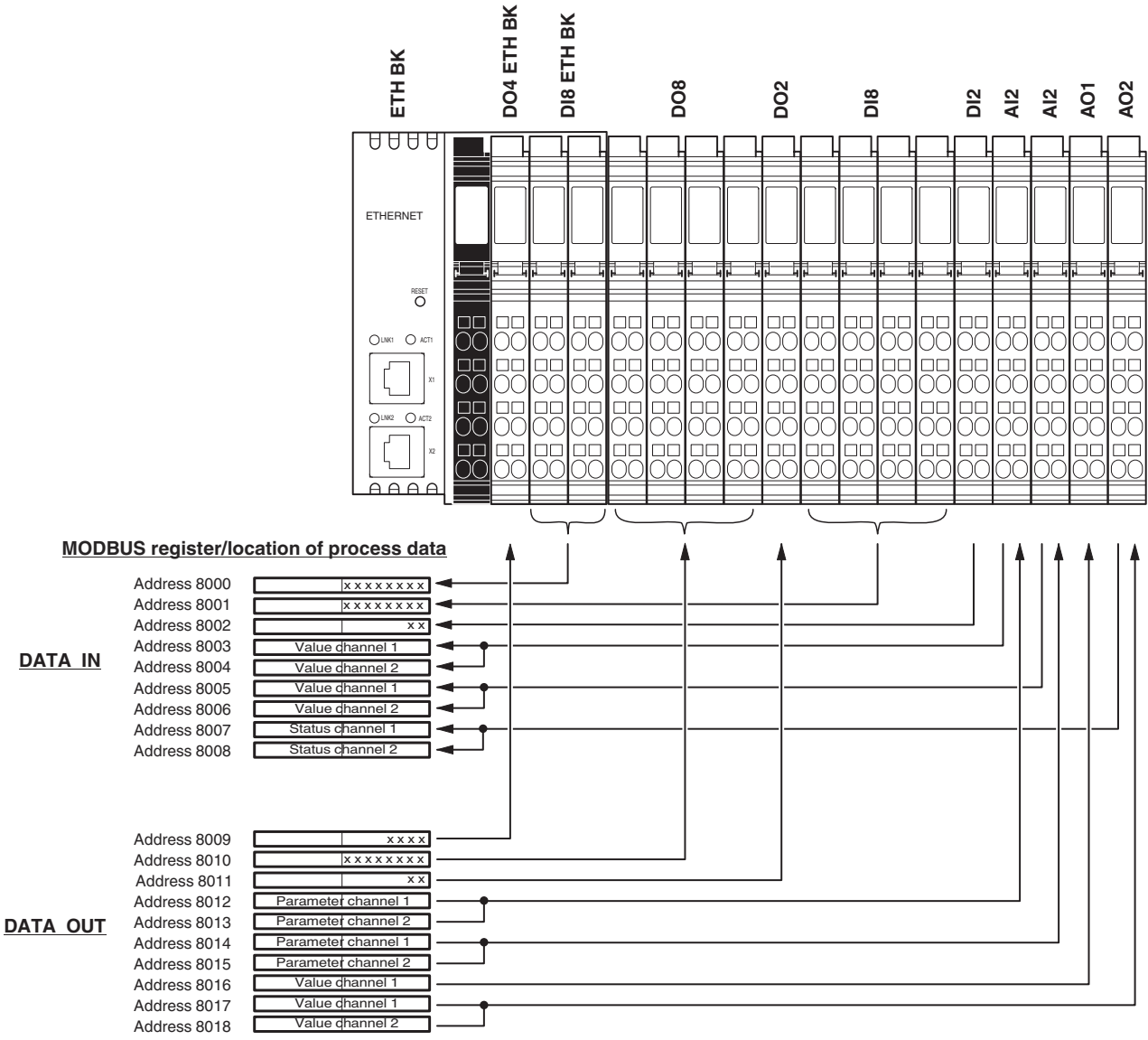
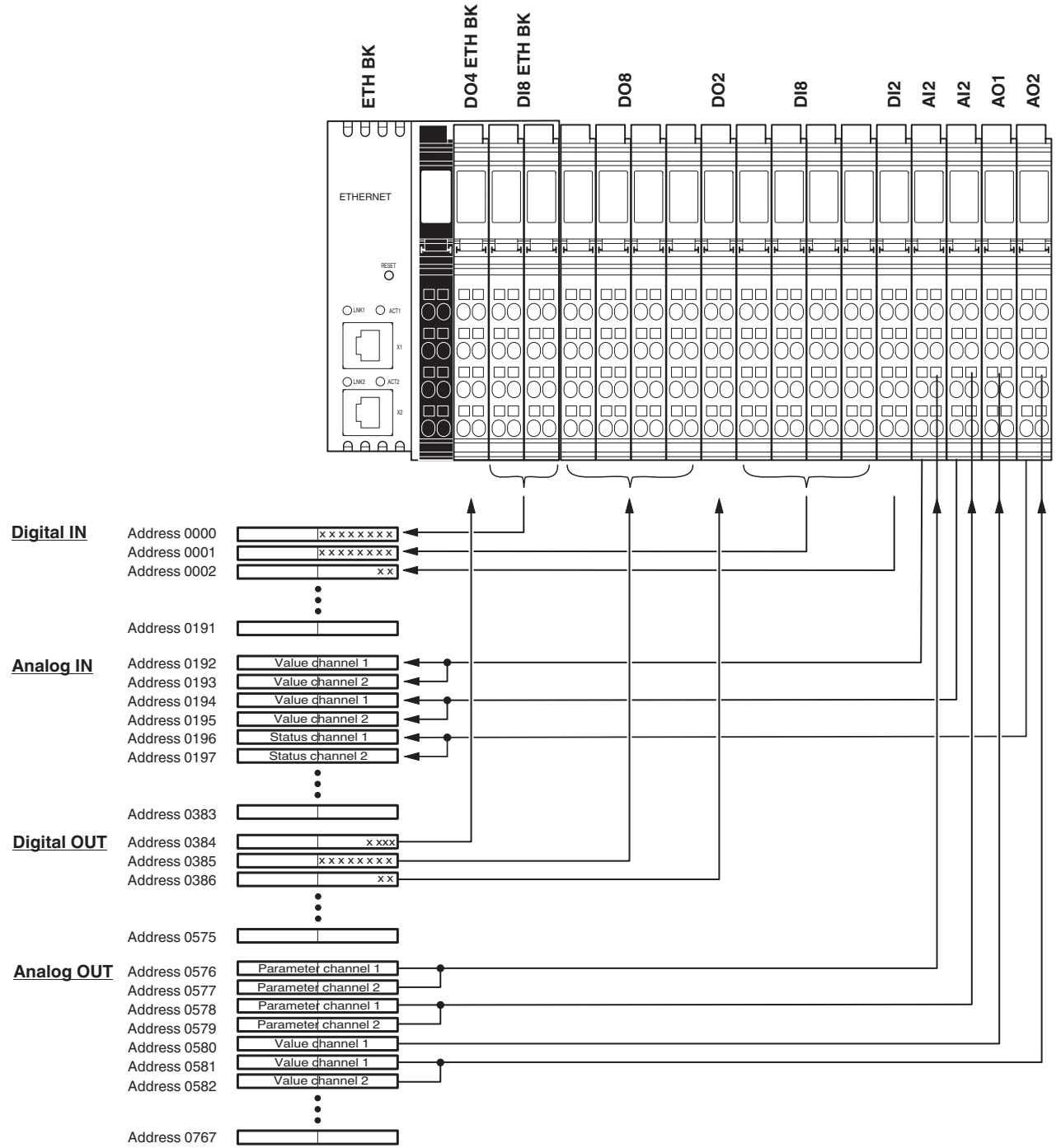

Figure 8 Example for the location of process data in static tables



14.7 Local bus configuration (1400 ... 1463)

The bus coupler makes the local bus configuration available in these registers.

Index	Contents	
1400	Number of local bus devices	
1401 ... 1463	Length code/ID code of the device	
	Byte 0	Length code
	Byte 1	ID code

The ID code is imprinted as a decimal value as "Module ID" on every Inline terminal and describes the function of the terminal.

The length code indicates a code for the process data width. To find out how to get the process data width from the code, please refer to the IBS SYS FW G4 UM E user manual. Round the determined data length to 16 bits so that the process data fits in the Modbus/TCP registers.

Example:

Inline terminal	IB IL 24 DI 8-PAC
Length code	81 _{hex}
ID code	BE _{hex} (190 _{dec})
According to the IBS SYS FW G4 UM E user manual:	
Data length	Byte
Quantity	1
Round up to 16-bit register:	1 word in the Modbus/TCP process data table

14.8 Process data watchdog timeout (2000)

You can use this register to set or read the timeout value for the process data watchdog. The time is specified in milliseconds in the range from 200 ms to 65,000 ms. A timeout value of 0 deactivates the watchdog.

14.9 Substitute value behavior (fault response mode) (2002)

You can use this register to set or read the fault response mode. For information on configuring settings, refer to the Section "Setting the fault response mode".

14.10 Net Fail reason (2002)

You can use this register to read the reason after setting the Net Fail signal. If there is no Net Fail signal, the register is 0.

14.11 Command register (2006)

You can use the network interface command register to transmit commands with basic functions to the bus coupler using the Ethernet host controller. An Ethernet host controller can be, for example, a PLC.

Command word

Bit	15 ... 3	2	1	0
Assignment	Reserved	CPF	CNF	PP

Meaning

CPF	Clear peripheral fail error	Clear peripheral fault		
CNF	Clear net fail	Delete Net Fail		
PP	Plug and Play mode	0	Switch off Plug and Play mode	
		1	Switch on Plug and Play mode	

14.12 Delayed start data transfer (2008)

Firmware version 1.42 or later.

You can use this register to activate or deactivate delayed start data transfer on the local bus.

Options include:

- 0 Delayed startup deactivated (default)
- 1 Delayed startup activated

Changes to the settings are only applied after the bus coupler is restarted.

See section "Startup behavior of the bus coupler".

14.13 On-board inputs and outputs (2010)

Firmware version 1.42 or later.

You can use this register to activate or deactivate on-board inputs and outputs.

Options include:

- 0 Deactivate on-board inputs and outputs
- 1 Activate on-board inputs and outputs (default)

14.14 Electronic rating plate (2075 ... 2089)

The electronic rating plate contains the basic information on the module.

Only read access is enabled to the registers.

These registers should be seen as an object index and can be longer than 2 bytes. Therefore only access the registers one after another.

Modbus register	Function	Maximum length of the register in bytes
2075	Name of device	250
2076	Description	250
2077	Location	250
2078	Contact	250
2079	Boot loader version	4
2080	Firmware version	6
2081	Firmware status	8
2082	Hardware version	8
2083	Firmware date	8
2084	Hardware date	8
2085	Serial number	20
2086	MAC address	18
2087	Item No.	20
2088	Order designation	32
2089	Vendor name	20

14.15 Diagnostic registers (7996 ... 7999)

The diagnostic registers provide an overview of the general operating state of the bus coupler and the connected devices. In order to respond quickly in the event of an error, the error source and sometimes even the exact error location are specified.

Overview:

Modbus register (16-bit word)	Access	Function	Access with function code
Diagnostics			
7996	R	Status register	FC3, FC4, FC23
7997	R	Diagnostic status register	FC3, FC4, FC23
7998	R	Diagnostic parameter register 1	FC3, FC4, FC23
7999	R	Diagnostic parameter register 2	FC3, FC4, FC23

14.15.1 Status register (7996)

Using the Ethernet host controller, e. g., a PLC, you can read current diagnostic information from the network interface status word without the need for configuration software.

Only the two least significant bits (bit 0 and bit 1) have a function. Bits 2 to 15 are reserved.

This register should be monitored cyclically in order to quickly determine whether an error is present at the bus coupler. The following diagnostic registers can be used for further diagnostics.

Bit	Value	Meaning
0	0	An error occurred, e.g., a bit in the diagnostic status register is set. For further information, please refer to register 7997.
	1	No errors have occurred.
1	0	No Net Fail occurred.
	1	A Net Fail occurred, substitute values are active.

14.15.2 Diagnostic status register (7997)

Each bit in the diagnostic status register for the local bus is assigned a state of the local bus master on the bus coupler. The states in the error bits (USER, PF, BUS, CTRL) are described in greater detail using the diagnostic parameter register. The diagnostic parameter register is rewritten whenever one of the aforementioned error bits is set. Otherwise, the diagnostic parameter register contains the value 0000_{hex}.

Bit	Designation	Meaning
0	USER_BIT	Application program error.
1	PF_BIT	Local bus device has detected a peripheral fault.
2	BUS_BIT	Error in the local bus.
3	CTRL_BIT	Local bus master has an internal error.
4	DETECT_BIT	Error localization ("LOOK FOR FAIL")
5	RUN_BIT	Data cycles are exchanged.
6	ACTIVE_BIT	Local bus master is in the ACTIVE state.
7	READY_BIT	Local bus master is in the READY state, self-test is completed.

READY, ACTIVE, RUN status displays

The READY, ACTIVE, and RUN status displays show the current state of the local bus system.

The diagnostic parameter register is not used.

After the self-test, the local bus master is ready for operation.

The READY indicator bit is set (READY_BIT = 1).

If the local bus master has been configured and the configuration frame has been activated without errors, the system indicates that it is active.

The READY and ACTIVE indicator bits are set (READY_BIT = 1, ACTIVE_BIT = 1).

In addition, the RUN indicator bit is set (READY_BIT = 1, ACTIVE_BIT = 1 and RUN_BIT = 1) when the data exchange is started.



Errors are displayed until they are acknowledged.

DETECT, CTRL, BUS, PF, USER error indicators

The DETECT error bit shows that an error is preventing further operation of the local bus (DETECT = 1). The outputs are set to the terminal-specific substitute values. The diagnostic routine searches for the error cause.

Once the error cause has been detected, the DETECT error bit is reset (DETECT = 0) and the error is indicated in the USER, PF, BUS and CTRL bits. The diagnostic parameter register and the extended diagnostic parameter register provide a detailed description of the error cause.

Error with local bus shutdown

Error bit	Error location	Contents of the diagnostic parameter register
CTRL = 1	Probably a local bus master/hardware error.	Error code
BUS = 1	The error affects a local bus segment.	Error location

Error without local bus shutdown

Error bit	Error location	Contents of the diagnostic parameter register
PF = 1	Fault on the peripheral side of a local bus device, e. g. short-circuit at the output, sensor/actuator power supply missing	Error location
USER = 1	User error, e. g., due to incorrect parameters	Error code

14.15.3 Diagnostic parameter register 1 (7998)

In the case of localized local bus errors, diagnostic parameter register 1 for the local bus provides the error location.

Error location: e. g., device number 0.3
means: bus segment 0, device 3

Byte	n	n + 1
Bit	7 ... 0	7 ... 0
Contents	00	03
Meaning	Segment number	Position in the segment

14.15.4 Diagnostic parameter register 2 (7999)

Diagnostic parameter register 2 for the local bus contains additional information about the error codes.

14.16 Modbus connection timeout (1280)

A monitoring mechanism can be activated for every Modbus/TCP connection in order for the bus coupler to detect an error in the network (e. g., a faulty cable) or in the client (operating system crash or error in the TCP/IP protocol stack) and respond accordingly.

The monitoring mechanism is activated via the relevant TCP connection upon the first read or write procedure.

To change the timeout value for the relevant TCP connection, write the new timeout value in the timeout table at the special address in register 1280. Use “fc 6” or “fc 16” functions for this. The value of this entry is the value of the timeout table. The time is specified in milliseconds in the range from 200 ms to 65000 ms.

A timeout value of 0 deactivates the monitoring function. Values between 1 ms and 199 ms, and values greater than 65,000 ms generate exception response 3 (ILLEGAL DATA VALUE).



Connection monitoring with the new timeout values is only activated after a Modbus/TCP function has been run on the relevant TCP connection.

After the first access by a Modbus/TCP function, all other access must be carried out using the entered timeout value. Otherwise, the substitute value behavior is activated and the corresponding Modbus/TCP connection is disabled.

14.17 Modbus/TCP PCP registers

The PCP registers are divided into two classes:

- Communication registers for exchanging data with the desired PCP device
- Configuration registers for selecting the invoke ID, index, and subindex of the PCP device

The bus coupler supports 16 PCP devices. 16 communication registers and 24 configuration registers are supported.

Example: To read object 5FE0_{hex} of an IB IL RS 232-PAC with communication reference 4, first set the configuration registers (6041 - 6043) to the desired values with the (e. g., 6041 Index: 5FE0_{hex}, 6042 Subindex: 0_{hex}, 6043 Invoke ID: 0_{hex}) with the fc16 command.

Then you can use the fc3 command to read 29 words via communication register 6040.

A Modbus function is only ever used for read/write access to a PCP index. For example, the fc3 command cannot be used to read 20 words from registers 6020 to 6039.

The communication register contains a different value range due to the selected values of the register and the terminal used.

Therefore, for example, the IB IL RS 232-PAC terminal has three different PCP objects. Two objects are one word long, but the third is 29 words long. You can read or write the three configuration registers with a single Modbus command.

An attempt to access a reserved register generates an exception response.

Communi- cation refer- ence	Communi- cation reg- ister	Configura- tion register	Note
CR 2	6020	6021	Index
		6022	Subindex
		6023	Invoke ID
		6024 ... 6029	Reserved
CR 3	6030	6031	Index
		6032	Subindex
		6033	Invoke ID
		6034 ... 6049	Reserved
CR 4	6040	6041	Index
		6042	Subindex
		6043	Invoke ID
		6044 ... 6049	Reserved
...
CR 16	6160	6161	Index
		6162	Subindex
		6163	Invoke ID
		6164 ... 6169	Reserved
CR 17	6170	6171	Index
		6172	Subindex
		6173	Invoke ID
		6174 ... 6179	Reserved

14.18 Transmitting an odd number of data bytes via PCP (firmware version 1.30 or later)

The Modbus functions allow you to exchange data words with PCP devices.

Using bus couplers with firmware version <1.30, it was not possible to access communication objects with a length value that is odd.

Firmware version 1.30 includes the "Ignore last byte" option. This option enables transmission of communication objects that have a length value that is odd.

To transmit an odd number of PCP bytes, set bit 0 in the high byte of the "Invoke ID" PCP configuration register. This leads to the fact that the low byte of the last Modbus data word written or to be read is excluded from PCP transmission.



The PCP invoke ID is an 8-bit datum, thus allowing the high byte of the Modbus register to be used for this function.

This change is backward-compatible, since older firmware versions do not evaluate the bit.

Example 1: Writing 15 data bytes to the 5FE0_{hex} object of the PCP device with communication reference 2 (CR 2)

Initialize the configuration register of CR 2:

Modbus register	Register name	Value (hex)
6021	CR 2 index	5FE0
6022	CR 2 subindex	0
6023	CR 2 invoke ID	100

Eight data words are then written to the CR 2 communication register (register 6020).

The low byte of the last data word written to register 6020 is ignored and is not transmitted to the PCP device.

Example 2: Reading 11 data bytes from the 5FE0_{hex} object of the PCP device with communication reference 4 (CR 4)

Initialize the configuration register of CR 4:

Modbus register	Register name	Value (hex)
6041	CR 4 index	5FE0
6042	CR 4 subindex	0
6043	CR 4 invoke ID	100

Six data words are then read from the CR 4 communication register (register 6040).

The last data byte read by the PCP device is transmitted in the high byte of the last Modbus data word. The low byte is reserved.

15 DDI: Device Driver Interface

The bus coupler supports access via the Device Driver Interface (DDI).



We recommend using the current HFI in new applications.

Using this interface requires the appropriate driver to be installed on the host. For a detailed description of the services, please refer to the "Driver reference manual for G4-based controller boards using PC bus and Ethernet", see "Ordering data".

The following services are supported:

15.1 Services for remote access to the DDI

- DDI_DevOpenNode ()
- DDI_DevCloseNode ()
- DDI_DTI_ReadData ()
- DDI_DTI_WriteData ()
- DDI_DTI_ReadWriteData ()
- DDI_MXI_SndMessage ()
- DDI_MXI_RcvMessage ()
- GetIBSDiagnostic ()

15.2 Connection and error monitoring

- ETH_SetDTITimeoutCtrl ()
- ETH_ClearDTITimeoutCtrl ()
- ETH_SetNet Fail ()
- ETH_GetNet FailStatus ()
- ETH_ClrNet FailStatus ()
- ETH_SetNet FailMode ()
- ETH_GetNet FailMode ()

15.3 Services for process data monitoring

- ETH_ActivatePDinMonitoring ()
- ETH_DeactivatePDinMonitoring ()

15.4 Firmware services

It does not make sense to use every firmware service in both operating modes (activating or deactivating expert mode). For this reason, the following table indicates the assignment of the services to the operating modes. If you use the services differently than the use specified in the table, the firmware may behave as follows:

1. The service is not permitted in this mode and is rejected with a negative acknowledgment.
2. The service is executed and terminated with a positive acknowledgment. The effect of this service is removed by the firmware.

15.4.1 Supported firmware services that can be used in every operating mode

Code (hex)	Service	Function
0309	Read_Configuration	Reads various entries of the configuration directory Used_Attributes: 0002 _{hex} = Device code
030B	Complete_Read_Configuration	Reads all the device data for a configuration Used_Attributes: 0002 _{hex} = Device code
0315	Read_Device_State	Reads status of local bus devices Device_State_Mask: 0008 _{hex} = Peripheral fault
0316	Get_Error_Info	Request additional error information
032A	Get_Version_Info	Read version information
032B	Get_Diag_Info	Reads local bus counter Diag_Info_Attr: 0004 _{hex} = Global_Count
0351	Read_Value	Read system parameter
0714	Control_Device_Function	Sends control commands to local bus device Device_Function: 0003 _{hex} = Conf_Dev_Err 0004 _{hex} = Conf_Dev_Err_All
0750	Set_Value	Assign new values to system parameters
0760	Confirm_Diagnostics	Update diagnostic display and diagnostic register
0956	Reset_Controller_Board	Resets the controller board

15.4.2 Supported firmware services that are only available in expert mode

Code (hex)	Service	Function
0306	Initiate_Load_Configuration	Loads a configuration frame (extension not supported)
0307	Load_Configuration	Transmits the device data for a configuration Used_Attributes: 0002 _{hex} = Device code
030A	Complete_Load_Configuration	Transmits all the device data for a configuration Used_Attributes: 0002 _{hex} = Device code
0308	Terminate_Load_Configuration	Terminate the transmission of configuration data (only for automatic parameterization)
030C	Delete_Configuration	Deletes a configuration
030E	Control_Parameterization	Start or end the parameterization phase
0701	Start_Data_Transfer	Start data transfer
0710	Create_Configuration	Reads in a connected configuration
0711	Activate_Configuration	Compares the saved and connected configuration
1303	Alarm_Stop	Reset local bus



For additional information about firmware services, please refer to the IBS SYS FW G4 UM E user manual.

15.4.3 System parameters for the Set_Value (0750_{hex}) and Read_Value (0351_{hex}) services

Variable_ID (hex)	System parameter	Length	Value/note	
0104	Diagnostic status register	16-bit word	Read only	
0105	Diagnostic parameter register 1	16-bit word	Read only	
010D	Diagnostic parameter register 2	16-bit word	Read only	
2216	Current PD cycle time	32-bit word	Read only	
2240	Plug and Play mode	32-bit word	0	Activate Plug and Play mode
			1	Deactivate Plug and Play mode
2273	On-board inputs and outputs (firmware version 1.42 or later)	32-bit word	0	Deactivate on-board inputs and outputs
			1	Activate on-board inputs and outputs (default)
2275	Expert mode	32-bit word	0	Activate expert mode
			1	Deactivate expert mode
2277	Fault response mode	32-bit word	See "Setting the required fault response mode"	
2278	Delayed start data transfer (firmware version 1.42 or later)	32-bit word	0	Deactivate delayed startup (default)
			1	Activate delayed startup
2293	Time-out for process data watchdog	32-bit word	See "Process Data Watchdog"	

15.5 PCP communication

15.5.1 Transmission of parameter data

Simple devices exchange process data. However, there are also intelligent devices such as frequency converters and controllers. These exchange not only process data, but also larger quantities of data with the control system. This includes, for example, data that is used in the start-up phase of machines. This type of parameter data rarely changes and is transmitted only when necessary.

The INTERBUS protocol can transmit process data and complex data records (parameter data) simultaneously. The comprehensive parameter data is divided into smaller units, transmitted and then recombined.

In the INTERBUS system, the Peripherals Communication Protocol (PCP) divides the parameter data into individual segments. After transmission it recombines the data. PCP refers to the protocol software. This software provides the necessary services for connection establishment and connection termination, etc.



For detailed information on PCP communication, refer to the IBS SYS PCP G4 UM E user manual.



Please note that a maximum of 16 PCP terminals can be connected to the bus coupler.

15.5.2 Supported PCP commands

You can use the MXI interface of the DDI to send the following PCP commands.

Service	Code (hex)
Initiate_Request	008B
Abort_Request	088D
Read_Request	0081
Write_Request	0082
Information_Report_Request	0885
Status_Request	0083
Identify_Request	0087
Load_Kbl_Par_Loc_Request	0264
Read_Kbl_Loc_Request	0203

15.5.3 Configuration of the PCP PDU size

The standard PDU size for communication with all Inline devices is 64 bytes in the transmit and receive direction.

System couplers such as the ILC 200 UNI-PAC have configurable PDU sizes. If you configure a different size here and want to use the bus coupler to communicate with it, you must also configure the bus coupler to the new values.

You can configure the size using web-based management.

16 HFI: High-Level Language Fieldbus Interface

The bus coupler supports access via the High-level Language Fieldbus Interface (HFI).



The software for the HFI user interface is available in the download area of the article at www.phoenixcontact.net/products under the "Software" item.

You will find the associated documentation under the "Quick start guide" item.



Firmware version 1.42 and later can only be used with the HFI version 3.20.

17 SNMP: Simple Network Management Protocol

The bus coupler supports SNMP v1 and v2c.

Management Information Base (MIB)



The corresponding latest MIBs are available on the Internet at phoenixcontact.net/products.

For the object descriptions, please refer to the ASN1 descriptions for this product.

The password for read access is "public". This password cannot be changed.

By default, the password for write and read access is "private" in the delivery state. This password can be changed at any time.

Changing the password

You can use the private "PxC-AX-Control-MIB" MIB to change the password.

This can be downloaded at phoenixcontact.net/product/2703981. You will find the MIB in the "Miscellaneous" area.

	plDevFWCtrlPasswdSet
OID	1.3.6.1.4.1.4346.11.11.11.2.3.1
Syntax	Octet String (2 ... 24)
Access	Read/write
	For security reasons, the response is always "*****" with read access.
Description	You can assign a new password with a maximum of 12 characters here.
Example	Your new password is to be "factory3". Enter the password twice. Your entry: "factory3factory3" Your password for write access is now: "factory3".
	plDevFWCtrlPasswdSuccess
OID	1.3.6.1.4.1.4346.11.11.11.2.3.2
Syntax	Integer
Access	Read
Description	A message is displayed here informing you whether the last password change was successful.
Result	1: Not known 2: Failed 3: Successful

18 WBM: Web-based management

The device has a web server, which generates the required pages for web-based management and, depending on the requirements of the user, sends them to a standard web browser.

You can use web-based management to access static or dynamic information. Examples of static information include technical data or the MAC address. Examples of dynamic information include IP addresses, status information, local bus structure and diagnostics.

In addition, you can change the configuration. This function is protected by a password.

The default password is "private".



Recommendation: Assign your own password during startup.

Calling web-based management

You can address the device's web server using the IP address if it is configured accordingly. The device's homepage (web page) is accessed by entering the URL `http://<IP address>`.

Example: `http://172.16.113.38`



If you cannot access the WBM pages, check the connection settings in your browser. Deactivate the proxy if set.

19 Firmware update

In order to update the firmware of the bus coupler, provide the bus coupler with a firmware container via a TFTP server or load it onto the bus coupler via FTP. Any FTP client or TFTP server can be used for this, e.g., the Factory Manager.

Initiate the firmware update using web-based management. When carrying out the firmware update, the RDY LED flashes yellow.

20 Process data access via XML

The integrated web server offers the option of accessing the process data of the connected Inline terminals through a web page in XML format.

You can access the web pages using a standard web browser. To call up the XML pages with the process data, enter the address in the following format in the address line of the browser:

`http://<IP address>/procdata.xml`

20.1 XML file structure

The XML file contains different data areas:

IL_STATION

Frame for the entire XML file. The mandatory elements of this frame are `IL_BUS_TERMINAL` and `IL_BUS`.

IL_BUS_TERMINAL

This data area contains information on the entire Inline station (bus coupler and all connected terminals).

This data area includes:

- `TERMINAL_TYPE`
- `NAME`
- `IP_ADDRESS`
- `MODULE_NUMBER`
- `DIAGNOSTIC_STATUS_REGISTER`
- `DIAGNOSTIC_PARAMETER_REGISTER`

TERMINAL_TYPE

This area contains the designation of the bus coupler.

NAME

Contains the user-specific station name. You can change the station name via the WBM.

IP_ADDRESS

Contains the IP address of the station.

MODULE_NUMBER

Contains the number of connected Inline terminals, including local I/Os. In the event of a bus error, the number of the last known operable configuration is indicated.

DIAGNOSTIC_STATUS_REGISTER

Contains the local bus status, represented by all bits of the diagnostic status register. A detailed description can be found in the diagnostic parameter register. Whenever an error bit is set, the diagnostic parameter register is rewritten.

IL_BUS

Frame for the connected Inline terminals.

IL_MODULE

Frame for the data of an individual Inline terminal. The terminals are numbered consecutively from one to a maximum of 63.

MODULE_TYPE

Contains the terminal type. Possible types are DI, DO, DIO, AI, AO, AIO and PCP.

PD_CHANNELS

Number of process data channels of an Inline terminal. For digital terminals, the number of channels is equal to the number of supported bits. For other terminals, the number of process data words is indicated.

Example: An IB IL AO 2 has two process data channels and an IB IL 24 DO 8 has eight bits and eight process data channels.

PD_WORDS

Number of process data words in an Inline terminal. Please note that analog terminals always have the same number of output and input words.

Therefore an IB IL AO 2-PAC also has two input channels and an IB IL AI 2-PAC also has two output channels.

PD_IN

This area is used by all terminals that assign input data. The number of process data words depends on the terminal type.

PD_OUT

This area is used by all terminals with output data. The use of bits is identical to their use in PD_IN.

In the event of an error in the Inline station, this is indicated in the diagnostic registers. The D LED on the bus coupler flashes.

The process data is invalid because only internal values are indicated, not the values on the local bus.

To ensure that valid data is displayed, the diagnostic register must also always be queried.

The same is true in the event of a faulty configuration. In this

case, the local bus does not run and only internal values can be read in the XML file.

In the event of a peripheral fault, all data is valid, except for the data of the faulty terminal.

Examples

a) Inline terminal with two active inputs.

```
<IL_MODULE number="1">
<MODULE_TYPE>DI</MODULE_TYPE>
<PD_CHANNELS>2</PD_CHANNELS>
<PD_WORDS>1</PD_WORDS>
<PD_IN word="1">3</PD_IN>
</IL_MODULE>
```

b) Inline terminal with two digital inputs and only the second input is active.

```
<IL_MODULE number="3">
<MODULE_TYPE>DI</MODULE_TYPE>
<PD_CHANNELS>2</PD_CHANNELS>
<PD_WORDS>1</PD_WORDS>
<PD_IN word="1">2</PD_IN>
</IL_MODULE>
```

c) Inline terminal with 16 digital inputs and inputs 13 and 14 are active.

```
<IL_MODULE number="7">
<MODULE_TYPE>DI</MODULE_TYPE>
<PD_CHANNELS>16</PD_CHANNELS>
<PD_WORDS>1</PD_WORDS>
<PD_IN word="1">12288</PD_IN>
</IL_MODULE>
```

The input word returns the value 12288 ($2^{12} + 2^{13}$).

d) Inline terminal with two analog inputs, of which only the first channel is active (14970).

```
<IL_MODULE number="10">
<MODULE_TYPE>AI</MODULE_TYPE>
<PD_CHANNELS>2</PD_CHANNELS>
<PD_WORDS>2</PD_WORDS>
<PD_IN word="1">14970</PD_IN>
<PD_IN word="2">8</PD_IN>
<PD_OUT word="1">0</PD_OUT>
<PD_OUT word="2">0</PD_OUT>
</IL_MODULE>
```