

PLC-5 Programmable Controllers Comparison

Category	Controller	Catalog Number	User Memory Words, Max	Total I/O, Max	Number of Communication Ports (mode)
Standard	PLC-5/11	1785-L11B	8000	512	1 DH+ or Remote I/O (Adapter or Scan)
	PLC-5/20	1785-L20B	16,000	512	1 DH+ and 1 DH+ or Remote I/O (Adapter or Scan)
	PLC-5/30	1785-L30B	32,000	1024	2 DH+ or Remote I/O (Adapter or Scan)
	PLC-5/40	1785-L40B	48,000	2048	4 DH+ or Remote I/O (Adapter or Scan)
	PLC-5/40L	1785-L40L	48,000	2048	2 DH+ or Remote I/O (Adapter or Scan) and 1 Extended Local I/O
	PLC-5/60	1785-L60B	64,000	3072	4 DH+ or Remote I/O (Adapter or Scan)
	PLC-5/60L	1785-L60L	64,000	3072	2 DH+ or Remote I/O (Adapter or Scan) and 1 Extended Local I/O
	PLC-5/80	1785-L80B	100,000	3072	4 DH+ or Remote I/O (Adapter or Scan)
Standard with Protected Memory	PLC-5/26	1785-L26B	16,000	512	1 DH+ and 1 DH+ or Remote I/O (Adapter or Scan)
	PLC-5/46	1785-L46B	48,000	2048	4 DH+ or Remote I/O (Adapter or Scan)
	PLC-5/86	1785-L86B	100,000	3072	4 DH+ or Remote I/O (Adapter or Scan)
ControlNet	PLC-5/20C	1785-L20C15	16,000	512	1 ControlNet (Dual Media) and 1 DH+
	PLC-5/40C	1785-L40C15	48,000	2048	1 ControlNet (Dual Media) and 2 DH+ or Remote I/O (Adapter or Scan)
	PLC-5/80C	1785-L80C15	100,000	3072	1 ControlNet (Dual Media) and 2 DH+ or Remote I/O (Adapter or Scan)
ControlNet with Protected Memory	PLC-5/46C	1785-L46C15	48,000	2048	1 ControlNet (Dual Media) and 2 DH+ or Remote I/O (Adapter or Scan)
Ethernet	PLC-5/20E	1785-L20E	16,000	512	1 Ethernet, 1 DH+ and 1 DH+ or Remote I/O (Adapter or Scan)
	PLC-5/40E	1785-L40E	48,000	2048	1 Ethernet, 2 DH+ or Remote I/O (Adapter or Scan)
	PLC-5/80E	1785-L80E	100,000	3072	1 Ethernet, 2 DH+ or Remote I/O (Adapter or Scan)

Introduction

1785 PLC-5 Programmable Controller: The Foundation of Control Architecture

The PLC-5 programmable controller stands at the center of a control architecture that brings together existing and future systems by means of networks such as EtherNet/IP, ControlNet and DeviceNet, and offers connectivity among SLC 500, ControlLogix, and MicroLogix controllers. Because they include embedded network connections, PLC-5 controllers enable your control architecture to be flexible enough to include cost-effective connections to a wide range of devices.



Controllers

Information, Control, and Device Communication Capability

I/O Modules

Many Choices to Meet Your Exact Requirements

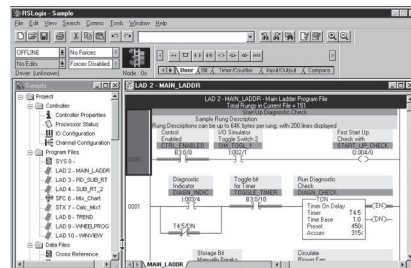
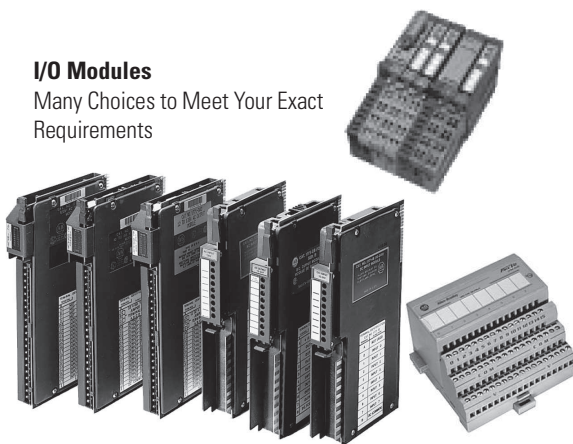

Software Tools

Program in Structured Text, Function Block, Sequential Function Charts or Ladder Logic Languages

Topic	Page
PLC-5 System Overview	2
Lay Out the System	4
Select I/O Modules	7
Select Network Communications	19
Select Controllers	31
Select Chassis	37
Select Power Supplies	39
Select Software	43
ViewAnyWare Products	50
Summary	53

PLC-5 System Overview

A PLC-5/1771 control system, at minimum, consists of a programmable controller and I/O modules in a single 1771 chassis with a power supply. You choose the controller with the on-board communication ports you need.

A simple system can consist of only a standalone controller and I/O modules all in a single chassis

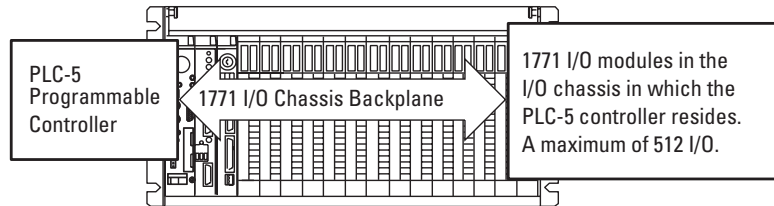

On-board remote I/O scanner ports are available on all PLC-5 controllers. On-board extended-local I/O scanner ports are available on some PLC-5 controllers. On-board ControlNet ports are available on some PLC-5 controllers. To provide a DeviceNet I/O scanner port to the system, you must add a 1771-SDN DeviceNet Scanner Module.

In the typical configuration illustration, a ControlNet port on the controller interfaces the processor to the ControlNet link. In each of the two chassis remote from the controller, a 1771-ACN15 I/O Adapter Module provides I/O modules in those chassis with an interface to the ControlNet link. In this configuration, the PLC-5 controller monitors/controls the I/O in its local I/O chassis as well as the I/O in the remote locations.

Multiple controllers can communicate across networks; and I/O in multiple platforms can be distributed in many locations connected over multiple I/O links

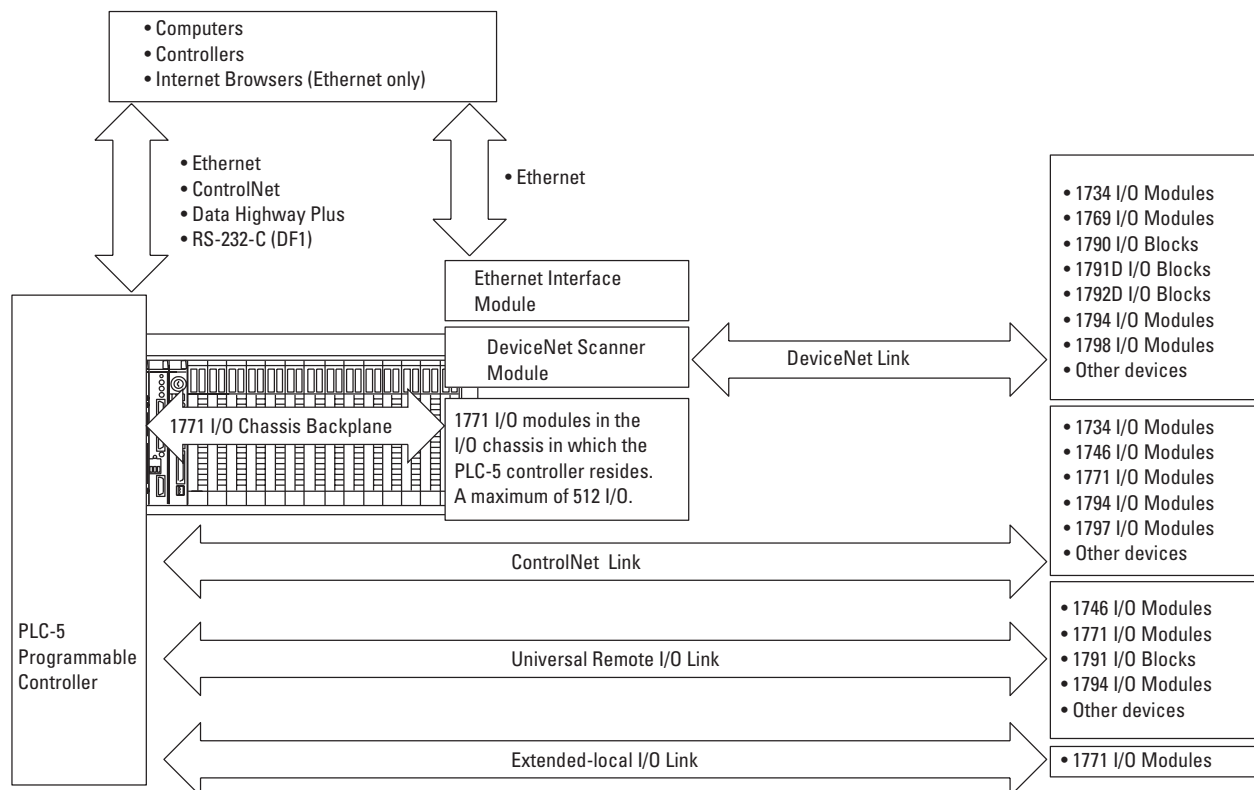

Plug a 1771 power supply module into an I/O module slot, or connect a standalone 1771 power supply into the left end of each chassis.

Depending on the communication ports available on your particular PLC control system, you can select operator interfaces that are compatible with those particular ports.

Lay Out the System

Lay out the system by determining the network configuration and the placement of components in each location. Decide at this time whether each location will have its own controller.

Place each controller's I/O on an isolated network to maximize the performance and to more easily accommodate future network or system configuration changes. If you plan to share I/O, make sure the I/O is on a network that each controller can access.

Assume that Network A and Network B both require a controller and its I/O. Both controllers interact with time-critical information.

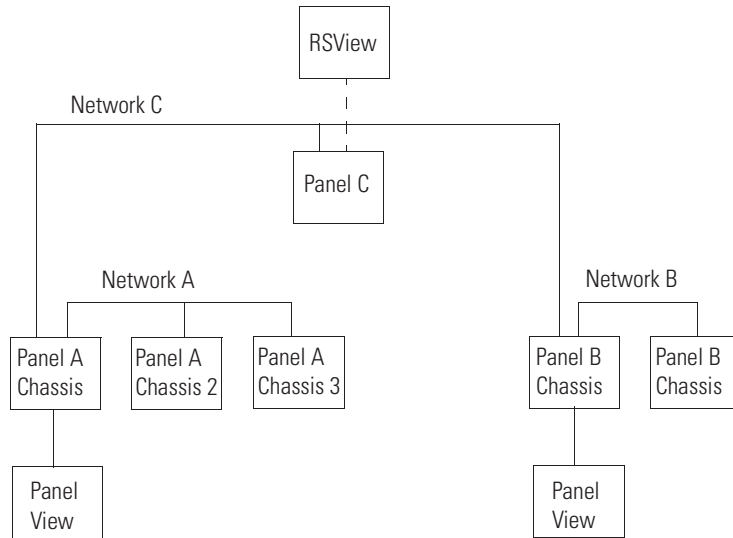

For a PLC-5 controller to control I/O modules, both the controller and the I/O modules must be directly attached to the same network.

I/O Location	Controller in Panel A, Chassis 1	Controller in Panel B, Chassis 1
Panel A, chassis 1	Yes	Yes
Panel A, chassis 2	Yes	No
Panel A, chassis 3	Yes	No
Panel B, chassis 1	Yes	Yes
Panel B, chassis 2	No	Yes
Panel C, chassis 1	Yes	Yes

Evaluate what communications need to occur between controllers. If there is sporadic information that is not time-critical, use a message-based network such as an EtherNet/IP (the information portion), Data Highway Plus, or the unscheduled portion of the ControlNet network. If the information is time-critical, such as producer/consumer tags between controllers, use the ControlNet or EtherNet/IP network.

Select a Network

Configure your system for information exchange between a range of devices and computing platforms and operating systems.

If your application requires	Use this network	Select
<ul style="list-style-type: none"> High-speed data transfer between information systems and/or a large quantity of controllers Internet/intranet connection Program maintenance 	EtherNet/IP	<ul style="list-style-type: none"> 1785-L20E controller 1785-L40E controller 1785-L80E controller Applicable PLC-5 controller with 1785-ENET interface module
<ul style="list-style-type: none"> High-speed transfer of time-critical data between controllers and I/O devices Deterministic and repeatable data delivery Program maintenance Media redundancy or intrinsic safety options 	ControlNet	<ul style="list-style-type: none"> 1785-L20C15 1785-L40C15 1785-L80C15
<ul style="list-style-type: none"> Connections of low-level devices directly to plant floor controllers, without the need to interface them through I/O modules More diagnostics for improved data collection and fault detection Less wiring and reduced start-up time than a traditional, hard-wired system 	DeviceNet	PLC-5 controller with 1771-SDN scanner module
<ul style="list-style-type: none"> Plant-wide and cell-level data sharing with program maintenance 	Data Highway Plus	All PLC-5 controllers have at least one built-in, configurable Data Highway Plus channel
<ul style="list-style-type: none"> Connections between controllers and I/O adapters Distributed controllers so that each controller has its own I/O and communicates with a supervisory controller 	Remote I/O	All PLC-5 controllers have at least one built-in, configurable remote I/O channel
<ul style="list-style-type: none"> Modems Messages that send and receive ASCII characters to or from devices such as ASCII terminals, bar-code readers, message displays, weigh scales, or printers Supervisory control and data acquisition (SCADA) 	Serial Network	All PLC-5 controllers have one built-in serial port configurable for RS-232, RS-423, or RS-422A

ControlNet Network



ControlNet PLC-5 controllers offer embedded ControlNet communication capabilities for control and information processing. The ControlNet network provides both I/O control and peer-to-peer communications on a 5 Mbps network, with repeatability and determinism.

You can have multiple ControlNet PLC-5 controllers on one ControlNet network, with each controller handling its own I/O on the network, and at the same time communicating with each other. Multiple controllers can receive input data from one I/O or device node.

ControlNet PLC-5 Programmable Controllers

Cat. No.	User Memory (words), Max	Total I/O Max	Channels	Number of I/O Chassis, Max			ControlNet I/O Map Entries	Cable	Power Dissipation, Max	Backplane Current Load
				Total	Extended -local	Remote				
1785-L20C15	16,000	512 any mix or 512 in + 512 out (complement)	1 ControlNet 1 DH+ 1 DH+/remote I/O	77	0	12	64	1786-CP	15.8 W	3.0 A
1785-L40C15	48,000	2048 any mix or 2048 in + 2048 out (complement)	1 ControlNet 2 DH+/remote I/O	125	0	60	96	1786-CP	15.8 W	3.0 A
1785-L46C15 Protected	48,000	2048 any mix or 2048 in + 2048 out (complement)	1 ControlNet 2 DH+/remote I/O	125	0	60	96	1786-CP	15.8 W	3.0 A
1785-L80C15	100,000	3072 any mix or 3072 in + 3072 out (complement)	1 ControlNet 2 DH+/remote I/O	125	0	92	128	1786-CP	15.8 W	3.0 A

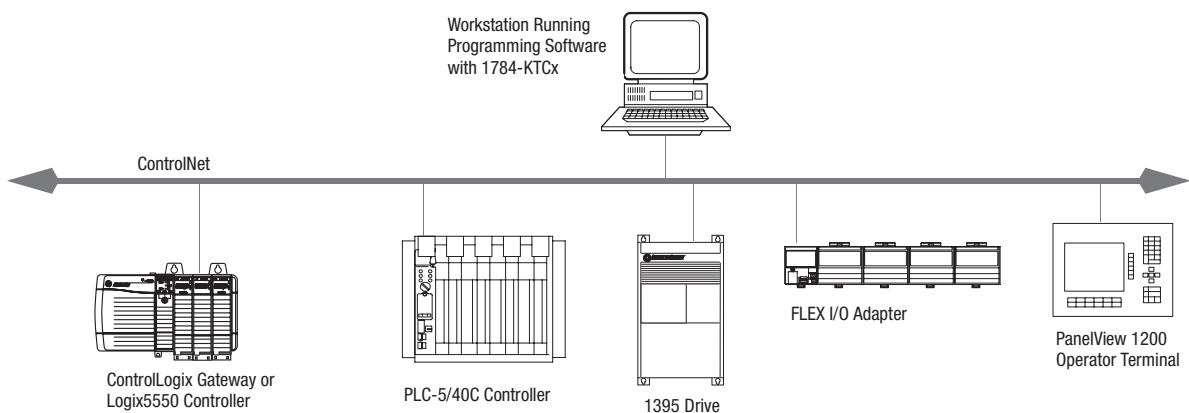

ControlNet Communication Adapters

Cat. No.	Function	Comm. Rate	Design Considerations	Cable	Power Dissipation, Max	Backplane Current Load
1734-ACNR	Interfaces POINT I/O modules in a POINTBus backplane to ControlNet controllers across a ControlNet network	5 Mbps	Requires a remote ControlNet PLC-5 controller, Series F, Revision E, or later.	Quad shield RG-6 coaxial cable	5.0 W	1.0 A
1747-ACN15, -ACNR15	Interfaces SLC I/O modules in an SLC chassis to a ControlNet scanner port across a ControlNet network	5 Mbps	Requires a remote ControlNet PLC-5 controller.	Quad shield RG-6 coaxial cable	5 W	900 mA
1771-ACN15, -ACNR15	Interfaces 1771 I/O modules in a 1771 chassis to a ControlNet scanner port across a ControlNet network	5 Mbps	Place in remote ControlNet chassis. Requires a ControlNet PLC-5 controller.	Quad shield RG-6 coaxial cable	5.2 W	1.0 A
1794-ACN15, -ACNR15	Interfaces FLEX I/O modules in a FLEX I/O rack to a ControlNet scanner port across a ControlNet network	5 Mbps	Requires a remote ControlNet PLC-5 controller.	Quad shield RG-6 coaxial cable	4.6 W	640 mA
1797- -ACNR15	Interfaces FLEX Ex I/O modules in a FLEX Ex rack to a ControlNet scanner port across a ControlNet network	5 Mbps	Requires a remote ControlNet PLC-5 controller.	Quad shield RG-6 coaxial cable	8.5 W	640 mA

ControlNet Hot Backup Module

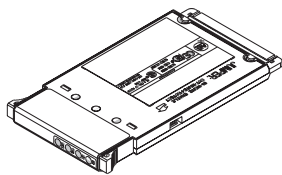

The ControlNet Hot Backup Module provides backup of ControlNet I/O. A secondary controller qualifies critical control information with the primary controller. Both controllers consume information from inputs and connect to outputs, but only the primary controller controls the outputs. The secondary controller establishes control of outputs if the primary controller shuts down.

ControlNet Hot Backup Basic System

Cat. No.	Quantity	Description
1785-CHBM	2	ControlNet Hot Backup Modules
1785-L40C15/F or 1785-L80C15/F ⁽¹⁾	2	ControlNet PLC-5 Programmable Controllers, Series F or later
1771-A1B through 1771-A4B	2	1771 I/O Chassis
1771-P4 through 1771-P10	2	1771 Power Supplies
1771-ACN(R)15, 1747-ACN(R), or 1794-ACN(R)	1	ControlNet Adapter
1784-KTCX15 or 1784-PCC card	1	Communication card for personal computer or laptop computer
9234 Series	1	RSLogix 5 Programming Software, version 3.22 or later
9357-CNETL3	1	RSNetWorx for ControlNet Software, version 1.80.xx or later
9234 Series	1	RSLink Gateway Communication Software, version 2.00.97.30 or later
Other System Requirements	ControlNet network cables, taps, and terminators for connections between the PLC-5 controllers and I/O adapters	

⁽¹⁾Both controllers must have the same series and firmware revision.

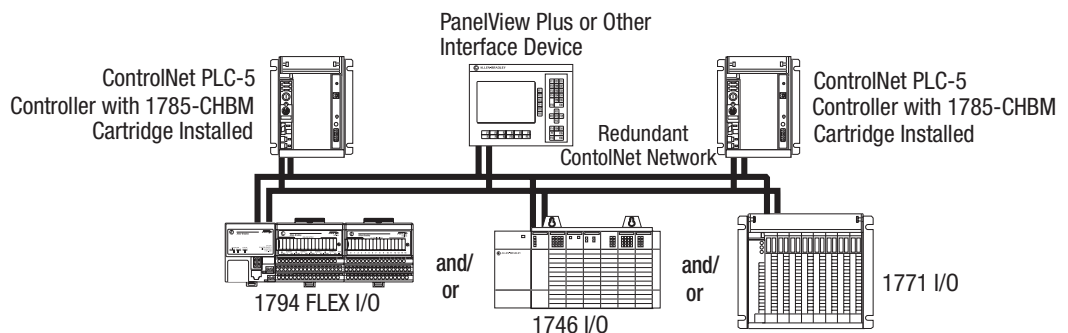

Data Highway Plus

The Data Highway Plus (DH+) network is a local area network designed to support remote programming and data acquisition for factory-floor applications. You can also use DH+ communication modules to implement a small peer-to-peer network.

You can use a DH+ network for data transfer to other PLC-5 controllers or high-level computers and as a link for programming multiple PLC-5 controllers. A PLC-5 controller can communicate over a DH+ network with other controllers and with a workstation.

The DH+ network supports daisy-chain and trunkline-dropline configurations.

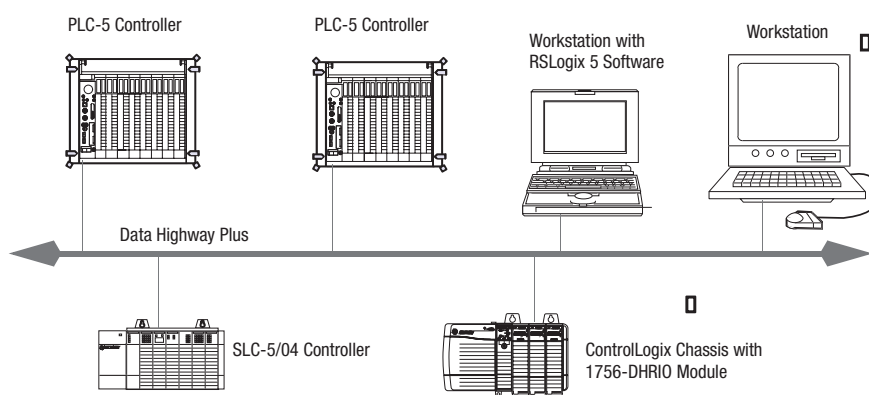

Cat. No.	Function	Comm. Rate	Connections	Design Considerations	Cable	Power Dissipation, Max	Backplane Current Load
1785-KA	Provides an interface between Data Highway Plus and Data Highway-485 link	<ul style="list-style-type: none"> DH+ 57 Kbps DH-485 configurable 	DH+ DH-485	Place in the local chassis	<ul style="list-style-type: none"> Data Highway 1770-CD RS-232 1770-CG or Modem Interface Cable 1770-CP 	10.5 W	2.0 A
1785-KE	Provides an interface between Data Highway Plus and RS-232-C link	<ul style="list-style-type: none"> DH+ 57 Kbps RS-232-C configurable 	DH+ RS-232-C	Place in the local chassis	<ul style="list-style-type: none"> Data Highway 1770-CD RS-232 1770-CG or Modem Interface Cable 1770-CP 	6.3 W	1.2 A

Remote I/O

The strength and versatility of the remote I/O network comes from the breadth of products it supports. In addition to 1771 I/O, the remote I/O network supports many Rockwell Automation and third-party devices.

Typical applications range from simple I/O links with controllers and I/O, to links with a variety of other devices. You connect devices through remote I/O adapter modules or built-in remote I/O adapters.

Using the remote I/O network instead of direct-wiring a device over a long distance to a local I/O chassis helps reduce installation, startup, and maintenance costs by placing the I/O closer to the sensors and actuators.

Some devices, like PLC-5 support Pass-Through, let you configure devices on a remote I/O network from an Ethernet, ControlNet, or Data Highway Plus network.

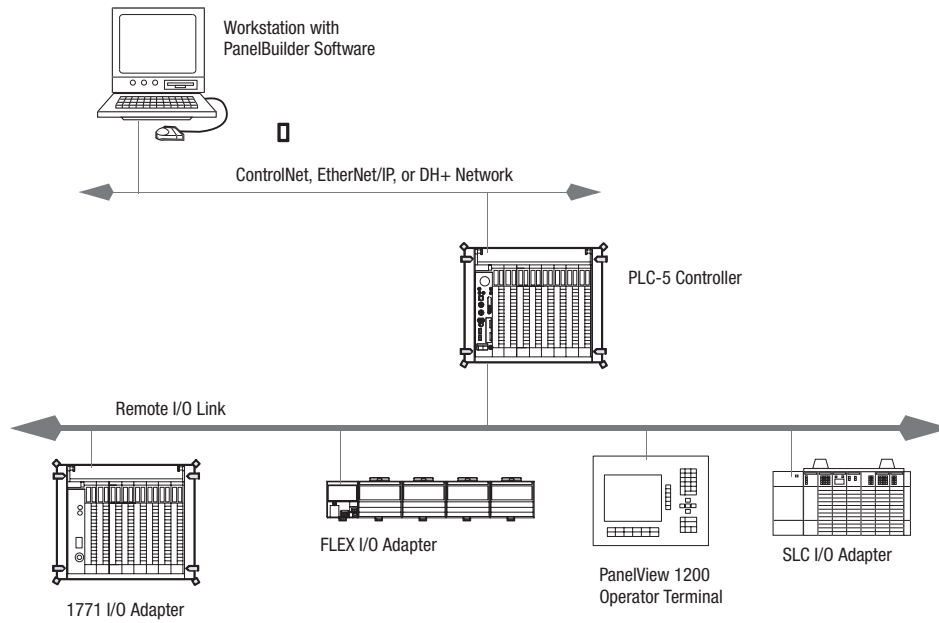

Cat. No.	Function	Comm. Rate	Connections	Design Considerations	Cable	Power Dissipation, Max	Backplane Current Load
1771-ASB	Interfaces I/O modules in an I/O chassis to a remote scanner port across a remote I/O link	57.6 Kbps 115 Kbps 230 Kbps	Remote I/O adapter port	Place in a remote chassis. Requires a PLC-5 controller that supports remote I/O	1770-CD Belden 9463	5.2 W	1.0 A
1771-DCM	Provides a remote I/O adapter port for a local PLC-5 controller to communicate with a remote I/O scanner port of a supervisory process across a remote I/O link	57.6 Kbps 115.2 Kbps	Remote I/O adapter port	Place in the local chassis	1770-CD Belden 9463	6.3 W	1.2 A

Enhanced PLC-5 Controllers



Every PLC-5 controller offers built-in, configurable ports for Data Highway Plus (DH+) or Remote I/O. A DH+ connection supports remote programming and information access, in addition to peer-to-peer communication between the PLC-5, other controllers, and devices. A Remote I/O connection supports real-time data exchange for I/O, operator interface, and other third-party devices.

Cat. No.	User Memory (words), Max	Total I/O, Max	Channels	Number of I/O Chassis, Max				Power Dissipation, Max	Backplane Current Load
				Total	Extended -local	Remote	ControlNet		
1785-L11B	8000	512 any mix or 384 in + 384 out (complement)	1 DH+/remote I/O	5	0	4	0	12 W	2.3 A
1785-L20B	16,000	512 any mix or 512 in + 512 out (complement)	1 DH+ 1 DH+/remote I/O	13	0	12	0	12 W	2.3 A
1785-L30B	32,000	1024 any mix or 1024 in + 1024 out (complement)	2 DH+/remote I/O	29	0	28	0	12 W	2.3 A
1785-L40B	48,000	2048 any mix or 2048 in + 2048 out (complement)	4 DH+/remote I/O	61	0	32 max/link	0	17.3 W	3.3 A
1785-L60B	64,000	3072 any mix or 3072 in + 3072 out (complement)	4 DH+/remote I/O	93	0	32 max/link	0	17.3 W	3.3 A
1785-L80B	100,000	3072 any mix or 3072 in + 3072 out (complement)	4 DH+/remote I/O	93	0	32 max/link	0	17.3 W	3.3 A

Back Up Controller Memory

You can back up program files using an EEPROM module.

Cat. No.	Provides this amount of backup memory
1785-ME16 ⁽¹⁾	16,000 words
1785-ME32	32,000 words
1785-ME64	64,000 words
1785-CHBM	100,000 words

⁽¹⁾Not for use with ControlNet PLC-5 controllers.

Battery Replacement and Life Estimates

Cat. No.	Applies to	When used in this controller	At this temperature	Battery Life Estimate	
				Power off 100%	Power off 50%
1770-XYC	All PLC-5 Programmable Controllers	PLC-5/11, -5/20 and -5/20E	60 °C (140 °F)	256 days	1.4 years
			25 °C (77 °F)	2 years	4 years
		All Others	60 °C (140 °F)	84 days	150 days
			25 °C (77 °F)	1 year	1.2 years

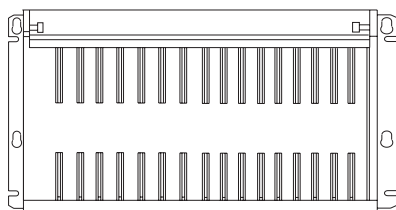

Select Chassis

Step 4 - Select Chassis:

- With the number of slots you need
- That meet your power supply requirements
- That meet your panel size and space limitations

The PLC-5 programmable controller requires a 1771 chassis to contain the various modules. Chassis are available in sizes of 1, 2, 4, 8, 12, and 16 module slots.

The backplane provides a communication path between the I/O modules and either the controller or the I/O adapter module.

The consistent size and mounting of the available 1771 chassis provide a universal configuration for system design and chassis-mounting configurations. If you anticipate that your system will expand, you may want to purchase a larger chassis for future expansion.

Cat. No.	Description	No. I/O Slots	Dimensions, Approx. (HxWxD)	Weight, Approx., kg (lb)	Mounting Type
1771-A1B	I/O chassis for 1771 I/O modules	4 slots	315 x 229 x 193 mm (12.4 x 9.0 x 7.6 in.)	3.6 (8.0)	Back-panel
1771-A2B	I/O chassis for 1771 I/O modules	8 slots	315 x 356 x 193 mm (12.4 x 14.0 x 7.6 in.)	4.7 (10.3)	Back-panel
1771-A3B	I/O chassis for 1771 I/O modules	12 slots	339 x 484 x 217 mm (13.5 x 19.0 x 8.5 in.)	3.6 (8.0)	19-in. rack or back-panel
1771-A3B1	I/O chassis for 1771 I/O modules	12 slots	315 x 483 x 193 mm (12.4 x 19.0 x 7.6 in.)	5.7 (12.6)	Back-panel
1771-A4B	I/O chassis for 1771 I/O modules	16 slots	315 x 610 x 193 mm (12.4 x 24.0 x 7.6 in.)	6.7 (14.8)	Back-panel
1771-PSC	Power-supply chassis (for connecting power directly or through a cable to an I/O chassis). Slots for installation of power supplies and modules requiring only power from the backplane.	4 slots	311 x 203 x 180 mm (12.2 x 8.0 x 7.1 in.)	1.9 (4.1)	Back-panel
1771-AM1	I/O chassis with integral remote I/O adapter and power supply (3 A available for I/O modules)	1 slot	298 x 70 x 187 mm (11.7 x 2.7 x 7.3 in.)	1.4 (3.0)	Back-panel
1771-AM2	I/O chassis with integral remote I/O adapter and power supply (3 A available for I/O modules)	1 slot	298 x 130 x 187 mm (11.7 x 5.1 x 7.3 in.)	2.3 (5.0)	Back-panel

Mounting Dimensions

Minimum Spacing Requirements for a Controller-resident Chassis

- Mount the I/O chassis horizontally.
- Allow 153 mm (6 in.) above and below the chassis.
- Allow 102 mm (4 in.) on the sides of each chassis.
- Allow 51 mm (2 in.) vertically and horizontally between any chassis and the wiring duct or terminal strips.
- Leave any excess space at the top of the enclosure, where the temperature is the highest.

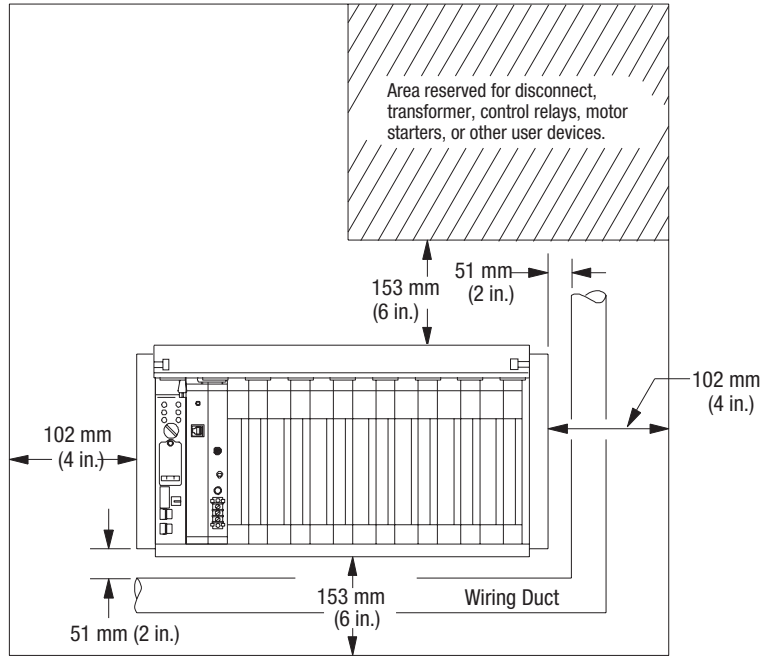

Minimum Spacing Requirements for a Remote I/O and Extended-local I/O Chassis

- Mount the I/O chassis horizontally.
- Allow 153 mm (6 in.) above and below all chassis. When you use more than one chassis in the same area, allow 152.4 mm (6 in.) between each chassis.
- Allow 102 mm (4 in.) on the sides of each chassis. When you use more than one chassis in the same area, allow 101.6 mm (4 in.) between each chassis.
- Allow 51 mm (2 in.) vertically and horizontally between any chassis and the wiring duct or terminal strips.
- Leave any excess space at the top of the enclosure, where the temperature is the highest.

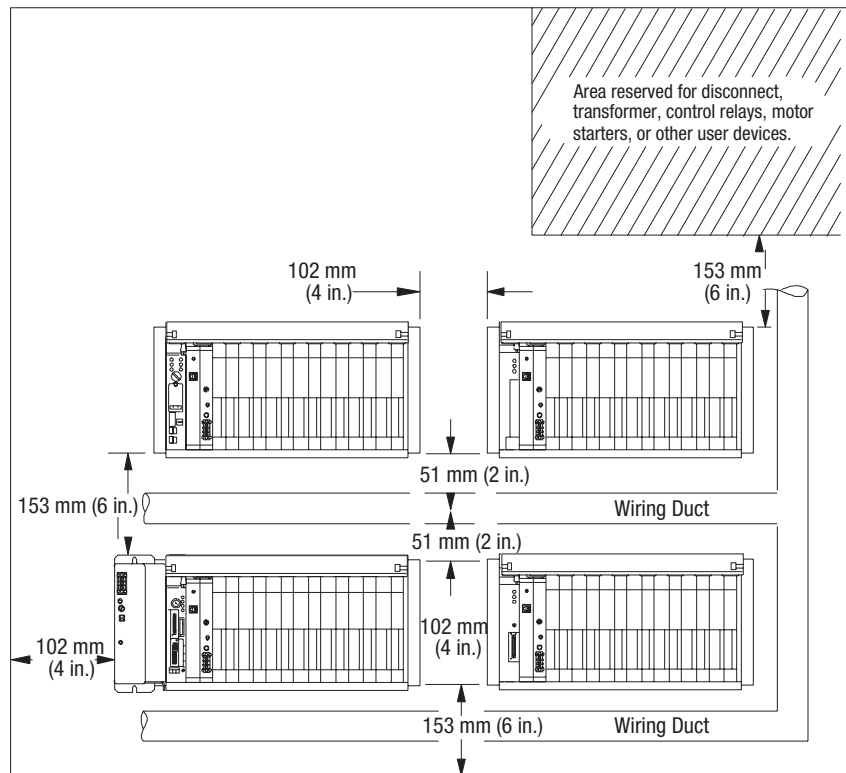

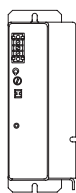
**Step 5 - Select:**

- One power supply for each chassis

Select Power Supplies

The 1771 power supplies provide 5V dc power directly to the chassis backplane. These power supplies occupy one or two slots in a 1771 chassis and can provide up to 8 A per supply to the I/O chassis.

These power supplies require no space outside the chassis, except for the 1771-P7P power supply. The 1771 power supplies connect directly to the chassis backplane and can be paralleled to provide greater current. Redundancy is available for greater availability.

Cat. No.	Input Voltage, Nom	Input Voltage Range	Real Input Power, Max	Apparent Input Power, Max	Transformer Load, Max	User Output Current	Backplane Output Current	Frequency	Location, No. of Slots
1770-P1	120V ac or 220/240V ac	105-125V ac 205-250V ac	20 W	37V A	50V A	300 mA @ +5V dc +150 mA @ +15Vdc -150 mA @ 15V dc	N/A	50...440 Hz	Standalone
1771-P4S	120V ac	97-132V ac	59 W	89V A	148V A	none	8 A @ +5V dc	47...63 Hz	1771 Chassis, 1 slot
1771-P5	24V dc	20.5-30V dc	57 W	N/A	N/A	none	8 A @ +5V dc	dc/Rect sine	1771 Chassis, 2 slots
1771-P5E	24V dc (has selectable power-loss delay)	20.5-30V dc	57 W	N/A	N/A	none	8 A @ +5V dc	dc/Rect sine	1771 Chassis, 2 slots
1771-P4S1	100V ac	85-120V ac	56 W	89V A	140V A	none	8 A @ +5V dc	47...63 Hz	1771 Chassis, 1 slot
1771-P6S1	200V ac	170-240V ac	56 W	89V A	140V A	none	8 A @ +5V dc	47...63 Hz	1771 Chassis, 1 slot
1771-P4R	120V ac	97-132V ac	59 W	92V A	148V A	none	8 A @ +5V dc	47...63 Hz	1771 Chassis, 1 slot
1771-P6R	220V ac	194-264V ac	59 W	92V A	148V A	none	8 A @ +5V dc	47...63 Hz	1771 Chassis, 1 slot
1771-P6S	220V ac	194-264V ac	56 W	89V A	140V A	none	8 A @ +5V dc	47...63 Hz	1771 Chassis, 1 slot
1771-P7	120V ac or 220V ac	97-132V ac 195-264V ac	108 W	176V A	270V A	none	16 A @ +5V dc	47...63 Hz	Standalone
1771-PS7	120V ac or 220V ac	97-132V ac 195-264V ac	171 W	257V A	427V A	8 A @ 5V dc 2 A @ 15V dc 2 A @ -15V dc 2.5 A @ 24V dc	16 A @ +5V dc (total output power including user is 100 W max)	47...63 Hz	Standalone
1771-P10	125V dc	97-145V dc	51 W	N/A	N/A	none	8 A @ +5V dc	dc/Rect sine	1771 chassis, 2 slots

For more information, see the 1771 I/O Chassis and Power Supplies Product Data, publication 1771-2.185.

Power Requirements and Transformer Sizing

Each ac input power supply generates a shutdown signal on the backplane whenever the ac line voltage drops below its lower voltage limit. It removes the shutdown signal when the line voltage comes back up to the lower voltage limit. This shutdown is necessary so that only valid data is stored in memory.

The external transformer rating (V A) of each power supply is greater than its real input power (W) because a capacitor-input ac/dc supply draws power only from the peak of the ac voltage wave form. If the transformer is too small, it clips the peak of the sine wave, when the voltage is still above the lower voltage limit. The power supply will sense this clipped wave form as low voltage and could prematurely shut down modules in the chassis.

The following Power Load and Transformer Sizing graphs display the backplane power load on the vertical axis.

Since these supplies have multiple outputs, the backplane power load is given in watts.

- Use the real power value (W) for determining the amount of heat dissipation you will have inside the enclosure.
- Use the apparent power value (V A) for estimating power distribution sizing.
- Use the transformer load value (V A) of each power supply plus all other loads on a transformer to determine the required transformer size.

Power Load and Transformer Sizing

1771-P4S, -P6S,
-P4S1, -P6S1
ac/dc

Backplane
Current Load
(A)

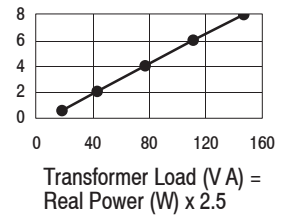
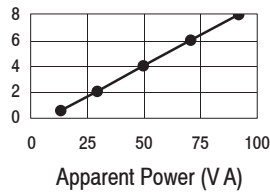
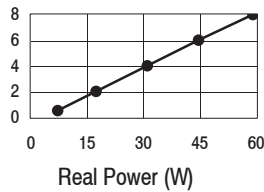

1771-P4R, -P6R
ac/dc
1 Unit

Backplane
Current Load
(A)

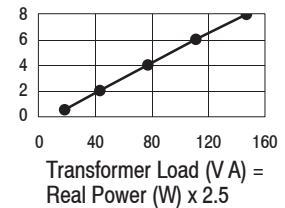
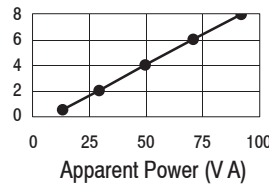
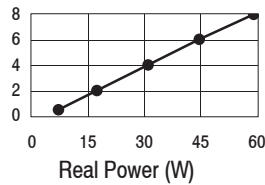

1771-P4R, -P6R
ac/dc
2 Units

Backplane
Current Load
(A)

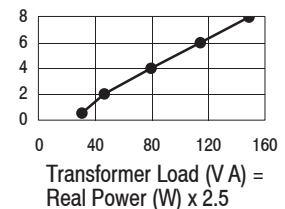
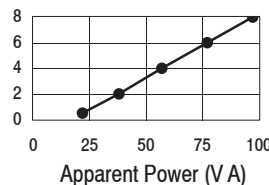
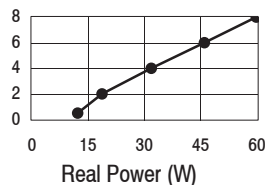

1771-P4R, -P6R
ac/dc
3 Units

Backplane
Current Load
(A)

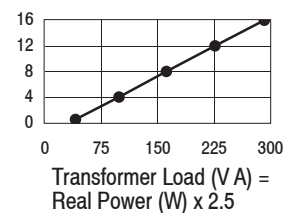
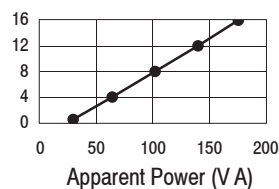
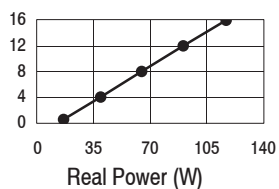

1771-P4R, -P6R
ac/dc
4 Units

Backplane
Current Load
(A)

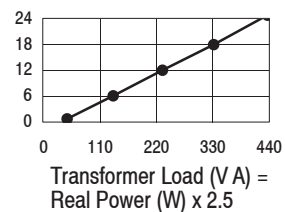
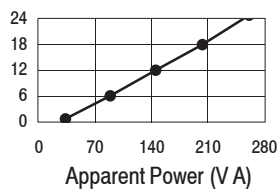
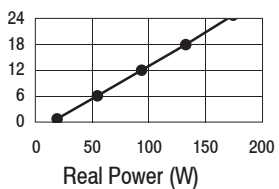

1771-P5, -P5E
dc/dc

Backplane
Current Load
(A)

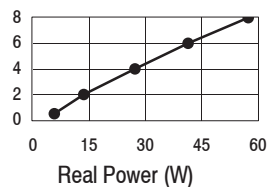

1771-P7
ac/dc

Backplane
Current Load
(A)

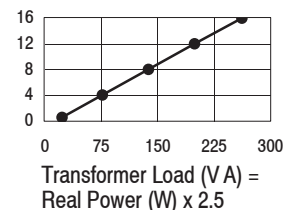
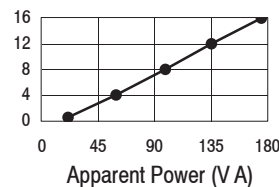
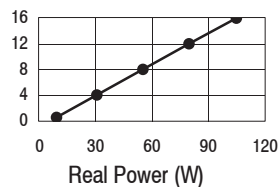

1771-PS7
ac/dc

Backplane
Current Load
(A)

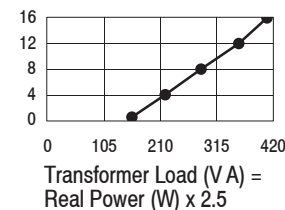
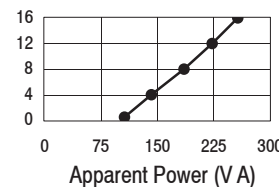
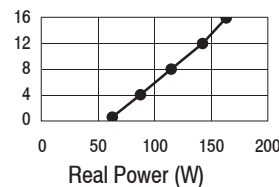

1771-P10
dc/dc

Backplane
Current Load
(A)

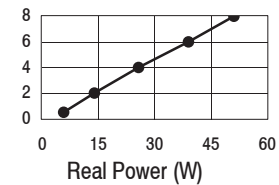

Step 6 - Select:

- RSLogix 5 Programming Software
- RSLinx Software
- RSNetWorx Network Configuration Software
- RSLogix Emulate 5 Emulation Software
- PLC-5 Controller and Training Software
- ViewAnyWare Products

Select Software

Your selection of communication modules and network configuration determines what software packages you need to configure and program your system.

The PLC-5 controllers support multiple industry-standard programming languages. You can program in structured text, function block, sequential function charts, or ladder logic. This versatility means you can maintain and troubleshoot programs in the same language that you develop them.

To use a	You need	Order this cat. no.
PLC-5 Programmable Controller	RSLogix 5 software	9234-RL5300ENE
PLC-5 Programmable Controller on ControlNet	RSLogix 5 software with RSNetWorx for ControlNet software	9234-RWCNTENE (RSLogix 5 software plus RSNetWorx for ControlNet software)
1771-SDN DeviceNet Scanner Module	RSLogix 5 software with RSNetWorx for DeviceNet software	9234-RL5300NXENE (RSLogix 5 software plus RSNetWorx for DeviceNet software)
PLC-5-based system you want to emulate	RSLogix Emulate 5 software	9324-RL350END (RSLogix 5 software plus RSLogix Emulate 5 software)
Operator interface	RSView32 software	ViewAnyWare products (see page 51)
PLC-5 single software solution for all your PLC-5 software needs	RSLogix 5 Professional software with ControlNet, DeviceNet and EtherNet/IP	9324-RL5700NXENE

Programming Software

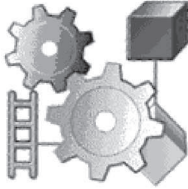

Use RSLogix 5 programming software to configure 1771 I/O and communication modules and to program the PLC-5 programmable controller. RSLogix 5 software offers relay ladder, structured text, function block diagram, and sequential function chart editors for you to develop application programs.

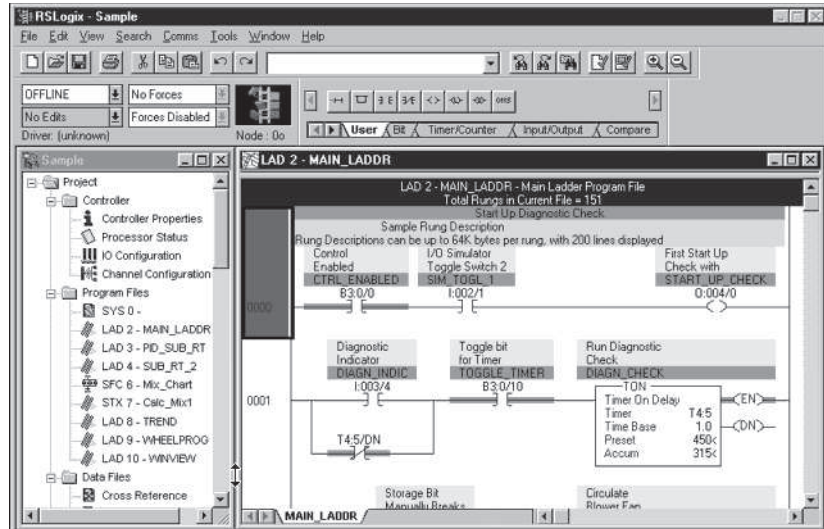

RSLogix 5 Software Requirements

Description	Min	Recommended
Personal computer	Intel Pentium II or greater	Intel Pentium III 700 MHz
Software requirements	Supported: <ul style="list-style-type: none"> • Microsoft Windows XP • Microsoft Windows 2000 • Microsoft Windows ME 	
RAM	128 MB	256 MB
Hard disk space	70 MB (or more, based on application requirements)	
Video requirements	256-color VGA graphics adapter, 800 x 600 resolution	True Color 1024 x 768 resolution

RSLinx Software

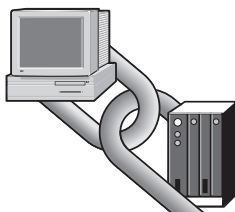

RSLinx software, 9355 series, is a communication server package that provides plant-floor device connectivity for a wide variety of applications. RSLinx software can support multiple software applications simultaneously communicating to a variety of devices on many different networks.

RSLinx software provides a user-friendly graphical interface for navigating through your network. Select a device and click to access a variety of integrated configuration and monitoring tools. A complete set of communication drivers is provided for your networking needs, including Allen-Bradley networks.

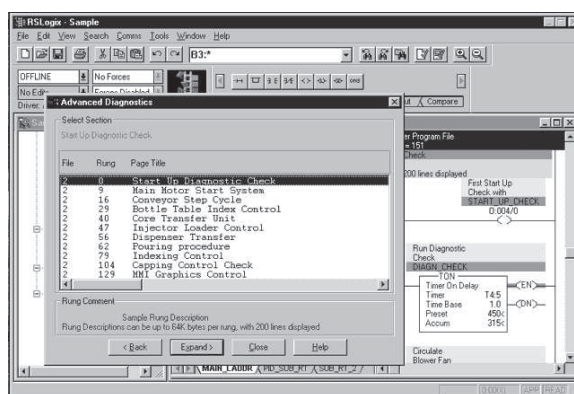

RSLinx software is available in multiple packages to meet the demand for a variety of cost and functionality requirements.

RSLinx System Requirements

Description	Value
Personal computer	Intel Pentium 100 MHz (faster processor improves performance)
Software requirements	Supported: <ul style="list-style-type: none"> • Microsoft Windows XP • Microsoft Windows 2000 • Microsoft Windows NT version 4.0 with Service Pack 3 or greater • Microsoft Windows ME • Microsoft Windows 98
RAM	32 MB min 64 MB recommended
Hard disk space	35 MB (or more, based on application requirements)
Video requirements	16-color VGA graphics display, 800 x 600 or greater resolution

In most cases, RSLinx Lite software comes bundled with controller programming packages.

Network Configuration Software

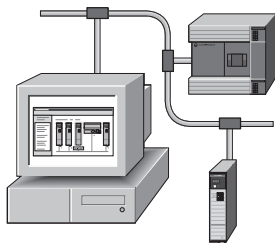

Use RSNetWorx for ControlNet (9324-CNETL3) and RSNetWorx for DeviceNet (9324-DNETL3) software to configure and schedule tools for your ControlNet or DeviceNet networks. RSNetWorx software lets you create a graphical representation of your network configuration and configure the parameters that define your network.

RSNetWorx for ControlNet software schedules network components. The software automatically calculates network bandwidth for the entire network, as well as the bandwidth used by each network component. You must have RSNetWorx software to configure and schedule the ControlNet networks in your PLC-5 programmable controller system.

RSNetWorx for DeviceNet software configures the DeviceNet I/O devices and creates the scan list. The 1771-SDN DeviceNet scanner module stores the configuration information and scan list.

RSNetWorx System Requirements

Description	ControlNet	DeviceNet	EtherNet/IP
Personal computer	Intel Pentium or Pentium-compatible		
Software requirements	Supported: <ul style="list-style-type: none"> • Microsoft Windows XP • Microsoft Windows 2000 Terminal Server • Microsoft Windows NT version 4.0 with Service Pack 6 or later • Microsoft Windows ME • Microsoft Windows 98 		
RAM	32 MB min more memory is required for large networks		
Hard disk space	Min: 115 MB (includes program files and hardware files) Full support: 168...193 MB (includes program files, online help, tutorial, and hardware files)	Min: 190 MB (includes program files and hardware files) Full support: 230...565 MB (includes program files, online help, tutorial, and hardware files)	Min: 108 MB (includes program files and hardware files) Full support: 115...125 MB (includes program files, online help, tutorial, and hardware files)
Video requirements	16-color VGA graphics adapter, 640 x 480 resolution min, 800 x 600 resolution recommended		
Other	RSLinx Lite software 2.4 or later to use RSNetWorx online	RSLinx Lite software 2.4 or later to use RSNetWorx online	RSLinx Lite software 2.41 or later to use RSNetWorx online