

# Flow Sensor

## Series PFMV



### Suction check of very small workpieces

This flow sensor enables precise suction.

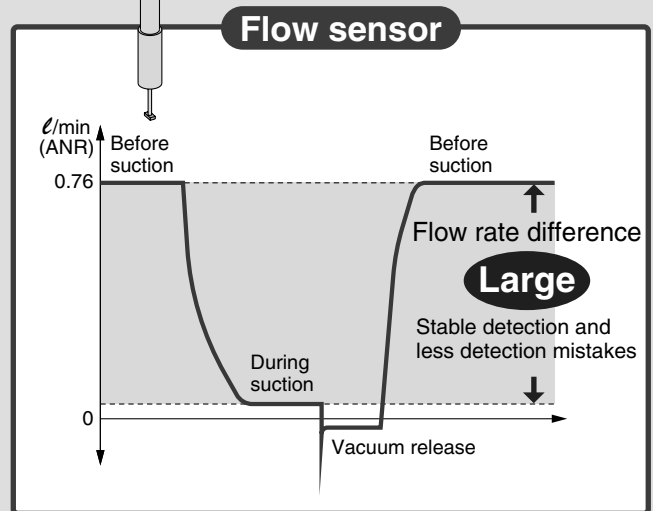
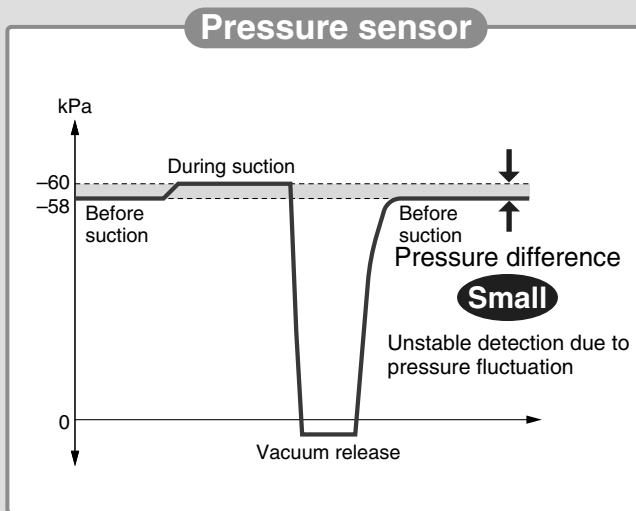
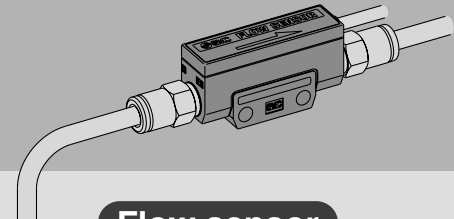

(Comparison under Nozzle diameter:  $\phi 0.3$ , Vacuum pressure:  $-60$  kPa)

- Repeatability:  $\pm 2\%$  F.S. or less

The taper-shaped flow passage in front of the sensor chip enables stable sensing.

Patent pending

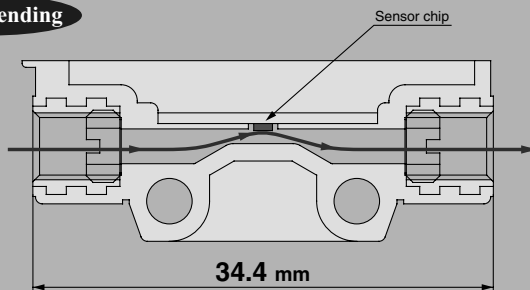

- Response speed: **5** ms or less
- Proof pressure: **500** kPa
- Grease-free
- RoHS compliant
- Flexible cable

PFM

PFMV

PF2A

PF2W

PF2D

IF

Model	Rated flow range (l/min (ANR))								
	-3	-2	-1	-0.5	0	0.5	1	2	3
PFMV	505					■			
	510					■	■		
	530					■	■	■	
	505F				■	■			
	510F			■	■	■	■		
	530F	■	■	■	■	■	■	■	■

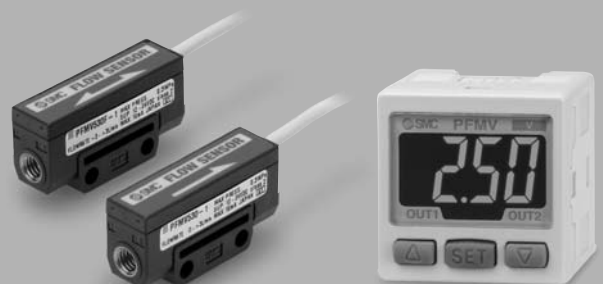

Sensor

Series PFMV5

Voltage Monitor

Series PFMV3

## Sensor

### Reduced piping space

Mountable in a space-saving location since the straight piping length is not required.

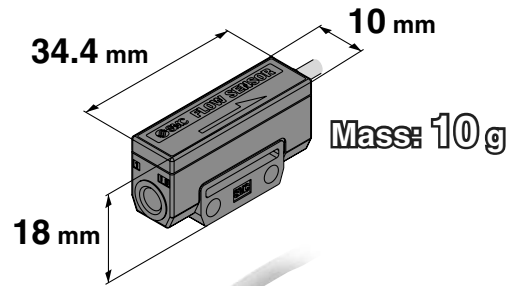
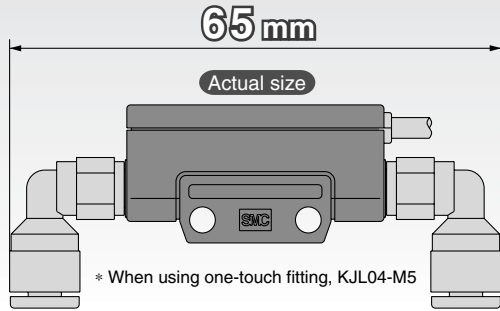

Measurement flow range (l/min)	Model
0 to 0.5	PFMV505
0 to 1	PFMV510
0 to 3	PFMV530
-0.5 to 0.5	PFMV505F
-1 to 1	PFMV510F
-3 to 3	PFMV530F

### Series PFMV5

## Voltage Monitor

A full range of sensors (6 ranges) can be covered by one monitor.

No need to select the range of connected sensors (excluding external input).



### ● Voltage display

Output voltage of the sensor is displayed.

- Settable range: 0.7 to 5.10 V
- Minimum unit setting: 0.01 V

### Series PFMV3

### ● Connectors

Easy connection and removal of wiring

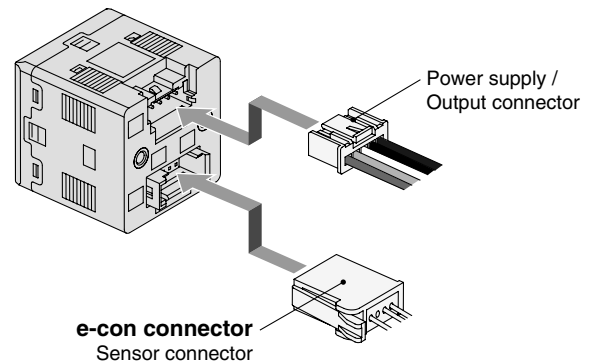

## Applications

### ● Suction check of very small workpieces

- Suction of small components can be checked.
- Highly applicable to small nozzles
- Detects nozzle clogging and crushing.

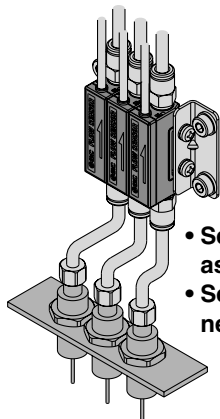
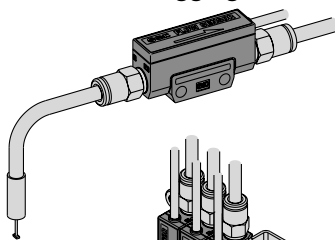

- Sensors can be mounted as a manifold.
- Sensors can be mounted near pads.

### ● Easier leakage test

- Easily detects pin holes on molded parts.

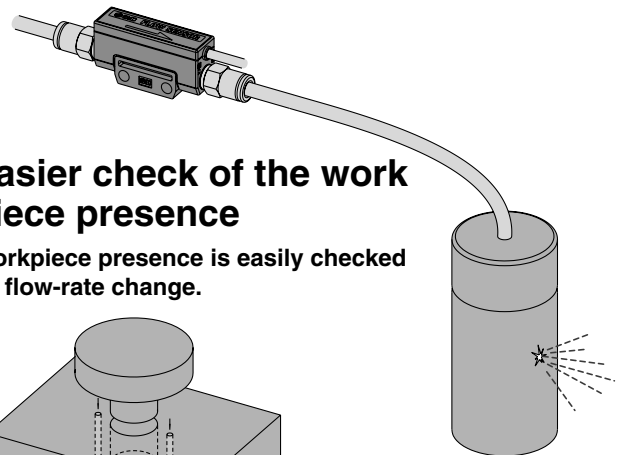

### ● Easier check of the work piece presence

- Workpiece presence is easily checked by flow-rate change.

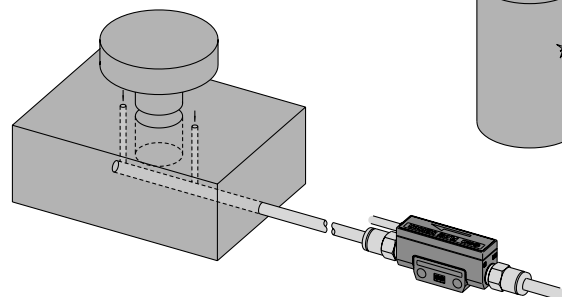

# Mountings

● Direct mount

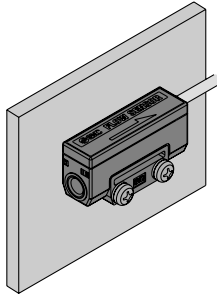

● Manifold mount

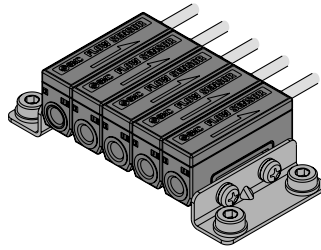

● One-side bracket mount

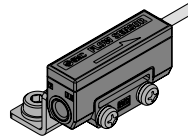

● Both-side bracket mount

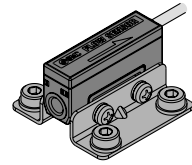

● Panel mount

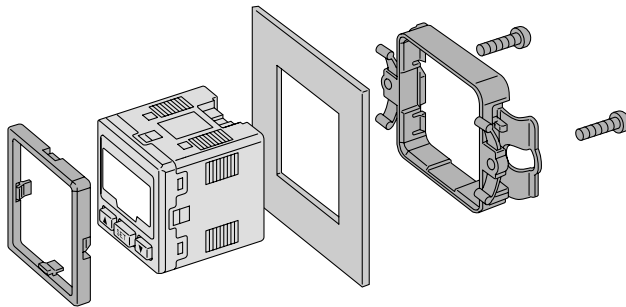

● Bracket mount

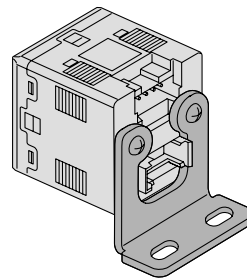

**Support for vertical and horizontal secure mounting**

- A single panel opening is sufficient.
- Reduces panel fitting work and enables space-savings.

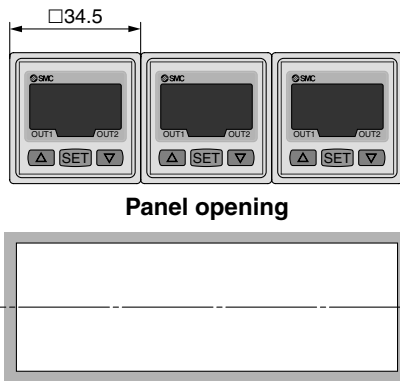

PFM

PFMV

PF2A

PF2W

PF2D

IF

# Series PFMV Model Selection

## Nozzle Diameter and Flow Characteristics (Approximate values)

Use the following graphs as a reference to select sensor measuring range.

P2: Nozzle internal pressure

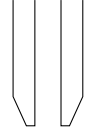

P1: Atmospheric pressure

### Nozzle Diameter – Flow Characteristics (Vacuum)

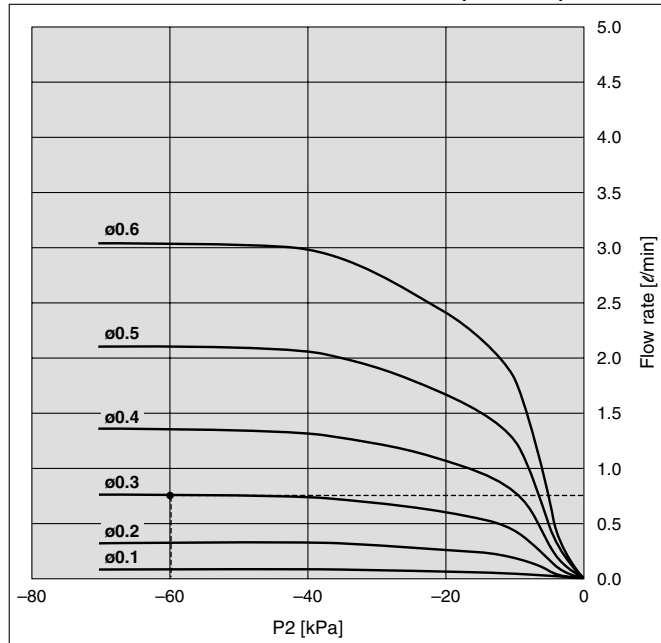

### Nozzle Diameter – Flow Characteristics (Positive pressure)

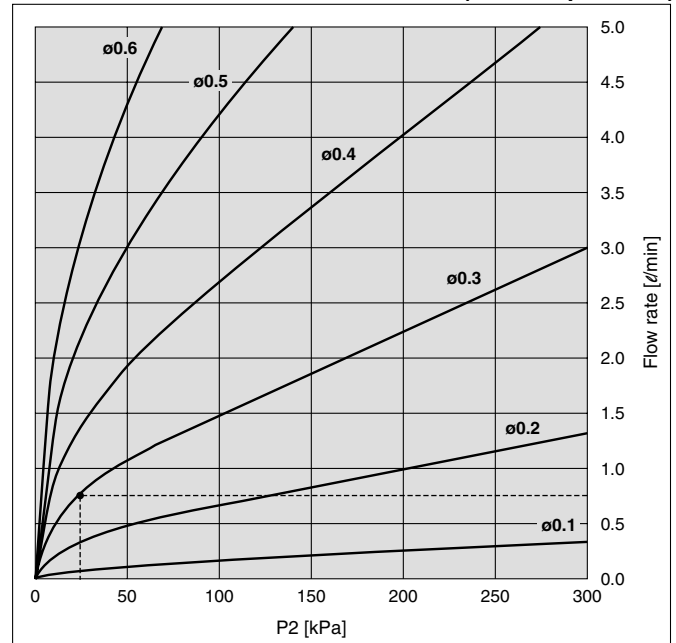

#### Example (Vacuum)

Selecting conditions:

Nozzle diameter: ø0.3 P1: 0 [kPa]  
P2: -60 [kPa]

The flow rate will be 0.7 to 0.8 [l/min] based on the graph.  
→ Select the PFMV510-1.

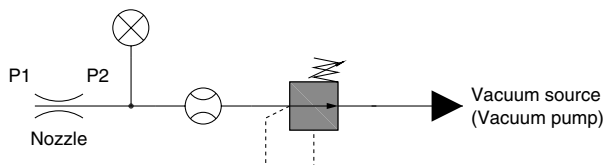

#### Example (Positive pressure)

Selecting conditions:

Nozzle diameter: ø0.3 P1: 0 [kPa]  
P2: 20 [kPa]

The flow rate will be 0.7 to 0.8 [l/min] based on the graph.  
→ Select the PFMV510-1.

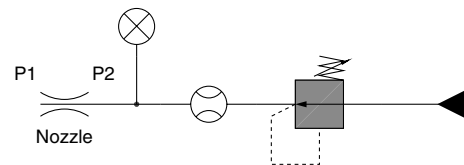

Note) Since the calculated value may not meet the approximate value due to leakage and pressure loss in the piping system, please check the result by using actual equipment.

# Flow Sensor

# Series PFMV5



## How to Order



PFMV5 **05** - 1 -      

### Measurement flow range

<b>05</b>	0.0 to 0.5 ℓ/min
<b>10</b>	0.0 to 1.0 ℓ/min
<b>30</b>	0.0 to 3.0 ℓ/min
<b>05F</b>	-0.5 to 0.5 ℓ/min
<b>10F</b>	-1.0 to 1.0 ℓ/min
<b>30F</b>	-3.0 to 3.0 ℓ/min

### Output specification

<b>1</b>	Analog output (1 to 5 V)
----------	--------------------------

### Option (shipped together)

<b>Nil</b>	None
<b>A</b>	With L-type bracket

\* 2 L-type brackets (with 2 mounting screws) are included.

### Instruction manual

<b>Nil</b>	With instruction manual (Leaflet: Japanese and English)
<b>N</b>	None

## Option/Part No.

If a single option or manifold mounting are required, order sensors with the part numbers below separately.

Part no.	Stations	Remarks
<b>ZS-36-A1</b>	For 1 station (for single unit)	2 L-type brackets, 2 mounting screws M3 x 15L
<b>ZS-36-A2</b>	For 2 stations	2 L-type brackets, 2 mounting screws M3 x 25L
<b>ZS-36-A3</b>	For 3 stations	2 L-type brackets, 2 mounting screws M3 x 35L
<b>ZS-36-A4</b>	For 4 stations	2 L-type brackets, 2 mounting screws M3 x 45L
<b>ZS-36-A5</b>	For 5 stations	2 L-type brackets, 2 mounting screws M3 x 55L

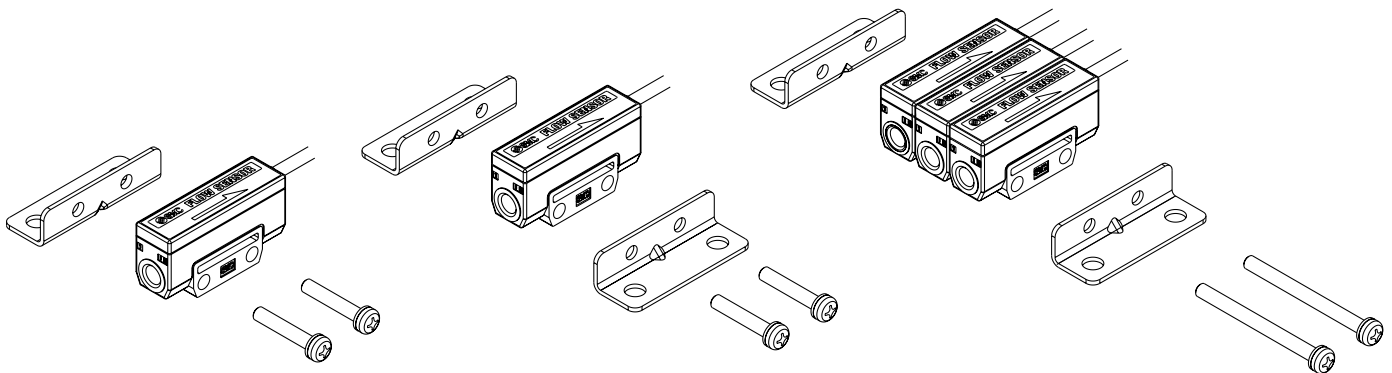

PFM

PFMV

PF2A

PF2W

PF2D

IF

# Series PFMV5

## Specifications

Model	PFMV505	PFMV510	PFMV530	PFMV505F	PFMV510F	PFMV530F
<b>Applicable fluid</b>	Dry air, N <sub>2</sub> (JIS B 8392-1 1.1.2 to 1.6.2: 2003)					
<b>Rated flow range (Flow rate range)</b> <sup>Note 1)</sup>	0 to 0.5 ℓ/min	0 to 1 ℓ/min	0 to 3 ℓ/min	-0.5 to 0.5 ℓ/min <sup>Note 2)</sup>	-1 to 1 ℓ/min <sup>Note 2)</sup>	-3 to 3 ℓ/min <sup>Note 2)</sup>
<b>Repeatability</b>	±2 F.S. or less <sup>Note 3)</sup>					
<b>Pressure characteristics</b> (Based on 0 kPa <sup>Note 4)</sup> )	±2% F.S. or less (0 to 300 kPa) ±5% F.S. or less (-70 to 0 kPa)					
<b>Temperature characteristics</b> (Based on 25°C)	±2% F.S. or less (15 to 35°C) ±5% F.S. or less (0 to 50°C)					
<b>Rated pressure range</b> <sup>Note 5)</sup>	-70 kPa to 300 kPa					
<b>Operating pressure range</b> <sup>Note 6)</sup>	-100 kPa to 400 kPa					
<b>Proof pressure</b>	500 kPa					
<b>Analog output (Non-linear output)</b>	Voltage output: 1 to 5 V, Output impedance: Approx. 1 kΩ					
<b>Response time</b>	5 ms or less (90% response)					
<b>Power supply voltage</b>	12 to 24 VDC ± 10%, Ripple (p-p) ± 10% or less (with polarity protection)					
<b>Current consumption</b>	16 mA or less					
<b>Environmental resistance</b>	<b>Enclosure</b>	IP40				
	<b>Fluid temperature</b>	0 to 50°C (with no freezing and condensation)				
	<b>Operating temperature range</b>	0 to 50°C (with no freezing and condensation)				
	<b>Stored temperature range</b>	-10 to 60°C (with no freezing and condensation)				
	<b>Operating humidity range</b>	35 to 85% R.H. (with no condensation)				
	<b>Stored humidity range</b>	35 to 85% R.H. (with no condensation)				
	<b>Withstand voltage</b>	1000 VAC for 1 min. between whole charging part and case				
	<b>Insulation resistance</b>	50 MΩ or more (500 VDC Mega) between whole charging part and case				
	<b>Vibration resistance</b>	10 to 150 Hz with a 1.5 mm amplitude, max. 98 m/s <sup>2</sup> , in each X, Y, Z direction for 2 hrs (De-energized)				
	<b>Impact resistance</b>	980 m/s <sup>2</sup> in X, Y, Z directions 3 times each (De-energized)				
	<b>Port size</b>	M5 x 0.8 (Tightening torque: 1 to 1.5 N·m)				
<b>Wetted parts material</b>	PPS, Si, Au, Stainless steel 316, C3604 (Electroless nickel plated)					
<b>Lead wire</b>	Vinyl cabtire cord, 3 cores ø2.6, 0.15 mm <sup>2</sup> , 2 m					
<b>Mass</b>	10 g (excluding lead wire)					

Note 1) Volume flow converted value under standard conditions (ANR) of 20°C, 101.3 kPa and 65% RH

Note 2) Analog output indicates 3 V when the flow rate is 0. When the flow direction is from IN to OUT, the output is changed to 5 V, and when it's from OUT to IN, the output is changed to 1 V.

Note 3) The unit % F.S. is based on the full scale of analog 4 V (1-5 V).

Note 4) 0 kPa indicates the atmospheric release.

Note 5) Pressure range that satisfies the product specifications

Note 6) Applicable pressure range

## Internal Circuits and Wiring Examples

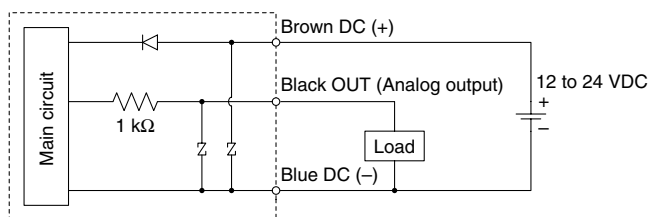

### Lead Wire Specifications

<b>Rated temperature</b>	80°C	
<b>Rated voltage</b>	1000 V	
<b>Number of wires</b>	3	
<b>Conductor</b>	<b>Material</b>	Copper alloy wire
	<b>Construction</b>	7/11/0.05 mm
	<b>External diameter</b>	0.58 mm
<b>Insulator</b>	<b>Material</b>	Cross-linked vinyl chloride (XL-PVC)
	<b>External diameter</b>	0.88 mm
	<b>Standard thickness</b>	0.15 mm
	<b>Colors</b>	Brown, Blue, Black
<b>Sheath</b>	<b>Material</b>	Oil-resistant/Heat resistant vinyl
	<b>Standard thickness</b>	0.35 mm
	<b>Color</b>	Light gray (Munsell N7 equivalent)
<b>Finished external diameter</b>	2.6 <sup>+0.1</sup> <sub>-0.15</sub>	

## Recommended Pneumatic Circuits

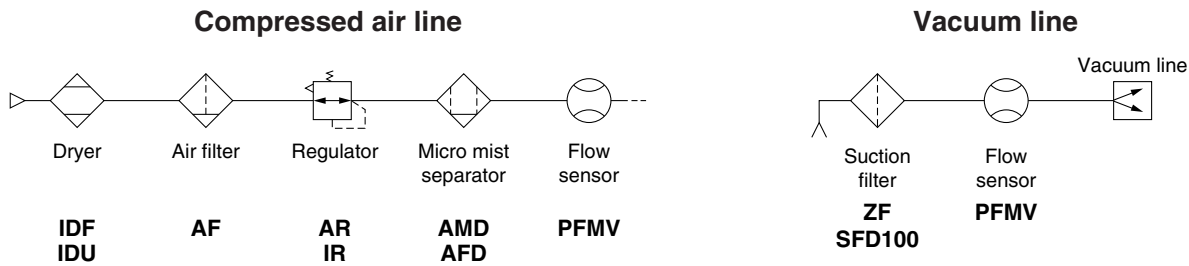

## Recommended Fittings

### One-touch Fitting/Series KQ2

Type	Tubing O.D. (mm)	Port size	Model
Male connector	4	M5 x 0.8	KQ2H04-M5
Hex. socket head male connector			KQ2S04-M5
Male elbow			KQ2L04-M5

### One-touch Mini/Series KJ

Type	Tubing O.D. (mm)	Port size	Model
Male connector	4	M5 x 0.8	KJH04-M5
Hex. socket head male connector			KJS04-M5
Male elbow			KJL04-M5

### Miniature Fitting/Series M

Type	Tubing O.D. (mm)	Port size	Model
Barb fitting for nylon tube	4	M5 x 0.8	M-5AN-4
	6		M-5AN-6

## Internal Construction

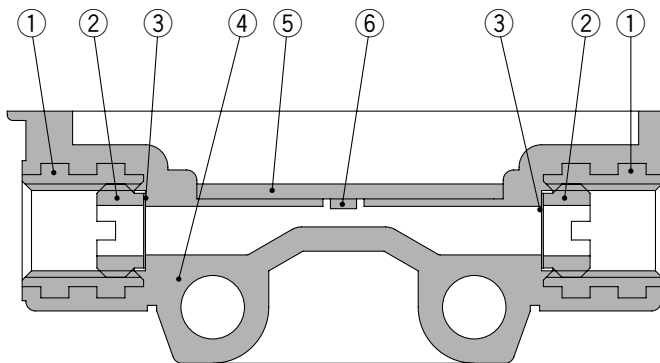

### Component Parts

No.	Description	Material
1	Fitting for piping	C3604 (Electroless nickel plated)
2	Mesh holding screw	
3	Mesh	Stainless steel 316
4	Body	PPS
5	Print circuit board	GE4F
6	Sensor chip	Si, Au

PFM

PFMV

PF2A

PF2W

PF2D

IF

## Detection Principle

This MEMS sensor chip consists of upstream temperature measuring sensor (Ru) and downstream temperature measuring sensor (Rd), which are placed symmetrically from the center of a platinum thin film coated heater (Rh) mounted on a membrane, and an ambient temperature sensor (Ra) for measuring gas temperature.

The principle is as shown in the diagram on the right. (a) When the gas is static, the temperature distribution of heated gas centered around Rh is uniform, and Ru and Rd have the same resistance. (b) When the gas flows from the left side, it upsets the balance of the temperature distribution of heated gas, and the resistance of Rd becomes greater than that of Ru.

The difference in resistance between Ru and Rd is proportional to the gas velocity, so measurement and analysis of the resistance can show the flow direction and velocity of the gas.

Ra is used to compensate the gas and/or ambient temperature.

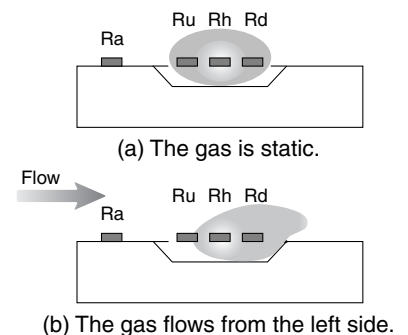

# Series PFMV5

## Analog Output (Non-linear output)

PFMV505-1

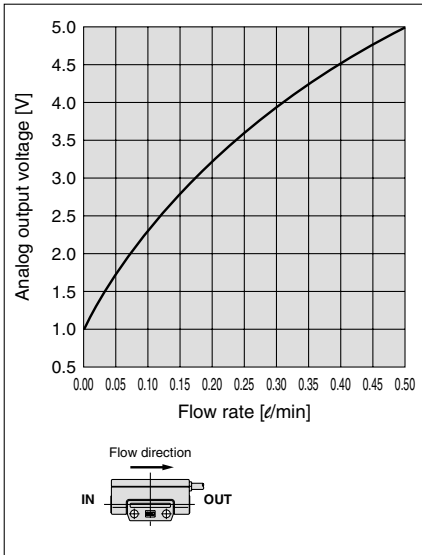

PFMV510-1

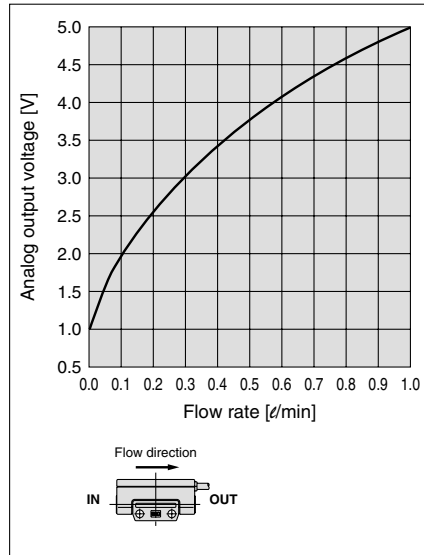

PFMV530-1

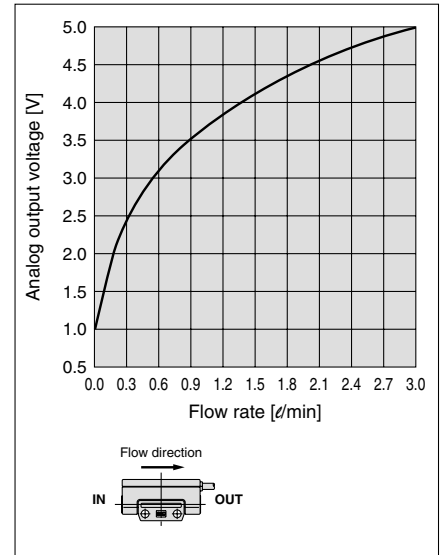

PFMV505F-1

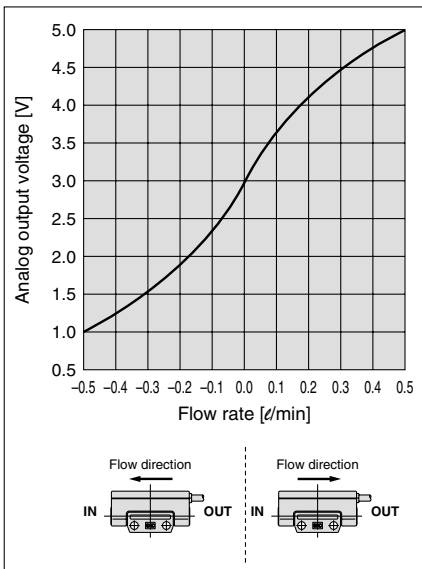

PFMV510F-1

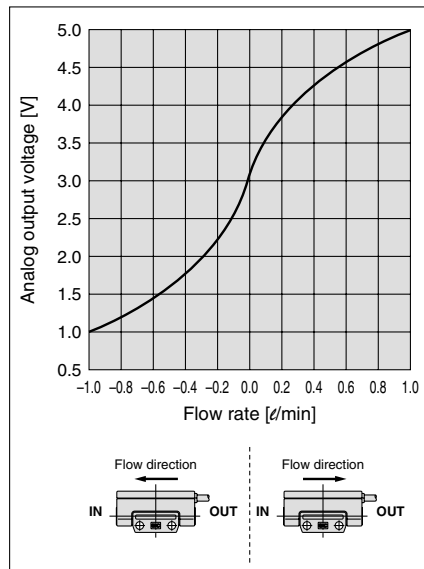

PFMV530F-1

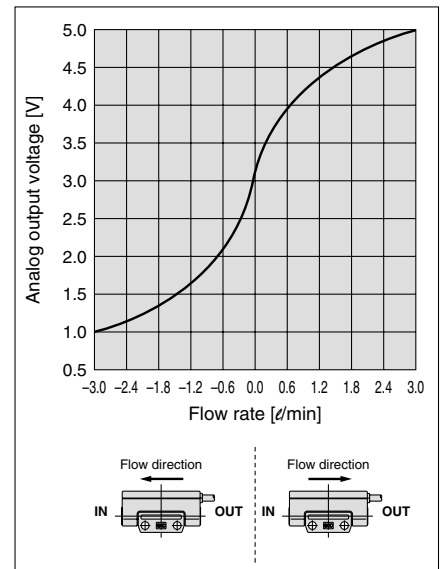

## Pressure Loss

PFMV505(F)-1

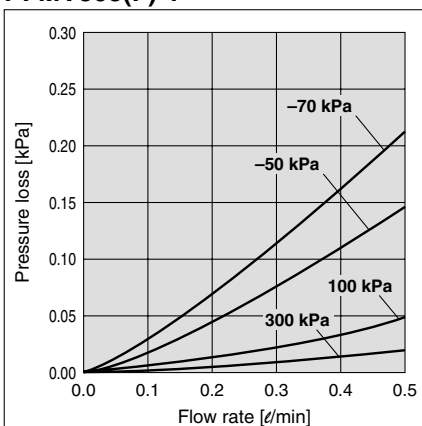

PFMV510(F)-1

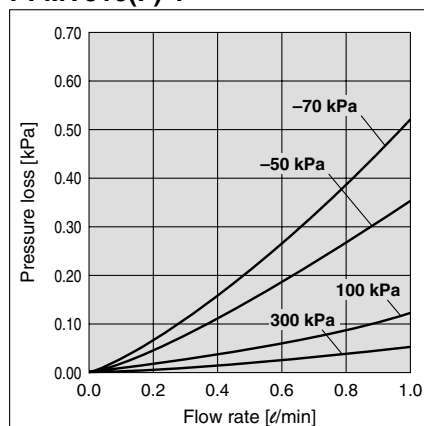

PFMV530(F)-1

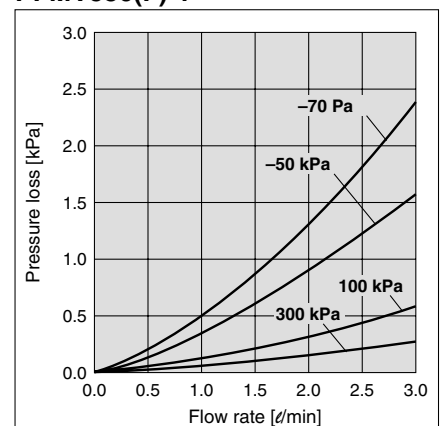



## Dimensions

PFMV5□□-1  
PFMV5□□F-1

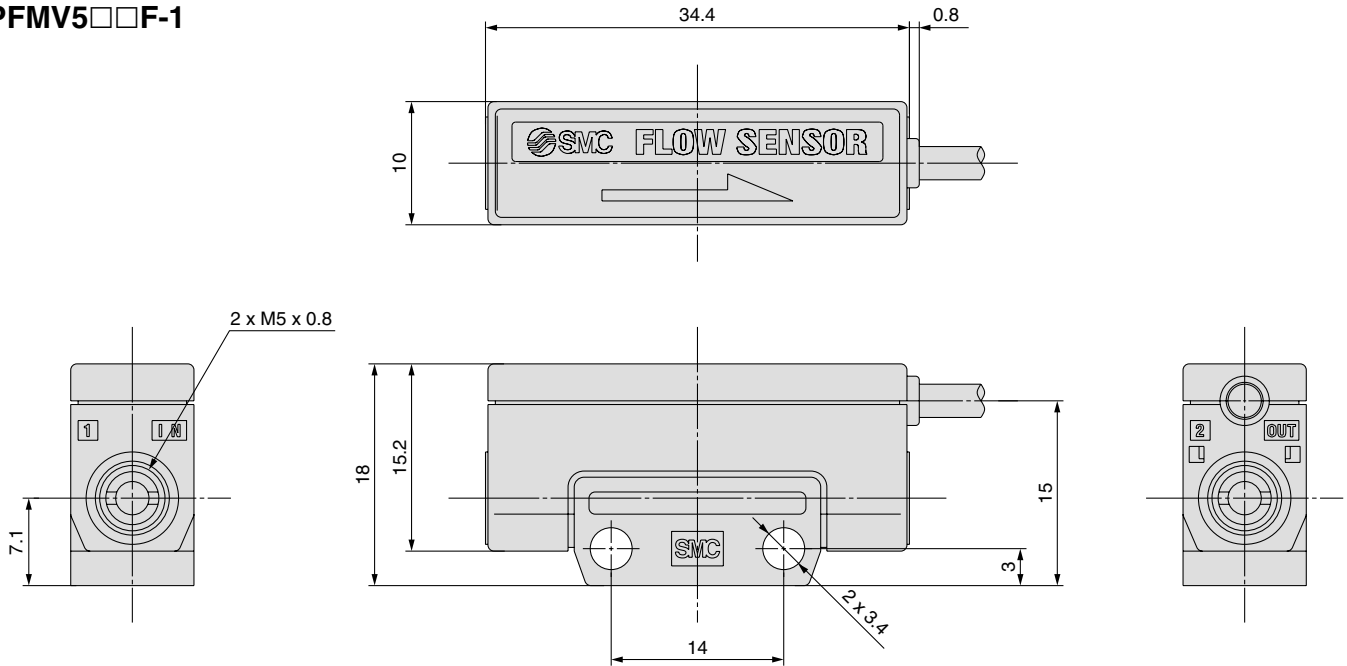

### One-side bracket

### Both-side bracket

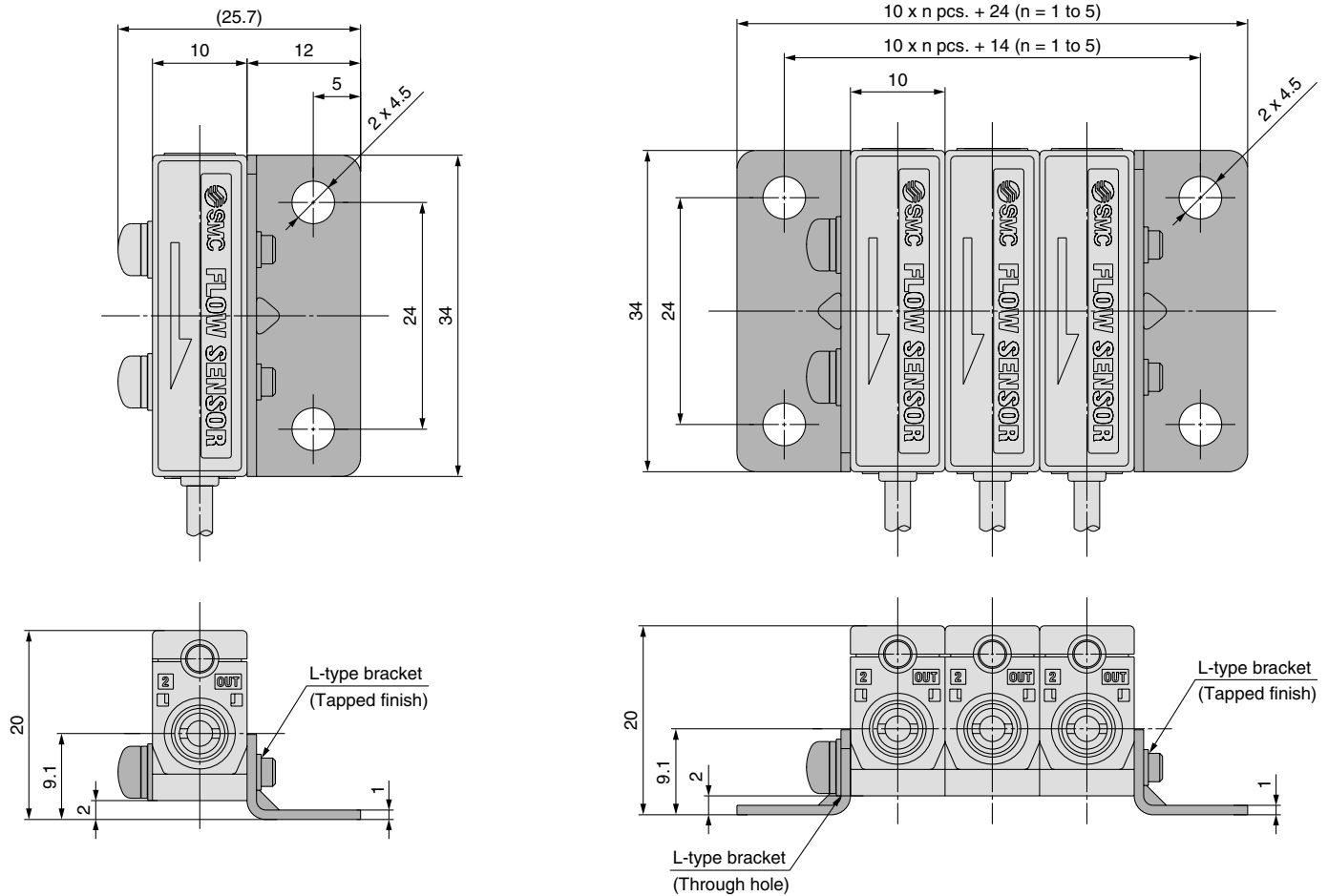

The dimensions show the PFMV5□□-1. The PFMV5□□F-1 has the same dimensions.

# Voltage Monitor for PFMV5 Series PFMV3



## How to Order

PFMV3 0 0 - M L [ ] [ ] - [ ] [ ]

### Type

3	Remote display unit
---	---------------------

### Input specification

Symbol	Content	Applicable remote type sensor unit
0	Voltage input	PFMV5□(F)-1-□□

### Output specification

0	2 NPN outputs + 1 to 5 V output
1	2 NPN outputs + 4 to 20 mA output
2	2 NPN outputs + Auto-shift input
3	2 PNP outputs + 1 to 5 V output
4	2 PNP outputs + 4 to 20 mA output
5	2 PNP outputs + Auto-shift input

### Option 1

Nil	None
L	Power supply / Output connector

Note) Cable is shipped together, but not connected.

The PFMV3 series is a monitor that displays the output voltage of the PFMV5 series.

### Option/Part No.

Description	Part no.	Note
Power supply / Output connector (2 m)	ZS-28-A	
Bracket	ZS-28-B	With M3 x 5 ℓ (2 pcs.)
Sensor connector	ZS-28-C	1 pc.
Panel mount adapter	ZS-27-C	With M3 x 8 ℓ (2 pcs.)
Panel mount adapter + Front protective cover	ZS-27-D	With M3 x 8 ℓ (2 pcs.)

### Instruction manual

Nil	With instruction manual (Leaflet: Japanese and English)
N	None

### Calibration certificate

Nil	None
A	With calibration certificate

\* The certificate is written in both English and Japanese. Please consult with us for other languages.

### Option 3

Nil	None
G	With sensor connector

Note) Connector is shipped together, but not connected.

### Option 2

Nil	None
E	Bracket
B	Panel mount adapter
D	Panel mount adapter + Front protective cover

Note) Options are shipped together, but not assembled.

## Specifications

Model	Series PFMV3□□
<b>Applicable sensor</b>	Series PFMV505(F), PFMV510(F), PFMV530(F)
<b>Displayable range</b>	0.70 to 5.10 V: The voltage under 0.7 V is displayed as “LLL” and that of 5.1 V or more is displayed as “HHH”.
<b>Settable range</b>	0.70 to 5.10 V
<b>Minimum unit setting</b>	0.01 V
<b>Indication unit</b>	V
<b>Power supply voltage</b>	12 to 24 VDC (Ripple $\pm$ 10% or less) (with polarity protection)
<b>Current consumption</b>	50 mA or less
<b>Hysteresis</b> <small>Note 1)</small>	Hysteresis mode: Variable, Window comparator mode: Variable
<b>Switch output</b>	NPN or PNP open collector output: 2 outputs Max. load current: 80 mA, Max. load voltage 30 VDC (at NPN output), Residual voltage 1 V or less (at load current 80 mA), With short-circuit protection
<b>Response time</b>	Switch output: 2 ms (10 ms, 50 ms, 0.5 s, 1 s can be selected.) <small>Note 2)</small>
<b>Repeatability</b>	$\pm$ 0.1% F.S. or less, , Analog output accuracy: $\pm$ 0.3% F.S. or less
<b>Analog output</b>	Voltage output: 1 to 5 VDC, Output impedance: Approx. 1 k $\Omega$ Current output: 4 to 20 mADC, Max. load impedance: 600 $\Omega$ (at 24 VDC) Min. load impedance: 50 $\Omega$ , Accuracy: $\pm$ 1% F.S. or less (relative to display value), Response: 0.1 s (90% response or less)
<b>Display accuracy</b>	$\pm$ 0.5% F.S. $\pm$ 1 digit or less
<b>Display method</b>	3+1/2-digit, 7-segment LED 2-color display (Red/Green) Updated cycle: 10 times/sec
<b>Status LEDs</b>	OUT1: Illuminates when output is turned ON (Green). OUT2: Illuminates when output is turned ON (Red).
<b>External input (Auto-shift input)</b> <small>Note 3)</small>	No-voltage input (Reed or Solid state), LOW level input 5 msec or more, LOW level 0.4 V or less
<b>Enclosure</b>	IP40
<b>Operating temperature range</b>	Operating: 0 to 50°C Stored: -10 to 60°C (with no freezing and condensation)
<b>Operating humidity range</b>	Operating, Stored: 35 to 85% R.H. (with no condensation)
<b>Withstand voltage</b>	1000 VAC for 1 min. between whole charging part and live part
<b>Insulation resistance</b>	50 M $\Omega$ or more (500 VDC Mega) between whole charging part and live part
<b>Vibration resistance</b>	10 to 150 Hz with a 1.5 mm amplitude or 98 m/s <sup>2</sup> acceleration, in each X, Y, Z direction for 2 hrs, whichever is smaller (de-energized)
<b>Impact resistance</b>	100 m/s <sup>2</sup> in X, Y, Z directions 3 times each (De-energized)
<b>Temperature characteristics</b>	$\pm$ 0.5% F.S. or less (Based on 25°C)
<b>Connection</b>	Power supply / Output connection: 5P connector, Sensor connection: 4P connector (For cable specifications, refer to page 961.)
<b>Material</b>	Front case, Rear case: PBT
<b>Mass</b>	30 g (without cable) 85 g (with cable)

Note 1) Set to hysteresis mode at the time of shipment from the factory. Can be changed to window comparator mode using push-buttons.

Note 2) This is the response when the setting value is set to 90% to a 0 to 100% of step input.

Note 3) Auto-shift function is turned OFF at the time of shipment from the factory. Use it after auto-shift function is turned ON using push-buttons.

## Analog Output

1 to 5 VDC

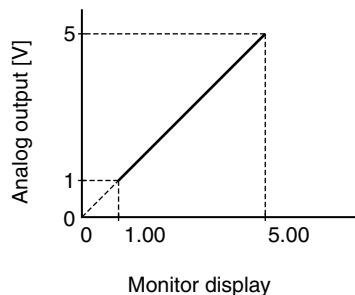

4 to 20 mADC

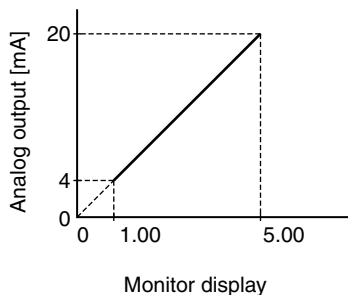

PFM

PFMV

PF2A

PF2W

PF2D

IF

# Series PFMV3

## Internal Circuits

### PFMV300

NPN open collector output: 2 outputs  
 Max. 30 V, 80 mA, residual voltage 1 V or less  
 Analog output: 1 to 5 V  
 Output impedance: Approx. 1 k $\Omega$

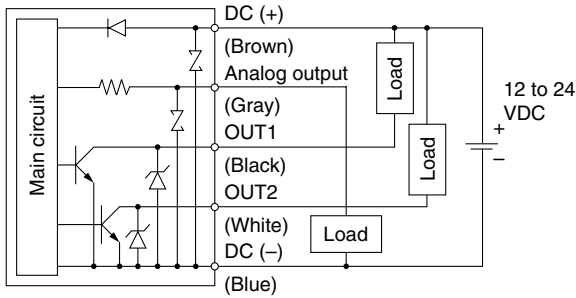

### PFMV303

PNP open collector output: 2 outputs  
 Max. 80 mA, residual voltage 1 V or less  
 Analog output: 1 to 5 V  
 Output impedance: Approx. 1 k $\Omega$

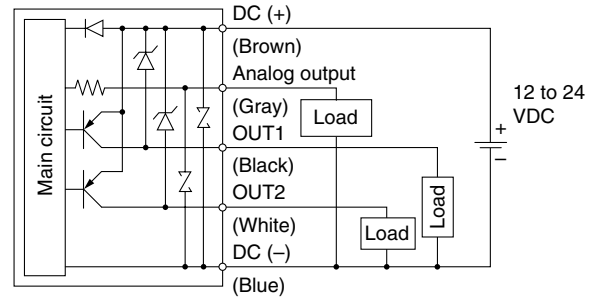

### PFMV301

NPN open collector output: 2 outputs  
 Max. 30 V, 80 mA, residual voltage 1 V or less  
 Analog output: 4 to 20 mA  
 Max. load impedance: 300  $\Omega$  (at 12 VDC) 600  $\Omega$  (at 24 VDC)  
 Min. load impedance: 50  $\Omega$

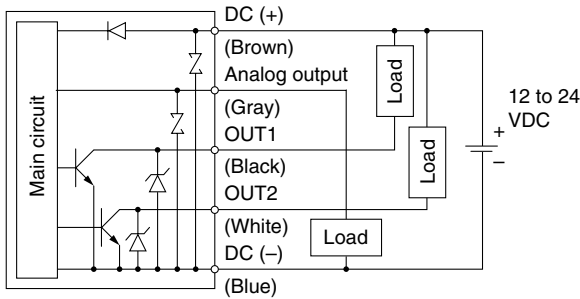

### PFMV304

PNP open collector output: 2 outputs  
 Max. 80 mA, residual voltage 1 V or less  
 Analog output: 4 to 20 mA  
 Max. load impedance: 300  $\Omega$  (at 12 VDC) 600  $\Omega$  (at 24 VDC)  
 Min. load impedance: 50  $\Omega$

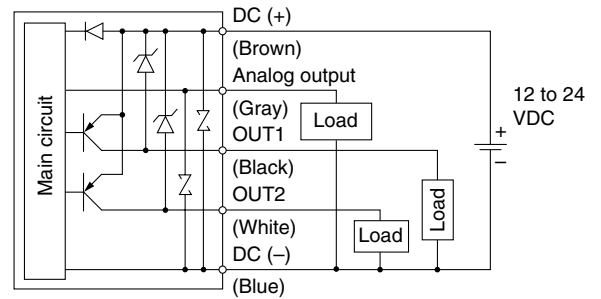

### PFMV302

NPN open collector output with auto-shift input: 2 outputs  
 Max. 30 V, 80 mA, residual voltage 1 V or less

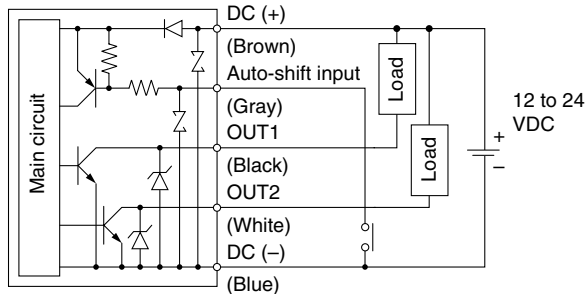

### PFMV305

PNP open collector output with auto-shift input: 2 outputs  
 Max. 80 mA, residual voltage 1 V or less

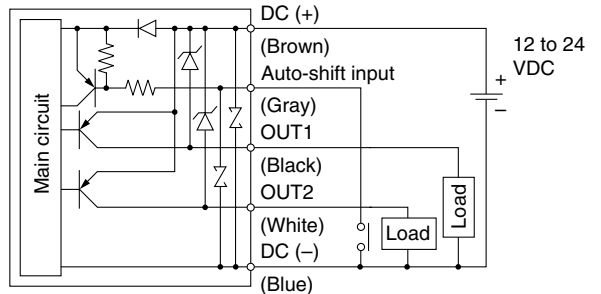

## Descriptions

### LCD Display

Shows the current voltage, mode setting, and error code. Four display modes are available, some of which use indications that are fixed either red or green, and others use indications that change from green to red.

### Output (OUT1) Indicator (Green)

Lights when the output (OUT1) is turned on.

### △ Button

Used for mode selection and increasing the ON/OFF setting value. Also used to switch to peak display mode.

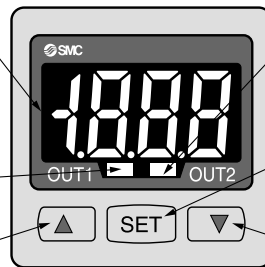

### Output (OUT2) Indicator (Red)

Lights when the output (OUT2) is turned on.

### SET Button

Used to activate mode changes and new setting values.

### ▽ Button

Used for mode selection and decreasing the ON/OFF setting value. Also used to switch to bottom display mode.

PFM

PFMV

PF2A

PF2W

PF2D

IF

# Series PFMV3

## Dimensions

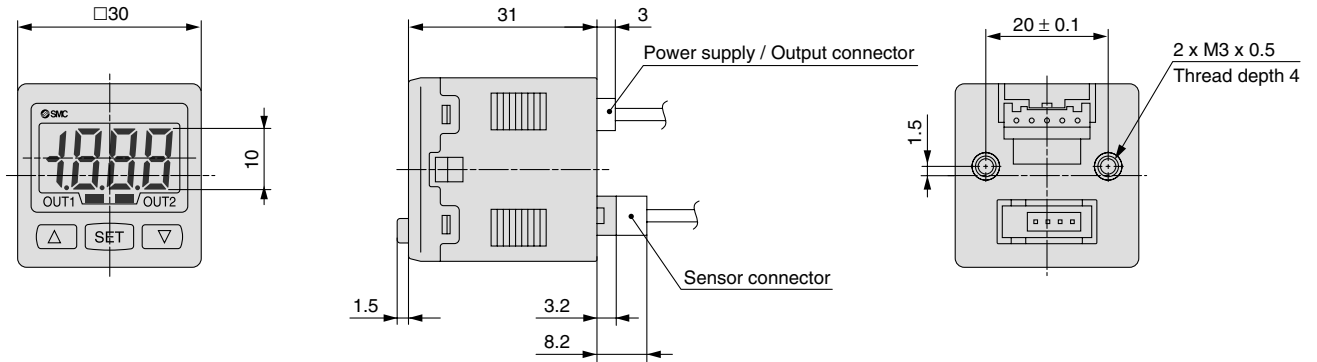

### Sensor connector (ZS-28-C)

Pin no.	Terminal name
1	DC (+)
2	N.C.
3	DC (-)
4	IN

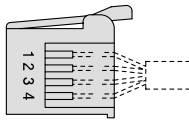

\* 1 to 5 V (Sensor output)

### With bracket

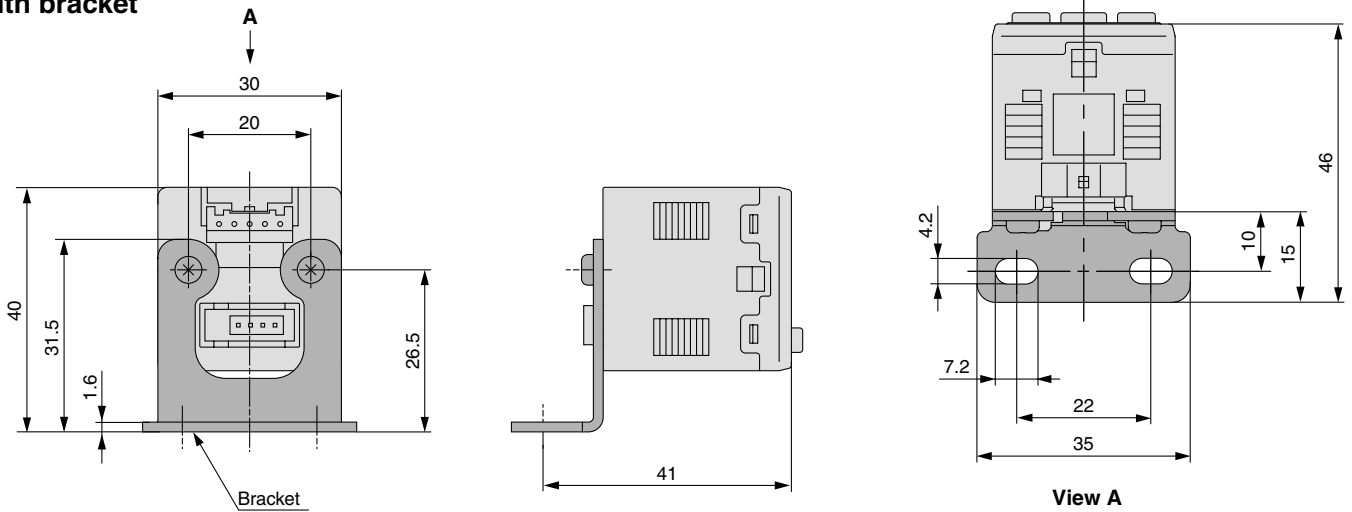

### With panel mount adapter

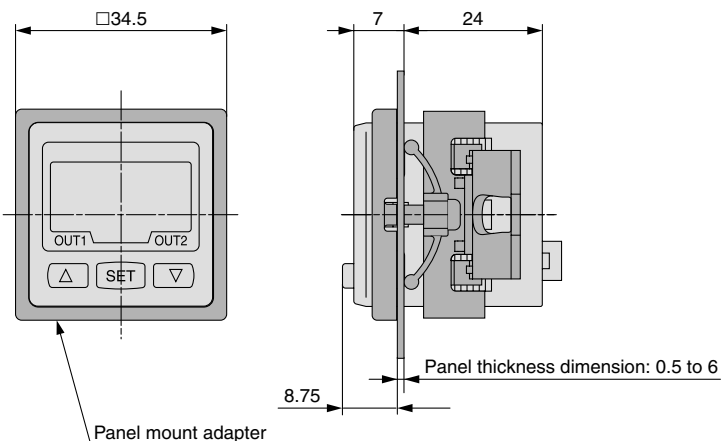

### With panel mount adapter + Front protective cover

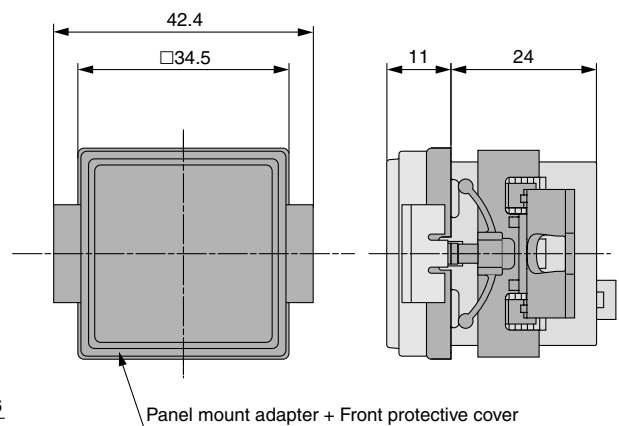

## Dimensions

### Panel fitting dimensions

#### Secure mounting of n pcs. (2 or more) switches (Horizontal)

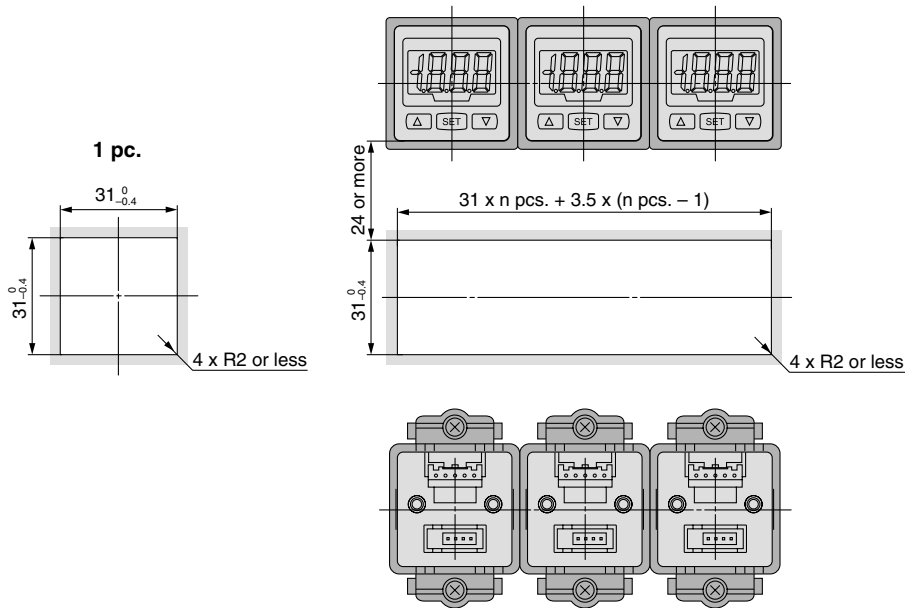

#### Secure mounting of n pcs. (2 or more) switches (Vertical)

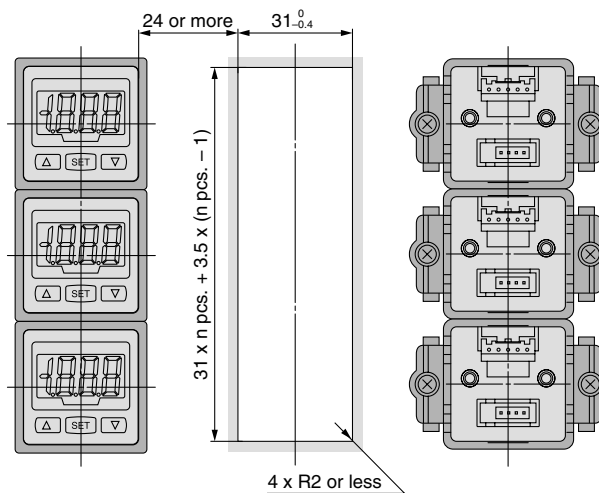

Note) If a bend (R) is used, limit it to R2 or less.

### Power supply / Output connector (ZS-28-A)

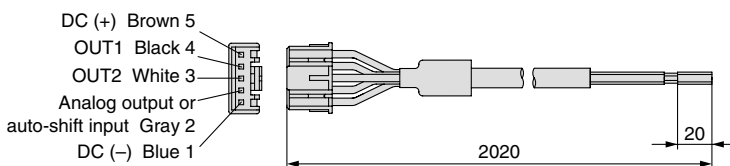

### Cable Specifications

<b>Rated temperature</b>		105°C
<b>Rated voltage</b>		300 V
<b>Number of wires</b>		5
<b>Conductor</b>	<b>Nominal cross section area</b>	0.2 mm <sup>2</sup>
	<b>Material</b>	Soft copper wire
	<b>Construction</b>	40 pcs. / 0.08 mm
	<b>External diameter</b>	0.58 mm
<b>Insulator</b>	<b>Material</b>	Cross-linked vinyl chloride resin compound
	<b>External diameter</b>	Approx. 1.12 mm
	<b>Standard thickness</b>	0.27 mm
<b>Sheath</b>	<b>Colors</b>	Brown, Black, White, Gray, Blue
	<b>Material</b>	Oil-resistant vinyl chloride resin compound
	<b>Standard thickness</b>	0.5 mm
<b>Color</b>		Light gray (Munsell N7)
<b>Finished external diameter</b>		ø4.1

PFM

PFMV

PF2A

PF2W

PF2D

IF

# Series PFMV3 Function Details

## Output operation

The output operation can be selected from the following:  
Output (hysteresis mode and window comparator mode) corresponding to receiving voltage

At the time of shipment from the factory, it is set to hysteresis mode and reverse output.

## Displayed values

The monitor receives the output voltage of the connected sensor and displays the received voltage. The unit is [V] and the voltage is displayed at 0.01 V intervals.

However, the voltage under 0.70 V is displayed as “LLL” and that of 5.1 V or more is displayed as “HHH”.

Since the voltage is displayed on the monitor, it doesn't rely on the sensor range.

## Indication color

The indication color can be selected for each output condition. The selection of the indication color provides visual identification of abnormal values. (The indication color depends on OUT1 setting.)

Green for ON, Red for OFF
Red for ON, Green for OFF
Red all the time
Green all the time

## Setting of response time

The flow rate may change momentarily during transition between ON (open) and OFF (closed) of the valve. It can be set so that this momentary change is not detected.

2 ms
10 ms
50 ms
0.5 s
1 s

## Auto-shift function

If the supply pressure of the air source fluctuates, the flow rate of vacuum generators such as an ejector also fluctuates. In that case, the switch may not operate properly when checking absorption. Auto-shift is a function that corrects this fluctuation.

This function sends the output corresponding to the relative change based on the flow rate when the auto shift signal is input.

Set value = 0.50: The switch turns ON and OFF when the set value increases by 0.5 V from the reference value.

Set value = -0.50: The switch turns ON and OFF when the set value decreases by 0.5 V from the reference value.

The reference value shows the voltage (= flow rate) when the auto-shift signal is input.

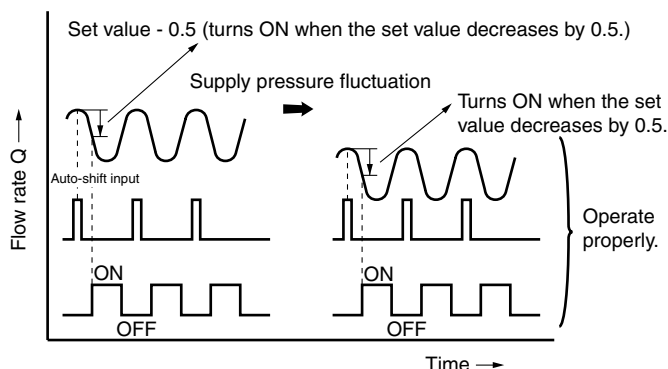
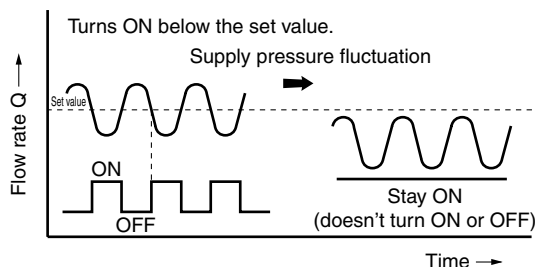

## Auto-preset function

This is a function that calculates the set value automatically. When predetermined operation is conducted while the sensor is connected, the set value is calculated and decided automatically by changing the flow rate. (Fine adjustment is available.)

## Selection of power-saving mode

The power-saving mode can be selected. With this function, if no buttons are pressed for 30 sec., it shifts to power-saving mode.

At the time of shipment from the factory, the product is set to the normal mode (the power-saving mode is turned off). (When power-saving mode is activated, the decimal point flashes.)

## Setting of secret code

The user can select whether a secret code must be entered to release key lock.

At the time of shipment from the factory, it is set such that the secret code is not required.

## Peak/Bottom value indication

The maximum (minimum) voltage is detected and updated from when the power supply is turned on. In peak (bottom) value indication mode, this maximum (minimum) voltage is displayed.

## Keylock function

Prevents operation errors such as accidentally changing setting values.

## Error indication function

When an error or abnormality arises, the location and contents are displayed.

Description	Contents	Action
Input voltage error	The voltage outside the applicable indication range is input.	Check the input voltage.
System error	Possibility of internal circuit damage before factory adjustment.	Stop operation immediately and contact SMC.
	System error. Possibility of data memorizing failure or internal circuit damage.	Reset the unit, and carry out all settings again.

If the error or abnormality cannot be solved by the action above, please contact SMC for further investigation.

## Reference value correcting function

If the displayed value doesn't become 1.00 due to the difference of the analog output of the connected sensors PFMV505, 510 and 530, the reference value will compulsively be set to 1.00.

When sensors PFMV505F, 510F and 530F are connected, the reference value will compulsively be set to 3.00.

Press the  $\Delta$  and  $\nabla$  buttons simultaneously for 1 second or more when the flow rate is zero (The display flashes when successfully corrected).

The effective range of the correcting function is from  $1.00 \pm 0.2$  V or  $3.00 \pm 0.2$  V. If the monitor is operated outside this range, it displays “Er4” and the reference value won't be corrected. Be sure to operate the monitor when the flow rate is zero.

When the PFM505 is used and the flow rate is applied, please pay attention to the following point. If this correcting function is applied around 3.00 V, the reference value will be changed and the function won't work properly. If the monitor is improperly operated, return the flow rate to zero and operate the monitor again.





# Series PFMV5

## Specific Product Precautions 1

Be sure to read before handling.

Refer to front matters 58 and 59 for Safety Instructions and pages 892 to 896 for Flow Switch Precautions.

### ■ Flow Sensor

#### Design and Selection

#### ⚠ Warning

##### 1. Operate the sensor only within the specified voltage.

Use of the sensor outside of the specified voltage range can cause not only a malfunction and damage to the sensor, but it can also cause electrocution and fire.

##### 2. Be sure to verify the applicable fluid.

The sensors do not have an explosion proof rating. To prevent possible fire hazard, do not use with flammable gases.

##### 3. Use the sensor within the specified flow rate measurement and operating pressure.

Operating beyond the specified flow rate and operating pressure can damage the sensor.

##### 4. Never use flammable fluids and/or permeable fluids.

They may cause a fire, an explosion or corrosion.

\* Refer to the MSDS (Material Safety Data Sheet) when using chemicals.

##### 5. Be sure to use the sensor within the specified ambient and fluid temperatures.

If the ambient or fluid temperatures exceed the specified range, it may damage the sensor.

Even if they are in the specified range, do not use it in a place where condensation occurs in the piping.

##### 6. To prevent damage due to failure and/or malfunction of the product, establish a backup system such as a fail-safe system which enables multiple-stage type operation of the equipment and machinery.

##### 7. When the product is for an interlock circuit, the following points should be noted.

- Provide double interlocking through another system (mechanical protection function, etc.).
- Perform checks to ensure the product is operating properly, as there is a risk of injury.

#### ⚠ Caution

##### 1. Ensure sufficient space for maintenance activities.

Provide space required for maintenance.

##### 2. The direct-current power supply to combine should be UL authorized power supply.

(1) Limited voltage current circuit in accordance with UL 508.

A circuit in which power is supplied by the secondary coil of a transformer that meets the following conditions.

- Maximum voltage (with no load):

30 Vrms (42.4 V peak) or less

- Maximum current:

(1) 8 A or less (including when short circuited)

(2) limited by circuit protector (such as fuse) with the following ratings.

No load voltage (V peak)	Max. current rating
0 to 20 [V]	5.0
Above 20 to 30 [V]	100 Peak voltage

(2) A circuit using max. 30 Vrms or less (42.4 V peak), which is powered by UL1310 or UL1585 compatible Class-2 power supply.

#### ⚠ Caution

##### 3. When the sensor is used for suction check

When the sensor is used to check the suction, select the flow rate range based on the operating vacuum pressure and suction nozzle diameter.

Refer to page 950, "Nozzle Diameter and Flow Characteristics."

##### 4. Pay attention to the response speed.

When the sensor is used to check the suction, the response speed of the sensor might be delayed due to the piping volume between the suction nozzle and sensor. Therefore, take measures to reduce the piping volume.

##### 5. The analog output may fluctuate by 2 to 3% for 5 minutes after the power is supplied.

#### Mounting

#### ⚠ Caution

##### 1. Monitor the flow direction of the fluid.

Install and connect piping so that fluid flows in the direction of the arrow indicated on the body.

##### 2. Remove dirt and dust from inside of the piping before attaching to the sensor.

##### 3. Observe the proper tightening torque.

When the sensor is tightened beyond the specified tightening torque, the sensor may be damaged.

Tightening torque for mounting part (Direct mount, Bracket mount): 0.32 ± 0.02 N·m

Tightening torque for fitting part: 1 to 1.5 N·m

##### 4. Do not mount the sensor in a place that will be used as a scaffold.

The sensor could break if subjected to excessive load such as being accidentally stepped on.

##### 5. Do not drop or bump.

Do not drop, bump, or apply excessive impacts while handling. Although the external body of a sensor (sensor case) may not be damaged, the sensor inside could be damaged and cause a malfunction.

##### 6. Hold the body of the sensor when handling.

The tensile strength of the cord is 49 N and applying a greater pulling force than this can cause a malfunction. When handling, hold the body of the sensor.

##### 7. Do not use until you can verify that equipment can operate properly.

Following mounting, repair, or retrofit, verify correct mounting by conducting suitable function and leakage tests after piping and power connections have been made.

PFM

PFMV

PF2A

PF2W

PF2D

IF



## Series PFMV5

# Specific Product Precautions 2

Be sure to read before handling.

Refer to front matters 58 and 59 for Safety Instructions and pages 892 to 896 for Flow Switch Precautions.

### Mounting

#### ⚠ Caution

8. Apply a wrench only to the designated part when installing the flow sensor in the system piping.

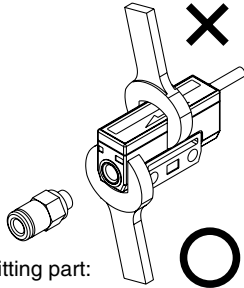

Tightening torque for fitting part:  
1 to 1.5 N·m

9. When sensors are mounted as a manifold, pay attention to the dimensions of the connected fittings.

If the dimensions of the fittings are larger than those of sensors, they will be interfered with each other and the sensors cannot be mounted properly.

### Wiring

#### ⚠ Warning

1. Verify the color and the terminal number when wiring.

Incorrect wiring can cause the sensor to be damaged and malfunction. Verify the color and the terminal number in the instruction manual when wiring.

2. Use caution not to repeatedly apply excessive bending or stretching forces to the lead wire.

Repeated pulling or bending of the lead wire may cause some of the wires to break.

3. Confirm proper insulation of wiring.

Make sure that there is no faulty wiring insulation (contact with other circuits, ground fault, improper insulation between terminals, etc.). Damage may occur due to excess current flow into a sensor.

4. Do not connect wiring while energizing the product.

The sensor and any equipment connected to it could break and malfunction.

### Operating Environment

#### ⚠ Warning

1. Never use in the presence of explosive gases.

The sensor does not have an explosion proof construction. If it is used in an environment where explosive gases are used, it may cause an explosive disaster. Therefore, never use it in such an environment.

2. Mount the sensor in a location where there is no vibration or no impact.

The sensor output may change because the sensor and connecting piping move.

3. Fix the sensor and connecting piping.

The sensor output may change because the sensor and connected piping move.

4. Do not use in an area where surges are generated.

When there are units that generate a large amount of surge in the area around a sensor, (e.g., solenoid type lifters, high frequency induction furnaces, motors, etc.) this may cause deterioration or damage to the sensor's internal circuitry. Avoid sources of surge generation and crossed lines.

5. Sensors are not equipped with surge protection against lightning.

The flow sensors are CE compliant; however, they are not equipped with surge protection against lightning. Lightning surge protection measures should be applied directly to system components as necessary.

6. Avoid using the sensor in an environment where the likelihood of splashing or spraying of liquids exists.

The sensor is an open type and should not be used in an environment exposed to splashing of water and oil.

7. Do not use the product in an environment subject to a temperature cycle.

If the product is subject to a temperature cycle other than natural changes in air temperature, the internal components of the sensor could be adversely affected.

8. Do not mount the product in locations where it is exposed to radiant heat.

This could result in damage and/or malfunction.



## Series PFMV5

# Specific Product Precautions 3

Be sure to read before handling.

Refer to front matters 58 and 59 for Safety Instructions and pages 892 to 896 for Flow Switch Precautions.

### Maintenance

#### Warning

**1. Perform periodical inspections to ensure proper operation of the sensor.**

Unexpected malfunctions may cause possible danger.

**2. Take precautions when using the sensor for an interlock circuit.**

When a sensor is used for the interlock circuit, devise a multiple interlock system to prevent trouble or malfunction, and verify the operation of the sensor and interlock function on a regular basis.

**3. Do not make any modifications (including exchanging the printed circuit boards) to the product.**

It may cause human injuries and damage.

**4. When maintenance work is performed, the following points should be noted.**

- Turn off the power supply.
- Cut off the fluid supply, drain the fluid from the piping and ensure the fluid is released to atmosphere before carrying out maintenance. Otherwise, it could cause injury.

#### Caution

**1. Do not wipe the product with chemicals such as benzene or thinner.**

Such chemicals could damage the product.

**2. Do not poke the inside of the piping port with a stick.**

The rectifier could break, making the product unable to sustain the desired performance.

**3. Do not touch terminals when energizing the product.**

It could cause electric shock, malfunction, or damage to the sensor.

### Fluid

#### Warning

**1. Check regulators and flow adjustment valves before introducing the fluid.**

If pressure or flow rate beyond the specified range are applied to the sensor, the sensor unit may be damaged.

**2. Install a filter on the inlet side when there is a possibility of foreign matter being mixed with the fluid.**

**3. Use dry air of quality compliant with JIS B 8392-1 1.1.2 to 1.6.2: 2003, ISO8573-1 1.1.2 to 1.6.2: 2001 for this product.**

If any mist or drainage present in the air attaches to the product, the sensor could be damaged or accurate measurement could be prevented.

PFM

PFMV

PF2A

PF2W

PF2D

IF



## Series PFMV5

# Specific Product Precautions 4

Be sure to read before handling.

Refer to front matters 58 and 59 for Safety Instructions and pages 892 to 896 for Flow Switch Precautions.

### Rated Flow Range

## Caution

Set the flow rate within the rated flow range.

The rated flow range is the range that satisfies the sensor specifications.

Sensor	Rated flow range						
	-3 ℓ/min	-1 ℓ/min	-0.5 ℓ/min	0 ℓ/min	0.5 ℓ/min	1 ℓ/min	3 ℓ/min
PFMV505					████████		
PFMV510					██████████		
PFMV530					████████████████████		
PFMV505F				██████████			
PFMV510F		██████████					
PFMV530F	████████████████████						



# Series PFMV3

## Specific Product Precautions 5

Be sure to read before handling.

Refer to front matters 58 and 59 for Safety Instructions and pages 892 to 896 for Flow Switch Precautions.

### ■ Flow Monitor

#### Design and Selection

#### ⚠ Warning

##### 1. Operate the switch only within the specified voltage.

Use of the switch outside of the specified voltage range can cause not only a malfunction and damage to the switch, but it can also cause electrocution and fire.

##### 2. Do not exceed the maximum allowable load specification.

A load exceeding the maximum load specification can cause damage to the switch.

##### 3. Do not use a load that generates surge voltage.

Although surge protection is installed in the circuit at the output side of the switch, damage may still occur if a surge is applied repeatedly. When working directly such an unit as relay, solenoid valve, etc., which generates surge, use a built-in surge absorbing element type.

##### 4. Monitor the internal voltage drop of a switch.

When operating below the specified voltage, it is possible that a load may be ineffective, even though the pressure switch function is normal. Therefore, the formula below should be satisfied after confirming the voltage of the load.

$$\text{Supply voltage} - \text{Internal voltage drop of switch} > \text{Minimum operating voltage of load}$$

##### 5. To prevent damage due to failure and/or malfunction of the product, establish a backup system such as a fail-safe system which enables multiple-stage type operation of the equipment and machinery.

##### 6. When the product is for an interlock circuit, the following points should be noted.

- Provide double interlocking through another system (mechanical protection function, etc.).
- Perform checks to ensure the product is operating properly, as there is a risk of injury.

#### ⚠ Caution

##### 1. Ensure sufficient space for maintenance activities.

Provide space required for maintenance.

##### 2. The direct-current power supply to combine should be UL authorized power supply.

(1) Limited voltage current circuit in accordance with UL 508.

A circuit in which power is supplied by the secondary coil of a transformer that meets the following conditions.

- Maximum voltage (with no load):

30 Vrms (42.4 V peak) or less

- Maximum current:

(1) 8 A or less (including when short circuited)

(2) limited by circuit protector (such as fuse) with the following ratings.

No load voltage (V peak)	Max. current rating
0 to 20 [V]	5.0
Above 20 to 30 [V]	100 Peak voltage

(2) A circuit using max. 30 Vrms or less (42.4 V peak), which is powered by UL1310 compatible Class-2 power supply or UL 1585 compatible Class-2 transformer (Class-2 circuit).

#### ⚠ Caution

##### 3. Data of the switch are stored even after the power supply is turned off.

Input data is stored in an EEPROM so that the data will not be lost after the flow switch is turned off. (The data can be rewritten for up to one million times, and stored for up to 20 years.)

#### Mounting

#### ⚠ Warning

##### 1. Do not drop or bump.

Do not drop, bump, or apply excessive impacts (490 m/s<sup>2</sup>) while handling. Although the external body of a switch (switch case) may not be damaged, the switch inside could be damaged and cause a malfunction.

##### 2. Do not use until you can verify that equipment can operate properly.

Following mounting, repair, or retrofit, verify correct mounting by conducting suitable function and leakage tests after piping and power connections have been made.

##### 3. Never mount the switch in a place that will be used as a scaffold during piping.

#### ⚠ Caution

##### 1. Do not mount the switch in a place that will be used as a scaffold.

The switch could break if subjected to excessive load such as being accidentally stepped on.

#### Wiring

#### ⚠ Warning

##### 1. Verify the color and the terminal number when wiring.

Incorrect wiring can cause the switch to be damaged and malfunction. Verify the color and the terminal number in the instruction manual when wiring.

##### 2. Use caution not to repeatedly apply bending or stretching forces to the lead wire.

Repeated pulling or bending of the lead wire may cause some of the wires to break.

##### 3. Confirm proper insulation of wiring.

Make sure that there is no faulty wiring insulation (contact with other circuits, ground fault, improper insulation between terminals, etc.). Damage may occur due to excess current flow into a switch.

##### 4. Do not wire in conjunction with power lines or high voltage lines.

Wire separately from power lines and high voltage lines, and avoid wiring in the same conduit with these lines. Control circuits, including switches, may malfunction due to noise from these lines.

PFM

PFMV

PF2A

PF2W

PF2D

IF



## Series PFMV3

# Specific Product Precautions 6

Be sure to read before handling.

Refer to front matters 58 and 59 for Safety Instructions and pages 892 to 896 for Flow Switch Precautions.

### Wiring

#### Warning

##### 5. Do not short-circuit a load.

Although the switch displays an overcurrent error if a load is short-circuited, there is not protection against incorrect wiring (power source polarity, etc.). Use caution to avoid wiring incorrectly.

##### 6. Do not connect wiring while energizing the product.

The switch and any equipment connected to it could break and malfunction.

### Operating Environment

#### Warning

##### 1. Never use in the presence of explosive gases.

The switch does not have an explosion proof construction. If it is used in an environment where explosive gases are used, it may cause an explosive disaster. Therefore, never use it in such an environment.

##### 2. Mount the switch in a location where there is no vibration greater than 98 m/s<sup>2</sup>, or no impact greater than 490 m/s<sup>2</sup>.

##### 3. Do not use in an area where surges are generated.

When there are units that generate a large amount of surge in the area around a pressure switch, (e.g., solenoid type lifters, high frequency induction furnaces, motors, etc.) this may cause deterioration or damage to the switch's internal circuitry. Avoid sources of surge generation and crossed lines.

##### 4. Switches are not equipped with surge protection against lightning.

The flow switches are CE compliant; however, they are not equipped with surge protection against lightning. Lightning surge protection measures should be applied directly to system components as necessary.

##### 5. Avoid using the switch in an environment where the likelihood of splashing or spraying of liquids exists.

The switch is an open type and should not be used in an environment exposed to splashing of water and oil.

##### 6. Do not use the product in an environment subject to a temperature cycle.

If the product is subject to a temperature cycle other than natural changes in air temperature, the internal components of the switch could be adversely affected.

##### 7. Do not mount the product in locations where it is exposed to radiant heat.

This could result in damage and/or malfunction.

### Maintenance

#### Warning

##### 1. Perform periodical inspections to ensure proper operation of the switch.

Unexpected malfunctions may cause possible danger.

##### 2. Take precautions when using the switch for an interlock circuit.

When a pressure switch is used for the interlock circuit, devise a multiple interlock system to prevent trouble or malfunction, and verify the operation of the switch and interlock function on a regular basis.

##### 3. Do not make any modifications (including exchanging the printed circuit boards) to the product.

It may cause human injuries and damage.

##### 4. When maintenance work is performed, the following points should be noted.

- Turn off the power supply.

#### Caution

##### 1. Do not wipe the product with chemicals such as benzene or thinner.

Such chemicals could damage the product.

##### 2. Do not touch terminals or connectors when energizing the product.

It could cause electric shock, malfunction, or damage to the switch.

### Others

#### Warning

##### 1. After the power is turned on, the switch's output remains off while a message is displayed. Therefore, start the measurement after a value is displayed.

##### 2. Perform settings after stopping control systems.

Operation reflects the new values when settings are made. However, if the power is turned OFF in that state, the settings return to the values before the change when the power is turned ON again. Make sure to press the S button to save any setting changes before turning OFF the power.



## Series PFMV3

# Specific Product Precautions 7

Be sure to read before handling.

Refer to front matters 58 and 59 for Safety Instructions and pages 892 to 896 for Flow Switch Precautions.



### Settable Range and Voltage Input Range

#### Caution

The settable rate range is the range that can be set in the switch.

The inputtable range is the range that satisfies the switch specifications (accuracy, linearity, etc.).

It is possible to set a value outside of the inputtable range if it is within the settable range, however, the specification is not guaranteed.

Item	Input voltage
	0      0.7 V      5.10 V    5.20 V
Voltage input range	
Displayable range	 LLL      HHH
Settable range	

PFM

PFMV

PF2A

PF2W

PF2D

IF