

Pressure pump

pneumatic – hydraulic, single- and double acting, pmax. 500 bar

430-1
Issue: 10/2022

Description:

These pneumatic hydraulic pressure pumps are suitable for application in simple clamping systems for actuating single-acting or double-acting clamping elements.

The pressure pumps convert a pneumatic inlet pressure into a hydraulic operating pressure. Pressure adjustment and compressed air treatment are done in an external maintenance unit.

The single-acting pressure pump clamps or unclamps the connected clamping elements by manual operation of the pedal.

The pressure pump supplies hydraulic oil until the desired operating pressure is reached. The integrated check valve keeps the oil pressure constantly. In cases of pressure loss e.g. through leakage, automatic replenishment is not given.

The pressure pump for double-acting clamping elements allows constant pressurization. Clamping and unclamping of the clamping elements is done by using the control lever of the 4/3 directional valve.

Depending on the position of the directional valve, the clamping elements will extend or retract by pressing the pedal on "PUMP".

The pedal must be pressed until the clamping elements have reached their end position and the desired oil pressure is built up. The pedal can be fixed in position by the pedal lock.

After that, clamping and unclamping of the clamping elements can be done by using the control lever of the 4/3 directional valve.

When the pedal is fixed, the double-acting pressure pump can compensate a low pressure loss automatically.



Webcode: 043001

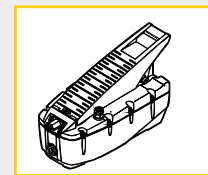

Important notice:

Scope of supply includes an user's manual. The safety and maintenance instructions must be observed.

Hydraulic oil:

- ⊗ **Recommendation:**
 - Hydraulic oil DIN 51524, HLP 22
 - Viscosity DIN 51519, ISO VG 22
- ⊗ The pressure pumps are already filled with oil. They are supplied ready for connection. It is not necessary to use a mist oiler.

Advantages:

- ⊗ Integrated pressure control valve up to 500 bar
- ⊗ Low weight, easy to transport
- ⊗ Suitable for mobile application
- ⊗ Suitable for application in explosive hazardous areas

We also design and manufacture customized variants!

HYDROKOMP
Hydraulische Komponenten GmbH

+49 6401 225999-0

sales@hydrokomp.de

Siemenstr. 16
35325 Mücke (Germany)

www.hydrokomp.de

Technology that connects

single-acting with pedal



1. Pressure inlet port
2. Pedal, "PUMP" (pressure build-up)
3. Filling and ventilation plug, at double-acting pressure pump: port for drain into reservoir
4. Pedal, "RELEASE" (pressure relief)
5. Ports for hydraulic hoses
single-acting: 1 port
double-acting: 2 ports

double-acting with 4/3 directional valve

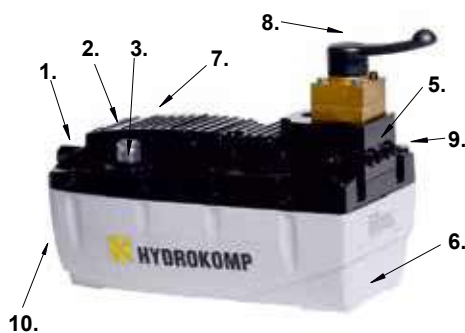

6. Pump body with reservoir
7. Pedal lock (not in picture)
8. 4/3 directional valve with control lever
9. Bleed screw
10. Oil level gauge (not in picture)

Operating pressure p_H depending from pneumatic inlet pressure p_P

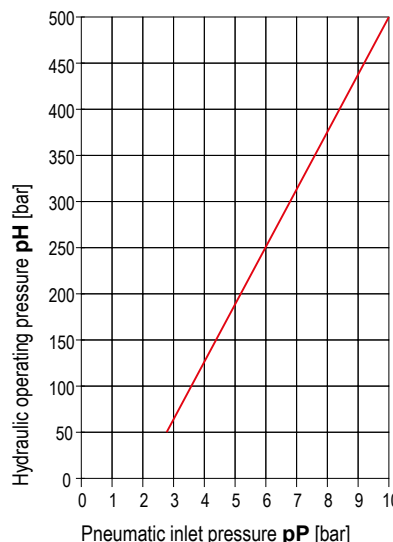

7. Pedal lock with locking pin



10. Oil level gauge





single-acting, with pedal

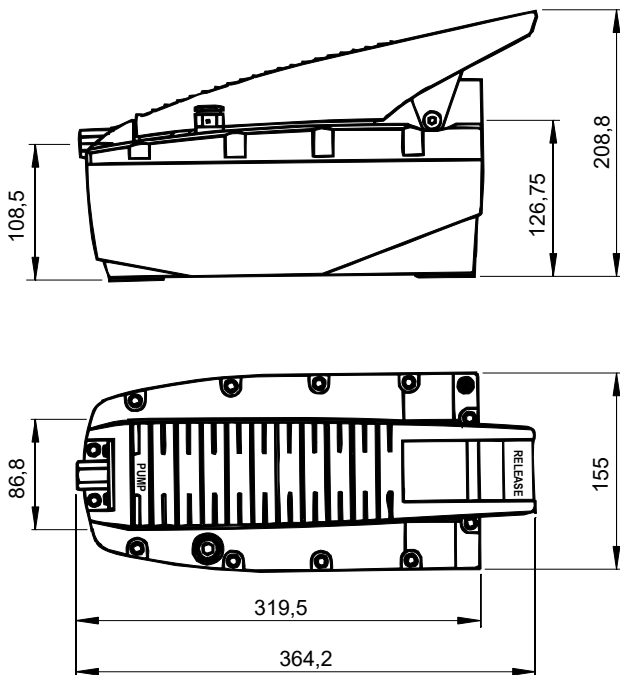

double-acting, with 4/3 directional valve

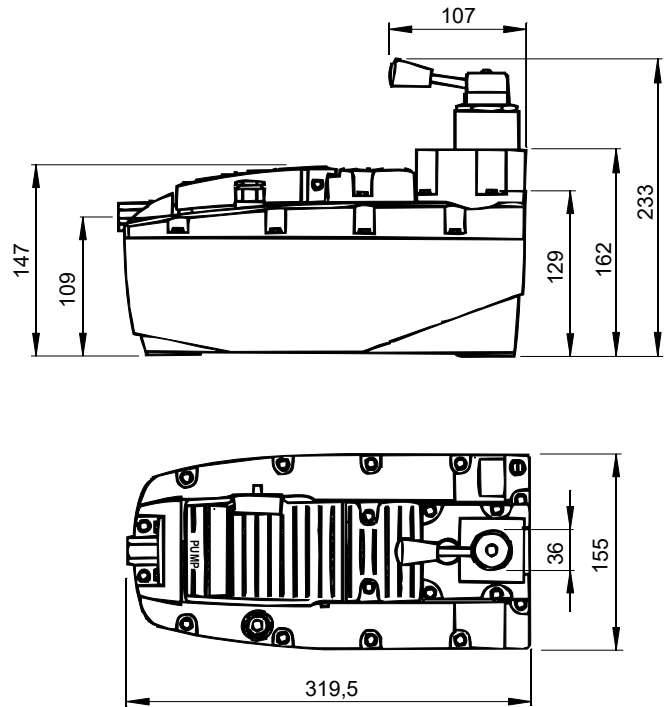

Technical data:

Pneumatic inlet pressure p_P	[bar]	2,8 - 10
Operating pressure p_H min.	[bar]	50
Operating pressure p_H max.	[bar]	500
Flow rate max. at 7 bar	[l/min]	1,4
Pneumatic port thread		G1/4
Air consumption max.	[Nl/min]	400
Hydraulic port thread		G1/4
Oil volume	[l]	2,3
Oil volume, useable	[l]	2,1
Weight, filled	[kg]	6,3
Noise level	[dB(A)/1m]	75
Order number		DLH-EW-500-001

Technical data:

Pneumatic inlet pressure p_P	[bar]	2,8 - 10
Operating pressure p_H min.	[bar]	50
Operating pressure p_H max.	[bar]	500
Flow rate max. at 7 bar	[l/min]	1,4
Pneumatic port thread		G1/4
Air consumption max.	[Nl/min]	400
Hydraulic port thread		G1/4
Oil volume	[l]	2,3
Oil volume, usable	[l]	2,1
Weight, filled	[kg]	6,8
Noise level	[dB(A)/1m]	75
Order number		DLH-DW-500-002

Circuit example, single-acting:

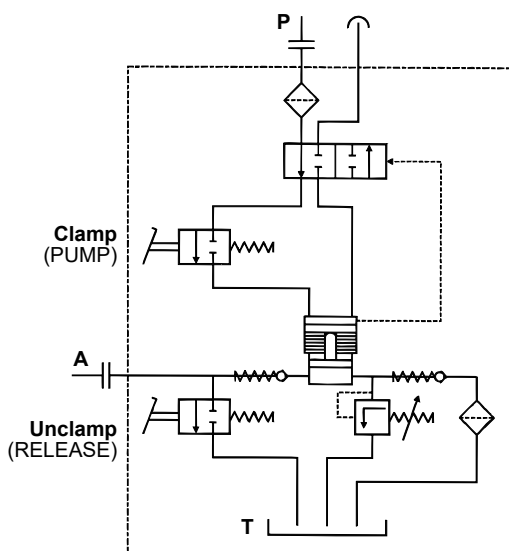

Circuit example, double-acting:

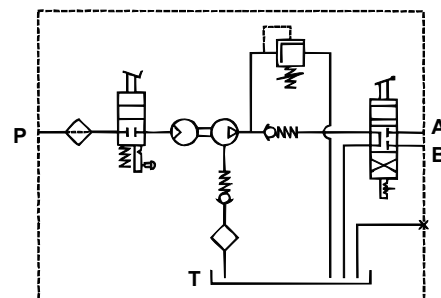

- A = Hydraulic port
- B = Hydraulic port
- P = Pneumatic port
- T = Oil reservoir