

Data sheet

Pressure gauge cutting ring fitt. 8 L-G 1/4", Zinc plated steel

Item number:

MAVE 8 LR



Example illustration

Item description

Materials:

Steel screw connections: Body: zinc-plated steel, if required, elastomer seal present: NBR, **stainless steel screw connections & NC compression ring fittings:** Body: 1.4571, if required, elastomer seal present: FKM

Temperature range:

Steel screw connections: -40°C up to max. +120°C (with elastomer seal: -35°C up to max. +100°C), **stainless steel screw connections & NC compression ring fittings:** -60°C up to max. +400°C (with elastomer seal: -20°C up to max. +200°C, NC screw connections upon request up to +550°C)

Montage cutting ring screw connections and NC compression ring fittings

- 1) Cut the tube away at a right angle and lightly deburr and clean the inside and outside. Do not use a tube cutter. In the case of thin-walled or soft pipes a reinforcing ring must be used.
- 2) Thoroughly oil the socket threads and cone, inner union nuts and cutting ring. For stainless steel cutting ring connections PASTE ES must be used (optional for NC screw connections).
- 3) Push the union nut and cutting ring onto the tube. Ensure the correct position of the cutting ring/NC compression ring - otherwise the assembly will be incorrect.
- 4) Loosen the union nut as far as possible by hand. Attach the marking of the union nut for checking the specified rotations. Press tube in the cone until the stop. Tighten the union nut with screw wrench approx. 1 rotation. The tube must not be rotated.
- 5) Loosen the union nut to check the assembly. **Cutting ring:** The raised tube material must cover the front cutting ring area. If not, retighten slightly. Due to the spring effect of the cutting ring, this can still be rotated - no functional error. **NC compression ring:** The compression ring can no longer be displaced.
- 6) Final assembly: Assemble the union nuts on sockets until there is a noticeable increase in force. Then tighten with 1/4 - 1/2 rotation (cutting ring fitting), or 3/4 rotation (NC compression ring fitting).

Required tube quality:

Steel screw connections: Seamless precision hydraulic pipes according to EN 10305-4 (DIN 2445/2), tolerances as per DIN 2391, quality grade C, **Stainless steel screw connections & NC compression ring fittings:** Seamless stainless steel pipes

according to DIN EN ISO 1127, tolerance class D4/T3 (NC compression ring fittings may only be processed with pipes made of the material 1.4571.)

Advantages of NC-compression ring fittings over cutting ring fittings:

- Compatible with all cutting ring fittings according to DIN EN ISO 8434-1 (DIN 2353). Also resistant to dynamic loads such as vibrations and pulsations. It can be loosened and screwed back in as often as is necessary.
- In contrast to a cutting ring the NC compression ring is not hardened, therefore it cannot rust and has good chemical resistance.
- Lubrication of the nut thread for initial assembly is not necessary,
- Vacuum tightness $Q < 10^8$ mbar l/s,
- Ideal for use in gas and water area

Properties

Material	Zinc plated steel
Model series	light model series
Pipe nozzle Ø [mm]	8 L
Pressure gauge connection	G 1/4"
Operating pressure [bar]	315
Temperature range [°C]	-35 to +100

Further information:

Weight	55 g / pcs
GTIN	4050571480783
Customs duty number	73079910
RoHS compliant	Yes

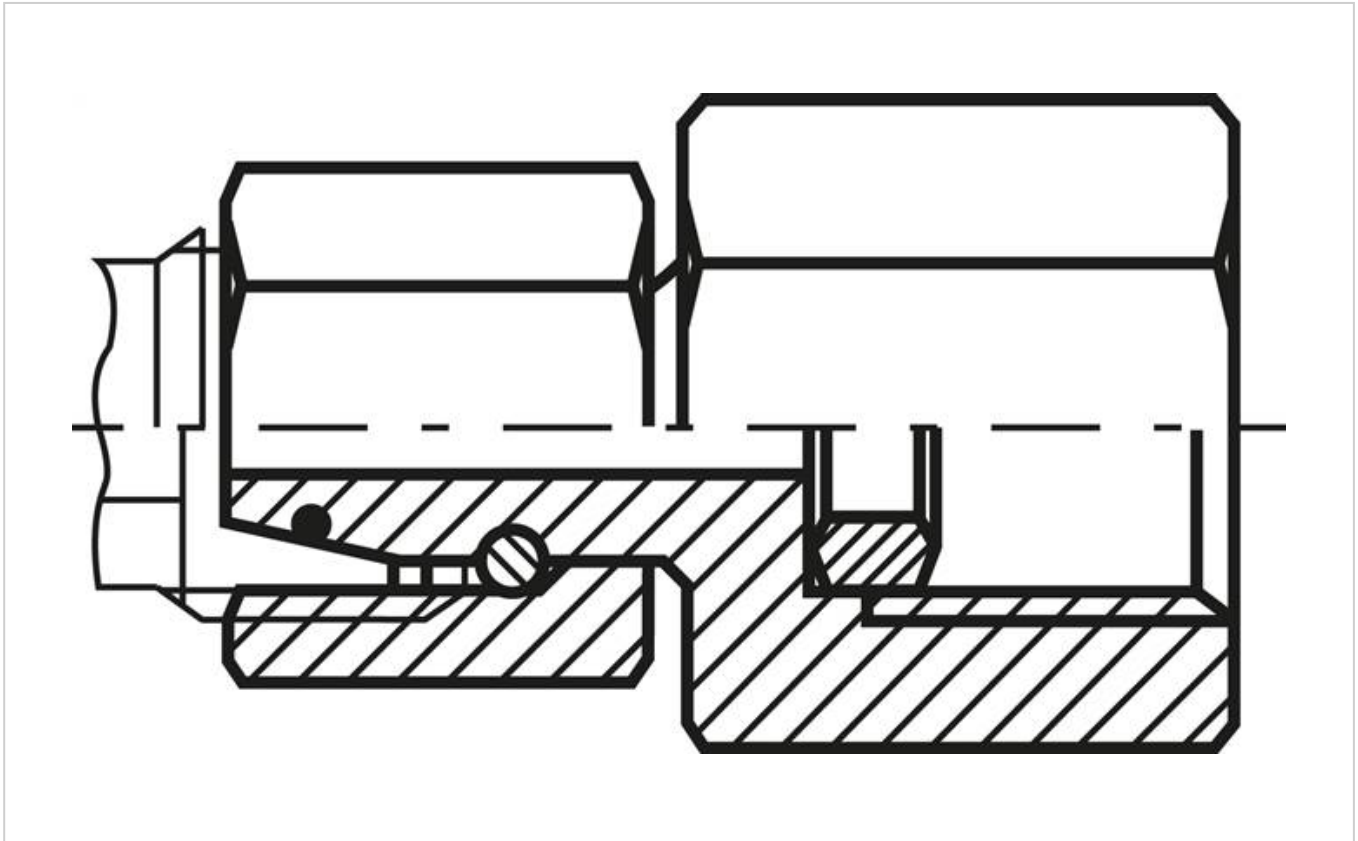
Drawing:

Drawing

More information on this item and the process for ordering it can be found in our online shop
<https://www.landefeld.com> under item number **MAVE 8 LR**.

Landefeld Druckluft und Hydraulik GmbH · Konrad-Zuse-Straße 1 · 34123 Kassel · Germany

All data are to be understood as non-binding reference values! We do not assume liability for any data selection not confirmed in writing. Unless otherwise specified, pressure values refer to liquids from Group II at +20°C.

As of: 29.06.2023