

Check Valves (CO Series)

Catalog 4130-CO
Revised, June 2001



CO Series Check Valves

Introduction

Parker CO Series Check Valves are designed for uni-directional flow control of fluids and gases in industries such as chemical processing, oil and gas production and transmission, pharmaceutical, pulp and paper, power and utilities. The CO Series Check Valve is particularly suitable for applications requiring high integrity leak rates and re-sealing capabilities.

Features

- Seal integrity across the seat and to atmosphere is tested to 4×10^{-9} std atm-cc/sec (4×10^{-10} kPa – L/sec) for the CO4L with fluorocarbon rubber seals. All other sizes and seal materials are tested to 1×10^{-5} std atm-cc/sec (1×10^{-6} kPa – L/sec).
- Special seat seal design provides a repeatable high integrity seal and accurate cracking pressures
- 100% factory tested. Cracking pressures include: 1/3, 1, 5, 10, 25, 50, 75, and 100 psi.
- Valves are available with Male and Female NPT, CPI™, A-LOK®, UltraSeal, Male and Female VacuSeal, and Tube Adapter
- Heat code traceability
- Color coded identification labels indicate seal material

Specifications

- Pressure Rating:
6000 psig (414 bar) CWP
- Temperature Rating:
Fluorocarbon Rubber
-15 °F to 400 °F (-26 °C to 204 °C)
Buna-N Rubber
-30 °F to 250 °F (-34 °C to 121 °C)
Ethylene Propylene Rubber
-70 °F to 275 °F (-57 °C to 135 °C)
Highly Fluorinated Fluorocarbon Rubber
-15 °F to 200 °F (-26 °C to 93 °C)
- Orifice: .156" to .406" (4.0mm to 10.3mm)
- C_v : .43 to 2.65

Materials of Construction

Item#	Part Description	Material
1	Cap ¹	ASTM A 276, TYPE 316
2	Seat Seal	Fluorocarbon Rubber ²
3	Body Seal	Fluorocarbon Rubber ²
4	Poppet	ASTM A 479, TYPE 316
5	Spring	316 Stainless Steel
6	Label	Aluminum
7	Body ¹	ASTM A 276, TYPE 316

¹For Female VacuSeal ports, body and cap are manufactured from ASTM A479, TYPE 316L.

²Optional seal materials are available. See How to Order section.
Lubrication: Perfluorinated Polyether

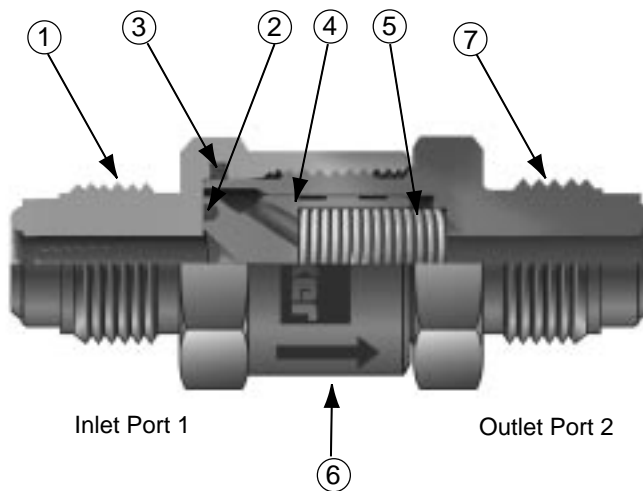

Model Shown: 4V-CO4L-5-V-SS

Flow Calculations with 1000 psig (69 bar) Inlet Pressure

Valve Series	Maximum C_v	Pressure Drop ΔP		Water @60 °F (16 °C)		Air @60 °F (16 °C)	
		psig	bar	gpm	m ³ /hr	scfm	m ³ /hr
CO4	0.62	10	0.7	2.0	0.4	61.8	104.5
		50	3.4	4.4	1.0	135.7	227.7
		100	6.9	6.2	1.4	187.5	316.7
CO6	1.85	10	0.7	5.9	1.3	184.4	311.6
		50	3.4	13.1	3.0	404.4	678.5
		100	6.9	18.5	4.2	557.9	942.3
CO8	2.65	10	0.7	8.4	1.9	264.2	446.5
		50	3.4	18.7	4.2	580.3	973.8
		100	6.9	26.5	6.0	802.3	1355.3

CO Series Check Valves

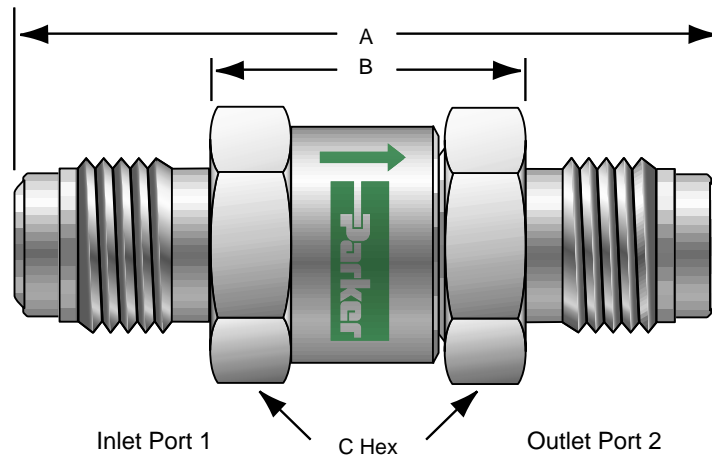

D = Hex of nuts where applicable
Model Shown: 4V-CO4L-5-KZ-SS

Label Color Cross Reference

Label Color	Seal Material
Brown	Fluorocarbon Rubber
Black	Buna-N Rubber
Purple	Ethylene Propylene Rubber
Green	All others

Testing: All valves are 100% tested for crack, re-seal, and helium leakage.

Flow Data / Dimensions

Basic Part Number	End Connections		Flow Data				Dimensions							
	(Inlet) Port 1	(Outlet) Port 2	Orifice				A†		B		C		D	
			inch	mm	C_v	$x_T \ddagger$	inch	mm	inch	mm	inch	mm	inch	mm
4A-CO4L-***-SS	1/4" A-LOK® Compression	1/4" A-LOK® Compression	.187	4.7	.62	.73	2.39	60.7	1.00	25.4	.750	19.1	.563	14.3
4F-CO4L-***-SS	1/4" Female NPT	1/4" Female NPT	.187	4.7	.62	.73	2.38	60.5	-	-	.750	19.1	-	-
4M-CO4L-***-SS	1/4" Male NPT	1/4" Male NPT	.187	4.7	.62	.73	2.09	53.1	.95	24.1	.750	19.1	-	-
4Q-CO4L-***-SS	1/4" UltraSeal	1/4" UltraSeal	.180	4.6	.58	.72	1.91	48.5	.98	24.9	.750	19.1	-	-
4TA-CO4L-***-SS	1/4" Tube Adapter	1/4" Tube Adapter	.156	4.0	.43	.62	2.35	59.7	1.07	27.2	.750	19.1	-	-
4V-CO4L-***-SS	1/4" VacuSeal	1/4" VacuSeal	.187	4.7	.62	.73	2.22	56.4	.98	24.9	.750	19.1	-	-
4V1-CO4L-***-SS	1/4" Female VacuSeal	1/4" Female VacuSeal	.182	4.6	.59	.75	2.67	67.8	.98	24.9	.750	19.1	.750	19.1
4Z-CO4L-***-SS	1/4" CPI™ Compression	1/4" CPI™ Compression	.187	4.7	.62	.73	2.39	60.7	1.00	25.4	.750	19.1	.563	14.3
M6A-CO4L-***-SS	6mm A-LOK® Compression	6mm A-LOK® Compression	.187	4.7	.62	.73	2.41	61.2	1.01	25.7	.750	19.1	.551	14.0
M6Z-CO4L-***-SS	6mm CPI™ Compression	6mm CPI™ Compression	.187	4.7	.62	.73	2.41	61.2	1.01	25.7	.750	19.1	.551	14.0
4M4A-CO4L-***-SS	1/4" Male NPT	1/4" A-LOK® Compression	.187	4.7	.62	.73	2.25	57.2	.98	24.9	.750	19.1	.563	14.3
4M4F-CO4L-***-SS	1/4" Male NPT	1/4" Female NPT	.187	4.7	.62	.73	2.26	57.4	1.69	42.9	.750	19.1	-	-
4M4Z-CO4L-***-SS	1/4" Male NPT	1/4" CPI™ Compression	.187	4.7	.62	.73	2.25	57.2	.98	24.9	.750	19.1	.563	14.3
6A-CO6L-***-SS	3/8" A-LOK® Compression	3/8" A-LOK® Compression	.281	7.1	1.70	.73	3.17	80.5	1.65	41.9	1.00	25.4	.688	17.5
6F-CO6L-***-SS	3/8" Female NPT	3/8" Female NPT	.328	8.3	1.85	.69	3.03	77.0	-	-	1.00	25.4	-	-
6M-CO6L-***-SS	3/8" Male NPT	3/8" Male NPT	.328	8.3	1.85	.69	2.78	70.6	1.64	41.7	1.00	25.4	-	-
6TA-CO6L-***-SS	3/8" Tube Adapter	3/8" Tube Adapter	.281	7.1	1.70	.73	3.09	78.5	1.65	41.9	1.00	25.4	-	-
6Z-CO6L-***-SS	3/8" CPI™ Compression	3/8" CPI™ Compression	.281	7.1	1.70	.73	3.17	80.5	1.65	41.9	1.00	25.4	.688	17.5
8V-CO6L-***-SS	1/2" VacuSeal	1/2" VacuSeal	.328	8.3	1.85	.69	3.57	90.7	2.06	52.3	1.00	25.4	-	-
8V1-CO6L-***-SS	1/2" Female VacuSeal	1/2" Female VacuSeal	.328	8.3	1.85	.69	3.57	90.7	1.65	41.9	1.00	25.4	1.062	27.0
M8A-CO6L-***-SS	8mm A-LOK® Compression	8mm A-LOK® Compression	.250	6.4	1.60	.68	3.15	80.0	1.69	42.9	1.00	25.4	.630	16.0
M8Z-CO6L-***-SS	8mm CPI™ Compression	8mm CPI™ Compression	.250	6.4	1.60	.68	3.15	80.0	1.69	42.9	1.00	25.4	.630	16.0
8A-CO8L-***-SS	1/2" A-LOK® Compression	1/2" A-LOK® Compression	.406	10.3	2.65	.75	3.37	85.6	1.63	41.4	1.25	31.8	.875	22.2
8F-CO8L-***-SS	1/2" Female NPT	1/2" Female NPT	.406	10.3	2.65	.75	3.60	91.4	-	-	1.25	31.8	-	-
8M-CO8L-***-SS	1/2" Male NPT	1/2" Male NPT	.406	10.3	2.65	.75	3.16	80.3	1.65	41.9	1.25	31.8	-	-
8Q-CO8L-***-SS	1/2" UltraSeal	1/2" UltraSeal	.375	9.5	2.55	.78	3.01	76.5	2.05	52.1	1.25	31.8	-	-
8TA-CO8L-***-SS	1/2" Tube Adapter	1/2" Tube Adapter	.375	9.5	2.55	.78	3.64	92.5	1.68	42.7	1.25	31.8	-	-
8V-CO8L-***-SS	1/2" VacuSeal	1/2" VacuSeal	.406	10.3	2.65	.75	3.56	90.4	2.05	52.1	1.25	31.8	-	-
8V1-CO8L-***-SS	1/2" Female VacuSeal	1/2" Female VacuSeal	.375	9.5	2.55	.78	3.65	92.7	1.73	43.9	1.25	31.8	1.062	27.0
8Z-CO8L-***-SS	1/2" CPI™ Compression	1/2" CPI™ Compression	.406	10.3	2.65	.75	3.37	85.6	1.63	41.4	1.25	31.8	.875	22.2
M12A-CO8L-***-SS	12mm A-LOK® Compression	12mm A-LOK® Compression	.375	9.5	2.55	.78	3.44	87.4	1.72	43.7	1.25	31.8	.866	22.0
M12Z-CO8L-***-SS	12mm CPI™ Compression	12mm CPI™ Compression	.375	9.5	2.55	.78	3.44	87.4	1.72	43.7	1.25	31.8	.866	22.0

*Cracking Pressure **Seal Designator

†For CPI™ and A-LOK®, dimensions are measured with nuts in the finger tight position.

‡Tested in accordance with ISA S75.02. Gas flow will be choked when $P_1 - P_2 / P_1 = x_T$.

CO Series Check Valves

How to Order

The correct part number is easily derived by following the circled number sequence. The six product characteristics required are coded as shown below. *Note: If both the inlet and outlet ports are the same, eliminate the outlet port designator.

Example: **4M** **4F** - **CO4L** - **1** - **V** - **SS**
 ① ② ③ ④ ⑤ ⑥
Inlet Port **Outlet Port** **Body Size** **Crack Pressure** **Seal Material** **Body Material**

Describes a CO Series Check Valve with 1/4" male NPT inlet and a 1/4" female NPT outlet, 1 psig cracking pressure, fluorocarbon rubber seals, and stainless steel body construction.

① Inlet Port	② Outlet Port	③ Body Size	④ Crack Pressure	⑤ Seat & Seal Material	⑥ Body Material
4A, 4F, 4M, 4Q, 4TA 4V, 4V1, 4Z, M6A, M6Z	4A, 4F, 4M, 4Q, 4TA 4V, 4V1, 4Z, M6A, M6Z	CO4L	1/3 psi 1 psi 5 psi	V - Fluorocarbon Rubber BN - Buna-N Rubber EPR - Ethylene Propylene Rubber KZ - Highly Fluorinated Fluorocarbon Rubber	SS - 316 Stainless Steel
6A, 6F, 6M, 6TA, 6Z, 8V, 8V1, M8A, M8Z	6A, 6F, 6M, 6TA, 6Z, 8V 8V1, M8A, M8Z	CO6L	10 psi 25 psi 50 psi		
8A, 8F, 8M, 8Q, 8TA, 8V1, 8Z, M12A, M12Z	8V, 8A, 8F, 8M, 8Q, 8TA, 8V, 8V1, 8Z, M12A, M12Z	CO8L	75 psi 100 psi		

Options

Oxygen Cleaning - Add the suffix **-C3** to the end of the part number to receive valves cleaned and assembled for oxygen service in accordance with Parker specification ES8003. **Example:** 4A-CO4L-1-BN-SS-C3

Special Cleaning - All face seal ended valves are cleaned in accordance with Parker Specification ES8001. This is an option for all valves by adding the suffix **-C1** to the end of the part number. **Example:** M6A-CO4L-10-SS-C1

Material - Contact the factory for availability of AOD/VAR stainless steel and ID Electropolish.

Available End Connections

A-Two ferrule A-LOK® compression port

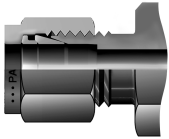

M-ANSI/ASME B1.20.1 External pipe threads



F-ANSI/ASME B1.20.1 Internal pipe threads

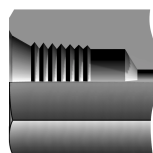

Q-UltraSeal face seal port



Z-Single ferrule CPI™ compression port

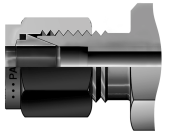

V1-Internal VacuSeal face seal port



V-VacuSeal face seal port

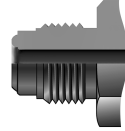

TA-Tube adapter connection

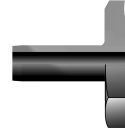

! WARNING

FAILURE, IMPROPER SELECTION OR IMPROPER USE OF THE PRODUCTS AND/OR SYSTEMS DESCRIBED HEREIN OR RELATED ITEMS CAN CAUSE DEATH, PERSONAL INJURY AND PROPERTY DAMAGE.

This document and other information from Parker Hannifin Corporation, its subsidiaries and authorized distributors provide product and/or system options for further investigation by users having technical expertise. It is important that you analyze all aspects of your application and review the information concerning the product or system in the current product catalog. Due to the variety of operating conditions and applications for these products or systems, the user, through its own analysis and testing, is solely responsible for making the final selection of the products and systems and assuring that all performance, safety and warning requirements of the application are met.

The products described herein, including without limitation, product features, specifications, designs, availability and pricing, are subject to change by Parker Hannifin Corporation and its subsidiaries at any time without notice.

Offer of Sale

The items described in this document are hereby offered for sale by Parker Hannifin Corporation, its subsidiaries or its authorized distributors. This offer and its acceptance are governed by the provisions stated in the "Offer of Sale" located in Catalog 4110-U Needle Valves (U Series).

© Copyright 2001, Parker Hannifin Corporation. All Rights Reserved.

Crack and Re-seal Performance

Check Valve Rated Crack Pressure		Minimum Acceptable Crack Pressure		Maximum Acceptable Crack Pressure		Maximum Re-seal Back Pressure	
psig	bar	psig	bar	psig	bar	psig	bar
1/3	0.02	0	0.00	1	0.07	4	0.28
1	0.07	0	0.00	3	0.21	4	0.28
5	0.34	3	0.21	8	0.55	3 BCP	0.21 BCP
10	0.69	7	0.48	13	0.90	3 BCP	0.21 BCP
25	1.72	20	1.38	30	2.07	4 BCP	0.28 BCP
50	3.45	40	2.76	60	4.14	5 BCP	0.34 BCP
75	5.17	60	4.14	90	6.21	7 BCP	0.48 BCP
100	6.89	80	5.52	120	8.27	10 BCP	0.69 BCP

BCP means "Below Cracking Pressure"

Cracking pressure is defined as the upstream pressure at which a detectable flow is measured.

Re-seal pressure is defined as the upstream pressure at which the check valve closes bubble-tight.

Example: For a valve with a spring having a rated cracking pressure of 25 psig, (1.72 bar) the actual cracking pressure ranges between 20 and 30 psig (1.38 and 2.07 bar). The re-seal pressure range would be 16 to 20 psig (1.10 to 1.38 bar). Check valves having springs with rated crack pressures of 3 psig (0.21 bar) or less may require up to 4 psig (0.28 bar) back pressure to re-seal bubble-tight.

Note: Check valves which are not actuated for a period of time may initially crack at higher than the above crack pressure ranges.

Pressure vs. Temperature

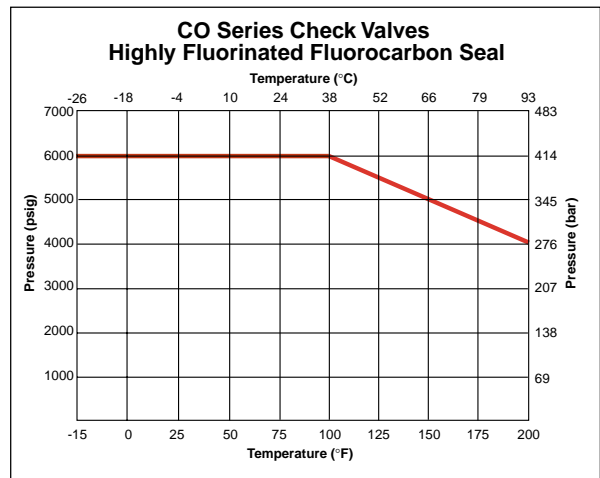
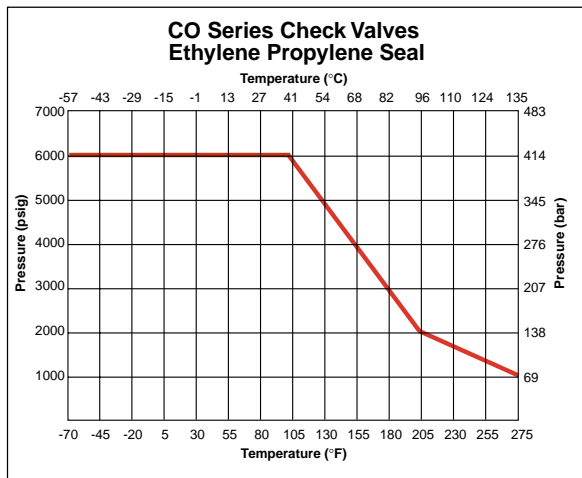
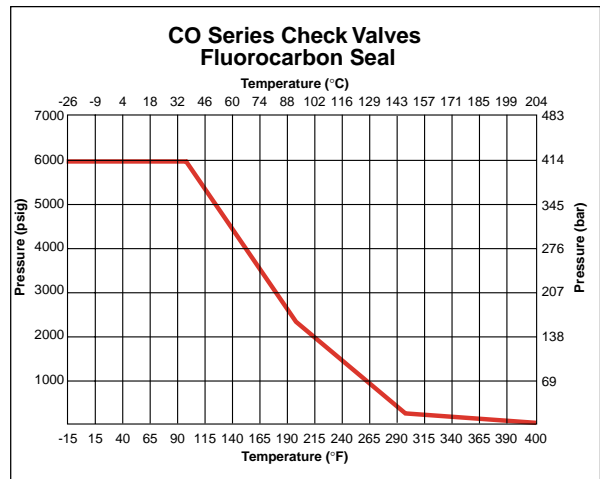
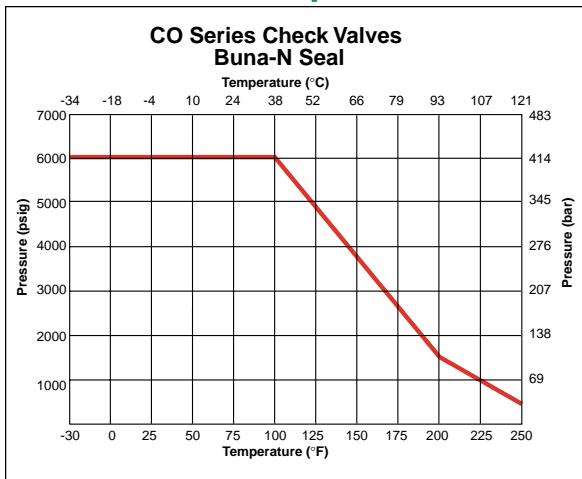

Note: To determine MPa, multiply bar by 0.1



Parker Hannifin Corporation
Instrumentation Valve Division
2651 Alabama Highway 21 North
Jacksonville, AL 36265-9681
USA
Phone: (256) 435-2130
Fax: (256) 435-7718
www.parker.com/IVD



Parker Hannifin plc
Instrumentation Products Division
Riverside Road
Pottington Business Park
Barnstaple, Devon EX31 1NP
England
Phone: +44 (0) 1271 313131
Fax: +44 (0) 1271 373636
Email: ipd@parker.com
www.parker.com/IPD

