

Amphenol SOCAPEX

SL61 & "SOCA"

Circular connectors for Showbiz & Industry



ABOUT AMPHENOL SOCAPEX



Proven excellence in interconnect solutions

Since **1947**, Amphenol Socapex has prescribed, designed and manufactured reliable and innovative interconnection solutions for **harsh environments**, specializing in standard and customized electrical and fiber optic connectors, contacts, accessories and cabling solutions. Located in the **Mont Blanc** region of France and Pune in India, Amphenol Socapex has a presence in over 100 countries around the world. Amphenol Socapex is part of the international **Amphenol Corporation**.



1000+ employees



Net Sales 2021: **92 M€**
72% Export - 28% France



Two facilities :
Thyez (France), **Pune** (India)

OUR HISTORY

1947



- Socapex creation in Suresnes, France
- 1st radio connector

1956-57



- Manufacturing unit in Cluses (74), France
- Thomson-CSF becomes primary shareholder

Early 1960's



- 1st board level connectors: HE8
- 1st "licence Bendix" manufactured connectors
- SL Series launch

1973



- New factory 13 000 m² in Thyez (74) France with 250 people

1975

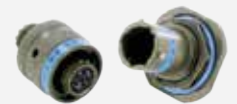

- Production of 38999 connectors

2014-2017

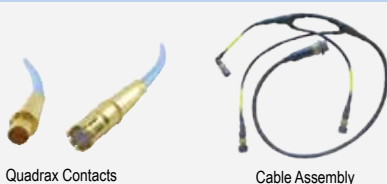

- New Cable Assembly workshop
- New Contact Manufacturing workshop

Today and tomorrow | New technologies



Miniaturization
High-speed signals
Rugged Ethernet
Fiber optics
Power
Rugged Ethernet
ROHS solutions
Power
Fiber optics
ROHS solutions
Advanced Materials (composite)
Power
Miniaturization
ROHS solutions

INTERNATIONAL EXPERTISE



Our expertise has no boundaries

Integrated Production in France & India

- **24 000 m²** manufacturing capacity on 2 sites
- Design centers in **France** and **India**
- State-of-the-art manufacturing technology



Our markets



Military

Communication Systems - Radios - C4ISR /
Ground vehicles - Vetronics / Marine / Missiles



Aviation

Commercial & military / Avionics /
Engines / Landing gear / Actuators

1986

Amphenol
Socapex

- Amphenol becomes primary shareholder

1995-96



- Expanded Beam connector CTOS launch
- Headquarters transferred to Thyex

2004



- RJ Field launch, "Award Electronica"

2005



- Opening of manufacturing site in Pune, India

2010's



- LuxBeam™ and HDAS launch

Today and tomorrow | Sustainable development



Respect for nature and the environment

Optimization of natural resources
Recycling
Waste Management
Goodwill
Optimization of natural resources
Respect for nature and the environment
Recycling

PRODUCING FASTER, SMALLER, STRONGER CONNECTORS...



Technologies & innovation

Technological Center



Engineering Laboratory for product testing and qualification, product expertise and metrology

- Mechanical and electrical skills
- RF and fiber optics expertise

High-Speed Expertise



Strong expertise in high-speed signals

- 3D EM simulation software & EM models
- Time Domain and frequency domain (VNA 20GHz, TDR and eye diagram)

Materials Expertise



Focus on materials expertise and manufacturing techniques to produce faster, smaller and stronger products

- 3D CAD mechanical software, simulation & analysis
- Disruptive metal alloys, additive manufacturing

Eco-responsibility



Sustainable environment approach, with pro-active management of regulations (REACH / RoHS / Conflict minerals...)

- New materials development, plating, and suitable processes
- Recycling and rational resources consumption

Our workshops

Our workshops located in France & India provide consistent quality adapted to your volume requirements.

Tooling : Tools for our different activities : molding, machining, assembly

Molding : Solid expertise in thermoplastic elastomer and thermoset molding

Machining : Manufacturing of cylindrical shells from 10 to 90 mm in diameter and rectangular shells

Screw Machining : Cylindrical production parts up to 10 mm in diameter

Plating : Plating with cadmium, nickel, electroless nickel, silver, black zinc nickel, gold

Assembly : Connector and harness assembly (electrical & optical)

Our certifications



Certified Management System



Certified Management System



Certified Management System



Certified Management System

Product certifications : MIL-DTL38999, EN3645, EN3155, VG

Our memberships



Member of CMG (Connecting Manufacturing Group) Consortium

DELIVERING GREAT CUSTOMER EXPERIENCE



► We have a strong reputation for helping customers solve their toughest challenges. This approach of serving your needs is ingrained in our company – from our sales team to our product development engineers.

A partner you can trust

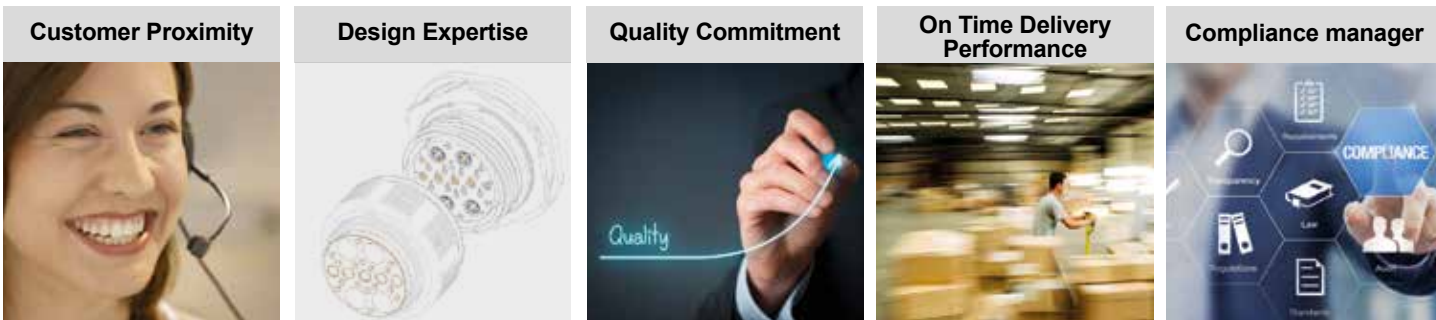

Buy our solutions

You can access our solutions through our global network of sales offices or through our distributors.

Field Sales Team :

- 12 in France
- 15 in Europe
- 100+ in North America and rest of the world.
- 5 Business Development Managers supporting local sales force Europe, North America and the rest of the world

- Technical Support & Multilingual Customer Service :**
15 people

Worldwide Distribution Network :

Including qualified distributors (QPL approved) for assembling : MIL-DTL-38999, PT/451/VG95328 & Fiber Optics connectors



SL61 & SLG419AR “SOCAPEX”

Circular Connectors for Showbiz & Industry



Description

Connectors made of aluminum alloy, with excellent reliability and robustness for In/Out applications & power supply

Main features

ROBUSTNESS AND RELIABILITY

HIGH STRENGTH-WEIGHT RATIO

UL RECOGNIZED (419AR & 37Y)

CONNECTOR BODY VERSIONS

- Plug
- Receptacle
- Receptacle with locking ring
- Inline receptacle

SPLIT BACKSHELL & MONOPIECE BACKSHELL AVAILABLE

BACKSHELL OPTIONS

- **Two-part backshells**
 - Efficient cable clamp
 - Simple wiring and maintenance
 - Straight or right angle, all sizes
- **IP67 monopiece backshell for 419AR**
 - Outdoor application

ORIGINAL MANUFACTURER OF “SOCAPEX” CONNECTORS

STAGE LIGHTNING / ENTERTAINMENT : THE “SOCA”

- 19 pins SLG 419AR for stage lightning and dimmers
- 7 pins SL 37Y (particulary for hoist motor applications)

INDUSTRIAL ARRANGEMENTS

- 4 shell sizes (#10, #20, #30, #40)
- 14 arrangements available including grounding version of 419AR (SLG 419AR)

NON CONDUCTIVE AND CONDUCTIVE SHELLS

- **ROHS versions**
 - Black non conductive coating
 - Nickel conductive plating
- **Non ROHS**
 - White conductive cadmium for connector body

Product range

<p>Receptacle</p> 	<p>mates with</p>  	<p>Plug* Right angle backshell</p> <p>Plug* Straight backshell</p>
<p>Inline receptacle* Straight backshell</p> 	<p>mates with</p>  	<p>Receptacle Locking ring</p> <p>Plug* Right angle backshell</p> <p>Plug* Straight backshell</p>

*connector body or kit (connector body + 2 parts backshell)

SL61 & SLG419AR “SOCAPEX” SERVE VARIOUS APPLICATIONS, INCLUDING:



TECHNICAL CHARACTERISTICS - SL

Circular Connectors for Showbiz & Industry

Material and platings

SHELL:

- Light aluminum alloy, molded

INSERTS:

- Molded in thermoplastic

SOLDER CUP CONTACTS

- Standard contacts with gold plated size 08, 12, 16, 20
- Socket contact:
 - Protected by a closed entry
 - To ensure an outstanding safety in use

ACCESSORIES:

- Caps: thermoplastic
- Sealing sleeve: neoprene



Technical characteristics

Working temperature: - 40°C / + 85°C

Current capability: 7,5 A, 10 A, 25 A and 50 A

Working voltage: Up to 500 V_{RMS}

UL recognition n° E160967(01) for 37Y & 419AR arrangement only

Monopiece backshell available with IP67 rating

Solder cup contacts

Contact size (AWG)	Nominal current (A)	Contact resistance	Contact cross sectional area
20	7,5	≤ 5mΩ	0,75mm ²
16	10	≤ 2mΩ	1,75mm ²
12	25	≤ 2mΩ	5,1mm ²
8	50	≤ 2mΩ	13mm ²

Platings



Black coating

Nickel

SL61 - INSERT ARRANGEMENTS

Front face of pin insert shown

Contact size (AWG)	⊖	⊕	⊖	●
Caption	20	16	12	8

Size 10

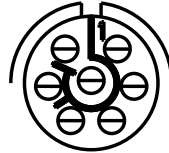
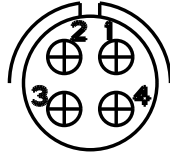
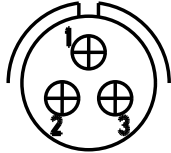

SL61	13 U	14 V	17 P
Contact size	16	16	20
Working voltage (Vrms)	280	225	150
Test voltage at sea level (Vrms)	1400	1400	1050

Size 20

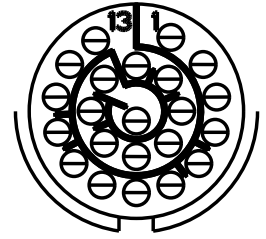
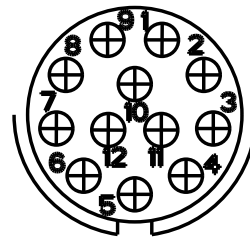
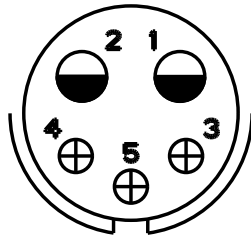
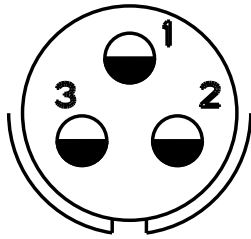

SL61	23 C	25 D	212 AF	222 P
Contact size	12	16 & 12	16	20
Working voltage (Vrms)	440	380	280	150
Test voltage at sea level (Vrms)	1400	1400	1050	1050

SL61 - INSERT ARRANGEMENTS

Front face of pin insert shown

Contact size (AWG)	⊖	⊕	◐	●
Caption	20	16	12	8

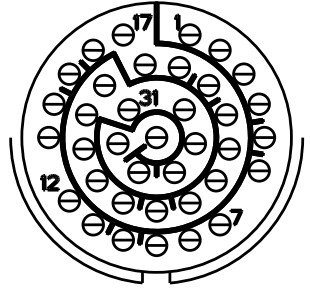
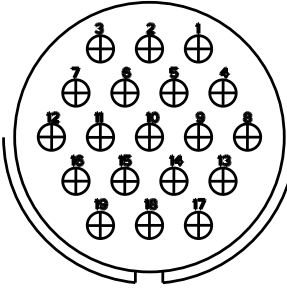
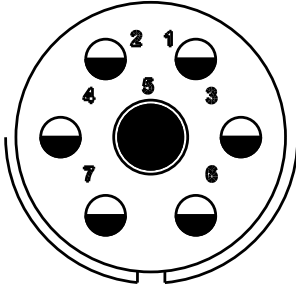
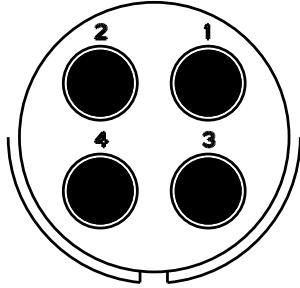

Size 30

SL61	34 H	37 Y	319 L	337 P
Contact size	8	8 & 12	16	20
Working voltage (Vrms)	500	480	400	175
Test voltage at sea level (Vrms)	1750	1750	1750	1050

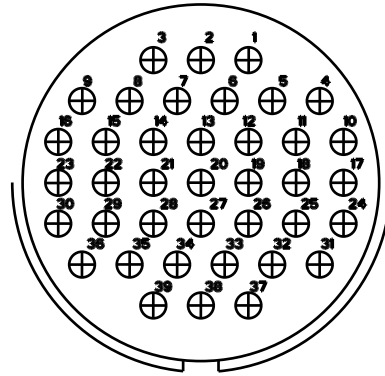
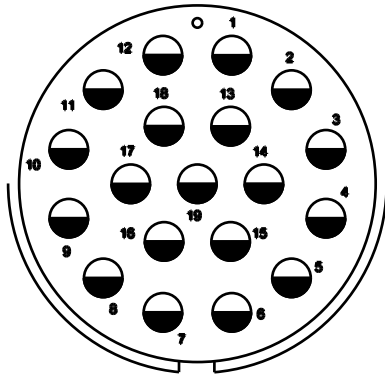

Size 40

SL61	419 AR	439 R
Contact size	12	16
Working voltage (Vrms)	400	280
Test voltage at sea level (Vrms)	1750	1750

SL SHOWBIZ “SOCA” - INSERT ARRANGEMENTS

Front face of pin insert shown

Contact size (AWG)	⊖	⊕	●	●
Caption	20	16	12	8

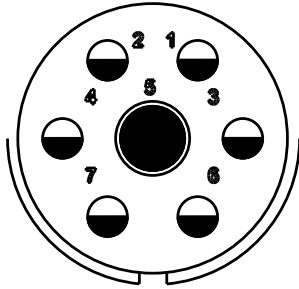

Size 30

SL61	37 Y
Contact size	8 & 12
Working voltage (Vrms)	480
Test voltage at sea level (Vrms)	1750

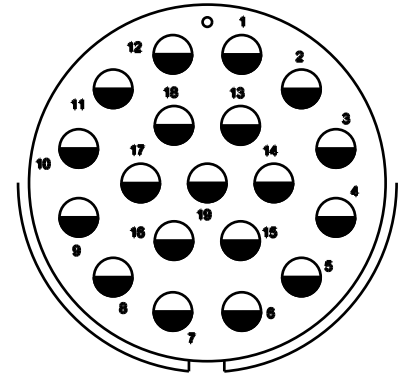

Size 40

SL61	419 AR
Contact size	12
Working voltage (Vrms)	400
Test voltage at sea level (Vrms)	1750

SLG 419AR grounding receptacle

- Derived from SL series
- Safety of the user and the equipment (ground)
- 7 socket first mate last break earth contacts (grounding function)
 - Identified by their plating
 - Improved cabling process
 - Quick visual differentiation from regular SL419AR
- 2x6 sockets, nominal current 25A each (power supplies of 6 brand-lights with independent grounding)
- Mating by reinforced screwing system
- Nominal current: 25 A
- Contact resistance < 0,002 Ohm
- Solder pot internal diameter: 2,5 mm

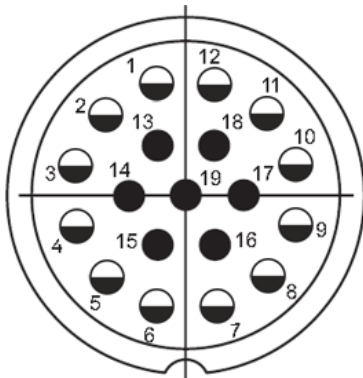

Size 40

Front face of socket insert shown

SLG	419AR
Contact size	12
Working voltage (Vrms)	400
Test voltage at sea level (Vrms)	1750

First mate last break earth contacts ●

SL61 & «SOCA»

Straight plug



Pin

Socket

How to order page 17

SL*FMD**

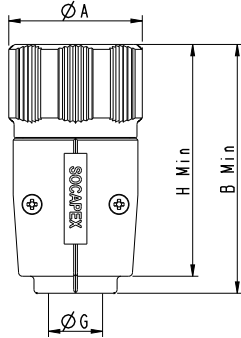

How to order page 17

SL*FFD**

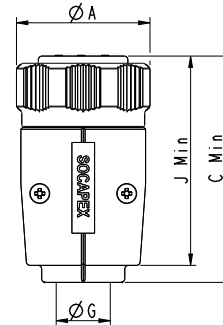

Size	B _{MIN}	C _{MIN}	ØG*			H _{MIN}	J _{MIN}	ØA ⁺⁰ _{-0.2}
10	62,20	52,85	5-7	7-9	-	54,70	48,45	27,50
20	65,90	59,70	6-8	9-11	12-14	58,40	55,20	36,50
30	87,70	80,50	10-12	13-16	17-20	81,20	74,00	51,50
40	85,90	78,70	14-18	19-23	24-30	76,40	71,20	64,50

*G: flanges equipped with different clamping pads delivered with the backshell.

Right angle plug



Pin

Socket

How to order page 17

SL*FMC**

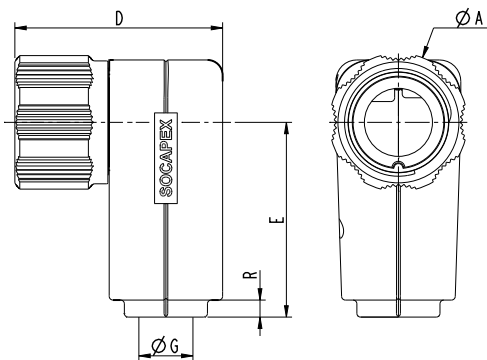

How to order page 17

SL*FFC**

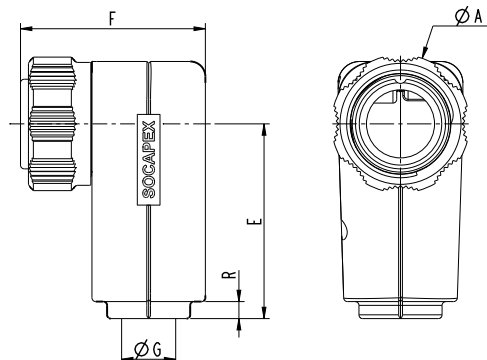

Size	D _{MIN}	E _{MIN}	ØG*			F _{MIN}	R _{MIN}	ØA ⁺⁰ _{-0.2}
10	48,10	45,50	5-7	7-9	-	38,55	4,30	27,50
20	54,90	51,50	6-8	9-11	12-14	48,70	4,30	36,50
30	67,90	55,50	10-12	13-16	17-20	60,70	6,30	51,50
40	76,00	62,50	14-18	19-23	24-30	68,70	7,30	64,50

*G: flanges equipped with different clamping pads delivered with the backshell.

All the dimensions are in mm except as otherwise specified

SL61 & "SOCA"

Receptacle



Pin

Socket

How to order page 16

SL*EM**

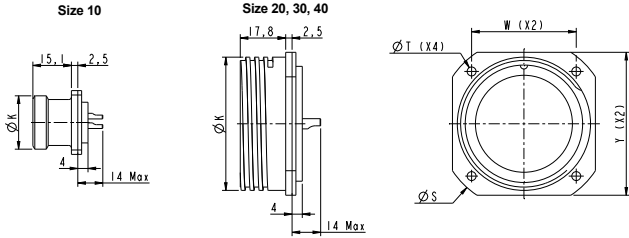

How to order page 16

SL*EF**

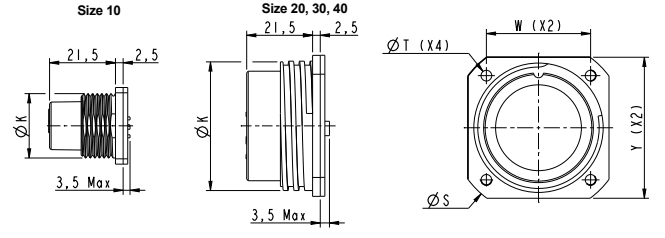

Size	ØK _{MIN}	W	Y	ØT	ØS
10	21,00	19,00	25,00	3,20	33,00
20	28,10	24,00	31,00	3,50	40,00
30	42,20	34,00	46,00	3,50	57,00
40	52,20	41,00	56,00	3,50	67,00

Receptacle with locking ring



Pin

Socket

How to order page 16

SL*EME**

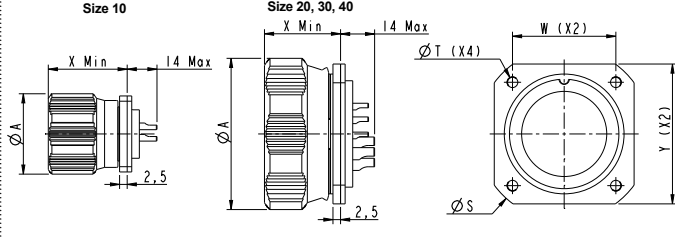

How to order page 16

SL*EFE**

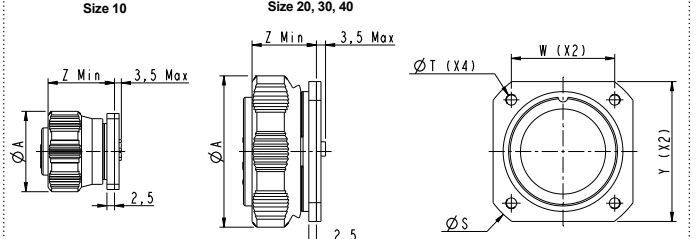

Size	ØA	W	Y	ØT	ØS	X _{Min}	Z _{Min}
10	27,50	19,00	25,00	3,20	33,00	25,90	21,20
20	36,50	24,00	31,00	3,50	40,00	24,20	20,20
30	51,50	34,00	46,00	3,50	57,00	24,40	20,20
40	64,50	41,00	56,00	3,50	67,00	29,15	22,43

Inline receptacle



Pin

Socket

How to order page 17

SL*FMDR**

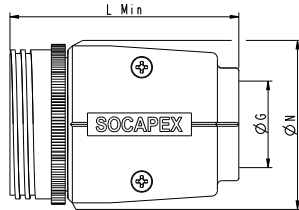

How to order page 17

SL*FFDR**

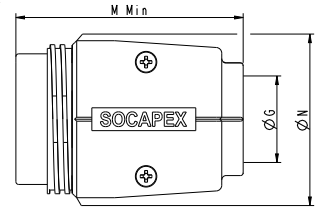

Size	L _{MIN}	M _{MIN}	ØN _{MIN}	ØG*
10	53,50	57,75	25,00	5-7
20	61,15	59,70	33,00	7-9
30	81,95	80,50	46,00	8-11
40	80,15	79,50	55,00	12-14
				10-12
				13-16
				17-20
				14-18
				19-23
				24-30

*G: flanges equipped with different clamping pads delivered with the backshell.
All the dimensions are in mm except as otherwise specified

SL61 & «SOCA» - ACCESSORIES

Two-Parts backshell



Size	Straight backshell		Right angle backshell	
	Non conductive	Conductive	Non conductive	Conductive
	Black ✓	Nickel ✓	Black ✓	Nickel ✓
10	47377N	47377NI	47381N	47381NI
20	47378N	47378NI	47382N	47382NI
30	47379N	47379NI	47383N	47383NI
40	47380N	47380NI	47384N	47384NI

✓ : RoHS compliant
 - Straight or right-angle backshells are delivered with different clamping pads

419AR monopiece backshell

- IP67, compatible with 419AR receptacle
- Exclusive gland design
 - to ensure a high mechanical retention of the cable
 - available in size 29 or 36 according to the outside diameter of the cable
- Exclusive thread design
 - to avoid accidental unscrewing of the backshell while mating / unmating
- Built-in double insulation and black non conductive plating for safety
- Contacts size 12 (AWG14-12, conductor diameter up to 2,45 mm)
- Socapex split backshell (47380N) can be used with the new plug



PG size 29

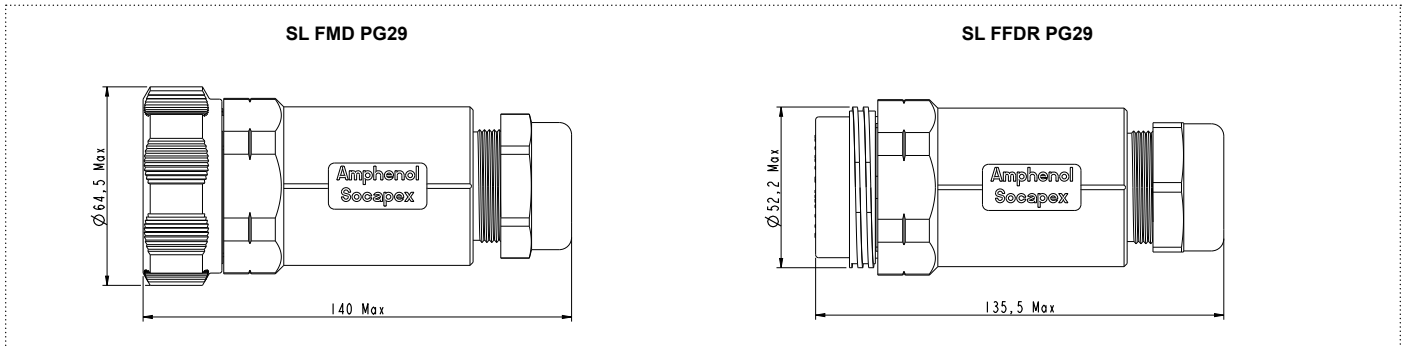

	Size 29 (cable diameter 15mm to 24mm)		
	Connector	Backshell	Set connector + backshell
Male plug	SLD BMPG 419AR	47029N	SLD FMD PG29 419AR
Female inline receptacle	SLD BFRPG 419AR		SLD FFDR PG29 419AR
Female grounded inline receptacle	SLGD BFRPG 419AR		SLGD FFDR PG29 419AR

PG size 36

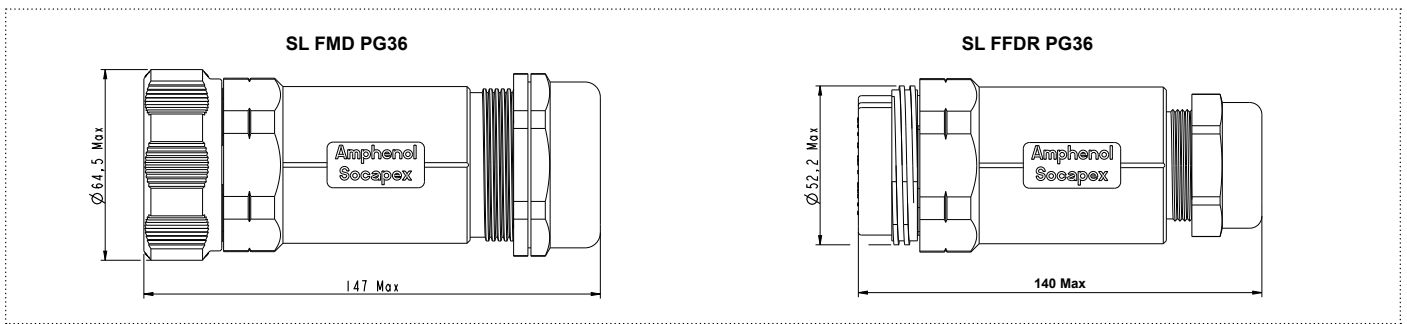

	Size 36 (cable diameter 24mm to 34mm)		
	Connector	Backshell	Set connector + backshell
Male plug	SLD BMPG 419AR	47036N	SLD FMD PG36 419AR
Female inline receptacle	SLD BFRPG 419AR		SLD FFDR PG36 419AR
Female grounded inline receptacle	SLGD BFRPG 419AR		SLGD FFDR PG36 419AR

All the dimensions are in mm except as otherwise specified

Due to technical progress, all information provided is subject to change without prior notice
 Designed by Amphenol Socapex

SL61 & “SOCA” - ACCESSORIES

All the protection caps are RoHS compliant (plastic material).

Protection cap for receptacle and inline receptacle



Pin

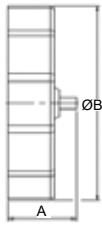

Socket

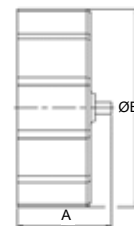

Receptacle	Inline receptacle	Size	A _{MAX}	ØB _{MAX}
SLBEM1B	SLBFMR1B	10	18,40	27,10
SLBEM2B	SLBFMR2B	20	20,20	38,00
SLBEM3B	SLBFMR3B	30	20,20	52,00
SLBEM4B	SLBFMR4B	40	20,20	63,00

Receptacle	Inline receptacle	Size	A _{MAX}	ØB _{MAX}
SLBEF1B	-	10	26,90	27,10
SLBEF2B	SLBFFR2B	20	29,20	38,00
SLBEF3B	SLBFFR3B	30	29,20	52,00
SLBEF4B	SLBFFR4B	40	29,20	63,00

Protection cap for plug and locking ring receptacle



Pin

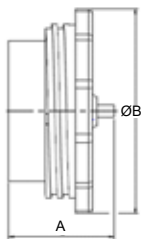

Socket

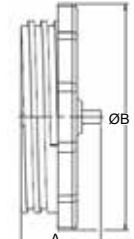

Plug	Locking ring receptacle	Size	A _{MAX}	ØB _{MAX}
SLBFM1B	-	10	30,90	21,10
SLBFM2B	-	20	31,70	38,00
SLBFM3B	BFM3B	30	31,70	52,00
SLBFM4B	BFM4B	40	31,70	63,00

Plug	Locking ring receptacle	Size	A _{MAX}	ØB _{MAX}
SLBFF1B	-	10	18,90	27,10
SLBFF2B	-	20	21,20	38,00
SLBFF3B	BFF3B	30	21,20	52,00
SLBFF4B	BFF4B	40	21,70	63,00

All the dimensions are in mm except as otherwise specified

SL61 & «SOCA» - ACCESSORIES

Sealing sleeve

Spray proofing sleeves, made of neoprene, are mounted on the rear of the plug body.

SL61

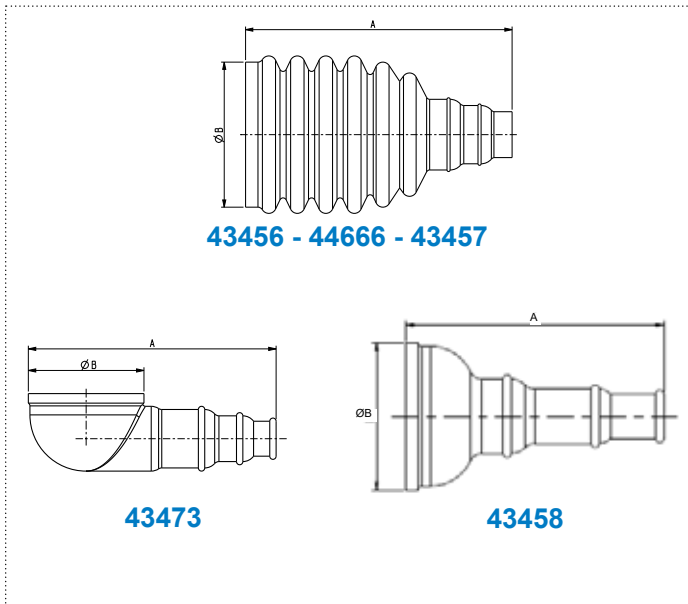

Sealing sleeve assembly instructions



If necessary, adjust the end of the sleeve to the diameter of the cable in use.
 Size 10 connectors: cut off part A for cables using the large diameter cable clamp.
 Size 20-30-40: cut off part A for cables using the middle sized clamp, and parts A and B for cables using the largest diameter cable clamp.
 The sleeve must not be gripped by the cable clamp. For small diameter cables, parts A and B should be folded back, as shown:

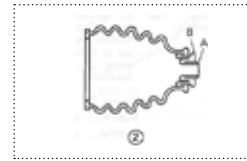

Connector	Size	A _{MAX}	ØB _{MAX}	Designation
Straight	10	32,00	18,20	43458
Right angle	10	39,00	18,20	43473
Straight or right angle	20	56,00	26,00	43456
	30	71,00	37,90	44666
	40	86,00	47,30	43457

Grounding discs for 419 AR arrangement

Pin insert: 140654-91 (front mounting)

Socket insert: 140653-00 (rear mounting)



Not available for SLG 419AR series

Adaptator for flexible conduit and PG thread

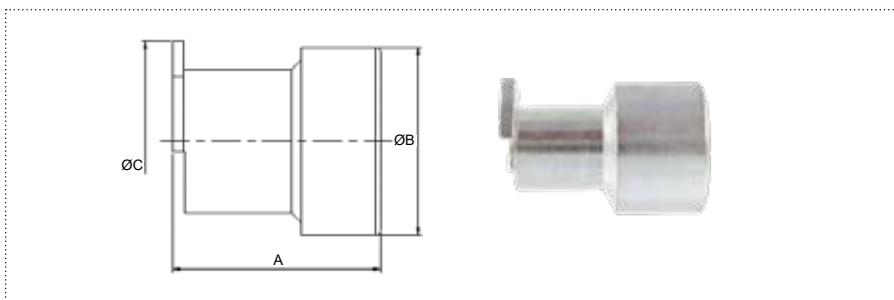

Connector size	PG size	A _{MAX}	ØB _{MAX}	ØC _{MAX}	Designation
20	9	33,50	22,20	24,00	SL RF 2 09N
	11	33,50	22,20	24,00	SL RF 2 11N
	13	38,70	30,70	32,00	SL RF 3 13N
30	16	38,70	30,70	32,00	SL RF 3 16N
	21	38,70	39,50	32,00	SL RF 3 21N
40	16	44,00	39,50	42,00	SL RF 4 16N
	21	44,00	39,50	42,00	SL RF 4 21N
	29	43,00	39,70	39,70	SL RF 4 29N

Adaptator for flexible conduit



All the dimensions are in mm except as otherwise specified

SL61 - HOW TO ORDER

Connector (without backshell)

1.	2.	3.	4.	5.
SL	D	EM	37Y	

1. Connector type

SL

2. Shell plating

D	Black coating ✓
Blank	Nickel ✓ Clear cadmium

3. Shell style & contact gender

	Pin (M)	Socket (F)
Receptacle	EM	EF
Locking ring receptacle	EME	EFE
Inline receptacle	BMR	BFR *
Plug	BM	BF

* not available for 13U, 14V & 17P
 ✓ : RoHS compliant

4. Insert arrangement

See part "Insert arrangement" page 8-10

5. Shell plating

NI	Nickel ✓
Blank	Black coating ✓ Clear cadmium

“SOCA” SLG 419AR - SHOWBIZ - HOW TO ORDER

Grounding version

1.	2.	3.	4.
SLG	D	EF	419AR

1. Connector type

SLG
 7 first mate last break earth contacts

2. Shell plating

D	Black coating ✓
Blank	Clear cadmium

✓ : RoHS compliant

3. Shell style & contact gender

EF	Socket panel mount receptacle
FFDR	Socket inline receptacle

4. Insert arrangement

419AR

SL61 - HOW TO ORDER

Connector + 2-parts backshell

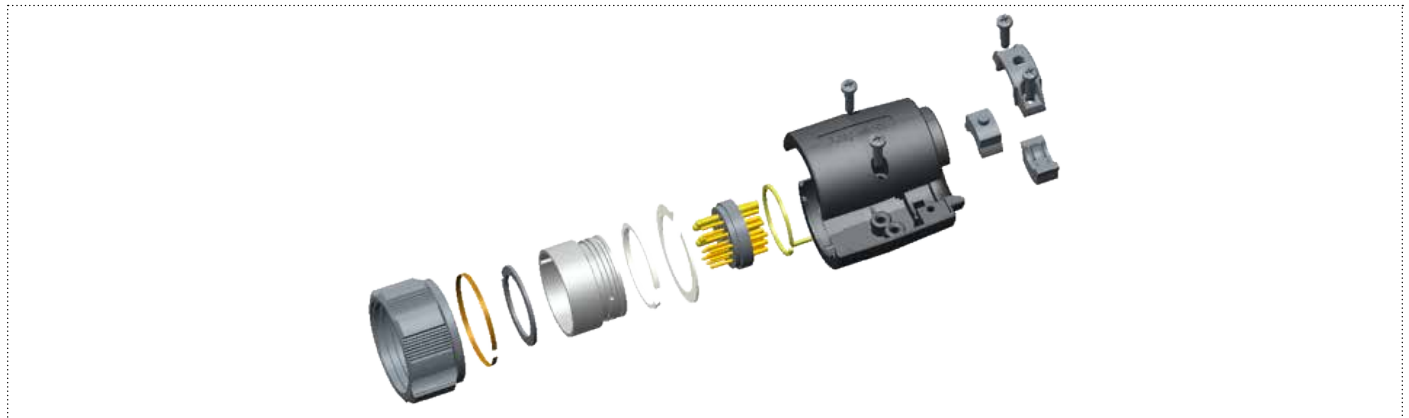

1.	2.	3.	4.	5.	6.	7.
SL		F	M	D	319L	NI

1. Connector type

SL

2. Shell plating

D	Black coating ✓
Blank	Nickel ✓ Clear cadmium**

3. Kit, mandatory digit

F

4. Contact gender

M	Pin
F	Socket

* not available in female version for 13U, 14V and 17P arrangement

** delivered with black backshell

✓ : RoHS compliant

5. Kit composition

D	Plug + straight backshell
DR	Inline receptacle + straight backshell *
C	Plug + right angle backshell

6. Insert arrangement

See part "insert arrangement" page 8-10

7. Shell plating

NI	Nickel ✓
Blank	Black coating ✓ Clear cadmium**

Kit details



A kit is made of :

- SL connector
- 2-parts backshell (upper backshell & lower backshell) + 2 fixing screws
- 2 or 3 plastic cable clamps (2 for size 10, 3 for sizes 20, 30, 40)
- 1 cable fixing bridge + 2 bridge fixing screws

SL61 & «SOCA» - WEIGHTS

In grams	Plug: body + backshell				Plug: body		Receptacle		Inline receptacle : body + backshell		Inline receptacle: body		Locking ring receptacle	
	Insert	SL F FD	SL F MD	SL F FC	SL F MC	SL B F	SL B M	SLE F	SLE M	SL FF DR	SL FM DR	SL BF R	SL BM R	SLE FE
13U	30	33	42	45	15	23	15	12	-	28	12	12	22	22
14V	30	34	42	46	16	24	15	12	-	29	12	12	22	22
17P	32	35	44	47	18	25	17	13	31	30	14	13	24	23
23C	62	65	80	83	35	41	26	24	57	58	24	15	37	36
25D	32	35	80	83	35	41	26	24	57	58	24	15	37	36
212AF	62	65	80	83	36	42	27	24	57	58	24	16	38	36
222P	67	68	85	86	41	46	32	27	62	61	29	20	43	39
34H	136	145	165	174	74	87	67	63	122	125	56	41	81	78
37Y	135	142	164	171	72	82	65	58	121	122	54	36	79	73
319L	133	135	162	164	69	77	64	53	119	115	52	31	78	68
337P	143	143	172	172	78	84	74	60	129	123	61	38	88	75
419AR	209	212	238	241	113	133	101	85	191	194	92	87	124	116
439R	202	203	231	232	106	123	96	77	183	185	85	78	119	108
G419AR							99		186		88			

In grams	Protection cap			
	Size	SLB FF B FF *	SLB FM B FM *	SLB EF SLB FFR
10	11	12	14	11
20	14	18	22	15
30	19	27	31	21
40	23	34	39	26

* B FF & B FM caps in size 10 & 20 are not available

ABOUT AMPHENOL

Founded in 1932, Amphenol is one of the largest manufacturers of interconnect products in the world. The company designs, manufactures, and markets electrical, electronic, and fiber optic connectors, interconnect systems, and coaxial and specialty cables.

Amphenol has a diversified presence as a leader in high growth areas of the interconnect industry and provides solutions for customers in the automotive, broadband, industrial, information technology and data communications, military and aerospace, mobile devices, and mobile networks markets.

More info on www.amphenol.com

Amphenol
ENABLING THE ELECTRONICS REVOLUTION

Amphenol Military & Aerospace Operations (AMAO) has the largest and broadest selection of interconnect products in the military and aerospace markets.

More info on www.amphenolmao.com

Amphenol
MILITARY & AEROSPACE

Europe

FRANCE	Amphenol AIR LB	2 rue Clément Ader, ZAC de W6 - 08110 Carignan	+33 3 29 22 74 00
FRANCE	Amphenol 06758	Z.I. des Cazes - BP243 - 12452 Saint-Aubiquy Cedex	+33 5 00 00 11 00
GERMANY	Amphenol AIR LB 045H	Am Kleinbahnhof 4 - 85740 Gesslouis	+49 0901 001 90
ITALY	Amphenol EUROPEAN SALES OPERATIONS	Via Barbalana n.5 - 20020 Linate - Milano	+39 024 254 21 1
UNITED KINGDOM	Amphenol 040780	Unit 1-3, Hedging Lane Industrial Estate, Doot Hill - Tamworth, B77 5HH	+44 1827 296 300
UNITED KINGDOM	Amphenol 0408 047800	Prospect House, Taylor Business Park, Riley, Westington, WA3 6HP	+44 1848 000 200
UNITED KINGDOM	Amphenol LTD	Thanel Way, Whitstable - KENT, CT53JF	+44 1827 776 300
UNITED KINGDOM	Amphenol 040780	St Augustines Business Park, Swalecliffe Whitstable - Kent CT5 2QJ	+44 1827 796 790

North America

CANADA	Amphenol CANADA	655 Milner Avenue - Toronto, Ontario	+1 416 264 0007
USA	Amphenol AEROSPACE OPERATIONS	42-80 Delaware Street - Sidney, NY 13638	+1 608 670 0544
USA	Amphenol BORNH TECHNOLOGIES	4511 East Paris Ave - Grand Rapids, MI 49512	+1 609 554 0000
USA	Amphenol PDI	1300 Central Expressway N, Suite 100 - Allen, TX 75013	+1 214 547 2000
USA	Amphenol BRITISH ENTERPRISES	6500 East Coary Drive - Cottonwood, AZ 85320	+1 602 664 0000
USA	Amphenol MEDICAL TECHNOLOGIES	55 Sunnyside Avenue - Stamford, CT 06902	+1 203 627 7000
USA	Amphenol PDI	72 Cherry Hill Drive - Beverly, MA 01915	+1 678 624 1400
USA	Amphenol PRINTED CIRCUIT	Board Technology, 91 Northeastern Boulevard - Nashua, NH 03082	+1 603 834 0500
USA	Amphenol 04 04080478	2400 Centipark West Drive - West Palm Beach, FL	+1 561 640 1000
USA	Amphenol TERRY ELECTRONICS	358 Hall Avenue - Wallingford, CT 06492	+1 800 657 8020

Asia

CHINA	Amphenol PDI-00	Building 21, Miaoqing Industrial Zone, Shiyin Street, BaoAn District, Shenzhen 518108	+86 755 3176 4000/8000
INDIA	Amphenol 040808080808 (MBA)	105 Bhosari Industrial Area - Pune 411 026	+91 80 30100000
JAPAN	Amphenol JAPAN	475-1, Deba, Riso-City - Shiga 520 3041	+81 77 390 8071
KOREA	Amphenol 04080808	558 Seonghee-Dong SoSe-Gu, Bucheon-city, Kyunggi-Do - 420-130	+81 80 010 30000000
SINGAPORE	Amphenol 0407 0408	287F, Railway Plaza, 39 Chatham Road South, Tsim Sha Tsui, Kowloon, Hong Kong	+65 6864 8126

Other Areas

AFRICA	Amphenol AFRICA	30 Impela Rd - Sandton 2146	+27 06 410 3179
ARGENTINA	Amphenol ARGENTINA	Av. Callao 550 2do piso Oficina B "Plaza" C1023 - AAP Buenos Aires	+54 11 4043 0000
AUSTRALIA	Amphenol AUSTRALIA PTY	2 Fyneways Blvd., Keysborough - Melbourne - Victoria 3173	+61 3 9930 2000
BRAZIL	Amphenol DO BRASIL	Rua Diogo Moreira, 132, 2o andar, rooms 2001-2-3	+55 11 6043 9000
ISRAEL	Amphenol 0407 0408	3 Hagevish Street, K R-Baron Bldg, East Industrial Zone - Kfar-Sava, 44102	+972 9 784 4180
MEXICO	Amphenol 0407 0408	Carretera Internacional Km 6.5, Cd. Parque Industrial, Nogales, Sonora, C.R. 84004	+52 661 311 100
NEW ZEALAND	Amphenol PHYTEK	Level 4, 2 Kingdon Street, Newmarket, Auckland 1023	+64 9 000 2000
RUSSIA	Amphenol RUSSIA	Yaroslavl'skaya Street 8 - 129184 Moscow	+7 495 307 0001
TURKEY	Amphenol TURKEY	Sen Plaza 15 Kat: 15 Maslak Mah. 58km Sok. No.5 - Beşiktaş/Istanbul, 34360	+90 212 347 98 49

Amphenol SOCAPEX



Amphenol Socapex

948, promenade de l'Arve BP29
74311 Thyez Cedex - France
Phone: +33 (0)4 50 89 28 00
contact@amphenol-socapex.fr
www.amphenol-socapex.com



For Technical Support

+33 (0)4 50 89 28 49
technicalsupport@amphenol-socapex.fr
www.amphenol-socapex.com/technical_support



To buy our products

+33 (0)4 50 90 28 00
contact@amphenol-socapex.fr
www.amphenol-socapex.com/amphenol/sales
Request a quote online at www.amphenol-socapex.com/quotation_request



Documentation

www.amphenol-socapex.com/documentation
To order a paper version of our catalogs, send an e-mail to communication@amphenol-socapex.fr



www.amphenol-socapex.com

Follow Amphenol Socapex on social media :



This catalog uses paper from managed forests, PEFC & FSC labels, and is printed by a printer certified "Imprim'Vert"

We reserve the right to modify our products in any way we deem necessary.
Any duplication is prohibited, unless approved in writing.

Designed by Amphenol Socapex
DOC-001018-ANG - January 2022