

V8 Series Dimensions / Flow Data

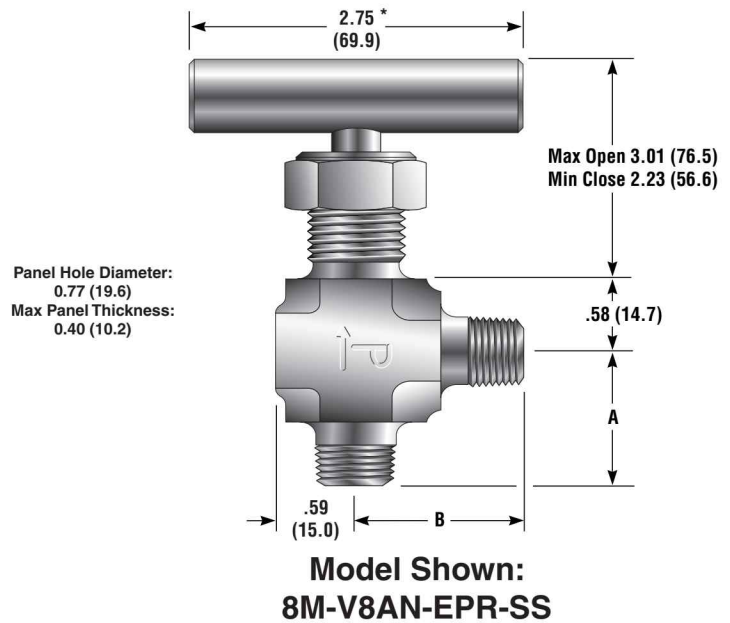
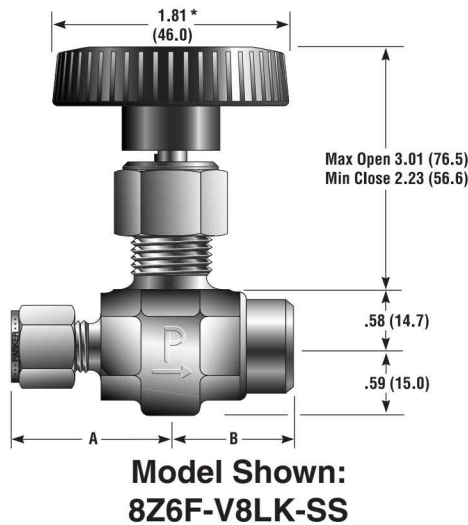

* Note: Handles for N or R Stem V8 Series Valves are a T-bar
() Denotes dimensions in millimeters

Basic Part Number		End Connections		Stem Type	Flow Data				Dimensions					
Inline	Angle	Inlet (Port 1)	Outlet (Port 2)		Orifice		Inline		Angle		A†		B†	
					Inch	mm	C_V	X_T^*	C_V	X_T^*	Inch	mm	Inch	mm
6F-V8LR	6F-V8AR	3/8" Female NPT		Blunt	0.312	7.9	1.23	0.87	1.66	0.72	1.34	34.0	1.34	34.0
6F-V8LN	6F-V8AN			Needle			1.05	0.83	1.28	0.80				
6F-V8LK	6F-V8AK			PCTFE			1.29	0.91	1.90	0.76				
8A-V8LR	8A-V8AR	1/2" Compression A-LOK®		Blunt	0.312	7.9	1.23	0.87	1.66	0.72	1.53	38.9	1.53	38.9
8A-V8LN	8A-V8AN			Needle			1.05	0.83	1.28	0.80				
8A-V8LK	8A-V8AK			PCTFE			1.29	0.91	1.90	0.76				
8M-V8LR	8M-V8AR	1/2" Male NPT		Blunt	0.312	7.9	1.23	0.87	1.66	0.72	1.34	34.0	1.34	34.0
8M-V8LN	8M-V8AN			Needle			1.05	0.83	1.28	0.80				
8M-V8LK	8M-V8AK			PCTFE			1.29	0.91	1.90	0.76				
8Z-V8LR	8Z-V8AR	1/2" Compression CPI™		Blunt	0.312	7.9	1.23	0.87	1.66	0.72	1.53	38.9	1.53	38.9
8Z-V8LN	8Z-V8AN			Needle			1.05	0.83	1.28	0.80				
8Z-V8LK	8Z-V8AK			PCTFE			1.29	0.91	1.90	0.76				
M10A-V8LR	M10A-V8AR	10mm Compression A-LOK®		Blunt	0.281	7.1	1.13	0.79	1.52	0.66	1.42	36.1	1.42	36.1
M10A-V8LN	M10A-V8AN			Needle			0.97	0.78	1.18	0.75				
M10A-V8LK	M10A-V8AK			PCTFE			1.18	0.80	1.69	0.66				
M10Z-V8LR	M10Z-V8AR	10mm Compression CPI™		Blunt	0.281	7.1	1.13	0.79	1.52	0.66	1.42	36.1	1.42	36.1
M10Z-V8LN	M10Z-V8AN			Needle			0.97	0.78	1.18	0.75				
M10Z-V8LK	M10Z-V8AK			PCTFE			1.18	0.80	1.69	0.66				
M12A-V8LR	M12A-V8AR	12mm Compression A-LOK®		Blunt	0.281	7.1	1.13	0.79	1.52	0.66	1.51	38.4	1.51	38.4
M12A-V8LN	M12A-V8AN			Needle			0.97	0.78	1.18	0.75				
M12A-V8LK	M12A-V8AK			PCTFE			1.18	0.80	1.69	0.66				
M12Z-V8LR	M12Z-V8AR	12mm Compression CPI™		Blunt	0.281	7.1	1.13	0.79	1.52	0.66	1.51	38.4	1.51	38.4
M12Z-V8LN	M12Z-V8AN			Needle			0.97	0.78	1.18	0.75				
M12Z-V8LK	M12Z-V8AK			PCTFE			1.18	0.80	1.69	0.66				

* Tested in accordance with ISA S75.02. Gas flow will be choked when $P_1 - P_2 / P_1 = X_T$.
† For CPI™ and A-LOK®, dimensions are measured with nuts in the finger tight position.

Dimensions in inches/millimeters are for reference only, subject to change.