

Introduction

Parker PR Series Plug Valves provide positive leak tight shut-off, high flow capacity, and quick quarter-turn operation in a compact attractive package. The patented blow-out resistant seat design offers reliable sealing technology at all operating pressures. In addition to on-off actuation, the plug design allows forward flow throttling. A selection of valve seat and seal materials may be chosen for media compatibility and performance over a broad range of temperatures. The pressure balanced atmospheric seals are backed by PTFE rings to enhance their performance and increase cycle life.

Features

PR

- ▶ Patented blow-out resistant seat design
- ▶ Pressures up to 3,000 psig (207 bar) CWP
- ▶ Quarter-turn operation
- ▶ Reliable simple design
- ▶ Straight-through flow
- ▶ Stainless steel and brass construction
- ▶ Nitrile, ethylene propylene, fluorocarbon, and highly fluorinated fluorocarbon rubber seats and seals
- ▶ PTFE back-up rings on atmospheric seals
- ▶ Low operating torque
- ▶ Minimum pressure drop
- ▶ Throttling capability
- ▶ Positive handle stops
- ▶ Color coded fracture resistant nylon handles with directional flow indication
- ▶ Easy to service
- ▶ 100% factory tested
- ▶ Options include lock-out devices, downstream venting, and both stainless steel and T-bar handles

Specifications

Pressure Ratings:

Normal Flow Direction: 3000 psig (207 bar) CWP

Reverse Flow Direction: 150 psig (10 bar)

Downstream Vent Option: 150 psig (10 bar)

Open



Closed

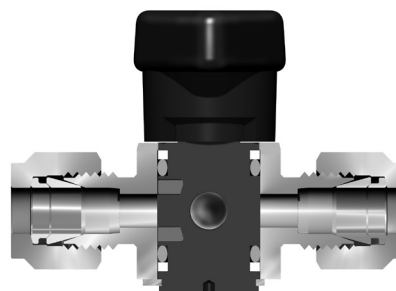

Model Shown: 4A-PR4-VT-SS

U.S. Patent 5,234,193

Materials of Construction

Item #	Part Description	Stainless Steel	Brass
1	Body	ASTM A 479 Type 316	ASTM B 16 Alloy C36000
2	Plug*	ASTM A 479 Type 316	ASTM B 16 Alloy C36000
3	Seat**	Fluorocarbon Rubber	
4	O-Ring Seals**	Fluorocarbon Rubber	
5	Back-up Rings	PTFE	
6	Handle	Nylon 6/6	
7	Handle Pin	316 Stainless Steel	
8	Body Pin	316 Stainless Steel (not shown)	
9	Retaining Ring	316 Stainless Steel	

* Plugs are PTFE color coated – Stainless steel plugs are black; Brass plugs are brown.

** Optional Seat and O-ring seal materials are available.
Lubrication: Perfluorinated polyether

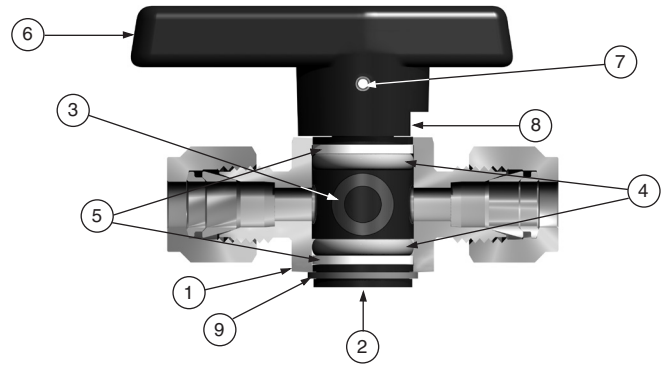

Model Shown: 4A-PR4-VT-SS



Pressure vs. Temperature

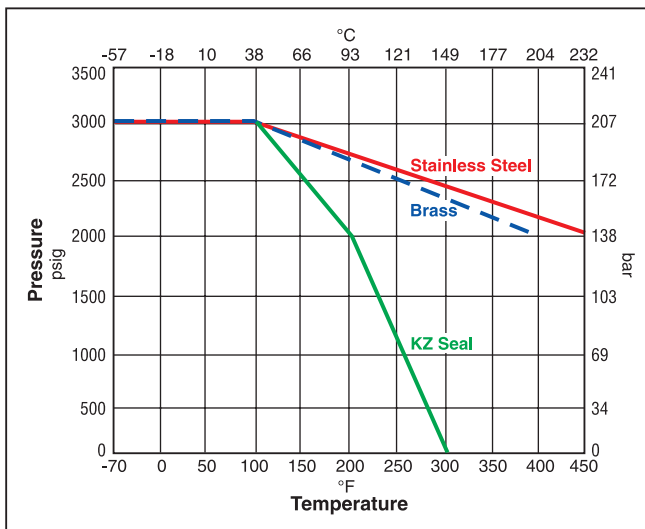

Note: This Pressure versus Temperature chart reflects the maximum temperature range of indicated body materials. The temperature rating of the elastomer seals become the limiting factor on temperature range.

Temperature Ratings

Material	Temperature Rating
Nitrile Rubber	-30°F to 225°F (-34°C to 107°C)
Fluorocarbon Rubber	-10°F to 450°F (-23°C to 232°C)
Highly Fluorinated Fluorocarbon Rubber	-10°F to 300°F (-23°C to 149°C)
Ethylene Propylene Rubber	-70°F to 275°F (-57°C to 135°C)

Note: To determine MPa, multiply bar by 0.1

Flow Calculations with 1000 psig (69 bar) Inlet Pressure

Valve Series	Max. Cv	Pressure Drop ΔP		Water @ 60°F (16°C)		Air @ 60°F (16°C)	
		psig	bar	gpm	m³/hr	scfm	m³/hr
PR4	1.24	10	0.7	3.9	0.9	123.1	209.6
		50	3.4	8.8	2.0	265.9	446.3
		100	6.9	12.4	2.8	359.6	607.0
PR6	3.19	10	0.7	10.1	2.3	315.7	533.5
		50	3.4	22.6	5.1	672.3	1128.2
		100	6.9	31.9	7.2	891.6	1504.1



Kits

Plug Kits – Specify the combination of valve series, seal material, plug material, and handle color (if applicable).

Example: KIT-PR4-VT-SS-R. This kit consists of a PR4 stainless steel plug with fluorocarbon rubber seat and seal elastomers, PTFE back-up rings, red handle, and handle pin.

Seal Kits – Specify the combination of valve series and seal material.

Example: KIT-PR4-BN. This kit consists of a PR4 Nitrile rubber seat and seal elastomers and PTFE back-up rings.

Flow Data / Dimensions

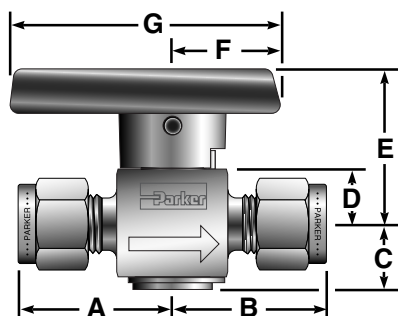

Model Shown: 4A-PR4-VT-B

Port Size	Basic Part #	Flow Data				End Connections		Dimensions Inches (mm)					
		Orifice		Cv	X _T *	Port 1	Port 2	A †	B †	C	D	E	F
Inch	mm												
2F	PR4	0.193	4.9	1.24	0.39	1/8" Female NPT	0.89 (22.6)	0.89 (22.6)	0.46 (11.7)	0.38 (9.7)	1.07 (27.2)	0.75 (19.1)	1.88 (47.8)
2M		0.172	4.4	1.02	0.39	1/8" Male NPT	0.77 (19.6)	0.77 (19.6)					
2A		0.093	2.4	0.22	0.48	1/8" A-LOK®	1.00 (25.4)	1.00 (25.4)					
2Z						1/8" CPI™	1.00 (25.4)	1.00 (25.4)					
4F		0.193	4.9	1.24	0.39	1/4" Female NPT	1.05 (26.7)	1.05 (26.7)					
4M		0.193	4.9	1.24	0.39	1/4" Male NPT	0.96 (24.4)	0.96 (24.4)					
4A		0.187	4.7	1.18	0.41	1/4" A-LOK®	1.09 (27.7)	1.09 (27.7)					
4Z						1/4" CPI™	1.09 (27.7)	1.09 (27.7)					
4V		0.187	4.7	1.18	0.41	1/4" VacuSeal	1.02 (25.9)	1.02 (25.9)					
6A		0.193	4.9	1.24	0.39	3/8" A-LOK®	1.14 (29.0)	1.14 (29.0)					
6Z						3/8" CPI™	1.14 (29.0)	1.14 (29.0)					
M6A		0.188	4.8	1.18	0.41	6mm A-LOK®	1.08 (27.4)	1.08 (27.4)					
M6Z						6mm CPI™	1.08 (27.4)	1.08 (27.4)					
4F	PR6	0.281	7.1	3.19	0.28	1/4" Female NPT	1.19 (30.2)	1.19 (30.2)	0.67 (17.0)	0.56 (14.2)	1.49 (37.8)	0.99 (25.1)	2.40 (61.0)
6A		0.281	7.1	3.19	0.28	3/8" A-LOK®	1.33 (33.8)	1.33 (33.8)					
6Z						3/8" CPI™	1.33 (33.8)	1.33 (33.8)					
8F		0.281	7.1	3.19	0.28	1/2" Female NPT	1.44 (36.6)	1.44 (36.6)					
8M		0.281	7.1	3.19	0.28	1/2" Male NPT	1.32 (33.5)	1.32 (33.5)					
8A		0.281	7.1	3.19	0.28	1/2" A-LOK®	1.44 (36.6)	1.44 (36.6)					
8Z						1/2" CPI™	1.44 (36.6)	1.44 (36.6)					
M8A		0.250	6.4	2.84	0.29	8mm A-LOK®	1.30 (33.0)	1.30 (33.0)					
M8Z						8mm CPI™	1.30 (33.0)	1.30 (33.0)					
M10A		0.281	7.1	3.19	0.28	10mm A-LOK®	1.34 (34.0)	1.34 (34.0)					
M10Z						10mm CPI™	1.34 (34.0)	1.34 (34.0)					
M12A	0.281	7.1	3.19	0.28	12mm A-LOK®	1.47 (37.3)	1.47 (37.3)						
M12Z					12mm CPI™	1.47 (37.3)	1.47 (37.3)						

* Tested in accordance with ISA S75.02. Gas flow will be choked when $P_1 - P_2 / P_1 = X_T$.

† For CPI™ and A-LOK®, dimensions are measured with nuts in the finger tight position.

Dimensions in inches/millimeters are for reference only, subject to change.

How to Order

The correct part number is easily derived from the following example and ordering chart. The six product characteristics required are coded as shown in the chart.

* **Note:** If the inlet and outlet ports are the same, eliminate the outlet port designator.

The following example describes a PR Series rotary plug valve equipped with 1/4" CPI™ compression inlet and outlet ports, Nitrile seals, PTFE back-up rings, and stainless steel construction.

Example:

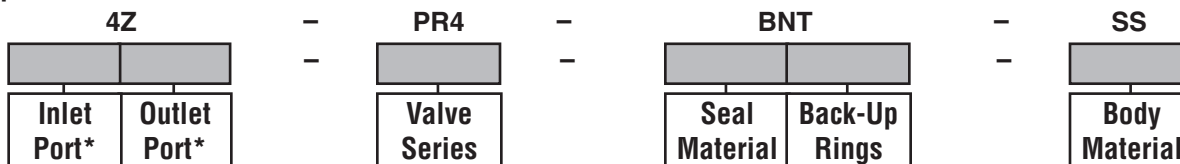

Inlet and Outlet Ports*		Valve Series	Seal Material		Back-Up Rings	Body Material					
2A	1/8" A-LOK®	PR4	V	Fluorocarbon Rubber	T	PTFE	SS	Stainless Steel			
2Z	1/8" CPI™		KZ	Highly Fluorinated Fluorocarbon Rubber			B	Brass			
2F	1/8" Female NPT		M6A	6mm A-LOK®			EPR	Ethylene Propylene Rubber			
2M	1/8" Male NPT		M6Z	6mm CPI™			BN	Nitrile Rubber			
4A	1/4" A-LOK®		PR6	V			Fluorocarbon Rubber	T	PTFE	SS	Stainless Steel
4Z	1/4" CPI™			KZ			Highly Fluorinated Fluorocarbon Rubber			B	Brass
4F	1/4" Female NPT			M8A			8mm A-LOK®			EPR	Ethylene Propylene Rubber
4M	1/4" Male NPT			M8Z			8mm CPI™			BN	Nitrile Rubber
4V	1/4" VacuSeal			M10A			10mm A-LOK®				
4F	1/4" Female NPT			M10Z			10mm CPI™				
6A	3/8" A-LOK®	M12A		12mm A-LOK®							
6Z	3/8" CPI™	M12Z		12mm CPI™							
8A	1/2" A-LOK®										
8Z	1/2" CPI™										
8F	1/2" Female NPT										
8M	1/2" Male NPT										

* If the inlet and outlet ports are the same, eliminate the outlet port designator.

Options

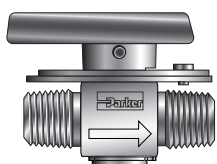

Lock-Out Device

Used to lock the handle from accidental rotation in either the opened or closed position. To order the device separately, specify **LD-PR4** or **LD-PR6**.

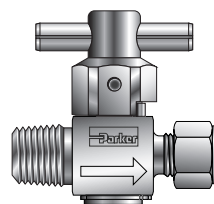

T-Bar Handle

An all metal bar stock design for higher strength and durability. Consists of a stainless steel pin and aluminum adapter. To order, add the suffix **-T** to the end of the part number.

Example and model shown: 4M4A-PR4-EPRT-SS-T.

Downstream Venting – As the valve is positioned from opened to closed, downstream pressure is released to atmosphere through a vent hole in the body and plug. The maximum recommended operating pressure for this option is 150 psig (10 bar). To order, insert **V** after PR in the model number. **Example:** 4A-PRV4-VT-B

Colored Handles – Black is the standard color. Add the designator corresponding to the correct handle color as a suffix to the part number: **B** – blue, **G** – green, **R** – red. **Example:** M6A-PR4-BNT-SS-G

Stainless Steel Directional Handles – A stainless steel handle with the same design configuration as the standard nylon handle is available for the PR4 series. Add the designator **-ST** as a suffix to the part number.

Example: 4Z-PR4-EPRT-SS-ST